

# BLACK DIAMOND®

Project Name: \_\_\_\_\_

Location: \_\_\_\_\_

Item #: \_\_\_\_\_

Qty: \_\_\_\_\_

## Black Diamond Refrigerated Chef Base, 2 Drawers, 6.5 Cu. Ft. Capacity, in Stainless Steel

### USCB-36



Increase cold storage efficiency in your commercial kitchen with the Black Diamond Refrigerated Chef Base. With a robust stainless steel exterior, fully automatic electronic controls, and a generous 6.5 Cu. Ft. capacity, this unit provides reliable refrigeration and organized drawer storage for ingredients or prepared items. Designed for durability and consistent food freshness, it includes slide-out compressor access for easy maintenance, eco-friendly R290 refrigerant, and hassle-free cleaning. Covered by a two-year parts and labor warranty plus five years on the compressor.

### FEATURES AND CONSTRUCTION

- Boasts a 6.5 Cu. Ft. capacity for ample storage needs
- Equipped with a 1/6 horsepower compressor for efficient cooling
- Constructed with durable stainless steel inside and out
- Maintains a temperature range of 33° to 40°F
- Features two solid stainless steel drawers for organized ingredient storage
- Each drawer holds one full-size pan and three 1/6 pans for flexible use
- Includes four 4-inch heavy-duty locking casters for ease of movement
- Measures 36.4"W x 32.1"D x 25.9"H
- Slide-out compressor allows easy maintenance
- Foamed-in-place polyurethane insulation enhances efficiency

### ELECTRIC

115V / 60Hz / 1Ph

Cord Length (Inches): 98.40"

Plug Type: NEMA 5-15P

Cord set included

NEMA 5-15P



### 3RD PARTY APPROVALS



### WARRANTY (USA / CANADA)

Two (2) Year Limited Warranty on Parts and Labor, Five (5) Year Warranty on Compressor and Evaporator

Contact us for details at 1.877.368.2797



### STORAGE CAPACITY

- Cubic Feet: 6.5 Cu. Ft.
- 2 Full Size Pans

### TEMPERATURE

- Holding Temperature (Fahrenheit): 33° - 40°

These models are designed to operate in an environment where temperature and humidity do not exceed 75°F (24°C) and 55% relative humidity

FRONT

SIDE

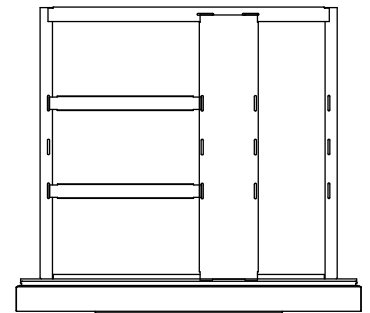
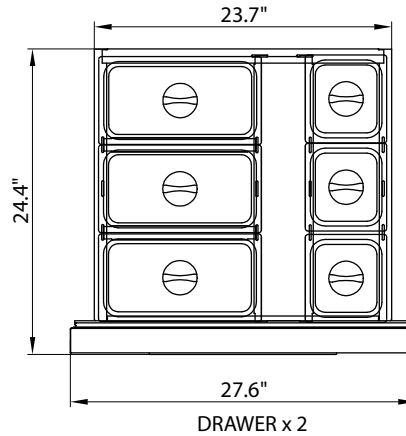
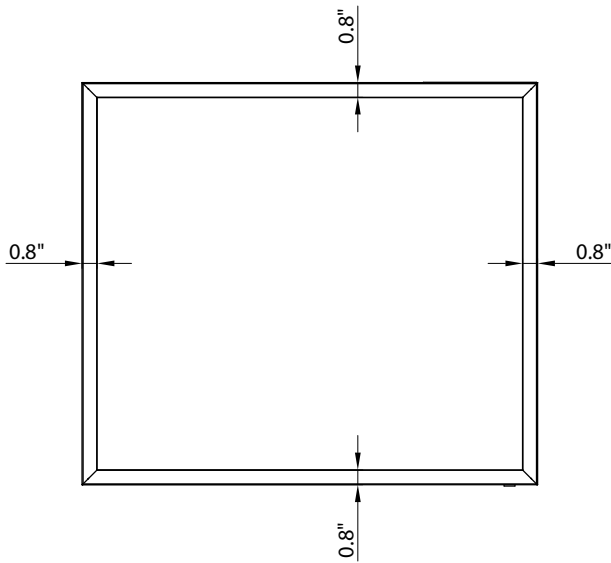
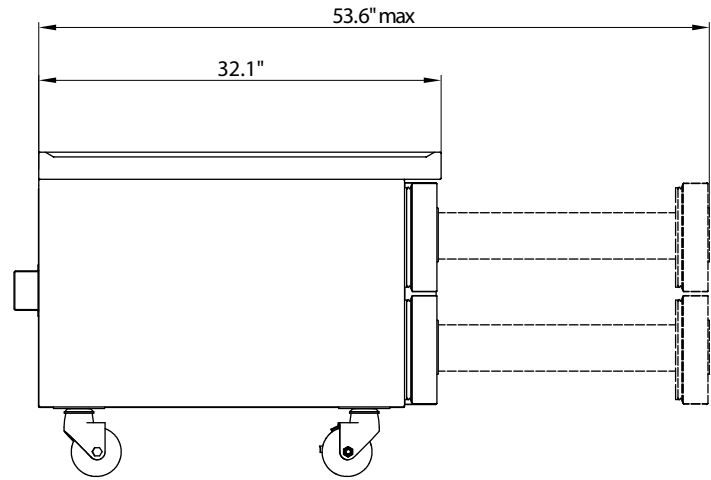
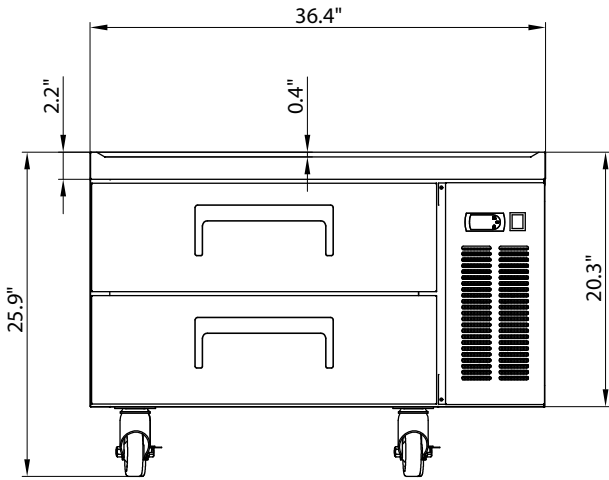

DRAWER (except GN PAN)

TOP

**Chef Base**

| Drawers | Top Weight Limit (lbs) | Amps | HP  | Refrigerant Type / Oz. | Assembled Dimensions (in) | Item Weight (lbs) | Shipping Weight (lbs) |
|---------|------------------------|------|-----|------------------------|---------------------------|-------------------|-----------------------|
| 2       | 717 lbs                | 4A   | 1/6 | R290<br>2.118 oz       | 36.40" x 32.10" x 25.90"  | 174.0             | 218.0                 |

Due to periodic changes in designs, methods, procedures, policies and regulations, the specifications contained in this document are subject to change without notice. While we exercise good faith efforts to provide information that is accurate, we are not responsible for errors or omissions in information provided or conclusions reached as a result of using the specifications. By using the information provided, the user assumes all risks in connection with such use.