

CAPSULE

*BRENTWOOD 78" SOFA
WITH USB PORTS*

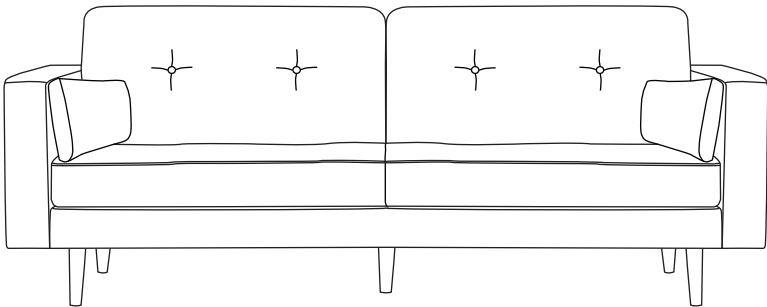

#1033

REVISED 04 DEC 2018

CAPSULEHOME.COM

BRENTWOOD 78" SOFA WITH USB PORTS

Parts and Hardware List

- To avoid possible scratching, assemble furniture on a soft surface (like a carpet or blanket).
- Be careful not to over-tighten screws.
- Questions? Find us at contact@capsulehome.com

Hardware (Actual Size)

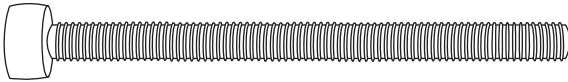

H2 x 4
Long Bolt

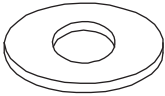

H3 x 4
Washer



H4 x 4
Lock Washer



H6 x 1
Allen Wrench

Parts

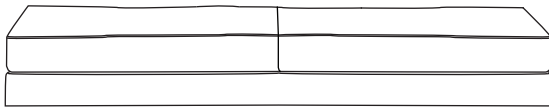
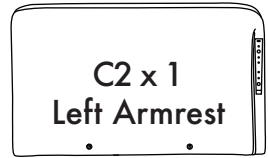
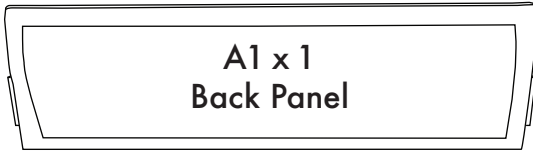

B3 x 1
Bottom Panel

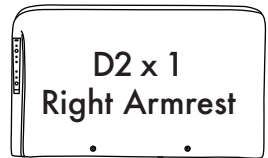

E x 5
Leg

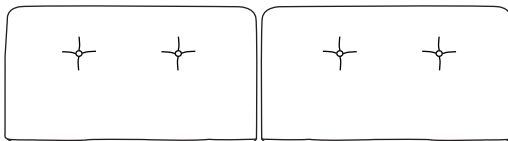

F x 2
Back
Cushion

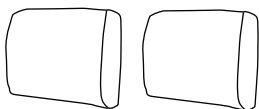

H x 2
Armrest
Cushion



I x 1
Plug-in Transformer

BRENTWOOD 78" SOFA WITH USB PORTS

Assembly Instructions

Step 1

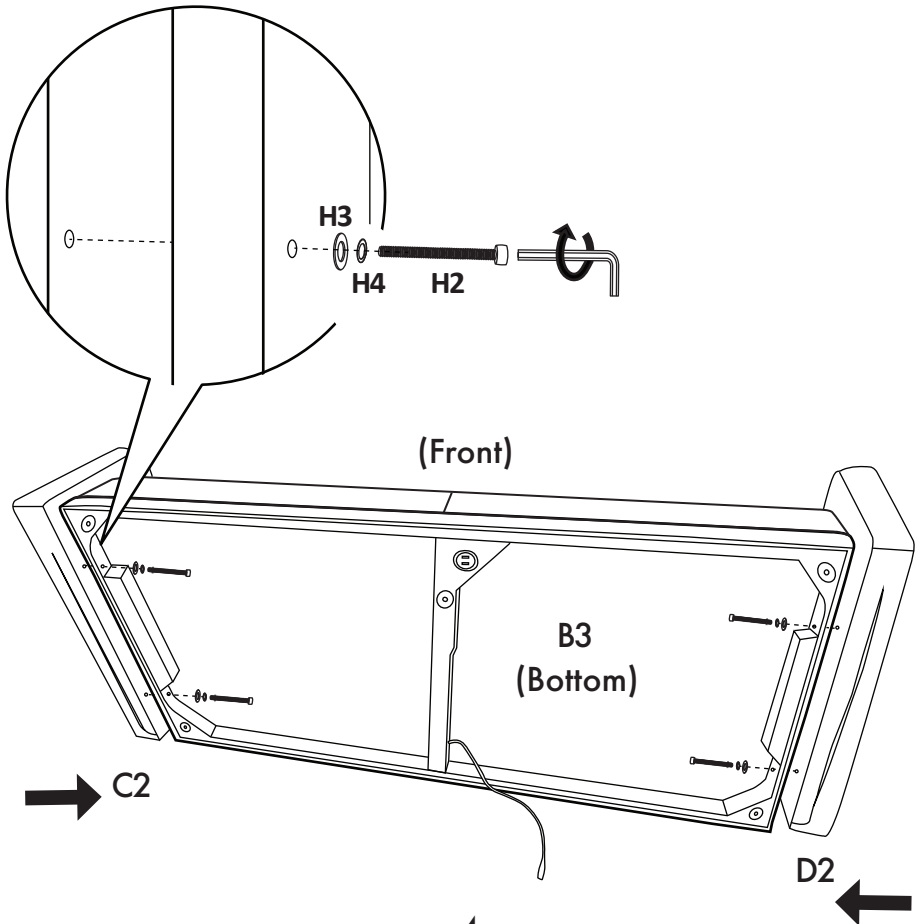
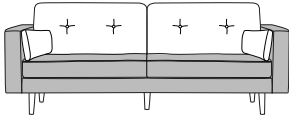

Step 2

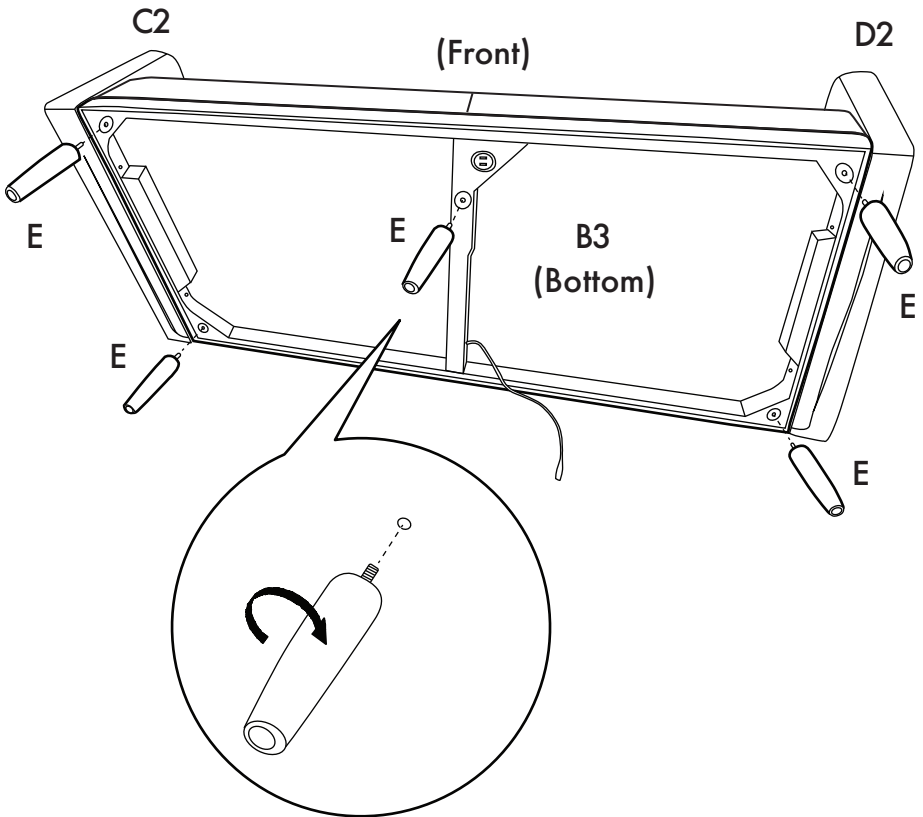
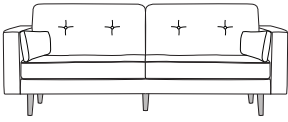

Step 3

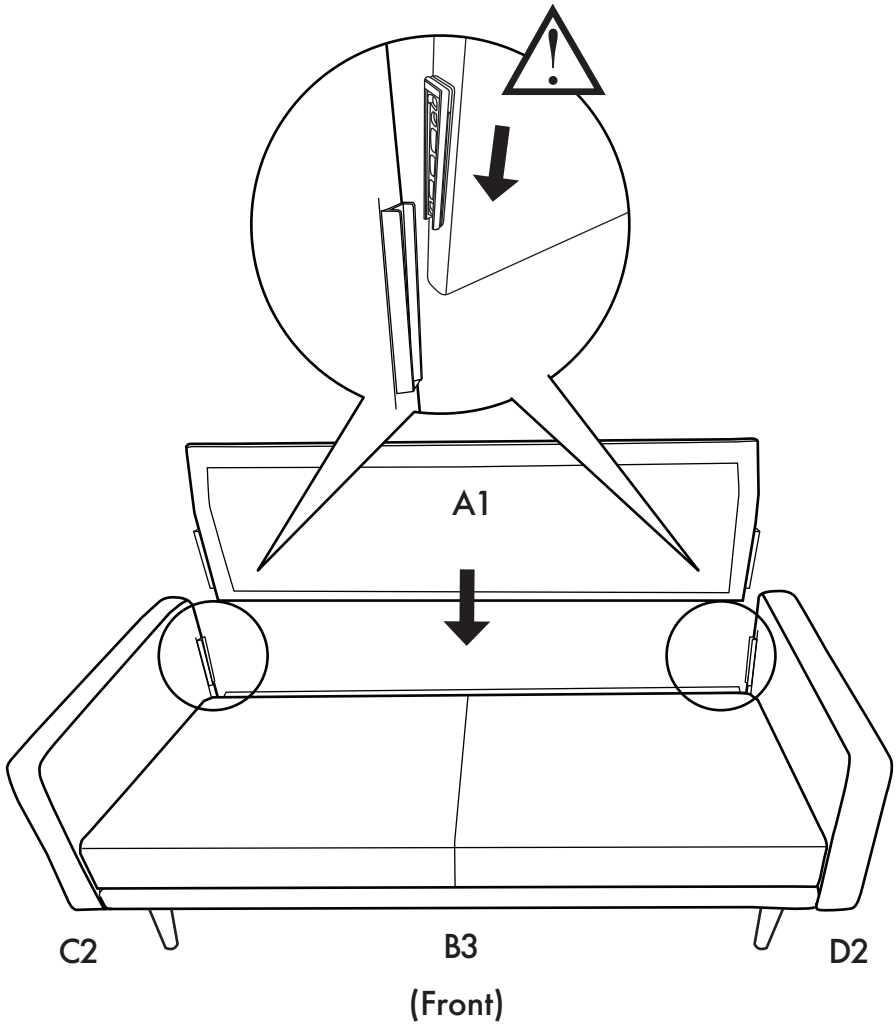
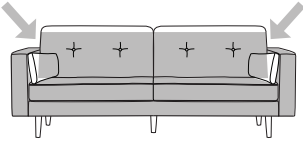

Step 4

Place the Cushions in!

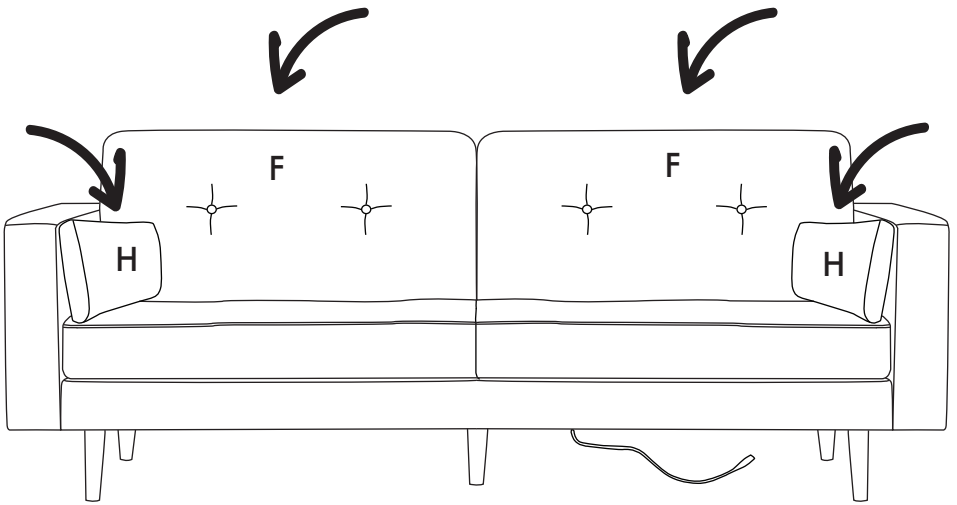

Step 5

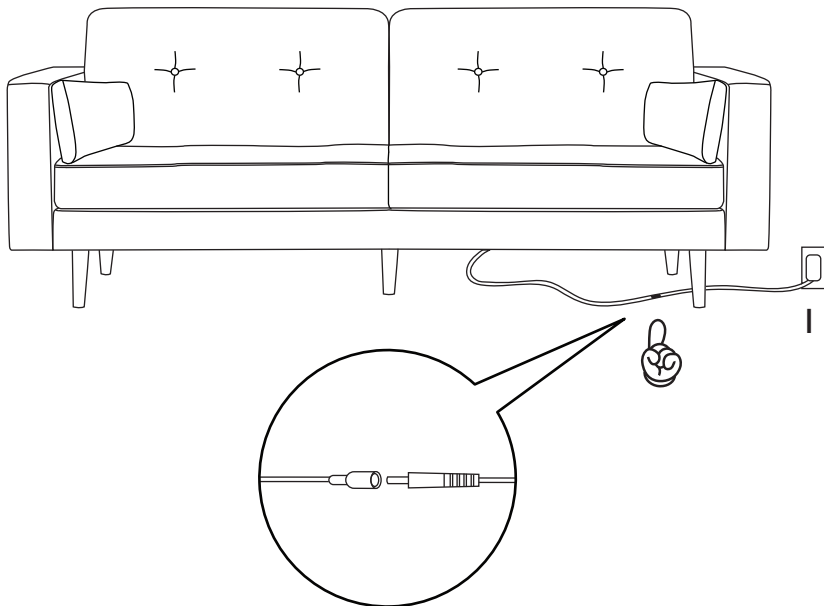

* If USB ports are not functioning after following these steps, please check the cord underneath the sofa is fully plugged in to the cord of the plug-in transformer (I).

POWER CORD SAFETY

WARNING:

UNPLUG AND REMOVE POWER CORD FROM THE WALL AND THE POWER SOCKET AT THE REAR OF THE POWERED SOFA WHEN NOT IN USE AND STORE THE CORD OUT OF REACH OF CHILDREN.

DANGER:

To reduce the risk of electric shock:
Always unplug the powered sofa from the electrical outlet before cleaning.

Step 6

Assembly is complete!



USB ports Here!

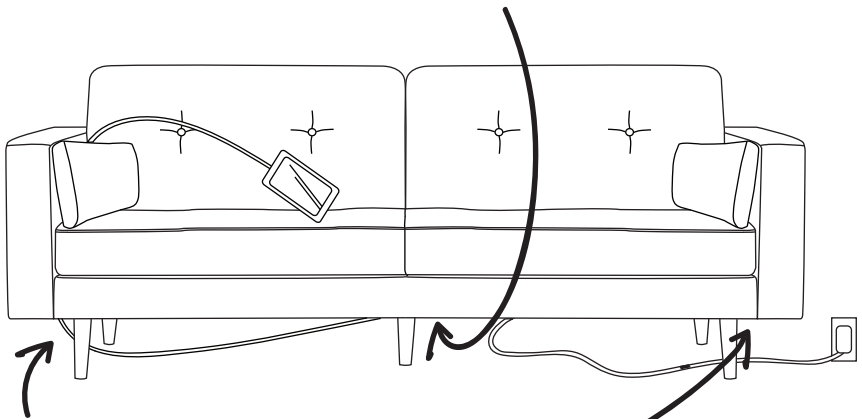

*2 Holes to String
your USB Cord!*

BRENTWOOD 78" SOFA WITH USB PORTS

- Please note that changes or modifications not expressly approved by the party responsible for compliance could void the user's authority to operate the equipment.

- NOTE: This equipment has been tested and found to comply with the limits for a Class B digital device, pursuant to Part 15 of the FCC Rules. These limits are designed to provide reasonable protection against harmful interference in a residential installation. This equipment generates, uses and can radiate radio frequency energy and, if not installed and used in accordance with the instructions, may cause harmful interference to radio communications. However, there is no guarantee that interference will not occur in a particular installation. If this equipment does cause harmful interference to radio or television reception, which can be determined by turning the equipment off and on, the user is encouraged to try to correct the interference by one or more of the following measures: --Reorient or relocate the receiving antenna. --Increase the separation between the equipment and receiver. -- Connect the equipment into an outlet on a circuit different from that to which the receiver is connected. --Consult the dealer or an experienced radio/TV technician for help.

CAUTION :

Risk of electric shock.

Dry location use only.

This Class B digital apparatus complies with Canadian ICES-003.

This Device Complies with part 15 of the FCC rules.

WARNING :

Operation is subject to the following conditions:

- 1) This device may not cause harmful interference, and
- 2) This device must accept any interference received, including interference that may cause undesired operation.

ONE YEAR LIMITED WARRANTY

Capsule Home products are warranted against defects in material and workmanship while owned by the "Original Purchaser". The term "Original Purchaser" is defined as that party or entity which purchases Capsule Home furniture from an authorized retailer as shown by the original sales receipt. This warranty does not apply to "as is" or previously owned seating products.

Capsule Home warrants its products to be free from defects in materials and workmanship (normal wear and tear, fading and stretching excepted), for one year from the date of purchase, except as provided below under the limited warranty.

The exceptions or exclusions to this warranty are as follows:

1. Any warranty claim that is submitted after the limited warranty period, or without proper proof of purchase will not include the cost of parts, labor, or delivery.
2. This warranty shall not apply to the Capsule Home products which have been subjected to misuse, neglect, alteration, modification, or attachments, either caused by the original purchaser, shipping, storage, accident, fire, flood, or acts of God.

In the event of a defect in material or workmanship covered by this warranty, Capsule Home will repair or replace, at their discretion, without charge the warranted furniture within a reasonable amount of time. We reserve the right to require damaged parts to be returned to us upon request. Natural markings such as scars, brands, grain variations, wrinkles, color variations, etc. will be considered normal characteristics and not construed as defects. We cannot warrant leather against scratching or scuffing, as all leather is subject to blemishes with use.

For claims or questions concerning this warranty, please contact Capsule Home on the web at www.capsulehome.com. Be prepared to provide your name, address, daytime phone number, the model and purchase order number of the product, date of purchase, and the store where it was purchased. Capsule Home requires that the original sales receipt be submitted with all requests to confirm that you are the original purchaser according to our written warranty.

This warranty gives you specific rights, and you may also have other rights, which vary from state to state.

All warranties are limited to the original purchaser for normal use by a maximum weight capacity is 500 pounds. Should you prefer to speak with a service representative, you may call toll free: 1-855-367-8656.

CAPSULE