

# BLACK DIAMOND®

Project Name: \_\_\_\_\_

Location: \_\_\_\_\_

Item #: \_\_\_\_\_

Qty: \_\_\_\_\_

## Black Diamond 60 Qt Planetary Mixer, 220V, 3 HP, Direct Drive, in Stainless Steel

### BDPM-60



The Black Diamond 60 Quart Planetary Mixer is an essential tool for commercial kitchens, bakeries, restaurants, and cafes. Use for blending batters, whipping cream, making mashed potatoes, preparing dough, and mixing large batches of sauces. Heavy-duty construction withstands the rigors of busy commercial environments. Features a stainless steel wire safety guard and secure bowl clamps on the 60-quart bowl.

### FEATURES AND CONSTRUCTION

- Heavy-duty construction withstands demands of commercial kitchen
- 60 qt stainless steel mixing bowl with wire safety guard
- Stainless steel bowl clamps secure mixing bowl in place
- Floor model with rubber inserts on feet for stability
- Direct drive, 100% gear-driven transmission for consistent mixing speed
- Three fixed mixing speeds; easy shift
- Push-button on/off switch
- Manual 60-minute timer
- Includes wire whisk, dough hook, and flat beater attachments
- #12 attachment hub for meat grinding attachments

### ELECTRIC

220V / 60Hz / 3 ph

### 3RD PARTY APPROVALS



### WARRANTY (USA / CANADA)

Protected by Admiral Craft Equipment Corporation's one-year limited warranty.

Contact Admiral Craft Equipment for details at 1-877-672-7740



### CAPACITY

- 60 qt

### INCLUDED COMPONENTS

- Hook, Flat Beater, Wire Whip

BDPM-60

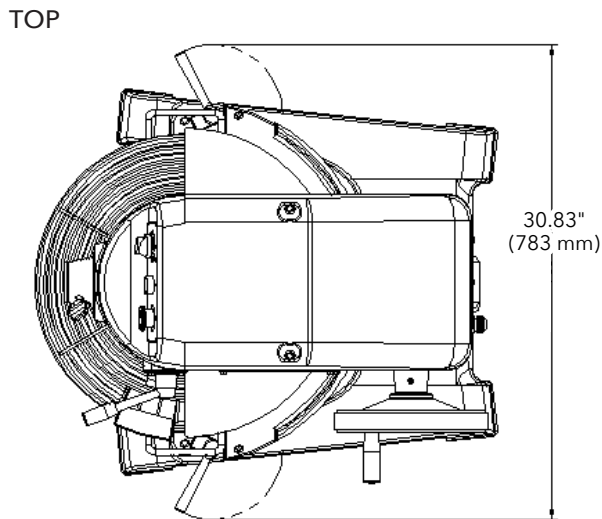
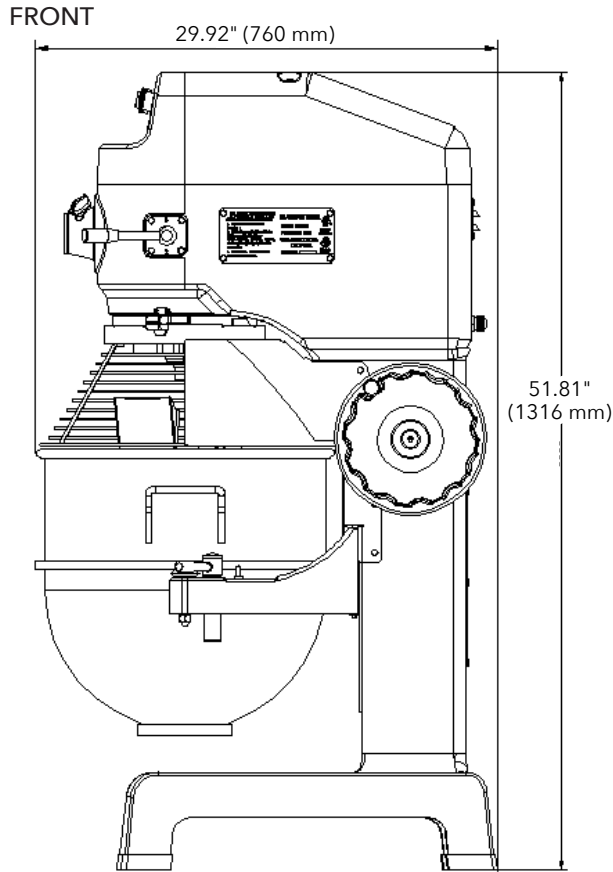

### MIXER CAPACITY CHART

Product	Agitator	Speed	Max Bowl Capacity
Bread and roll dough - 60% AR *◇	Dough hook	1st only	80 lbs
Heavy bread dough - 55% AR *•◇	Dough hook	1st only	70 lbs
Pasta Basic Egg Noodle	Dough hook	1st only	40 lbs
Pizza dough, thin - 40% AR *x•◇@	Dough hook	1st only	40lbs
Pizza dough, medium - 50% AR *•◇@	Dough hook	1st only	70 lbs (1st) / 35lbs (2nd)
Pizza dough, thick - 60% AR *•◇	Dough hook	1st only	70 lbs
Raised donut dough - 65% AR *◇	Dough hook	1st and 2nd	60 lbs
Mashed potatoes	Flat beater	2nd	40 lbs
Waffle or Hotcake batter	Flat beater	2nd	24 qts
Egg whites	Wire whip	3rd	2 qts
Meringue (Qty. of water)	Wire whip	3rd	1 3/4 qts
Whipped cream	Wire whip	3rd	12 qts
Fondant Icing	Flat Beater	2nd	36 lbs
Cake	Flat beater	2nd	60 lbs
Pie Dough	Flat beater	2nd	50 lbs

\*NOTE: The mixer capacity depends on the moisture content of the dough. When mixing doughs (pizza, bread, or bagels) remember to check your AR%!  
 %AR (% Absorption Ratio) = Water weight divided by flour weight. The capacities listed in the chart above are based on flour at room temperature and 70°F water temperature.

X Maximum Mixing Time - 7 minutes

• If high gluten flour is used, reduce the batch size by 10%

◇ If using chilled flour, water below 70°F, or ice, reduce batch size by 10%

@ 2nd speed should never be used on 60% AR or lower with the exception of the BDPM-60. BDPM-60 requires a 50% reduction in batch size to mix in speed 2 with 50% AR doughs.

Helpful measurements for calculating the correct size mixer for your application 8.3 lbs = 1 gallon of water - 2.08 lbs = 1 Quart

NOTES: Do not use attachments on the #12 hub while mixing

### Planetary

Speeds	RPMs	Capacity	Amps	HP	Wattage	Assembled Dimensions (in)	Item Weight (lbs)	Shipping Weight (lbs)
3	72/127/262	60 qt / 56.78 L	8.5	3	2200W	29.90" x 30.80" x 51.80"	661.0	756.0

Due to periodic changes in designs, methods, procedures, policies and regulations, the specifications contained in this document are subject to change without notice. While we exercise good faith efforts to provide information that is accurate, we are not responsible for errors or omissions in information provided or conclusions reached as a result of using the specifications. By using the information provided, the user assumes all risks in connection with such use.