

GLASS THREAD DETAIL
SCALE 10 : 1

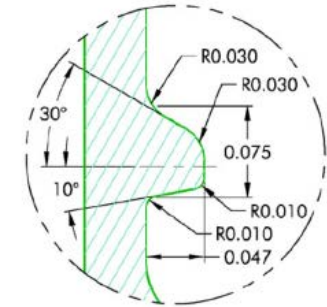

PLASTIC THREAD DETAIL
SCALE 10 : 1

MATERIAL	TOLERANCE
PP / PE	± 0.012
PET	± 0.006
GLASS	$+0.017 / - 0.018$

NOTES: (UNLESS OTHERWISE SPECIFIED)
 1. ALL DIMENSIONS ARE IN INCHES.
 2. TOLERANCE ON ALL DIMENSIONS IS ± 0.010 INCHES.
 3. CONTINUOUS RUN OF THREAD FROM LINER-WELL TO WITHIN 0.005" FROM BOTTOM OF SKIRT.

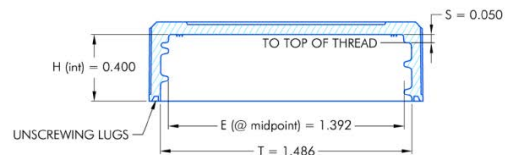
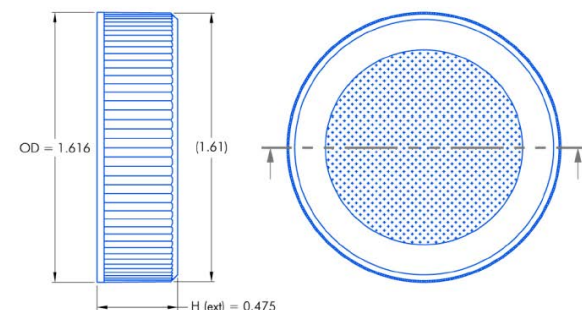

NOTES: (UNLESS OTHERWISE SPECIFIED)
 1. ALL DIMENSIONS ARE IN INCHES.
 2. TOLERANCE ON ALL DIMENSIONS GIVEN BY CHART.

DISCLAIMER	DISTRIBUTED BY:	REF NO.:
	DESCRIPTION:	
THIS INFORMATION IS PROVIDED AS A GENERAL GUIDE, INCLUDING DIMENSIONS. IT IS THE CUSTOMER'S RESPONSIBILITIES TO SELECT THE PROPER CONTAINER FOR PRODUCT AND APPLICATION COMPATIBILITY.		