



Medio & Form Series

Passage and Privacy

INSTALLATION INSTRUCTIONS

Featuring QuickFix™

Box contents

- Rose & lever set - contains 2 factory fitted screws
- Strike
- Latch
- Pack of 6 fixing screws (includes 2 anti-rotational screws)
- Jig template

Door thickness

- Passage set 32mm – 50mm
- Privacy set 32mm – 42mm

Tools required

- Tape measure
- Pencil
- Level
- Drill
- Drill bits - 4mm & 8mm
- Spade bit - 25mm
- Hammer
- Chisel
- Screwdriver (Phillips)



Scan here for more information on installing Schlage Medio and Form Series with QuickFix™



1. DOOR PREPARATION

Measure 970mm from floor, on door and jamb.

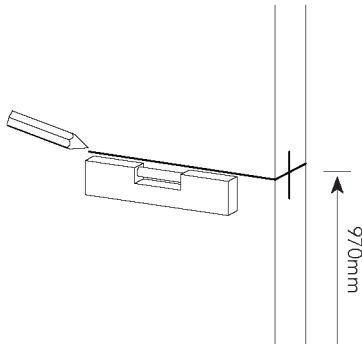

2. DRILL SPINDLE HOLE

Using the jig, mark and drill $\varnothing 25$ mm spindle hole on both sides of the door.

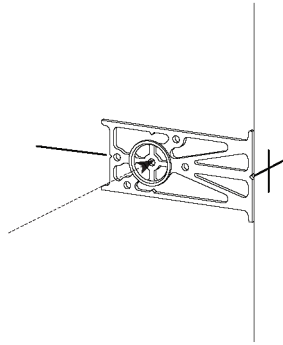

5. PREPARE JAMB & INSTALL STRIKE

Measure $\varnothing 8$ mm either side of centre mark, drill $\varnothing 25 \times 15$ mm hole. Use strike as a guide to mark and chisel recess, allowing space behind strike plate for the dust box. Insert dust box, drill holes and screw strike in place.

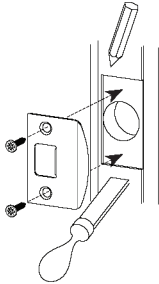

6. INSTALL FURNITURE

Attach QuickFix™ furniture with preinstalled studs and screws.

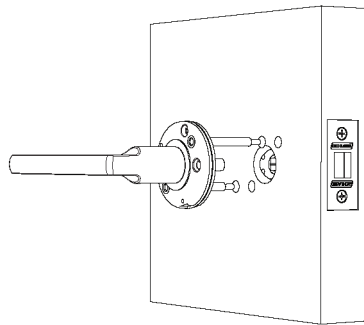

9. TIGHTEN SCREWS

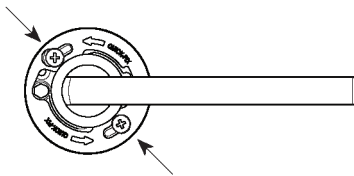

10. FIT ANTI-ROTATIONAL SCREWS

Recommend Anti-Rotation screws for all applications (Form Series Only)

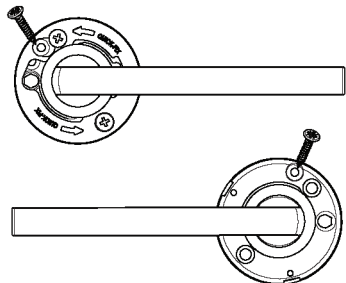

3. DRILL HOLES

Position jig within the drilled spindle hole. Mark 2x holes (labelled QF) and optional privacy (labelled PR). Drill pilot holes $\varnothing 4\text{mm}$ from both sides of the door. Re-drill $\varnothing 8\text{mm}$ holes on both sides of the door. Drill barrel hole $\varnothing 25 \times 85\text{mm}$.

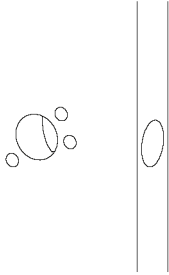

4. PREPARE & INSTALL LATCH

Use latch as guide to mark and chisel latch recess. Install latch to ensure the curved latch bolt faces the door jamb. Drill pilot holes and screw in latch.

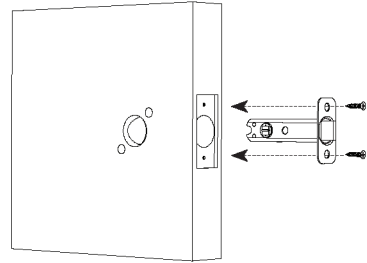

7. INSTALL FURNITURE

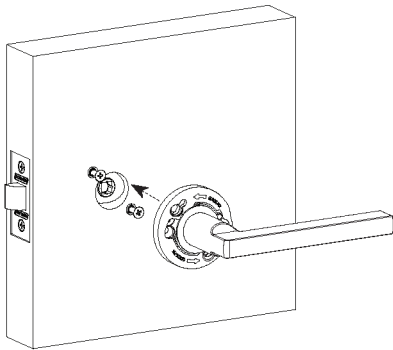

8. ROTATE BEZEL

Rotate bezel to lock in place.

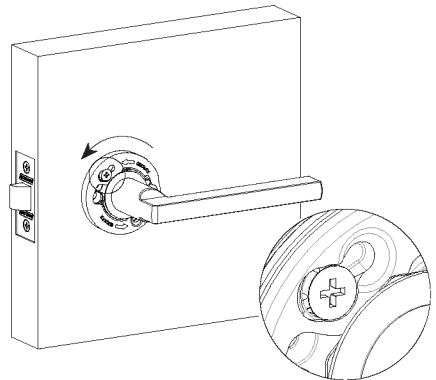

11. FIT ROSE COVER

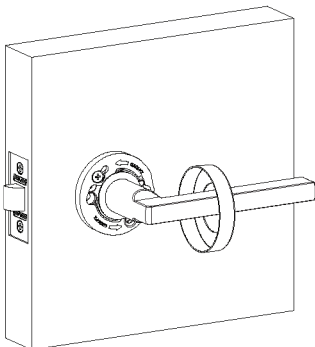

12. FIT PRIVACY PIN

PRIVACY ONLY

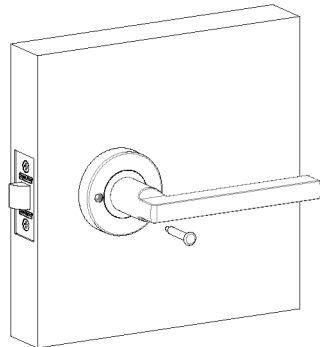

CARE AND MAINTENANCE

Door Furniture

At twelve (12) monthly intervals, the fixing screws securing the furniture to the door, both surface fix and through fix, should be checked and tightened as required. Loose fitting furniture which fails will not be covered under warranty.

All door furniture should only be wiped clean with a soft damp cloth. In the case of Satin Stainless Steel or Satin Chrome Plate, a non-abrasive mild household detergent may be used to remove ingrained grime.

Locks & Latches

Care should be taken to ensure the internal components are kept free of dirt and woodchips during installation as this is the most common cause of malfunction and will not be covered under warranty. Tubular latches used in external situations should be lubricated by an aerosol lubricant at twelve (12) monthly intervals.

Note

For applications that are subject to high use/ abuse or in corrosive environments, additional preventative maintenance will be required at a minimum of three (3) monthly intervals.

WARRANTY

Our goods come with guarantees that cannot be excluded under the local consumer law. You are entitled to a replacement or refund for a major failure and for compensation for any other reasonably foreseeable loss or damage. You are also entitled to have the goods repaired or replaced if the goods fail to be of acceptable quality and the failure does not amount to a major failure.

10 year mechanical warranty.

For finish warranty, please refer to our website www.allegion.co.nz/finisheswarranty

Allegion (Australia) Pty Ltd
Freephone 1800 098 094
Email info.au@allegion.com
www.allegion.com.au

Allegion (New Zealand) Limited
Freephone 0800 477 869
Email nzinfo@allegion.com
www.allegion.co.nz

