

5.0 Gallon Straight Sided "Grease" Pail

*Note: Available with UN-Solids Y25/S rating for Packaging Group II and III (USA & Canada)

Multiple Uses

Grease Products
Silicon Products
Dry Products

Product Codes

Container: 7502, 5500 Series, 5556
Description: 5.0 gallon 90 mil "Grease" Pail

Features

Gauge: 90 mil.
Nominal capacity: 5.0 USG / 19.0 L
Tare weights: Body: 2.01 lbs. / .911 kgs

Specifications with Cover

Dimensions: 12-3/8" D X 13-9/16"H
Maximum capacity: 5.36 USG / 21.2 L
Tare weight: 2.62 lbs. / 1.19 kgs.

Colors

Standard: White, Black and Natural
Custom: Available at manufacturer's discretion

Decorating Options

Four color offset printing
Print area: 33"W x 8-1/2"H
Sleeve or pressure sensitive labeling

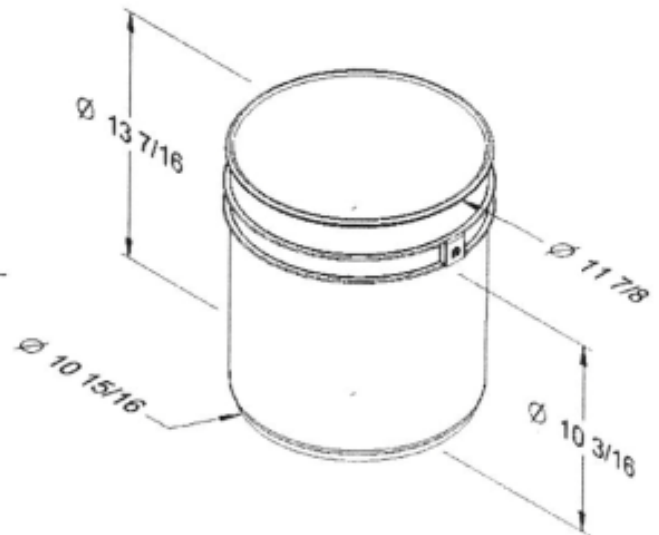

Shipping Data

Qty. per pallet/carton: 36*
Gross Weight (lbs./kgs.)**: 94 / 43
Length (in./cm.): 48 / 122
Width (in./cm.): 36 / 91.4
Height (in./cm.): 13.5 / 47

Packages

Filled Containers

36 (36 per layer / 1 layers high)
Pallet Height: 18.5"

Estimated truckload quantity of 1,008 bodies and covers***

Notes: *Quantity can vary based on customer request
**Weight does not include pallet/packaging
***Truckload quantity based on 53' trailer

Materials

FDA approved materials
Resin: Body: High-Density Polyethylene (HDPE)

Optional Carrying Handle

Wire or Plastic

DISTRIBUTED BY:



REF NO.:

DWG30158

DESCRIPTION:

5 Gallon HDPE Straight Side "Grease" Pail HDPE

DISCLAIMER

THIS INFORMATION IS PROVIDED AS A GENERAL GUIDE, INCLUDING DIMENSIONS. IT IS THE CUSTOMER'S RESPONSIBILITIES TO SELECT THE PROPER CONTAINER FOR PRODUCT AND APPLICATION COMPATIBILITY.