

Prevail

LED area, site and roadway luminaire

LUMARK



EATON

Powering Business Worldwide

Innovation you can rely on™



Prevailing innovation. Remarkable savings.

Architectural design delivers on value

The Lumark Prevail™ LED area/site luminaire combines impressive aesthetics, ease of installation features and state-of-the-art optical control resulting in significant installation and energy savings. Incorporating industry-leading, patented optics, the Prevail LED luminaire offers a choice of four precision engineered optical distributions that deliver superior control and maximize light levels, whether the application is a parking lot or a pedestrian walkway.

Innovation beyond the fixture

Prevail's innovative, versatile mounting arm gets you install ready out of the box. The patent pending, standard arm was engineered to make installation simple, saving on installation costs and time. With the ability to accommodate multiple drilling patterns as well as square and round poles, the standard versatile mounting arm is the choice for both retrofit and new applications.

Advanced design delivers savings

With a single housing that accommodates multiple lumen packages, the Prevail LED area/site luminaire provides greater than 62 percent in energy and maintenance savings over traditional HID systems, resulting in significant energy rebates. To further enhance energy savings, the Prevail luminaire takes control of code compliance, by offering customizable integrated control systems that meet even the strictest code requirements.

Engineered for long term reliability

The Prevail luminaire delivers an innovative thermal management design that maximizes heat dissipation resulting in longer fixture and LED life. Along with lumen maintenance greater than 90 percent at 60,000 hours, the rugged, die-cast fixture housing is 3G vibration and IP66 rated, which provides years of reliable operation with minimal service requirements. Backed by a five-year limited warranty, the Prevail LED area/site luminaire is the LED answer to your area and site lighting needs.



Area/site



Pathway



Wall mount

Value engineered design

The Prevail LED luminaire delivers exceptional performance in a scalable, low-profile design. The precision engineered optics provide uniform illumination to walkways, parking lots, roadways, building areas and security lighting applications. Able to replace HID fixtures ranging from 150W up to 400W, the Prevail LED luminaire is designed to meet the toughest lighting challenges.

Construction

- Rugged, single-piece, die-cast aluminum housing and driver compartment
- Hinged, tethered power door for ease of maintenance
- 3G vibration rated per ANSI C136.31
- IP66 rated optics and fixture
- UL/cUL wet location rated housing
- One-piece silicone gasket seals driver door to fixture

Electrical

- -40°C to 40°C ambient operating temperature range
- 50°C high ambient option available
- 10kV/10kA non-fused surge protection is standard
- 10kV/10kA, UL 1449 fused surge protection optional
- 120-277V 50/60Hz, 347V 60Hz or 480V 60Hz operation
- 0-10V dimming driver (standard)

Optical

- Three lumen package ranging from 6,100 - 15,100 nominal lumens
- Type II, III, IV and V distributions
- Greater than 92 percent lumen maintenance at 60,000 hours
- Delivers unparalleled uniformity and scalability
- Optional house side shield available for backlight control

Controls

- Controls-ready when equipped with ANSI 7-PIN twistlock photocontrol receptacle
- 3-PIN twistlock photocontrol receptacle available
- Optional integrated sensor for occupancy and dimming
- Optional LumaWatt wireless control and monitoring system

Mounting

- Standard versatile mounting arm accommodates multiple drilling patterns as well as square and round poles
- Easily retrofits to poles with drill patterns ranging from 1-1/2" to 4-7/8"
- Optional wall-mount arm with adapter plate is available
- Optional cast aluminum mast arm mounting adapter available

Finish

- Five-stage super TGIC paint resists extreme weather conditions while providing optimal color and gloss retention
- Available in grey, bronze (standard), black, dark platinum, graphite metallic or white

Warranty

- Five-year warranty

Optional features



Wireless control and monitoring system

Sensor capable of motion and photo sensing, metering power consumption and wireless communication.



Integrated sensor

Optional integrated sensor is capable of occupancy and dimming resulting in the reduction of energy required for area/site lighting applications.



NEMA 3-PIN photocontrol receptacle

Gasketed receptacle for mounting standard 3-PIN NEMA photocontrol.



NEMA 7-PIN photocontrol receptacle

ANSI C136.41 compliant. Enables wireless dimming when used with compatible photocontrol.

A15 (Single LED = 6,100 nominal lumens)
A25/A40 (Dual LEDs = 10,200/15,100 nominal lumens)

Integrated sensor (Optional)

Standard versatile mounting arm
 (Patent pending)

Low-profile architectural design



Mounting options



House side shield
 For stringent light trespass requirements and the ultimate level of backlight control, a house side shield accessory is available for factory or field installation.



Arm mount
 Standard versatile mounting arm is simple to install and can be used with existing poles for retrofit installations.



Wall mount
 Wall mount option utilizes an adapter plate secured to wall with four bolts for perimeter lighting applications (Bolts not included).



Mast arm mount
 An optional cast aluminum mast arm adapter secures fixture head to nominal 2" (2-3/8" O.D. pipe size) horizontal steel tenon arm for roadway applications.

Retrofit and installation has never been easier

Time is money when it comes to installing and retrofitting area and site luminaires. The Prevail luminaire's patent pending, standard versatile mounting arm was engineered to make installation quick and easy, saving on both installation time and costs. Optional wall and mast arms are also available for even more design flexibility for any building mount, street and roadway applications.

Retrofits multiple drill patterns

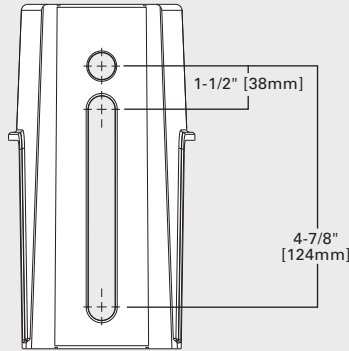

- Standard versatile arm can accommodate any existing drill pattern ranging from 1-1/2" to 4-7/8"
- Simply remove the existing luminaire and install the versatile arm to the existing top bolt location
- Align the slot to the existing 2nd bolt location and bolt into place
- Installation requires zero field drilling of the pole, saving time and money

1

Simply install the luminaire

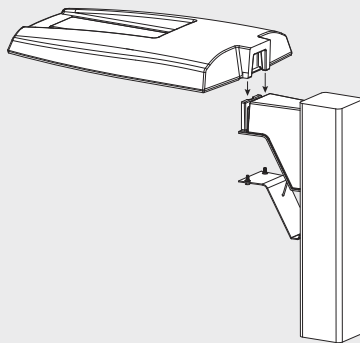

- Simply slide the Prevail luminaire onto the installed versatile arm and secure with a single screw
- The versatile mounting arm's door is tethered and includes captive fasteners to prevent accidental dropping
- The Prevail luminaire can be easily mounted and installed by a single person due to the innovative and simple versatile arm design

2

Safe and secure completion

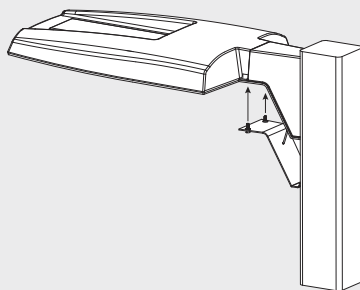

- Ample space is provided within the Prevail's arm to access and wire the luminaire
- Make the necessary wiring connections and reattach the tethered arm cover to complete installation
- There is zero need to access the driver compartment during installation, insuring a reliable, secure and safe installation

3



Universal pole mounting

The versatile mounting arm includes integrated breakaway tabs to accommodate both square or round poles. Installation does not require an additional pole adapter plate, which simplifies the ordering and installation process for both retrofit and new construction applications.

Application excellence

Uniform illumination

Easily replacing a 400W HID site fixture, the Prevail LED luminaire is the solution whether retro-fitting an existing site or lighting a new location. Four optical distributions allow the lighting designer to put light exactly where it's needed without wasting energy with extra light spilling onto unwanted locations. An optional house-side shield is available when extreme cut-off is needed at the property lines. Parking areas must be designed to provide safety and security to both pedestrians and vehicular traffic. Good exterior lighting design will deter criminals, and attract patrons all while limiting light pollution. The IESNA has provided two documents to aid in proper parking lot lighting design; RP-20 lighting for parking facilities and RP-33 lighting for exterior environments. Proper illumination levels for site and area design are achieved by maintaining an absolute minimum illuminance level at any given point within the site, while holding acceptable maximum-to-minimum uniformity levels. The Prevail LED luminaire is ideal for parking lots, small retail, security, and roadway applications.

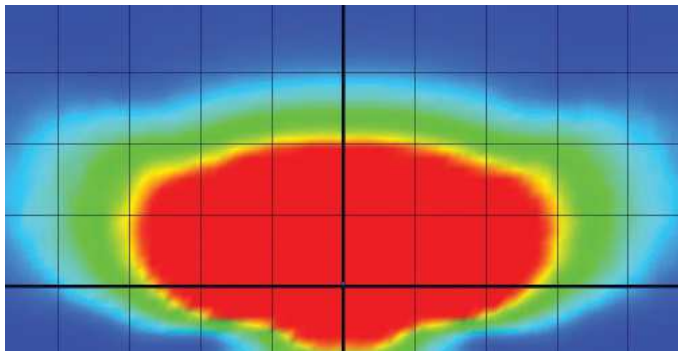

Prevail A40 LED (Type III shown)

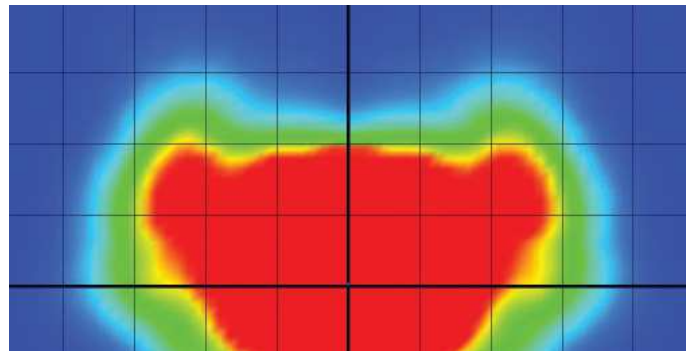

400W Pulse Start Metal Halide (Type III shown)

Greater than 68 percent in HID to LED retrofit savings

The following comparison shows the Prevail A40 luminaire and a 400W pulse start metal halide shoebox type luminaire in a typical parking lot application. All fixtures are at the same mounting height and locations. The same number of poles and fixture heads are used to calculate a one-for-one direct comparison. The Prevail luminaire not only provides a higher minimum and much more uniform layout, but it also provides more than 68 percent in energy savings over the HID solution.



Prevail A40 LED
14 Fixtures = 2,002 Total watts



400W Pulse Start Metal Halide
14 Fixtures = 6,370 Total watts

Site Lighting Comparison Numbers

Fixture / Source	Number of Fixtures	Total Site Wattage	Average (Footcandles)	Maximum (Footcandles)	Minimum (Footcandles)	Uniformity	
						Avg. / Min.	Max. / Min.
A40 Prevail LED	14	2,002	1.63	3.88	0.50	3.26	7.76
400W Pulse Start Metal Halide	14	6,370	2.02	7.84	0.03	67.33	261.33

* 25' mounting height.

Dimming and occupancy



Area/site applications

For outdoor area/site applications, lighting should be dimmed or turned off according to pedestrian traffic and safety requirements. Scheduled dimming and occupancy detection can be combined to reduce maximum lighting levels outside business hours. Upon occupancy detection, the luminaire returns to full lighting to maintain security lighting levels.

Minimize power consumption, maximize energy savings

To further enhance energy savings, lighting management and control can reduce power consumption and energy costs by providing the appropriate light levels at the right place and time when required. Lighting can be reduced during low usage hours, saving energy, then raised on demand with occupancy detection. Adding motion sensor and dimming controls capabilities also extends the life of the luminaire due to reductions in electrical load and case temperatures on the LEDs and drivers. The Prevail LED area and site luminaires control options are designed to be simple and cost-effective ASHRAE and California Title 24 compliant solutions.

On/off or bi-level motion sensor (MSP)

The Prevail LED area and site luminaires integrated dimming and occupancy sensor is a standalone control option that can automatically dim the luminaire to 50 percent with a time delay of 10 minutes if no occupancy is detected. When activity is detected, the luminaire returns to full light output. This option is available in 12' - 30' mounting heights in on/off operation or bi-level operation. To change these settings, a hand held programmable remote can be purchased that allows the dimming level, sensitivity and time delay settings to be adjusted.

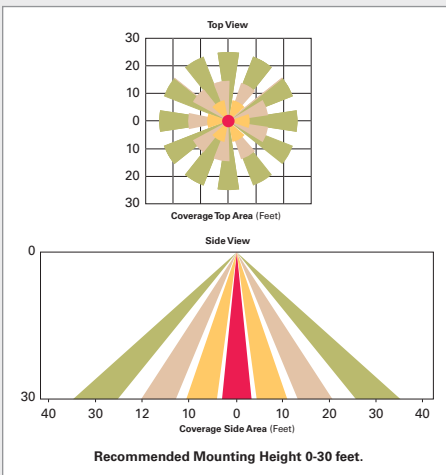

Worry-free controls planning

Ensure complete coverage and performance with an integrated sensor system built into every luminaire based on fixture mounting height. The integrated sensor is available in mounting heights from 12-30'.

Integrated design

With a single product to mount, and a single electrical connection to make, the Prevail luminaire with an integrated sensor system saves money on the total installed cost when occupancy and daylight dimming controls are needed.

Sensor remote control

When the application demands more, the sensor system has the option to make changes using a remote control. The remote allows changes from the default settings for occupied/unoccupied, target light level, and time outs.

Lighting management and control



Light level automation

A 30-50 percent reduction of energy use is not uncommon as a result of combining basic lighting control strategies. The LumaWatt system employs four control strategies to automate luminaire behavior: Scheduled ON/OFF, Scheduled Dimming, Occupancy Detection and Daylight Harvesting.

Lumawatt outdoor wireless control and monitoring system

Different environments pose different challenges when balancing power reduction against usage requirements. Lighting management and control can minimize power consumption and energy costs by providing the right light levels where and when they're needed. Standards and codes, such as, ASHRAE and Title 24, provide guidance for the automation of lighting systems but taking advantage of these can be complicated. To be effective, lighting management control systems need to be simple, flexible and reliable. The LumaWatt system offers the perfect combination of features that eliminates the need for remote sensors, reducing installation costs and commissioning time. Multi-functional sensors are factory-installed and tested in each luminaire so reliability, area coverage and location are never concerns.

The LumaWatt system is a peer-to-peer wireless network of luminaire-integrated sensors, which operate in accordance with stored programmable profiles. Each sensor is capable of motion and photo sensing, metering power consumption and wireless communication. Sensor profiles dictate how the individual luminaires operate, as well as how to function among network peers. The end user can create and manage sensor profiles with browser-based management software and transmit to sensors via wireless gateways.

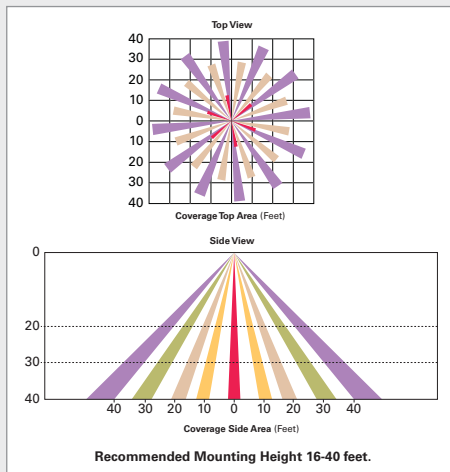

Coverage area

Designed to detect motion within its field-of-view, LumaWatt system sensors are considered line-of-sight sensors, meaning that no obstruction can exist between the sensor and the object being detected. The area of coverage depends on the mounting height determined from a chart of its detection pattern.



Sensor module

The LumaWatt system sensor is available with two passive infrared sensor geometries—wide for mounting heights of 8' to 16' and narrow for 16' to 40'. Sensors are factory installed in every luminaire for reliability, saving installation time.



Monitoring system

Management software creates and manages sensor profiles via easy-to-use, web-based software, providing summaries of power metering and system performance.

Energy savings

Reduced energy consumption

Operating and maintenance costs of a lighting system are dramatically impacted by the specified lamp source, system power consumption and the duration time of operation. Total system input watts and fixture operating life should be the driving considerations when addressing energy consumption and total cost of ownership. Energy savings increase when energy consumption is reduced and maintenance intervals are extended.

Annualized Energy Savings / Cost Comparison

Product	Hours Days / Year	Input Watts	TM-21 Data / HID Life (Hours)	Cost / Year at \$.10 kWh ¹	Annual Maintenance Cost ²	Total Energy Cost/Fixture and Maintenance	Annual Savings Per Fixture	Savings (Percent)
A40 Prevail LED Site Light	11 / 4,015	143W	60,000	\$57.41	–	\$57.41	\$186.07	76%
400W Metal Halide Site Light		458W	20,000	\$183.89	\$59.60	\$243.49		
A25 Prevail LED Site Light	11 / 4,015	87W	60,000	\$34.93	–	\$34.93	\$158.57	82%
250W Metal Halide Site Light		290W	15,000	\$116.44	\$77.07	\$193.50		
A15 Prevail LED Site Light	11 / 4,015	57W	60,000	\$22.89	–	\$22.89	\$109.20	83%
150W Metal Halide Site Light		190W	20,000	\$76.29	\$55.80	\$132.09		

NOTE: 1. Cost = (Watts x 11 Hours Per Day x 365 Days Per Year / 1000 = Daily Kilowatt hour (kWh). kWh x 0.10 cents/kWh = Cost / Year. **2.** Maintenance = number of relamps over 60,000 hours (15 years) x lamp cost and replacement labor /15 years.

Energy Savings / Equivalency / Cross Reference Guide

Prevail	HID Replacement Options	Lamp System	HID Wattage	HID Rated Average Life (Hours)	Prevail LED Wattage	Prevail TM-21 Data (Hours) *	Energy Savings (Percent)
PRV-A40	320W - 400W HID	320W Metal Halide	377W	20,000	143W	>L90 @ 60,000	62%
		350W Metal Halide	397W	20,000			64%
		400W Metal Halide	458W	20,000			69%
		400W High Pressure Sodium	464W	24,000			69%
PRV-A25	200W - 250W HID	200W Metal Halide	232W	15,000	87W	>L90 @ 60,000	63%
		200W High Pressure Sodium	240W	24,000			64%
		250W Metal Halide	290W	15,000			70%
		250W High Pressure Sodium	295W	24,000			71%
PRV-A15	100W - 175W HID	150W Metal Halide	190W	20,000	57W	>L90 @ 60,000	70%
		150W High Pressure Sodium	170W	24,000			66%
		175W Metal Halide	210W	14,000			73%

NOTE: * Lumen maintenance for LED at 40° ambient temperature. TM-21 hour data based on six times number of hours LED chip test time.

Utility incentive programs

Utility companies (power providers) are leading the way in responding to climate change and the power sector's role in reducing greenhouse gases while meeting the country's growing energy needs. Utilities offer customers incentives to install high-efficiency luminaires that reduce the demand for power in their areas. The Prevail LED luminaire qualifies for a majority of these incentive programs. There are two types of incentive programs offered. Prescriptive incentive programs provide a specific predetermined dollar amount for each fixture replaced. Custom rebates are based on the total energy savings for a specific project.

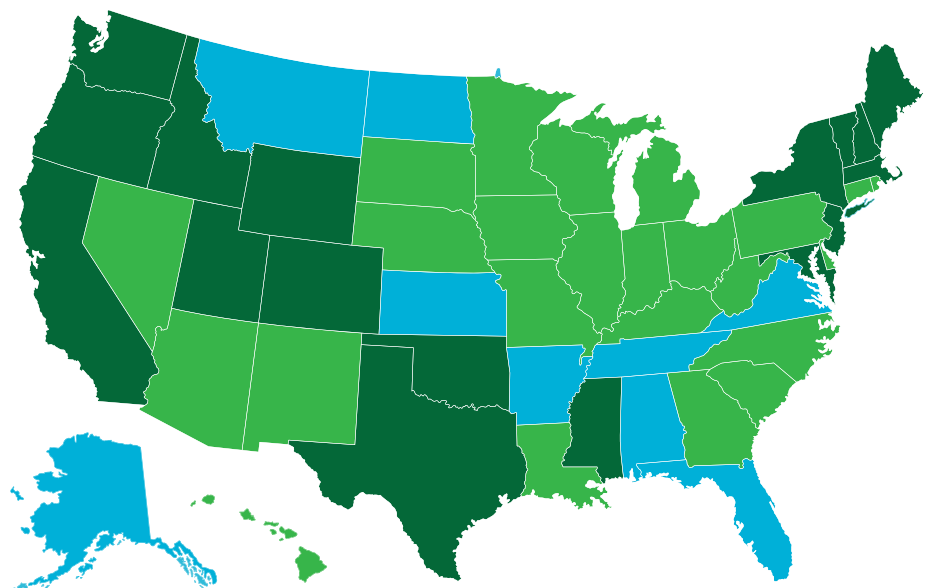

Utility Incentive Programs *

\$ Custom Incentive
 < \$150 Prescriptive Incentive
 > \$150 Prescriptive Incentive

* As of September 19, 2015.

Ordering information

Sample Number: PRV-A25-D-UNV-T3-SA-BZ

Product Family ^{1,2}	Light Engine ³	Driver ⁴	Voltage	Distribution	Mounting	Color ⁶
PRV=Prevail	A15=(1 LED) 6,100 Nominal Lumens A25=(2 LEDs) 10,200 Nominal Lumens A40=(2 LEDs) 15,100 Nominal Lumens	D=Dimming (0-10V)	UNV=Universal (120-277V) 347=347V 480=480V ⁵	T2=Type II T3=Type III T4=Type IV T5=Type V	SA=Standard Versatile Arm MA=Mast Arm WM=Wall Mount Arm	AP=Grey BZ=Bronze (Standard) BK=Black DP=Dark Platinum GM=Graphite Metallic WH=White
Options (Add as Suffix)				Accessories (Order Separately) ¹¹		
7030=70 CRI / 3000K CCT ⁷ 7050=70 CRI / 5000K CCT ⁷ 10K=10kV/10kA UL 1449 Fused Surge Protective Device DIMRF-LW=LumaWatt Wireless Sensor, Wide Lens for 8' - 16' Mounting Height ^{8,9} DIMRF-LN=LumaWatt Wireless Sensor, Narrow Lens for 16' - 40' Mounting Height ^{8,9} MSP/DIM-L12=Integrated Sensor for Dimming Operation, 8' - 12' Mounting Height MSP/DIM-L30=Integrated Sensor for Dimming Operation, 12' - 30' Mounting Height MSP-L12=Integrated Sensor for ON/OFF Operation, 8' - 12' Mounting Height MSP-L30=Integrated Sensor for ON/OFF Operation, 12' - 30' Mounting Height PER=NEMA 3-PIN Twistlock Photocontrol Receptacle ¹⁰ PER7=NEMA 7-PIN Twistlock Photocontrol Receptacle ¹⁰ HSS=House Side Shield HA=50°C High Ambient Temperature				PRVWM-XX=Wall Mount Kit PRVMA-XX=Mast Arm Mounting Kit PRVSA-XX=Standard Versatile Mounting Kit HS/VERD=House Side Shield MA1010-XX=Single Tenon Adapter for 3-1/2" O.D. Tenon MA1011-XX=2@180° Tenon Adapter for 3-1/2" O.D. Tenon MA1012-XX=3@120° Tenon Adapter for 3-1/2" O.D. Tenon MA1013-XX=4@90° Tenon Adapter for 3-1/2" O.D. Tenon MA1014-XX=2@90° Tenon Adapter for 3-1/2" O.D. Tenon MA1015-XX=2@120° Tenon Adapter for 3-1/2" O.D. Tenon MA1016-XX=3@90° Tenon Adapter for 3-1/2" O.D. Tenon MA1017-XX=Single Tenon Adapter for 2-3/8" O.D. Tenon MA1018-XX=2@180° Tenon Adapter for 2-3/8" O.D. Tenon MA1019-XX=3@120° Tenon Adapter for 2-3/8" O.D. Tenon MA1045-XX=4@90° Tenon Adapter for 2-3/8" O.D. Tenon MA1048-XX=2@90° Tenon Adapter for 2-3/8" O.D. Tenon MA1049-XX=3@90° Tenon Adapter for 2-3/8" O.D. Tenon MA1191-XX=2@120° Tenon Adapter for 2-3/8" O.D. Tenon OA/RA1013=Photocontrol Shorting Cap OA/RA1014=NEMA Photocontrol - 120V OA/RA1016=NEMA Photocontrol - Multi-Tap 105-285V OA/RA1027=NEMA Photocontrol - 480V OA/RA1201=NEMA Photocontrol - 347V ISHH-01=Integrated Sensor Programming Remote		

NOTES: 1 Customer is responsible for engineering analysis to confirm pole and fixture compatibility for all applications. Refer to installation instructions IB500002EN and pole white paper WP513001EN for additional support information. 2 DesignLights Consortium™ Qualified and classified for both DLC Standard and DLC Premium, refer to www.designlights.org for details. 3 Standard 4000K CCT and 70 CRI. 4 Consult factory for driver surge protection values. 5 Only for use with 480V Wye systems. Per NEC, not for use with ungrounded systems, impedance grounded systems or corner grounded systems (commonly known as Three Phase Three Wire Delta, Three Phase High Leg Delta and Three Phase Corner Grounded Delta systems). 6 Different housing colors impact lumen output. IES files for the non-standard colors are available upon request. 7 Extended lead times apply. Use dedicated IES files for 3000K and 5000K when performing layouts. These files are published on the Prevail luminaire product page on the website. 8 LumaWatt wireless sensors are factory installed and require network components RF-EM-1, RF-GW-1 and RF-ROUT-1 in appropriate quantities. See website for LumaWatt application information. 9 LumaWatt wireless system is not available with photocontrol receptacle (Not needed). 10 Not available with MSP or DIMRF options. 11 Replace XX with paint color.

Stock Sample Number: PRVS-A25-UNV-T3

Product Family	Light Engine	Voltage	Distribution	Options (Add as Suffix)
PRVS=Prevail Stock	A15=(1 LED) 6,100 Nominal Lumens A25=(2 LEDs) 10,200 Nominal Lumens A40=(2 LEDs) 15,100 Nominal Lumens	UNV=Universal (120-277V) 347=347V	T3=Type III T4=Type IV	MSP/DIM-L30=Integrated Sensor for Dimming Operation, Maximum 30' Mounting Height

NOTE: Bronze only, 4000K CCT, 120-277V, 347V, standard mounting arm, standard non-fused 10kV MOV and 0-10V dimming.

Dimensions

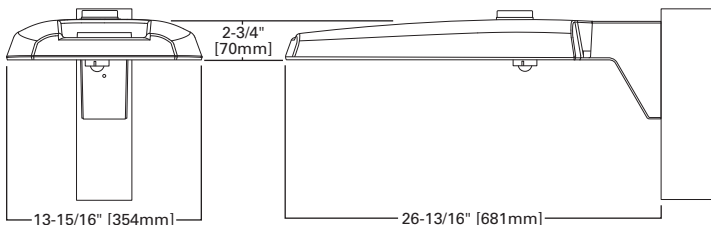

Additional Information

Compliances	Technical Data (Electronic Driver)
UL and cUL Wet Location Listed IP66-Rated Optics and Fixture 3G Vibration Rated per ANSI C136.31 ISO 9001 DesignLights Consortium™ Qualified ¹	+40°C (104°F) Ambient Temperature Rating -40°C (-40°F) Ambient Temperature Rating >0.9 Power Factor <20% Total Harmonic Distortion 120-277V 50/60Hz 347V 60Hz, 480V 60Hz ²
EPA (Effective Projected Area - Square Feet)	Shipping Data (Approximate Net Weight)
0.75	20 lbs. (9.09 kgs.)

NOTES: 1 DesignLights Consortium™ Qualified and classified for both DLC Standard and DLC Premium, refer to www.designlights.org for details. 2 480V is compatible for use with 480V Wye systems only.

Versatile Pole Mount Arm

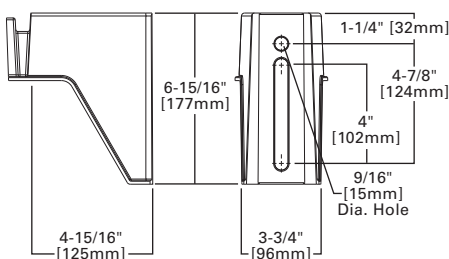

Wall Mount Arm

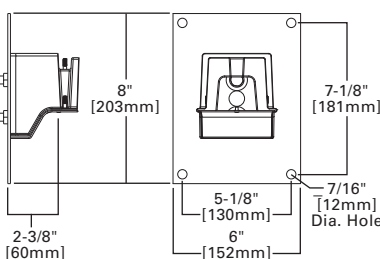

Mast Arm Mount

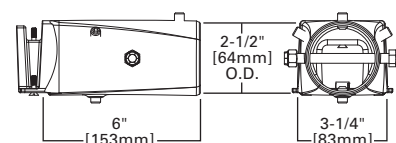

IP66 Rated



NOTE: Specifications and dimensions subject to change without notice.

**Our Lighting
Product Lines**

Halo
Halo Commercial
Portfolio
Iris
RSA
Metalux
Corelite
Neo-Ray
Fail-Safe
MWS
Ametrix
Shaper
io
Lumark
McGraw-Edison
Invue
Lumière
Streetworks
AtLite
Sure-Lites

**Our Controls
Product Lines**

Greengate
iLumin
Zero 88
Fifth Light Technology
iLight (International Only)

Eaton

1121 Highway 74 South
Peachtree City, GA 30269
P: 770-486-4800
www.eaton.com/lighting

Canada Sales

5925 McLaughlin Road
Mississauga, Ontario L5R 1B8
P: 905-501-3000
F: 905-501-3172

© 2015 Eaton
All Rights Reserved
Printed in USA
Publication No. BR500006EN
December 2015

Eaton is a registered trademark.

All other trademarks are property
of their respective owners.

Product availability, specifications,
and compliances are subject to
change without notice.



Powering Business Worldwide