

# 10.0 Liter Standalone Tight Head

## Product Uses

Liquid Products

## Product Codes

Container: Standalone Tighthead

## Features

UN Rating: 3H1/Y1.8/100  
Nominal capacity: 2.64 USG / 10.0L  
Maximum capacity: 2.8 USG / 10.6 L  
Tare weights: 1.58 lbs / .72 kgs

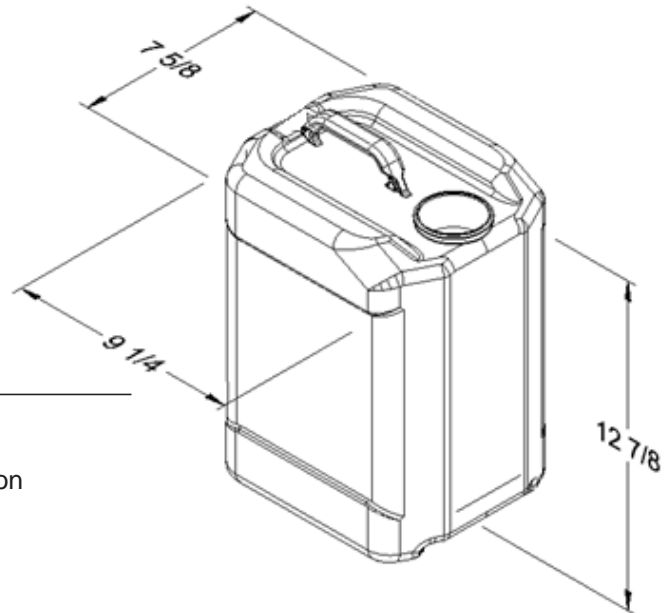

## Colors

Standard: White, Black, Blue and Natural  
Custom: Available at manufacturer's discretion

## Decorating Options

See Salesperson for Options

## Shipping Data

Qty. per floor spot:	200
Gross Weight (lbs./kgs)*:	285 / 129
Length (in./cm.):	45.75 / 116
Width (in./cm.):	38.125 / 97
Height (in./cm.):	107 / 272

## Containers

Estimated truckload quantity of 6,000 containers\*\*

Notes: \*Weight does not include pallet / packaging  
\*\*Truckload quantity based on 53' trailer

## Materials

FDA approved materials

Resin: Body: High-Density Polyethylene (HDPE)

## Optional Carrying Handle

Integral

DISTRIBUTED BY:



REF NO.:

DWG20407

DESCRIPTION:

10 liter HDPE Square Tight Head, 70 mm, UN Rated

## DISCLAIMER

THIS INFORMATION IS PROVIDED AS A GENERAL GUIDE, INCLUDING DIMENSIONS. IT IS THE CUSTOMER'S RESPONSIBILITIES TO SELECT THE PROPER CONTAINER FOR PRODUCT AND APPLICATION COMPATIBILITY.