

Top Spud Urinal Installation Instructions

▲ WARNING: Any vitreous china can chip or break if the bolts or nuts are over-tightened or if mishandled. Personal injury can occur if product is mishandled.

BEFORE YOU START...

- Observe all local plumbing and building codes.
- Check for any damage to the new urinal before installation.
- Make sure the wall is strong enough to support the new urinal prior to installation. Reinforce or install a urinal carrier if necessary.
- Urinal complies to ASME Standard A112.19.2

WHAT YOU WILL NEED...

- Electric Drill (heavy duty 1/2" VSR hammer drill preferred if mounting to concrete wall)
- High Speed or carbide tipped masonry bits if mounting to concrete wall
- Putty knife or sharp scraper
- Screwdrivers (Phillips and flat head)
- Safety glasses
- Measuring tape and marker
- Level (24" minimum preferred)
- Caulking gun and caulk
- Channel lock pliers, adjustable wrench, and utility knife
- Manual or electric drain cleaner
- Additional materials and tools may be required for rough-in and reinforcing.

NOTE: Plumbing System Requirements
√ Minimum **Flowing** Pressure: 25 PSI

▲ WARNING: Hazardous gases can escape through the waste pipe if new urinal is not installed quickly. A temporary fix: place a rag in the waste pipe hole.

RETROFIT INSTALLATIONS

1. REMOVE EXISTING URINAL

- Turn off the water supply.
- Disconnect the flush valve.
- Cut caulk all around existing urinal using utility knife to release urinal from wall surface.
- Remove any attaching bolts that may be holding the urinal at the bottom.
- Remove urinal from wall.
- Remove existing hanger bracket.
- Using sharp scraper or putty knife, completely remove all remaining caulk from wall.
- Remove existing outlet flange and gasket and discard.

2. CHECK ROUGH-IN DIMENSIONS

- Check rough-in dimensions. Make any adjustments to water supply to accommodate flush valve as necessary.

3. CLEAN DRAIN

- Clean out waste pipe using hand or power cleaner to be sure pipe is clear.
- Proceed to NEW INSTALLATIONS.

NEW INSTALLATIONS

1. INSTALL OUTLET FLANGE AND GASKET

- Remove the temporary rag (if used) from the waste pipe hole.
- Apply thread sealant to waste pipe threads and install new outlet flange on pipe.

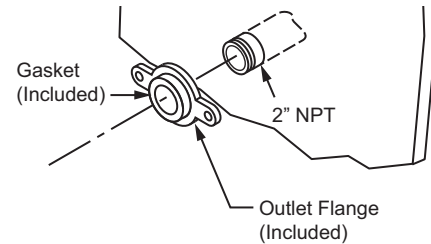

2. INSTALL NEW WALL HANGER BRACKET (INCLUDED)

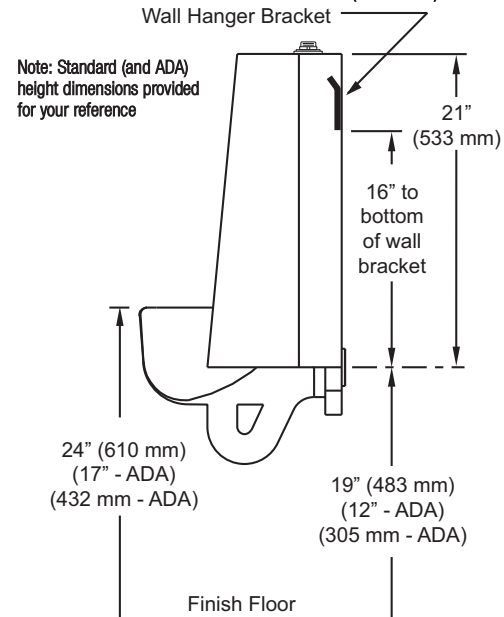

- Wall must be properly reinforced to support urinal.
- Determine position for new wall hanger bracket and mark hole locations.

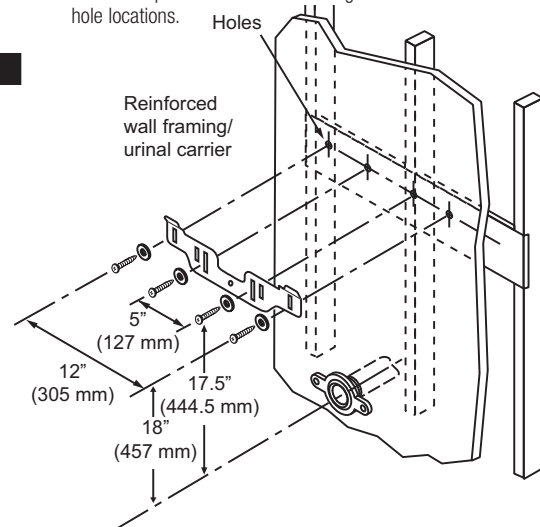

- Drill holes in wall (use wall anchors if needed).
- Mount and level wall hanger bracket using mounting screws and washers (included).

3. INSTALL NEW URINAL

- Install urinal on wall hanger bracket and secure bottom of urinal with bolts.

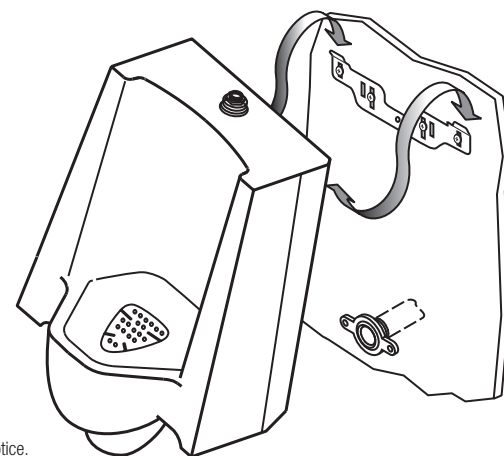

Note: Check if urinal is level. If not, adjust bracket.

▲ CAUTION! Do not overtighten the bolts. Breakage and chipping of vitreous china can occur.

Hand tighten hex end into acorn nut before carefully securing and tightening bolts

4. COMPLETING THE INSTALLATION

- Install flush valve to manufacturer's installation instructions.
- Turn on water supply valve.
- Flush urinal a few times and check all connections for water seepage.
- Caulk urinal perimeter where urinal meets the wall surface to provide a suitable hygienic seal.
- Drop in Urinal Fragrance pad (included).
- Recheck for leaks for a few days.
- Record model number for reference and fill out and send in warranty card.

CARE AND CLEANING OF VITREOUS CHINA

Clean urinals with a cleaner safe for vitreous china such as Sloan's Waterfree Urinal Cleaner/Deodorizer. Spray and wipe clean using soft cloth. Soft abrasive cleaners may be used to remove stains.

LIMITED WARRANTY

Sloan Valve Company warrants its Flushometer Products to be made of first class materials, free from defects of material or workmanship under normal use and to perform the service for which they are intended in a thoroughly reliable and efficient manner when properly installed and serviced, for a period of three years from date of purchase. During this period, Sloan Valve Company will, at its option, repair or replace any part or parts which prove to be thus defective if returned to Sloan Valve Company, at customer's cost, and this shall be the sole remedy available under this warranty. No claims will be allowed for labor, transportation or other incidental costs. This warranty extends only to persons or organizations who purchase Sloan Valve Company's products directly from Sloan Valve Company for purpose of resale.

THERE ARE NO WARRANTIES WHICH EXTEND BEYOND THE DESCRIPTION ON THE FACE HEREOF. IN NO EVENT IS SLOAN VALVE COMPANY RESPONSIBLE FOR ANY CONSEQUENTIAL DAMAGES OF ANY MEASURE WHATSOEVER.

NOTE: IN NO EVENT SHALL THE SLOAN VALVE COMPANY BE LIABLE FOR INCIDENTAL DAMAGES, RESULTING FROM IMPROPER INSTALLATION, OR FOR DAMAGES CAUSED BY NEGLIGENCE, ABUSE OR ALTERATION.

SLOAN®

SLOAN VALVE COMPANY

10500 Seymour Avenue
Franklin Park, IL 60131
Phone: 1-800-9-VALVE-9 (982-5839)
or 1-847-671-4300
Fax: 1-800-447-8329 or 1-847-671-4380
www.sloanvalve.com

The information contained in this document is subject to change without notice.

Instalación de Mingitorio

▲ ADVERTENCIA: Cualquier porcelana puede astillarse o romperse si los pernos o las tuercas se aprietan de más o si se maltratan. Pueden ocurrir lesiones personales si el producto se maneja erróneamente.

ANTES DE COMENZAR...

- Observe todos los códigos locales de plomería y construcción.
- Revise si el nuevo mingitorio presenta daños antes de su instalación.
- Asegúrese que la pared sea suficientemente fuerte para soportar el nuevo mingitorio antes de instalarlo. Refuerce o instale un portador de mingitorio de ser necesario.
- Las dimensiones cumplen con el estándar ASME A112.19.2

USTED NECESITA...

- Taladro eléctrico (preferible un martillo perforador 1/2" VSR de uso pesado si se monta en pared de concreto)
- Brocas para mampostería de alta velocidad o punta de carburo si se monta en pared de concreto.
- Espátula para masilla o raspador filoso
- Destornilladores (Phillips y plano)
- Lentes de seguridad
- Cinta de medir y marcador
- Nivel (mínimo preferido 24")
- Pistola para calafatear y masilla
- Pinzas regulables, llave ajustable y cuchillo multiusos.
- Limpiador de desagüe manual o eléctrico
- Pueden requerirse materiales y herramientas adicionales para preparación y refuerzo.

Nota: Requisitos del sistema de plomería
Presión mínima de flujo: 25 PSI

▲ ADVERTENCIA: Pueden escapar gases peligrosos por la tubería de drenaje si no se instala rápidamente el mingitorio nuevo. Revise sus códigos locales de plomería. Arreglo temporal: coloque un trapo en el agujero de tubo de drenaje.

INSTALACIONES DE REPUESTO

1. REMUEVA EL MINGITORIO EXISTENTE

- Cierre el suministro de agua.
- Desconecte la válvula de descarga.
- Corte la masilla por todo el perímetro del mingitorio existente usando el cuchillo multiusos para soltar el mingitorio de la superficie de la pared.
- Remueva cualesquier pernos de sujeción que puedan estar soportando el mingitorio en la parte inferior.
- Remueva el mingitorio de la pared.
- Remueva el soporte de colgar existente.
- Usando el raspador filoso o la espátula para masilla, remueva por completo la masilla restante de la pared.
- Remueva la brida y el empaque de salida existentes y elimínelos.

2. REVISE LAS DIMENSIONES DE PREPARACIÓN

- Revise las dimensiones de preparación. Haga los ajustes que se requieran a la alimentación de agua para acomodar la válvula de descarga.

3. LIMPIE EL DESAGÜE

- Limpie el tubo de drenaje usando un limpiador manual o mecánico para asegurarse que el tubo esté despejado.
- Proceda a INSTALACIONES NUEVAS.

INSTALACIONES NUEVAS

1. INSTALE LA BRIDA Y EL EMPAQUE DE SALIDA

- Remueva el trapo temporal (si se utilizó) del agujero del tubo de drenaje.
- Aplique sellador de rosca a las roscas del tubo de drenaje e instale la nueva brida de salida en el tubo. Ponga el empaque en la brida de salida.

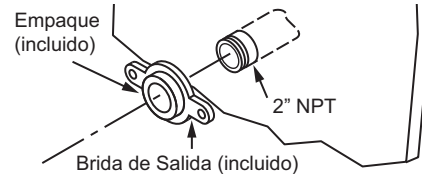

2. INSTALE EL NUEVO SOPORTE (INCLUIDO)

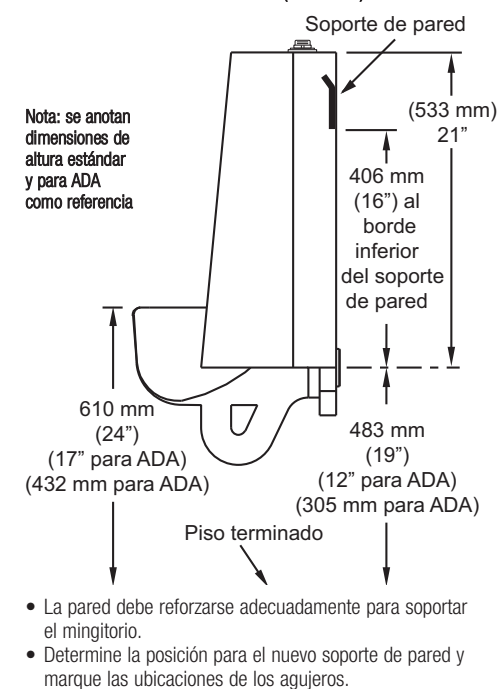

- La pared debe reforzarse adecuadamente para soportar el mingitorio.
- Determine la posición para el nuevo soporte de pared y marque las ubicaciones de los agujeros.

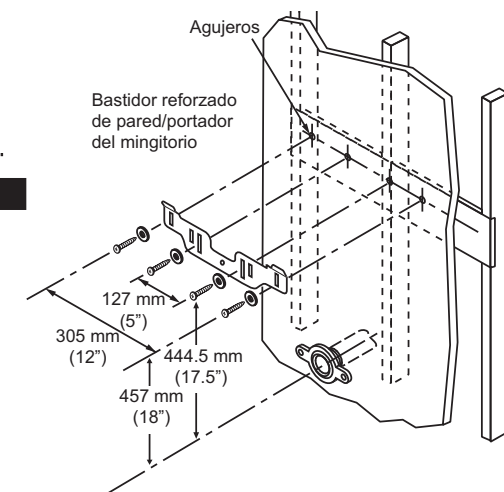

- Taladre agujeros en la pared (use taquetes si se requiere)
- Monte y nivele el soporte de pared usando los tornillos y arandelas de montaje (incluidos).

3. INSTALE EL NUEVO MINGITORIO

- Instale el mingitorio en el soporte de pared y asegúrelo en la parte inferior con pernos.

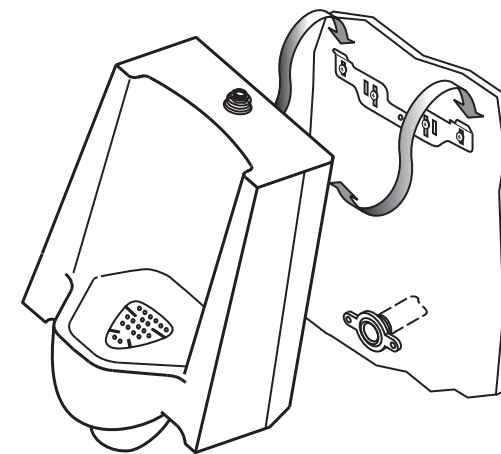

Nota: Revise si el mingitorio está nivelado. Si no lo está, ajuste el soporte.

▲ PRECAUCIÓN! No apriete los pernos en exceso. La porcelana puede romperse y astillarse.

4. COMPLETE LA INSTALACIÓN

- Instale la válvula de descarga de acuerdo con las instrucciones del fabricante.
- Abra la válvula de alimentación de agua.
- Descargue el mingitorio varias veces y revise todas las conexiones para verificar si presentan fugas.
- Ponga masilla en el perímetro del mingitorio donde éste se une a la superficie de la pared para aportar un sello higiénico adecuado.
- Coloque la plantilla de fragancia (incluida).
- Siga revisando si hay fugas por varios días.
- Registre el número de modelo como referencia y llene y envíe la tarjeta de garantía.

CUIDADO Y LIMPIEZA DE LA PORCELANA

Limpie los mingitorios con un limpiador que sea seguro para porcelana, como el Desodorante/Limpiador para Mingitorios Sloan Waterfree. Rocíe y talle con un trapo suave. Se pueden utilizar limpiadores abrasivos suaves para remover manchas.

GARANTÍA LIMITADA

Sloan Valve Company garantiza que sus Productos de Fluxómetro están hechos con materiales de primera clase, libres de defectos en material o mano de obra bajo uso normal y que prestan el servicio para el que fueron fabricados en una forma totalmente eficiente y confiable siempre que se instalen adecuadamente y se les dé el servicio adecuado, por un periodo de tres años a partir de la fecha de compra. Durante este periodo Sloan, a su discreción, reparará o reemplazará cualquier parte o partes que se comprueben que estén defectuosas si se devuelven a Sloan a costo del cliente, y éste será el único recurso correctivo que se ofrece con esta garantía. No se aceptan reclamos por mano de obra, transporte u otros costos incidentales. La presente garantía se extiende únicamente a personas u organizaciones que compren los productos de Sloan Valve Company directamente de Sloan Valve Company con fines de reventa.

NO EXISTEN MÁS GARANTÍAS QUE SE EXTIENDAN MÁS ALLÁ DE LA QUE SE DESCRIBIÓ ANTERIORMENTE. EN NINGÚN CASO SLOAN VALVE COMPANY ES RESPONSABLE POR CUALQUIER DAÑO CONSECUENTE DE CUALQUIER CLASE

NOTA: EN NINGÚN CASO SLOAN VALVE COMPANY SERÁ RESPONSABLE POR DAÑOS INCIDENTALES QUE RESULTEN DE INSTALACIÓN INADECUADA O POR DAÑOS CAUSADOS POR NEGLIGENCIA, ABUSO O ALTERACIONES.

Copyright © 2009 Sloan Valve Company
Printed in the U.S.A. Rev. 0a (09/09)
HEU I.I. Code No. 0816421

Rear Spud Urinal Installation Instructions

▲ WARNING: Any vitreous china can chip or break if the bolts or nuts are over-tightened or if mishandled. Personal injury can occur if product is mishandled.

BEFORE YOU START...

- Observe all local plumbing and building codes.
- Check for any damage to the new urinal before installation.
- Make sure the wall is strong enough to support the new urinal prior to installation. Reinforce or install a urinal carrier if necessary.
- Urinal complies to ASME Standard A112.19.2

WHAT YOU WILL NEED...

- Electric Drill (heavy duty 1/2" VSR hammer drill preferred if mounting to concrete wall)
- High Speed or carbide tipped masonry bits if mounting to concrete wall
- Putty knife or sharp scraper
- Screwdrivers (Phillips and flat head)
- Safety glasses
- Measuring tape and marker
- Level (24" minimum preferred)
- Caulking gun and caulk
- Channel lock pliers, adjustable wrench, and utility knife
- Manual or electric drain cleaner
- Additional materials and tools may be required for rough-in and reinforcing.

NOTE: Plumbing System Requirements
√ Minimum **Flowing** Pressure: 25 PSI

▲ WARNING: Hazardous gases can escape through the waste pipe if new urinal is not installed quickly. A temporary fix: place a rag in the waste pipe hole.

RETROFIT INSTALLATIONS

1. REMOVE EXISTING URINAL

- Turn off the water supply.
- Disconnect the flush valve.
- Cut caulk all around existing urinal using utility knife to release urinal from wall surface.
- Remove any attaching bolts that may be holding the urinal at the bottom.
- Remove urinal from wall.
- Remove existing hanger bracket.
- Using sharp scraper or putty knife, completely remove all remaining caulk from wall.
- Remove existing outlet flange and gasket and discard.

2. CHECK ROUGH-IN DIMENSIONS

- Check rough-in dimensions. Make any adjustments to water supply to accommodate flush valve as necessary.

3. CLEAN DRAIN

- Clean out waste pipe using hand or power cleaner to be sure pipe is clear.
- Proceed to NEW INSTALLATIONS.

NEW INSTALLATIONS

1. INSTALL OUTLET FLANGE AND GASKET

- Remove the temporary rag (if used) from the waste pipe hole.
- Apply thread sealant to waste pipe threads and install new outlet flange on pipe.

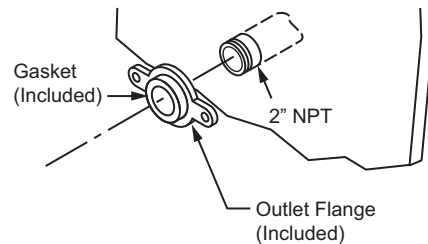

2. INSTALL NEW WALL HANGER BRACKET (INCLUDED)

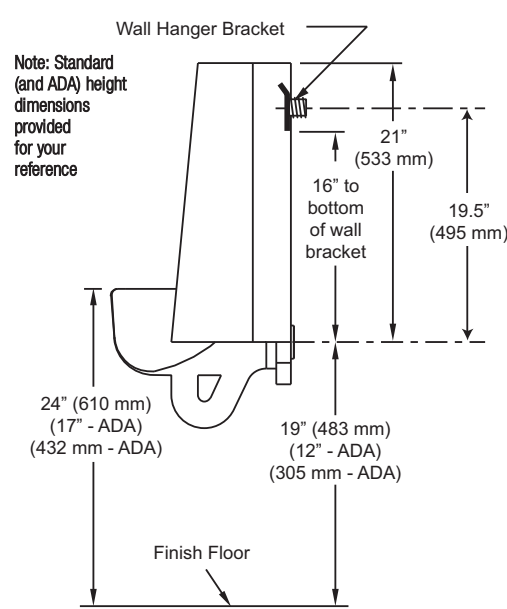

- Wall must be properly reinforced to support urinal.
- Determine position for new wall hanger bracket and mark hole locations.

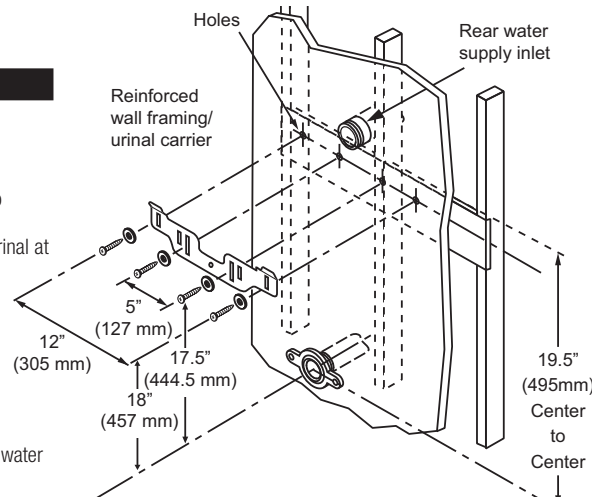

- Drill holes in wall (use wall anchors if needed).
- Mount and level wall hanger bracket using mounting screws and washers (included).

3. INSTALL NEW URINAL

- Install urinal on wall hanger bracket and secure bottom of urinal with bolts.

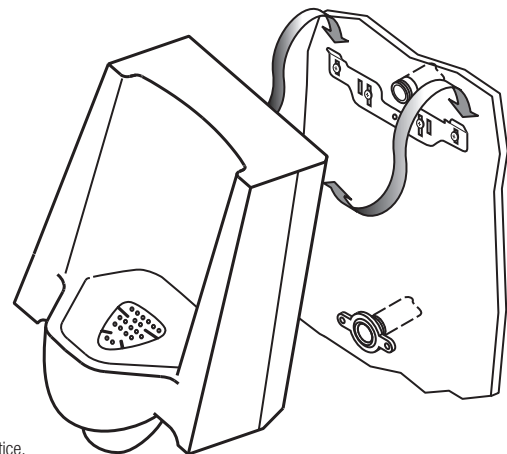

Note: Check if urinal is level. If not, adjust bracket.

▲ CAUTION! Do not overtighten the bolts. Breakage and chipping of vitreous china can occur.

Hand tighten hex end into acorn nut before carefully securing and tightening bolts

4. COMPLETING THE INSTALLATION

- Install flush valve to manufacturer's installation instructions.
- Turn on water supply valve.
- Flush urinal a few times and check all connections for water seepage.
- Caulk urinal perimeter where urinal meets the wall surface to provide a suitable hygienic seal.
- Drop in Urinal Fragrance pad (included).
- Recheck for leaks for a few days.
- Record model number for reference and fill out and send in warranty card.

CARE AND CLEANING OF VITREOUS CHINA

Clean urinals with a cleaner safe for vitreous china such as Sloan's Waterfree Urinal Cleaner/Deodorizer. Spray and wipe clean using soft cloth. Soft abrasive cleaners may be used to remove stains.

LIMITED WARRANTY

Sloan Valve Company warrants its Flushometer Products to be made of first class materials, free from defects of material or workmanship under normal use and to perform the service for which they are intended in a thoroughly reliable and efficient manner when properly installed and serviced, for a period of three years from date of purchase. During this period, Sloan Valve Company will, at its option, repair or replace any part or parts which prove to be thus defective if returned to Sloan Valve Company, at customer's cost, and this shall be the sole remedy available under this warranty. No claims will be allowed for labor, transportation or other incidental costs. This warranty extends only to persons or organizations who purchase Sloan Valve Company's products directly from Sloan Valve Company for purpose of resale.

THERE ARE NO WARRANTIES WHICH EXTEND BEYOND THE DESCRIPTION ON THE FACE HEREOF. IN NO EVENT IS SLOAN VALVE COMPANY RESPONSIBLE FOR ANY CONSEQUENTIAL DAMAGES OF ANY MEASURE WHATSOEVER.

NOTE: IN NO EVENT SHALL THE SLOAN VALVE COMPANY BE LIABLE FOR INCIDENTAL DAMAGES, RESULTING FROM IMPROPER INSTALLATION, OR FOR DAMAGES CAUSED BY NEGLIGENCE, ABUSE OR ALTERATION.

SLOAN®

SLOAN VALVE COMPANY

10500 Seymour Avenue
Franklin Park, IL 60131
Phone: 1-800-9-VALVE-9 (982-5839)
or 1-847-671-4300
Fax: 1-800-447-8329 or 1-847-671-4380
www.sloanvalve.com

The information contained in this document is subject to change without notice.

Instalación de Mingitorio con Spud Trasero

▲ ADVERTENCIA: Cualquier porcelana puede astillarse o romperse si los pernos o las tuercas se aprietan de más o si se maltratan. Pueden ocurrir lesiones personales si el producto se maneja erróneamente.

ANTES DE COMENZAR...

- Observe todos los códigos locales de plomería y construcción.
- Revise si el nuevo mingitorio presenta daños antes de su instalación.
- Asegúrese que la pared sea suficientemente fuerte para soportar el nuevo mingitorio antes de instalarlo. Refuerce o instale un portador de mingitorio de ser necesario.
- Las dimensiones cumplen con el estándar ASME A112.19.2.

USTED NECESITA...

- Taladro eléctrico (preferible un martillo perforador 1/2" VSR de uso pesado si se monta en pared de concreto)
- Brocas para mampostería de alta velocidad o punta de carburo si se monta en pared de concreto.
- Espátula para masilla o raspador filoso
- Destornilladores (Phillips y plano)
- Lentes de seguridad
- Cinta de medir y marcador
- Nivel (mínimo preferido 24")
- Pistola para calafatear y masilla
- Pinzas regulables, llave ajustable y cuchillo multiusos.
- Limpiador de desagüe manual o eléctrico
- Pueden requerirse materiales y herramientas adicionales para preparación y refuerzo.

Nota: Requisitos del sistema de plomería
Presión mínima de flujo: 25 PSI

▲ ADVERTENCIA: Pueden escapar gases peligrosos por la tubería de drenaje si no se instala rápidamente el mingitorio nuevo. Revise sus códigos locales de plomería. Arreglo temporal: coloque un trapo en el agujero de tubo de drenaje.

INSTALACIONES DE REPUESTO

1. REMUEVA EL MINGITORIO EXISTENTE

- Cierre el suministro de agua.
- Desconecte la válvula de descarga.
- Corte la masilla por todo el perímetro del mingitorio existente usando el cuchillo multiusos para soltar el mingitorio de la superficie de la pared.
- Remueva cualesquier pernos de sujeción que puedan estar soportando el mingitorio en la parte inferior.
- Remueva el mingitorio de la pared.
- Remueva el soporte de colgar existente.
- Usando el raspador filoso o la espátula para masilla, remueva por completo la masilla restante de la pared.
- Remueva la brida y el empaque de salida existentes y elimínelos.

2. REVISE LAS DIMENSIONES DE PREPARACIÓN

- Revise las dimensiones de preparación. Haga los ajustes que se requieran a la alimentación de agua para acomodar la válvula de descarga.

3. LIMPIE EL DESAGÜE

- Limpie el tubo de drenaje usando un limpiador manual o mecánico para asegurarse que el tubo esté despejado.
- Proceda a INSTALACIONES NUEVAS.

INSTALACIONES NUEVAS

1. INSTALE LA BRIDA Y EL EMPAQUE DE SALIDA

- Remueva el trapo temporal (si se utilizó) del agujero del tubo de drenaje.
- Aplique sellador de rosca a las rosas del tubo de drenaje e instale la nueva brida de salida en el tubo. Ponga el empaque en la brida de salida.

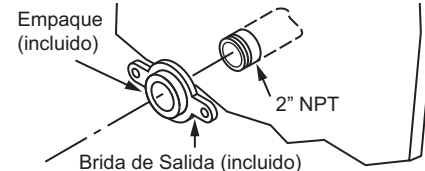

2. INSTALE EL NUEVO SOPORTE DE PARED (INCLUIDO)

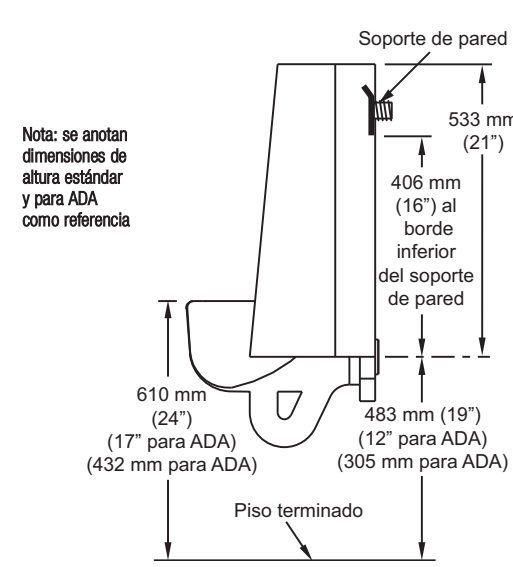

- La pared debe reforzarse adecuadamente para soportar el mingitorio.
- Determine la posición para el nuevo soporte de pared y marque las ubicaciones de los agujeros.

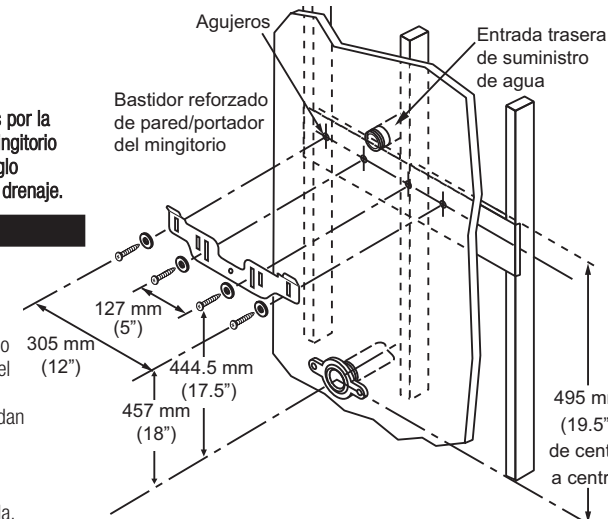

- Taladre agujeros en la pared (use taquetes si se requiere)
- Monte y nivele el soporte de pared usando los tornillos y arandelas de montaje (incluidos)

3. INSTALE EL NUEVO MINGITORIO

- Instale el mingitorio en el soporte de pared y asegúrelo en la parte inferior con pernos.

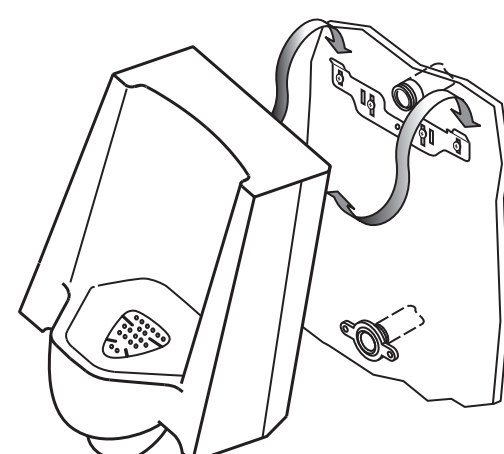

Nota: Revise si el mingitorio está nivelado. Si no lo está, ajuste el soporte.

PRECAUCION! No apriete los pernos en exceso. La porcelana puede romperse y astillarse.

4. COMPLETE LA INSTALACIÓN

- Instale la válvula de descarga de acuerdo con las instrucciones del fabricante.
- Abra la válvula de alimentación de agua.
- Descargue el mingitorio varias veces y revise todas las conexiones para verificar si presentan fugas.
- Ponga masilla en el perímetro del mingitorio donde éste se une a la superficie de la pared para aportar un sello higiénico adecuado.
- Coloque la plantilla de fragancia (incluida).
- Siga revisando si hay fugas por varios días.
- Registre el número de modelo como referencia y llene y envíe la tarjeta de garantía.

CUIDADO Y LIMPIEZA DE LA PORCELANA

Limpie los mingitorios con un limpiador que sea seguro para porcelana, como el Desodorante/Limpiador para Mingitorios Sloan Waterfree. Rocíe y talle con un trapo suave. Se pueden utilizar limpiadores abrasivos suaves para remover manchas.

GARANTÍA LIMITADA

Sloan Valve Company garantiza que sus Productos de Fluxómetro están hechos con materiales de primera clase, libres de defectos en material o mano de obra bajo uso normal y que prestan el servicio para el que fueron fabricados en una forma totalmente eficiente y confiable siempre que se instalen adecuadamente y se les dé el servicio adecuado, por un periodo de tres años a partir de la fecha de compra. Durante este periodo Sloan, a su discreción, reparará o reemplazará cualquier parte o partes que se comprueben que estén defectuosas si se devuelven a Sloan a costo del cliente, y éste será el único recurso correctivo que se ofrece con esta garantía. No se aceptan reclamos por mano de obra, transporte u otros costos incidentales. La presente garantía se extiende únicamente a personas u organizaciones que compren los productos de Sloan Valve Company directamente de Sloan Valve Company con fines de reventa.

NO EXISTEN MÁS GARANTÍAS QUE SE EXTIENDAN MÁS ALLÁ DE LA QUE SE DESCRIBIÓ ANTERIORMENTE. EN NINGÚN CASO SLOAN VALVE COMPANY ES RESPONSABLE POR CUALQUIER DAÑO CONSECUENTE DE CUALQUIER CLASE

NOTA: EN NINGÚN CASO SLOAN VALVE COMPANY SERÁ RESPONSABLE POR DAÑOS INCIDENTALES QUE RESULTEN DE INSTALACIÓN INADECUADA O POR DAÑOS CAUSADOS POR NEGLIGENCIA, ABUSO O ALTERACIONES.

Copyright © 2009 Sloan Valve Company
Impreso en los EE.UU. Rev. 0a (09/09)
HEU I.I. No. Código 0816421

INSTALLATION INSTRUCTIONS FOR PISTON TYPE FLUSHOMETER EXPOSED CLOSET AND URINAL INSTALLATIONS



**Closet Flushometer
for 1 1/2" Top Spud**
Models 111, 115, 116



**Urinal Flushometer
for 1 1/4" Top Spud**
Model 180

**Urinal Flushometer
for 3/4" Top Spud**
Model 186



**Closet Flushometer
for 1 1/2" Back Spud**
Model 120

LIMITED WARRANTY

Unless otherwise noted, Sloan Valve Company warrants its products, manufactured and sold for commercial or industrial uses, to be free from defects of material and workmanship for a period of three (3) years (one year for SF faucets, special finish and PWT electronics and 30 days on PWT software) from the date of first purchase. During this period, Sloan Valve Company will, at its option, repair, replace, or refund the purchase price of any produce which fails to conform with this warranty under normal use and service. This shall be the sole and exclusive remedy under this warranty. Products must be returned to Sloan Valve Company, at customer's cost. No claims will be allowed for labor, transportation or other costs. This warranty extends only to persons or organizations that purchase Sloan Valve Company's products directly from Sloan Valve Company for purpose of resale. This warranty does not cover the life of batteries.

THERE ARE NO WARRANTIES WHICH EXTEND BEYOND THE DESCRIPTION ON THE FACE HEREOF. IN NO EVENT IS SLOAN VALVE COMPANY RESPONSIBLE FOR ANY CONSEQUENTIAL DAMAGES OF ANY MEASURE WHATSOEVER.

ROUGH-IN

MODEL 111

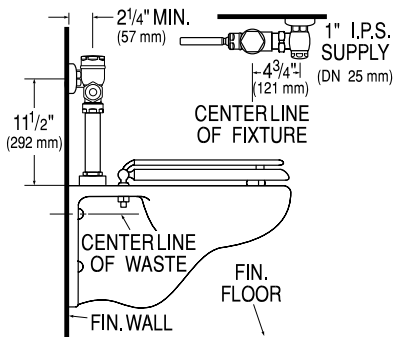

MODELS 115 & 116

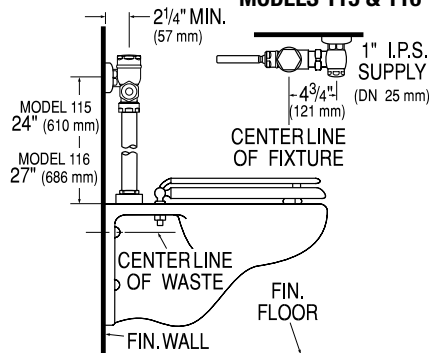

MODEL 120

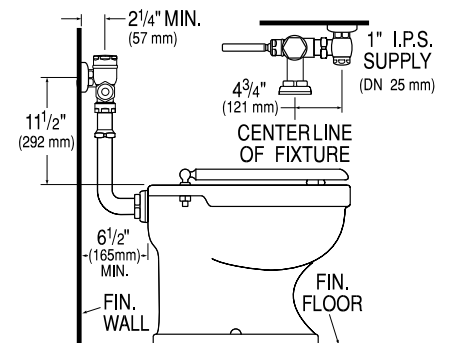

MODEL 180

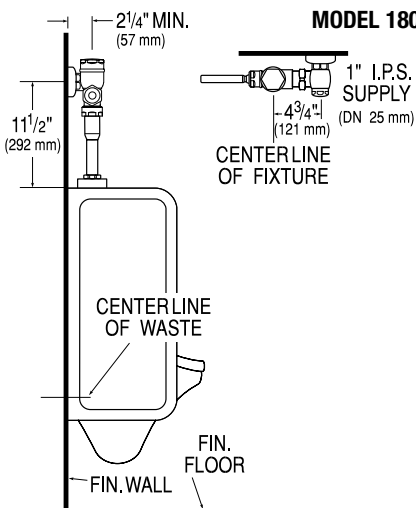

MODEL 186

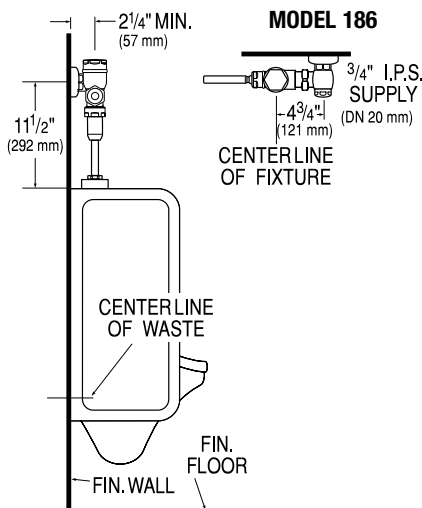

!!! IMPORTANT !!!
WHEN MOUNTED ON AN ADA ACCESSIBLE BOWL, THE ROUGH-IN SHOULD BE NO HIGHER THAN 37 1/2" OR THE HANDLE WILL EXCEED MAXIMUM HEIGHT ALLOWANCES UNDER ADA GUIDELINES.

PRIOR TO INSTALLATION

Before you install the Sloan Crown II and Crown Flushometer, be sure the items listed below are installed. Also, refer to the rough-in diagrams.

- Closet/urinal fixture
- Drain line
- Water supply line

IMPORTANT:

- **ALL PLUMBING SHOULD BE INSTALLED IN ACCORDANCE WITH APPLICABLE CODES AND REGULATIONS.**
- **WATER SUPPLY LINES MUST BE SIZED TO PROVIDE AN ADEQUATE VOLUME OF WATER FOR EACH FIXTURE.**
- **FLUSH ALL WATER LINES PRIOR TO MAKING CONNECTIONS.**

!!! IMPORTANT !!!

PROTECT THE FINISH OF SLOAN FLUSHOMETERS — DO NOT USE TOOTHED TOOLS TO INSTALL OR SERVICE THESE VALVES. USE A SLOAN A-50 SUPER-WRENCH™, SLOAN A-109 PLIER WRENCH OR SMOOTH JAWED SPUD WRENCH TO SECURE ALL COUPLINGS. ALSO SEE “CARE AND CLEANING” SECTION OF THIS MANUAL.

The Sloan Crown II and Crown Flushometer is designed to operate with 10 to 100 psi (69 to 689 kPa) of water pressure. **THE MINIMUM PRESSURE REQUIRED TO THE VALVE IS DETERMINED BY THE TYPE OF FIXTURE SELECTED.** Consult fixture manufacturer for minimum pressure requirements. Most Low Consumption water closets (1.6 gpf/6.0 Lpf) require a minimum flowing pressure of 25 psi (172 kPa).

!!! IMPORTANT !!!

WITH THE EXCEPTION OF CONTROL STOP INLET, DO NOT USE PIPE SEALANT OR PLUMBING GREASE ON ANY VALVE COMPONENT OR COUPLING!

!!! IMPORTANT !!!

NEVER OPEN CONTROL STOP TO WHERE THE FLOW FROM THE VALVE EXCEEDS THE FLOW CAPABILITY OF THE FIXTURE. IN THE EVENT OF A VALVE FAILURE, THE FIXTURE MUST BE ABLE TO ACCOMMODATE A CONTINUOUS FLOW FROM THE VALVE.

!!! IMPORTANT !!!

THIS PRODUCT CONTAINS MECHANICAL AND/OR ELECTRICAL COMPONENTS THAT ARE SUBJECT TO NORMAL WEAR. THESE COMPONENTS SHOULD BE CHECKED ON A REGULAR BASIS AND REPLACED AS NEEDED TO MAINTAIN THE VALVE'S PERFORMANCE.

TOOLS REQUIRED FOR INSTALLATION

- Straight blade screwdriver
- Sloan A-50 Super-Wrench™, Sloan A-109 Plier Wrench or smooth jawed spud wrench

1 - INSTALL OPTIONAL SWEAT SOLDER ADAPTER (ONLY IF YOUR SUPPLY PIPE DOES NOT HAVE A MALE THREAD)

- Measure from finished wall to C/L of Fixture Spud. Cut pipe 1¼" (32 mm) shorter than this measurement. Chamfer O.D. and I.D. of water supply pipe.
- Slide Threaded Adapter fully onto pipe.
- Sweat solder the Adapter to pipe.

!!! IMPORTANT !!!

With the exception of Control Stop Inlet, DO NOT use pipe sealant or plumbing grease on any valve component or coupling!

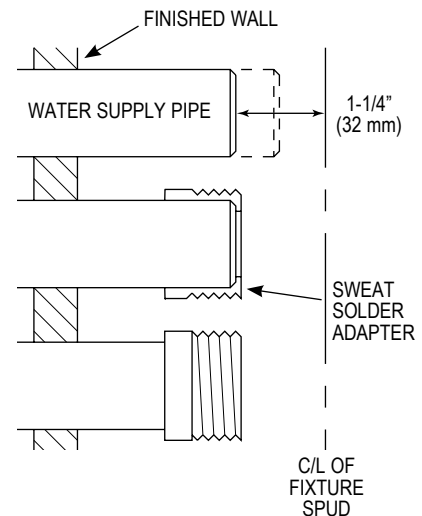

2 - INSTALL COVER TUBE, WALL FLANGE AND CONTROL STOP TO SUPPLY PIPE

- Measure from finished wall to first thread of Adapter or threaded supply pipe (dimension "X"). Cut Cover Tube to this length.
- Slide Cover Tube over pipe. Slide Wall Flange over Cover Tube until against wall.

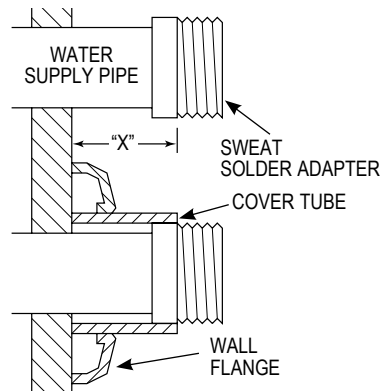

- Thread Control Stop onto pipe. Tighten with a wrench.
- Tighten Set Screw with a 1/16" hex wrench. DO NOT install Vandal Resistant Stop Cap at this time.

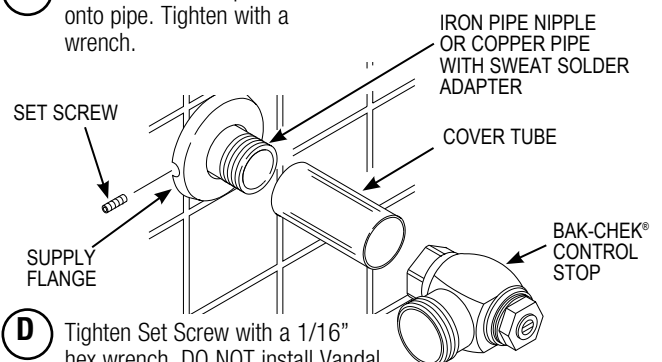

3 - INSTALL VACUUM BREAKER FLUSH CONNECTION

A Slide Spud Coupling, Nylon Slip Gasket, Rubber Gasket and Spud Flange over Vacuum Breaker Tube.

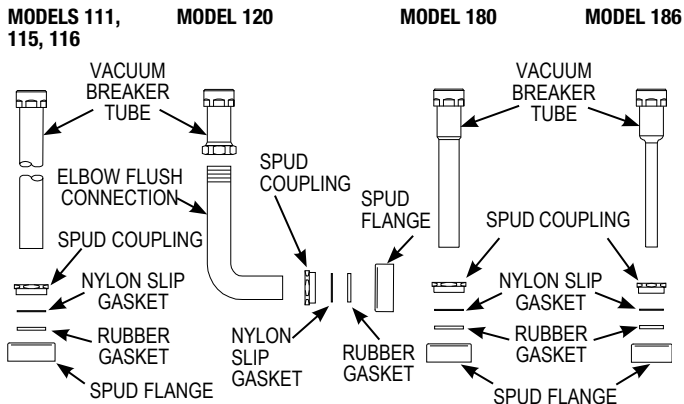

B Insert Tube into Fixture Spud.

C Hand tighten Spud Coupling onto Fixture Spud.

NOTE
IF CUTTING VACUUM BREAKER TUBE TO SIZE, NOTE THAT CRITICAL LINE (C/L) ON VACUUM BREAKER MUST TYPICALLY BE 6" (152 MM) ABOVE FIXTURE. CONSULT CODE FOR DETAILS.
ON VALVES FURNISHED LESS VACUUM BREAKER, (XYV VARIATION), CONNECT FLUSH TUBE TO THE BOTTOM OF THE VALVE USING THE SLIP GASKET SUPPLIED.

4 - INSTALL FLUSHOMETER

A Lubricate tailpiece O-ring with water. Insert Adjustable Tailpiece into Control Stop. Tighten Tailpiece Coupling by hand.

B Align flushometer directly above the vacuum breaker flush connection by sliding the flushometer body IN or OUT as needed. Tighten vacuum breaker coupling by hand.



NOTE
MAXIMUM ADJUSTMENT OF THE SLOAN ADJUSTABLE TAILPIECE IS 1/2" (13 MM) IN OR OUT FROM THE STANDARD 4-3/4" (121 MM) (CENTERLINE OF FLUSHOMETER TO CENTERLINE OF CONTROL STOP).
IF ROUGHING-IN MEASUREMENT EXCEEDS 5-1/4" (133 MM), CONSULT FACTORY FOR LONGER TAILPIECE.
IF A GROUND JOINT TAILPIECE HAS BEEN SPECIFIED (RECOMMENDED FOR SEAWATER APPLICATIONS), THERE IS NO LATERAL ADJUSTMENT; THEREFORE, THE 4 3/4" (121 MM) ROUGH-IN MUST BE EXACT.

C Align Flushometer body and securely tighten first the Tailpiece Coupling (1), then the Vacuum Breaker Coupling (2), and finally the Spud Coupling (3). Use a wrench to tighten these couplings in the order shown.

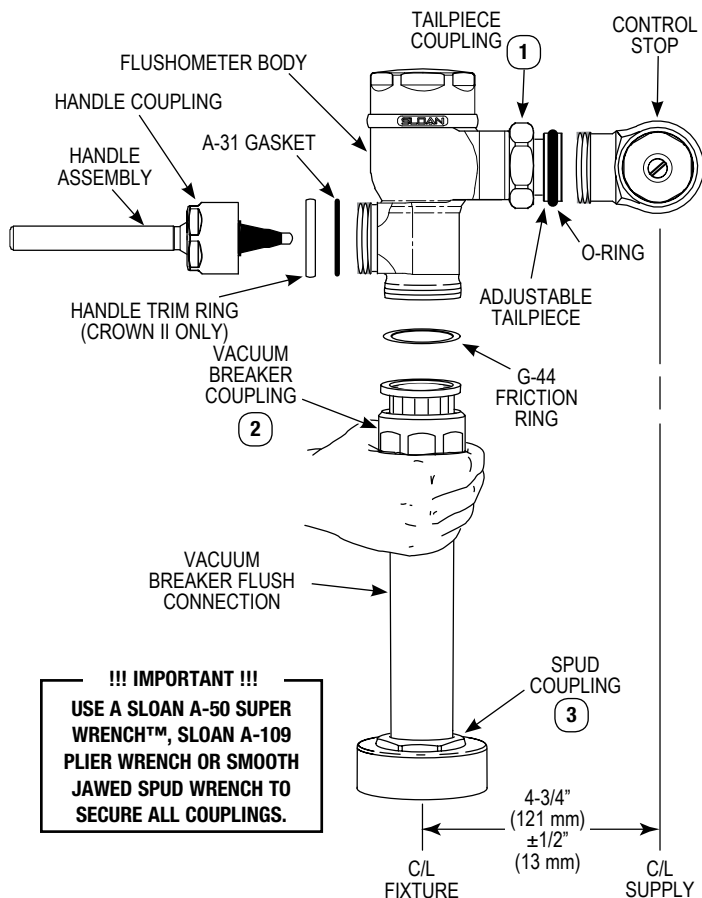

!!! IMPORTANT !!!
USE A SLOAN A-50 SUPER WRENCH™, SLOAN A-109 PLIER WRENCH OR SMOOTH JAWED SPUD WRENCH TO SECURE ALL COUPLINGS.

5 - INSTALL HANDLE ASSEMBLY

A Install handle assembly, handle trim Ring (Crown II flushometers only), and gasket to flushometer body. Tighten handle assembly securely.

!!! IMPORTANT !!!
USE A SLOAN A-50 SUPER WRENCH™, SLOAN A-109 PLIER WRENCH OR SMOOTH JAWED SPUD WRENCH TO SECURE HANDLE COUPLING.

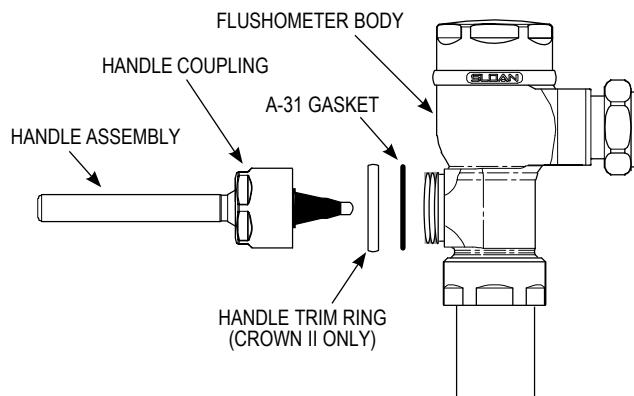

6 - FLUSH OUT SUPPLY LINE

- A** Make sure control stop is CLOSED.

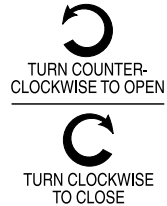
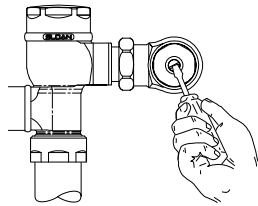

- B** Remove flushometer cover.

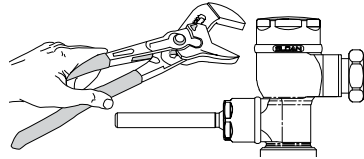

- C** Lift out the piston assembly.

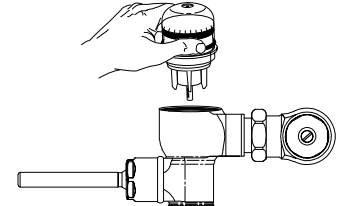

- D** Replace inner cover and re-install flushometer cover wrench tight. Open control stop to flush supply line. Close control stop and remove flushometer cover.

- E** Reinstall piston assembly and flushometer cover. Tighten flushometer cover wrench tight.

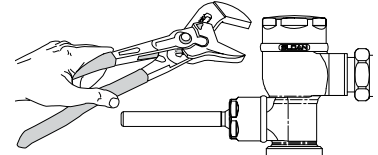

7 - ADJUST CONTROL STOP AND INSTALL VANDAL RESISTANT STOP CAP

- A** Open control stop COUNTERCLOCKWISE ½ turn from closed position.

- B** Activate flushometer.

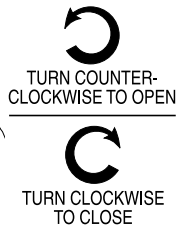
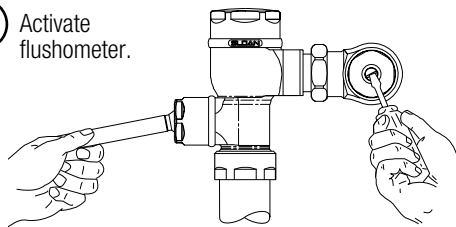

- C** Adjust control stop after each flush until the rate of flow delivered properly cleanses the fixture.

!!! IMPORTANT !!!

SLOAN'S FLUSHOMETER ARE ENGINEERED FOR QUIET OPERATION. EXCESSIVE WATER FLOW CREATES NOISE, WHILE TOO LITTLE WATER FLOW MAY NOT SATISFY THE NEEDS OF THE FIXTURE. PROPER ADJUSTMENT IS MADE WHEN PLUMBING FIXTURE IS CLEANED AFTER EACH FLUSH WITHOUT SPLASHING WATER OUT FROM THE LIP AND A QUIET FLUSHING CYCLE IS ACHIEVED.

NEVER OPEN CONTROL STOP TO WHERE THE FLOW FROM THE VALVE EXCEEDS THE FLOW CAPABILITY OF THE FIXTURE. IN THE EVENT OF A VALVE FAILURE, THE FIXTURE MUST BE ABLE TO ACCOMMODATE A CONTINUOUS FLOW FROM THE VALVE.

- D** Install locking vandal resistant control stop cap onto control stop.

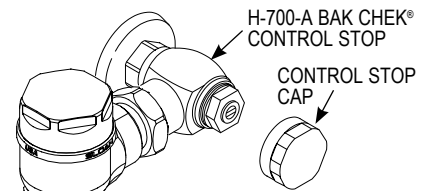

CARE AND CLEANING

DO NOT USE abrasive or chemical cleaners (including chlorine bleach) to clean Flushometers that may dull the luster and attack the chrome or special decorative finishes. Use **ONLY** mild soap and water, then wipe dry with clean cloth or towel.

While cleaning the bathroom tile, protect the Flushometer from any splattering of cleaner. Acids and cleaning fluids will discolor or remove chrome plating.

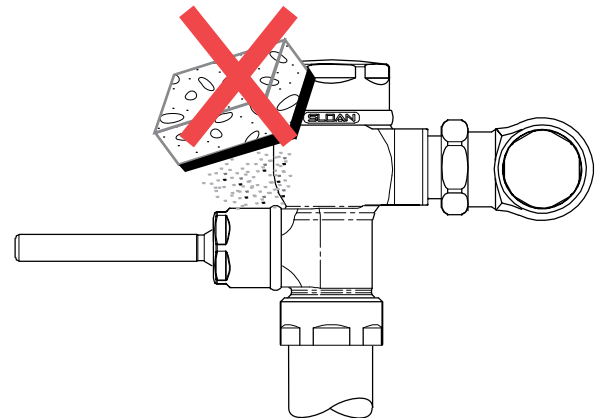

TROUBLESHOOTING GUIDE

1. PROBLEM: Valve does not function.

- CAUSE:** (a.) Control Stop or Main Valve is Closed.
(b.) Handle Assembly is worn.
(c.) Relief Valve is worn and sticking in UP position.

- SOLUTION:** (a.) Open Control Stop or Main Valve.
(b.) Install Sloan Handle Repair Kit (CR-1007) or replace Handle.
(c.) Replace Piston.

2. PROBLEM: Insufficient volume of water to adequately siphon fixture.

- CAUSE:** (a.) Control Stop not open enough.
(b.) Urinal Piston Parts inside a Closet Valve.
(c.) Low Consumption Valve installed on a non-Low Consumption fixture.
(d.) Inadequate volume or pressure at supply.

- SOLUTION:** (a.) Adjust Control Stop for desired delivery of water.
(b.) Replace Piston Parts with proper Closet Piston.
(c.) Replace with proper Flushometer. Crown II and Crown Flushometers are not available with flush volume higher than 1.6 gpf/6.0 Lpf.
(d.) Increase water pressure or supply (flow) to valve. Consult Factory for assistance.

IMPORTANT - LAWS AND REGULATIONS PROHIBIT THE USE OF HIGHER FLUSHING VOLUMES THAN LISTED ON FIXTURE OR FLUSHOMETER.

3. PROBLEM: Length of flush too short (Short Flushing) or Valve closes off immediately.

- CAUSE:** (a.) Piston Assembly is not hand-tight.
(b.) Enlarged Bypass orifice from corrosion or damage.
(c.) Urinal Piston in Closet Flushometer.
(d.) Low Consumption Valve installed on a non-Low Consumption fixture.
(e.) Handle Assembly worn.

- SOLUTION:** (a.) Screw the Piston Assembly hand-tight.
(b.) Install NEW Inside Parts Kit to correct problem and update flushometer.
(c.) Replace Piston with proper Closet Piston.
(d.) Replace with proper flushometer. Crown II and Crown flushometers are not available with flush volume higher than 1.6 gpf/6.0 Lpf.
(e.) Install Handle Repair Kit (CR-1007).

4. PROBLEM: Length of flush too long (Long Flushing) or fails to close off.

- CAUSE:** (a.) Piston is not seating properly or Bypass orifice is clogged because of foreign material, or Bypass orifice is clogged by an invisible gelatinous film from "over-treated" water.
(b.) Line pressure has dropped and is not sufficient to force Relief Valve to seat.
(c.) Main Seat is fouled with debris or is worn.

- SOLUTION:** (a.) Disassemble the working parts and wash thoroughly.
NOTE: Size of the orifice in the Bypass is of utmost importance for the proper metering of water into the upper chamber of the valve. Do not enlarge or damage this orifice. Replace Piston if cleaning does not correct problem.
(b.) Shut off all control stops until pressure has been restored, then open them again.
(c.) Clean or replace Main Seat.

5. PROBLEM: Leaking at Handle Assembly.

- CAUSE:** (a.) The B-85 Seal may have deteriorated.
(b.) Handle Gasket has been omitted.
(c.) Valve Handle Bushing is worn.
(d.) Handle Trim Ring is reversed preventing gasket from sealing (Crown II only).

- SOLUTION:** (a.) Install new B-85 Seal.
NOTE: The B-85 Seal will easily slide onto the Bushing if it is wet.
(b.) Install A-31 Handle Gasket or Sloan Handle Repair Kit (CR-1007).
(c.) Install Sloan Handle Repair Kit (CR-1007).
(d.) Flip Handle Trim Ring (CR-113) and reinstall Handle Assembly.

Refer to the Repair Parts and Maintenance Guide for additional Troubleshooting and Repair Part information.

**If further assistance is required,
please contact Sloan Technical Support at:
1-888-SLOAN-14 (1-888-756-2614)**

PARTS BREAKDOWN

Item No.	Part No.	Description
1	†	Valve Assembly
2	B-30-A	Handle Assembly
3A	CR-120	PVDPB (Polished Brass) Cover Trim Ring (Crown II only)
	CR-120	PVDBN (Brushed Nickel) Cover Trim Ring (Crown II only)
	CR-120	PVDSF (Satin Finish) Cover Trim Ring (Crown II only)
3B	CR-113	PVDPB (Polished Brass) Handle Trim Ring (Crown II only)
	CR-113	PVDBN (Brushed Nickel) Handle Trim Ring (Crown II only)
	CR-113	PVDSF (Satin Finish) Handle Trim Ring (Crown II only)
4	A-31	Handle Gasket — 48 per pkg.
5	H-700-A	Bak-Chek® Control Stop
6A	V-500-AA	1½" x 9" (38 mm x 229 mm) Vacuum Breaker Assembly CP (Model 111)‡
	V-500-AA	1½" x 21" (38 mm x 533 mm) Vacuum Breaker Assembly CP (Model 115)‡
	V-500-AA	1½" x 24" (38 mm x 610 mm) Vacuum Breaker Assembly CP (Model 116)‡
6B	V-500-AA	1¼" x 9" (32 mm x 229 mm) Vacuum Breaker Assembly CP (Model 180)‡
6C	V-500-AA	¾" x 9" (19 mm x 229 mm) Vacuum Breaker Assembly CP (Model 186)‡
6D	V-500-A	1½" (38 mm) Vacuum Breaker Assembly CP (Model 120)‡
7	F-109	1½" (38 mm) Elbow Flush Connection CP (Model 120)
8A	CR-1010-A	1½" (38 mm) Spud Coupling Assembly (Models 111, 115, 116 & 120)
8B	CR-1009-A	1¼" (32 mm) Spud Coupling Assembly (Model 180)
8C	CR-1008-A	¾" (19 mm) Spud Coupling Assembly (Model 186)
9	F-7	Supply Flange (supplied when valve is not ordered w/ sweat solder kit)
10	H-633-AA	1" (25 mm) Sweat Solder Kit & Cast Wall Flange w/ Set Screw (YBYC Variation)*
	H-636-AA	¾" (19 mm) Sweat Solder Kit & Cast Wall Flange w/ Set Screw (YBYC Variation)*
11	H-573-A	Locking Vandal Resistant Control Stop Cap CP §
	H-582	Locking Vandal Resistant Control Stop Cap CP •
Handle and Cover Trim Ring Kits		
	CR-132-A	CP (Chrome Plate) Handle/Cover Trim Ring Kit
	CR-132-A	PVDPB (Polished Brass) Handle/Cover Trim Ring Kit
	CR-132-A	PVDBN (Brushed Nickel) Handle/Cover Trim Ring Kit
	CR-132-A	PVDSF (Satin Chrome) Handle/Cover Trim Ring Kit

Handle Repair Kit

CR-1007 Handle Repair Kit

Piston Repair Kits

Please refer to the Sloan Repair and Maintenance Guide or Consult Factory

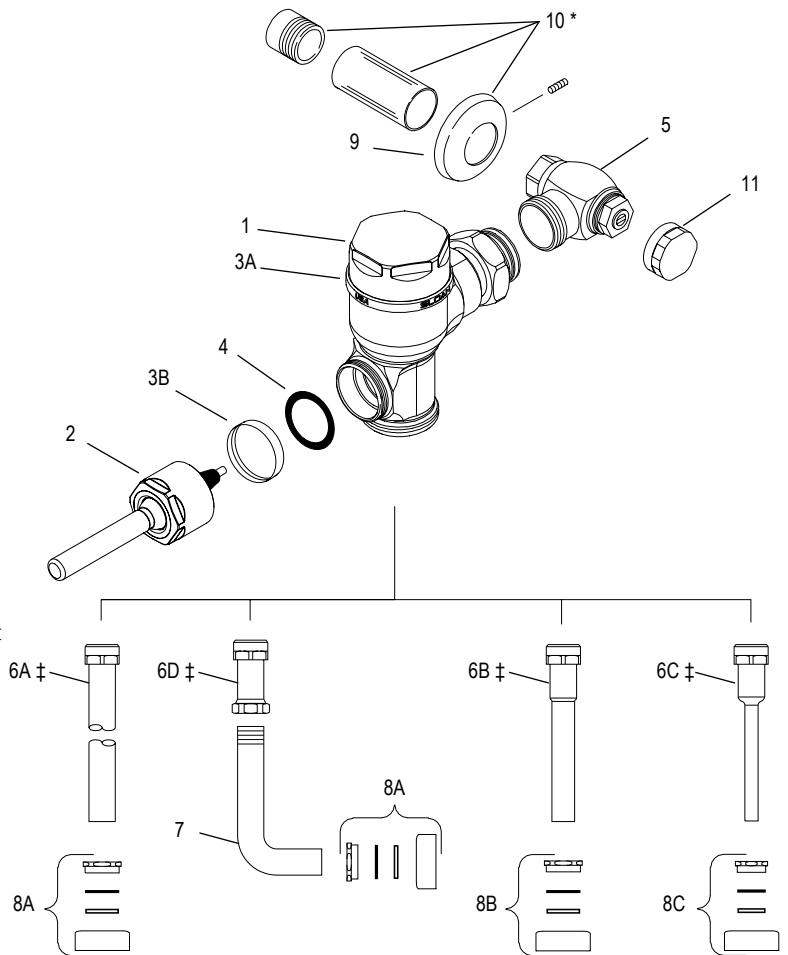

† Part number varies with valve model variation; consult factory.

‡ If valve was specified less vacuum breaker ("XYV" Variation), a straight flush tube is supplied in place of the vacuum breaker assembly. Consult Factory for part number.

§ For use w/H-700-A 1" & ¾" and H-600-A 1" Screwdriver Bak-Chek® Control Stops.

• For use w/H-600-A ¾" Screwdriver Bak-Chek® Control Stops.

* Furnished only when ordered with YBYC variation. For a complete listing of Crown II and Crown Flushometer Valve Components and Repair Kits, refer to Repair Parts and Maintenance Guide or consult your nearest plumbing wholesaler.

Manufactured in the U.S.A. by Sloan Valve Company under one or more of the following patents: U.S. Patents: 5,558,120; 6,460,825; 6,499,716; 6,550,744; 6,616,118; 6,675,827; 5,564,460; 5,730,415; D399,932; D470,222; D494,255; 6,550,744; CROWN II®, CROWN®, BAK-CHEK®.

The information contained in this document is subject to change without notice.

SLOAN • 10500 SEYMOUR AVENUE • FRANKLIN PARK, IL 60131

Phone: 1-800-9-VALVE-9 or 1-847-671-4300 • Fax: 1-800-447-8329 or 1-847-671-4380 • www.sloanvalve.com