

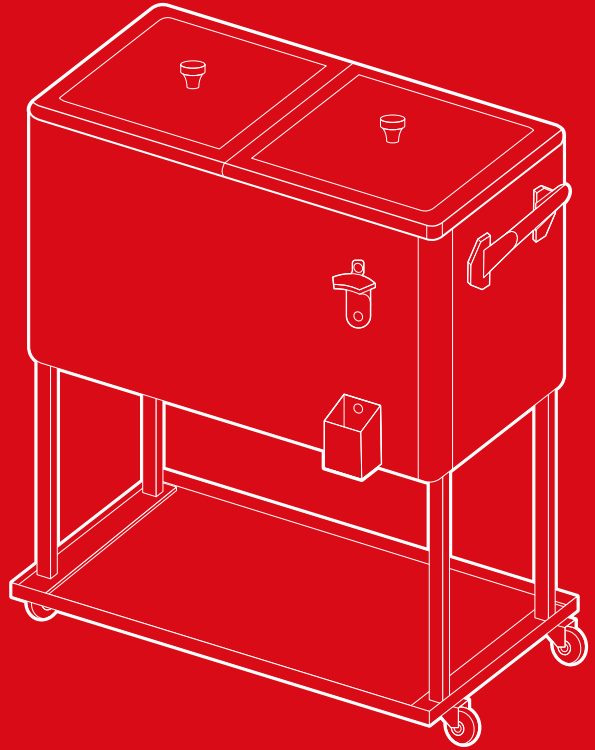

bestchoiceproducts



INSTRUCTION MANUAL

80-Quart
Rolling Cooler Cart

! NOTICE

Please retain these instructions for future reference.

- Drainage plug may occasionally drip a small amount of water over time.
- Please do not exceed the weight limitations of this item.
- Do not stand on or use any part of this item as a step ladder.
- Firmly secure all bolts, screws, and knobs before use.
- Reconfirm that all bolts, screws, and knobs are secure every 90 days.
- Do not use or store this item in the proximity of open flame or flammable/combustible chemicals.
- If any parts are missing, broken, damaged, or worn, stop using this item until repairs are made and/or factory replacement parts are installed.
- Do not use this item in a way inconsistent with the manufacturer's instructions as this could void the product warranty.

TOOLS REQUIRED



ALLEN WRENCH
(PROVIDED)



SMALL WRENCH
(PROVIDED)



132 LBS
CAPACITY



1 PERSON
ASSEMBLY



UP TO 30 MIN.
ASSEMBLY

HARDWARE

1 LONG SCREW



2 PCS

2 SCREW



24 PCS

3 DRAINAGE
PLUG



1 PC

4 BOTTLE
OPENER



1 PC

5 CASTER



2 PCS

6 LOCKING
CASTER



2 PCS

7 KNOB



2 PCS

PARTS

A COOLER

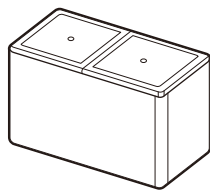

1 PC

B LEG

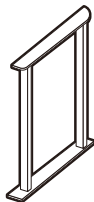

2 PCS

C TRAY

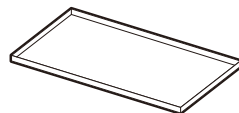

1 PC

D HANDLE

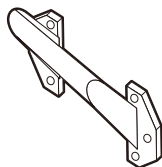

2 PCS

E CAP CATCHER

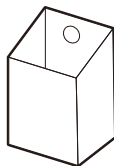

1 PC

PRODUCT ASSEMBLY

1

- Flip the part A cooler upside down.
Attach two part B legs with eight part 2 screws.

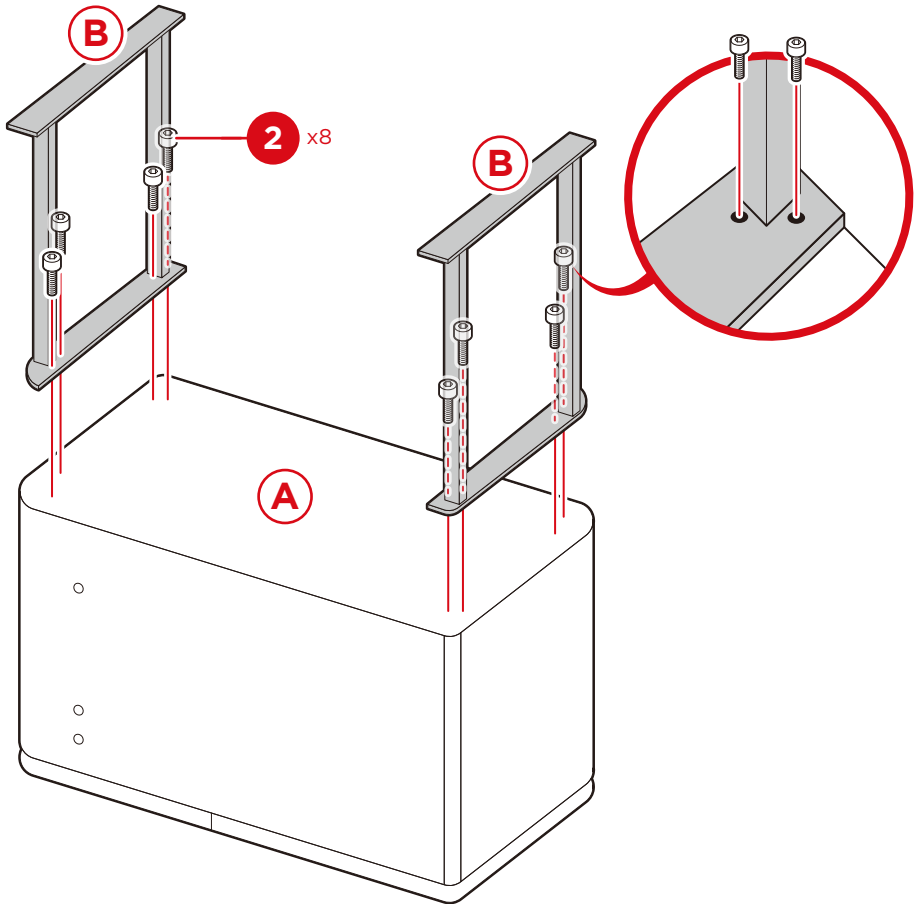

PRODUCT ASSEMBLY

2

Place the part C tray on the legs.

Screw two part 5 casters and two part 6 locking casters into the tray/legs.

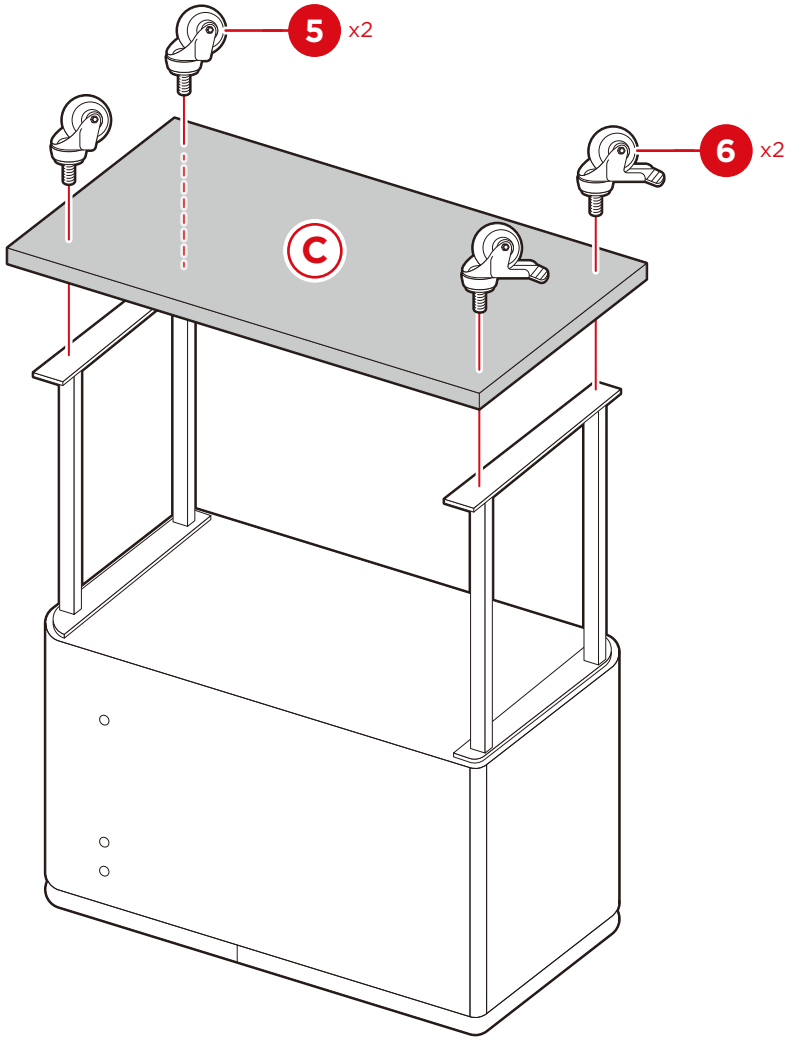

PRODUCT ASSEMBLY

3

Flip the cooler onto the casters.

Attach two part D handles with twelve part 2 screws.

Attach part 4 bottle opener and part E cap catcher with four part 2 screws.

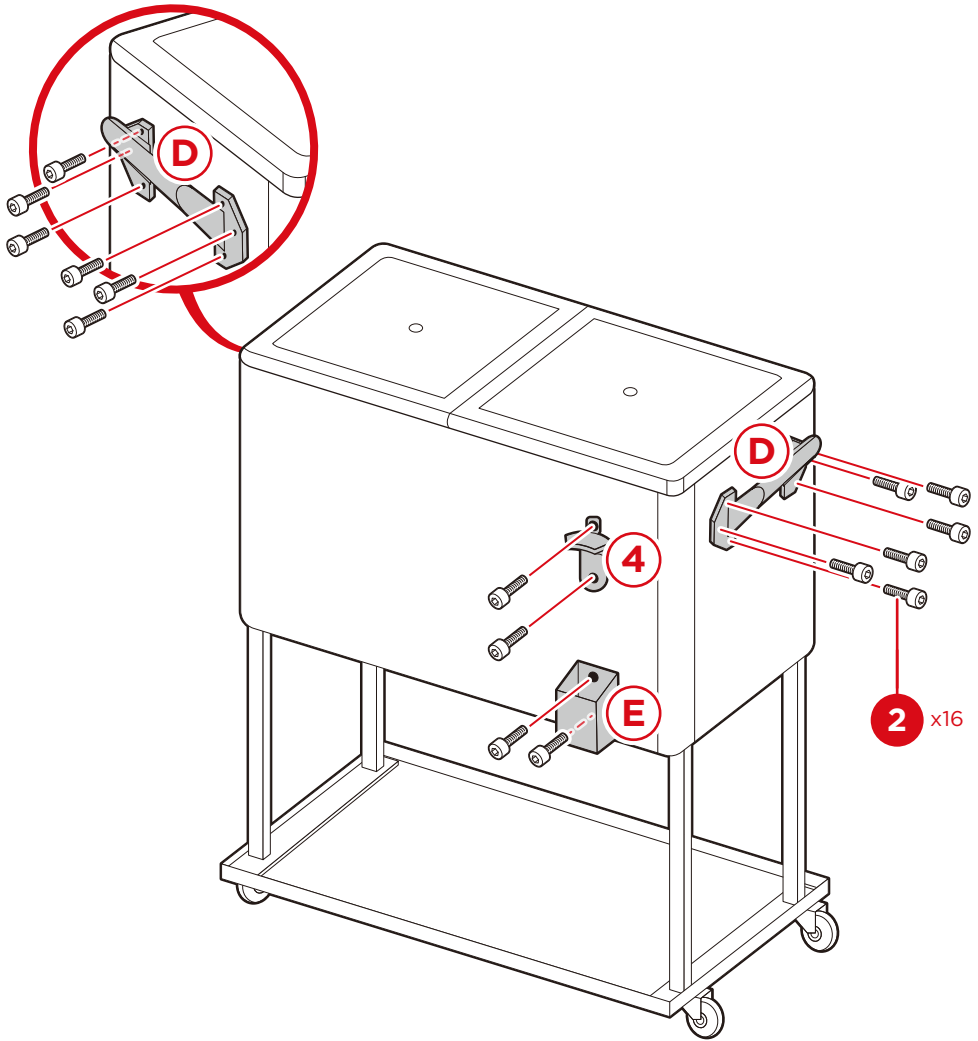

PRODUCT ASSEMBLY

4

Install the part 3 drainage plug and tighten the nut to secure it.
Attach two part 7 knobs with two part 1 screws.

NOTE: Knobs attach underneath the lids.

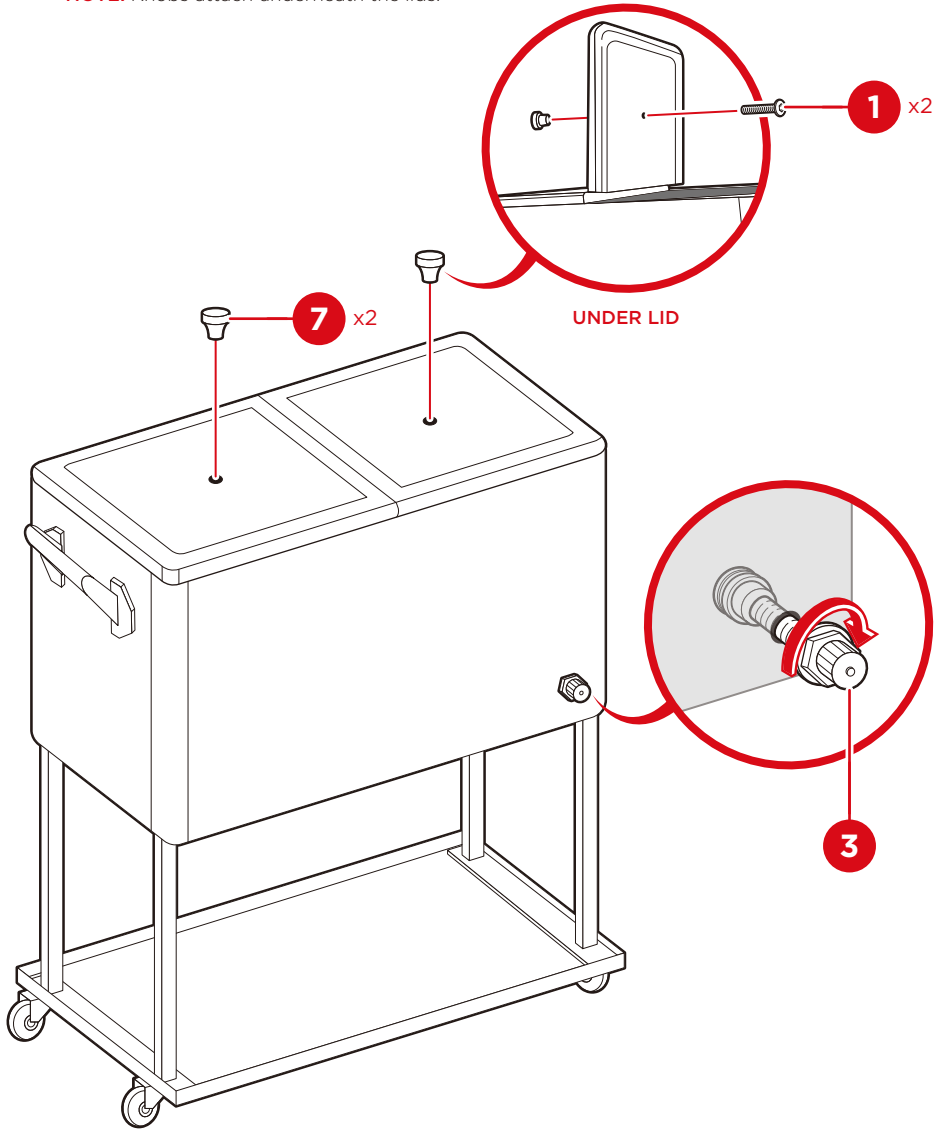



HELP CENTER



Question about your product? We're here to help. Visit us at:

help.bestchoiceproducts.com



Chat Support



Product Inquiry



Orders FAQ



Product Assembly



Returns & Refunds

PRODUCT WARRANTY INFORMATION

All items can be returned for any reason within 60 days of the receipt and will receive a full refund as long as the item is returned in its original product packaging and all accessories from its original shipment are included. All returned items will receive a full refund back to the original payment method. All returned items will not be charged a re-stocking fee.

All returned items require an RA (Return Authorization) number, which can only be provided by a Best Choice Products Customer Service Representative when the return request is submitted. Items received without an RA may not be accepted or may increase your return processing time. Once an item has been received by Best Choice Products, refunds or replacements will be processed within 5 business days.

All returns must be shipped back to the Best Choice Products Return Center at the customer's expense. If the reason for return is a result of an error by Best Choice Products then Best Choice Products will provide a pre-paid shipping label via email. Boxes for return shipping will not be provided by Best Choice Products, and is the customer's responsibility to either use the original shipping boxes or purchase new boxes.

Pictures may be required for some returns to ensure an item is not damaged prior to its return. Items returned are not considered undamaged until they are received by Best Choice Products and verified as such. All damages to items are the customer's responsibility until the item has been received by and acknowledge by Best Choice Products as undamaged.



WARNING

Manufacturer and seller expressly disclaim any and all liability for personal injury, property damage or loss, whether direct, indirect, or incidental, resulting from the incorrect attachment, improper use, inadequate maintenance, unapproved modification, or neglect of this product.