

BLACK◆DIAMOND®

Project Name: _____

Location: _____

Item #: _____

Qty: _____

Black Diamond 36" Gas Range with Oven, 6 Burners, in Stainless Steel

BDGR-36-LPG



Optimize your kitchen's efficiency with this high-performance Black Diamond Gas Range, crafted for demanding culinary environments. Built with robust stainless steel and cast iron, it promises durability and reliability. This range features six burners, each contributing to a total output of 210,000 BTUs, perfect for high-demand cooking. It operates within a temperature range of 250° to 550°F, offering versatility. Manual ignition and control ensure precision, while maintenance is simplified with removable grids and a drip tray.

FEATURES AND CONSTRUCTION

- Crafted from stainless steel and cast iron for durability
- Powered by 210,000 BTUs for robust cooking performance
- Equipped with 6 burners for versatile cooking
- Features a spacious 36-inch design
- Includes four adjustable legs for stability
- Comes with a coupling adaptor and gas connection for liquid propane
- Manual ignition and control type for easy use
- Maintains temperatures from 250° to 550°F
- Drip tray included for easy cleaning

3RD PARTY APPROVALS



Intertek



Intertek

WARRANTY (USA / CANADA)

Protected by Admiral Craft Equipment Corporation's one-year limited warranty.

Contact Admiral Craft Equipment for details at 1-877-672-7740



INCLUDED COMPONENTS

- (1) Relief Valve
- (7) Gas Conversion Orifices
- (1) Gas Conversion Pilot Orifice
- (1) Rear Backplate Assembly
- (19) Screws
- (4) Casters

BLACK DIAMOND® Black Diamond 36" Gas Range with Oven, 6 Burners, LPG

BDGR-36-LPG

FRONT

SIDE

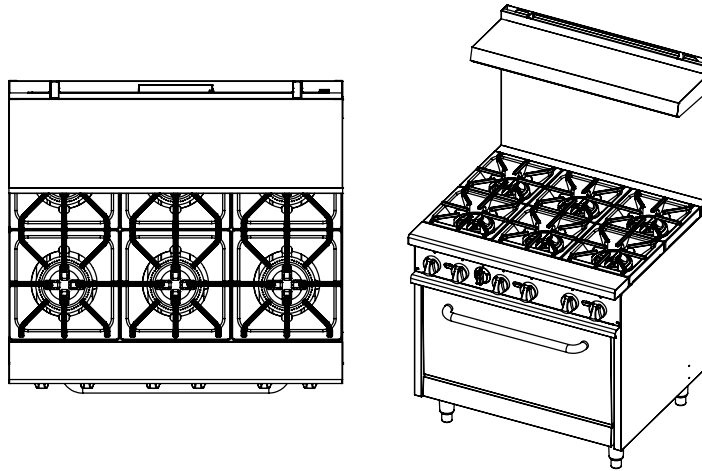
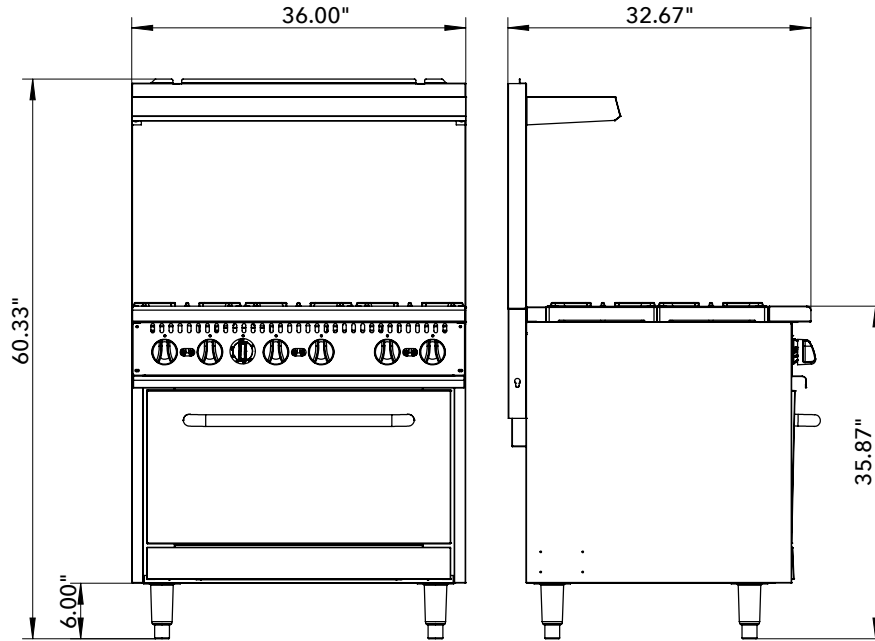

TOP

Gas

Total BTU/hr	Number of Burners	Number of Ovens	Crumb Trays	Assembled Dimensions (in)	Item Weight (lbs)	Shipping Weight (lbs)
210000	6	1	1	32.67" x 36" x 60.33"	377.0	449.8

ADDITIONAL INFORMATION

- Electricity not needed.
- Liquid Propane (LP) or Natural Gas (NG) units available. Field convertible from LP to NG and vice versa.
- Minimum supply pressure is 4" W.C. for natural gas and 10" W.C. for propane.
- Gas powered appliances must always be indoors, under an approved exhaust system with grease removal filters and a fire protection system.

Due to periodic changes in designs, methods, procedures, policies and regulations, the specifications contained in this document are subject to change without notice. While we exercise good faith efforts to provide information that is accurate, we are not responsible for errors or omissions in information provided or conclusions reached as a result of using the specifications. By using the information provided, the user assumes all risks in connection with such use.