

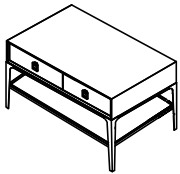



HEKMAN®

X A HOWARD MILLER COMPANY

23801 RECT. COFFEE TABLE

Hardware List

A	B	C	D	
ALLEN BOLT M6 X 20 (12 PCS.)	FLAT W. M6 12 PCS.	SPRING W. M6 12 PCS.	ALLEN KEY L4 (FOR ALLEN BOLT) 1 PC.	
				

Assembly Instruction

STEP 1.

LAY BODY RECT. COFFEE TABLE UPSIDE DOWN ON A SOFT, CLEAN AND FLAT SURFACE. ALIGN LEGS (3 PCS) TO HOLES ON CORNER AND CONNECT USING PLAIN WASHER (B), SPRING WASHER (C), ALLEN BOLT (A) AND ALLEN KEY (D) PROVIDED.

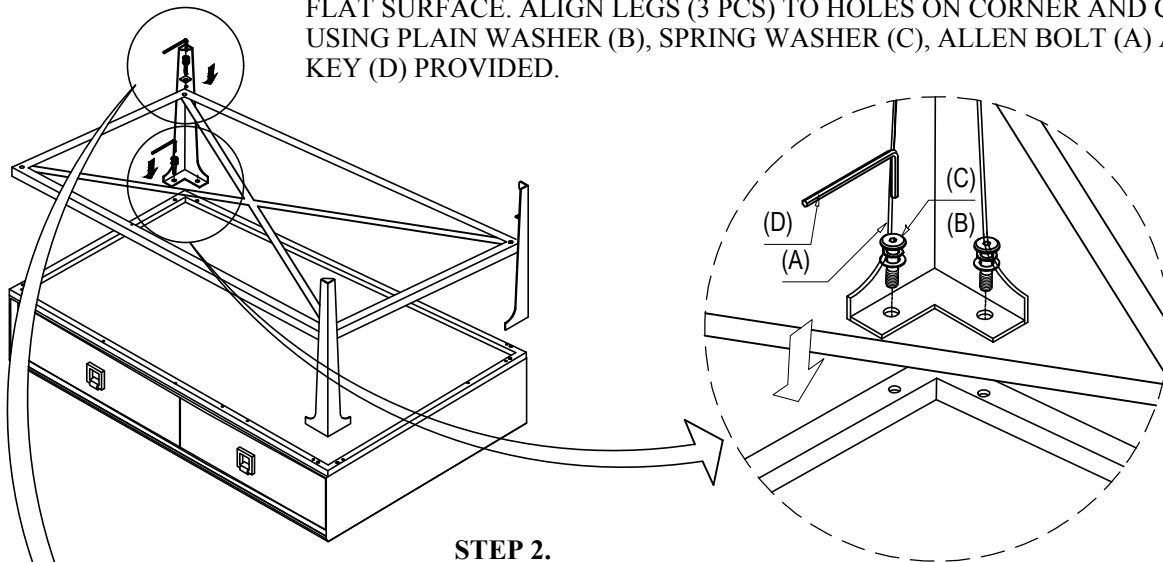

STEP 2.

ALIGN LEGS (3 PCS) TO HOLES ON CORNER AND CONNECT MIDDLE AND BOTTOM SHELF USING PLAIN WASHER (B), SPRING WASHER (C), ALLEN BOLT (A) AND ALLEN KEY (D) PROVIDED. ENSURE TIGHTEN ALL.

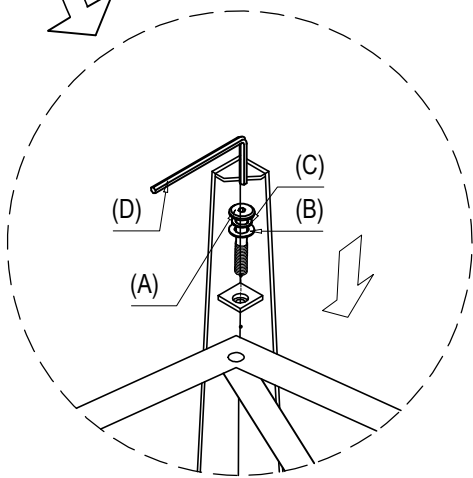

STEP 3

PLACE THE GLASS ON SHELF BOTTOM LEGS.

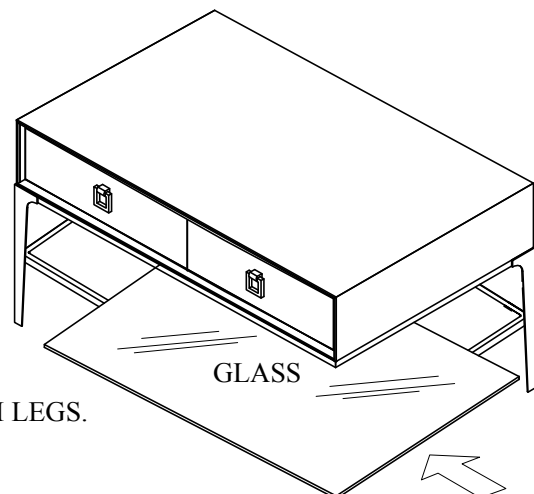

STEP 4.

ALIGN LEGS (1 PC) TO HOLES ON CORNER AND CONNECT MIDDLE AND BOTTOM SHELF USING PLAIN WASHER (B), SPRING WASHER (C), ALLEN BOLT (A) AND ALLEN KEY (D) PROVIDED. TIGHTEN ALL.

