

WWT
WESTINTRENDS
WWT

DESIGNED IN CALIFORNIA

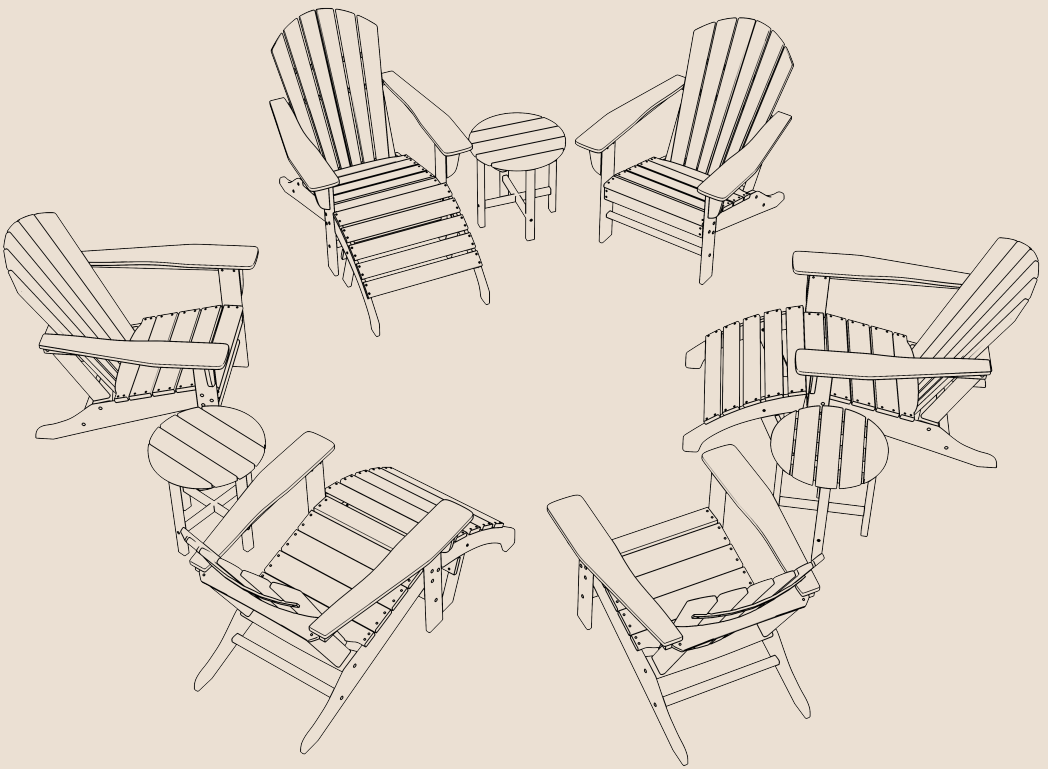

12 PIECE OUTDOOR ADIRONDACK
CHAIR WITH OTTOMAN
AND SIDE TABLE

THANK YOU!

We appreciate you for choosing WestinTrends!

Thank you for letting WestinTrends continue to offer accessible luxury trends, inspired by everyone!

JOIN THE WESTINTRENDS COMMUNITY

Sign up here:

[*https://westintrends.com/welcome*](https://westintrends.com/welcome)



QUESTIONS OR COMMENTS?

If you have questions reach out to
cs@westintrends.com

FOLLOW, SHARE, & LEARN



PRODUCT REGISTRATION

[*https://westintrends.com/apps/product-registration*](https://westintrends.com/apps/product-registration)



TABLE OF CONTENTS

ASSEMBLY INSTRUCTIONS

Altura Outdoor Adirondack Chair.....	4
Round 18" Side Table	9

W/T
WESTINTRENDS
W/T

DESIGNED IN CALIFORNIA

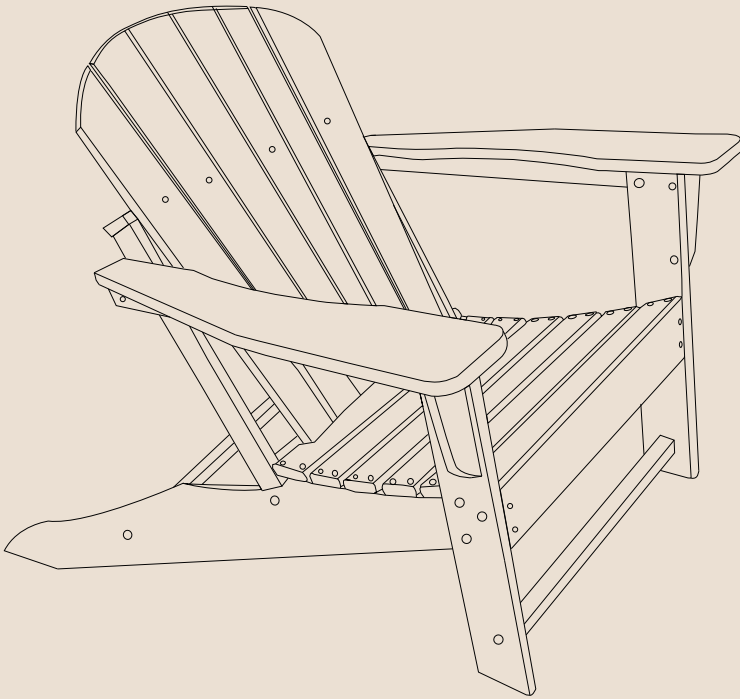

— ALTURA OUTDOOR ADIRONDACK CHAIR —

! CARE & MAINTENANCE

Do not overtighten bolts. (Insert all bolts before tightening bolts.)

- Please do not exceed the weight limitations of this item.
- Do not stand on or use any part of this item as a step ladder.
- Firmly secure all bolts, screws and nuts before use.
- Reconfirm that all bolts, screws, and nuts are secure every 90 days.
- Do not use or store this item in the proximity of open flame or flammable/combustible chemicals.
- Be aware that some parts are heavy and have sharp edges.

TOOLS REQUIRED

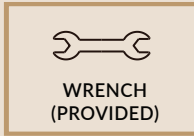

CHAIR
330 LBS
CAPACITY



1 PERSON
ASSEMBLY



UP TO 30 MIN.
ASSEMBLY

HARDWARE

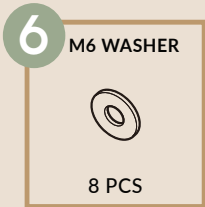
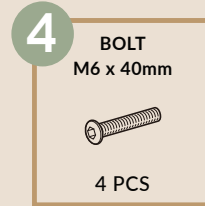
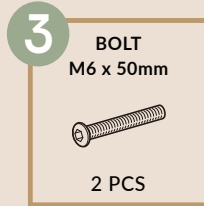
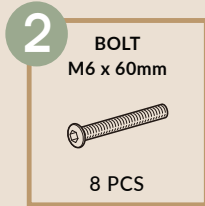
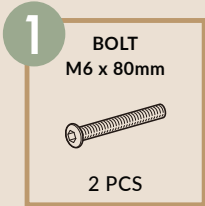

PARTS

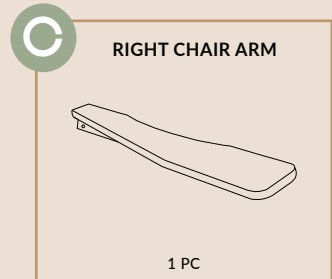
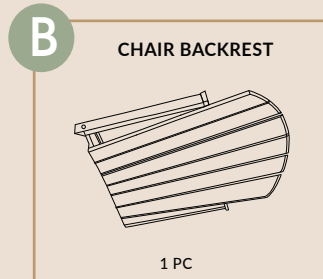
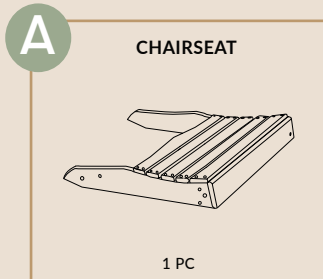

PARTS

D

LEFT CHAIR ARM



1 PC

E

RIGHT CHAIR LEG

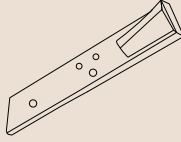

1 PC

F

LEFT CHAIR LEG

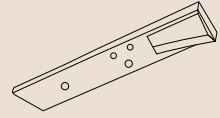

1 PC

G

BACK RAIL



1 PC

H

FRONT RAIL

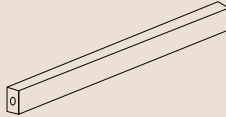

1 PC

PRODUCT ASSEMBLY - OVERALL VIEW

Look at following overall view of this chair and learn the exact position of each part to be assembled.

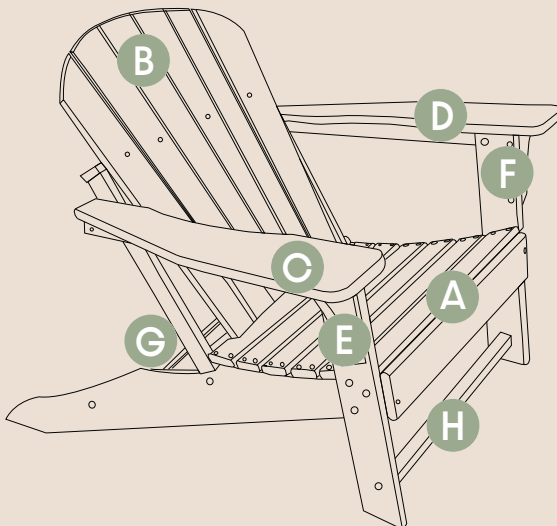

PRODUCT ASSEMBLY

1

Attach **Part F Left Chair Leg** to **Part A Chair Seat** with 3 pcs of **Hardware #2 Bolt**, **Hardware #6 Washer** and **Hardware #5 Nut**. Do the same to **Part E Right Chair Leg** and **Part A Chair Seat**.

Attach **Part H Front Rail** to two chair legs with 2 pcs of **Hardware #4 Bolt**.

Do not tighten bolts too much at this stage.

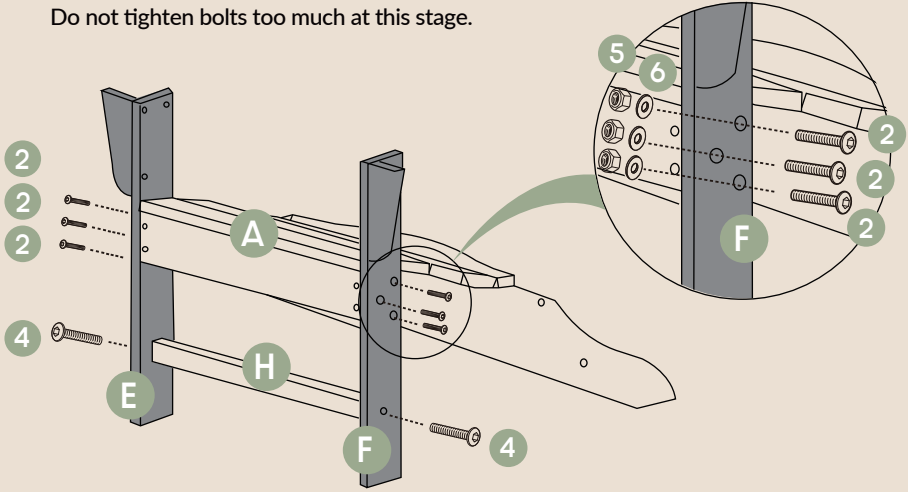

2

Attach **Part C Right Chair Arm** to **Part E Right Chair Leg** with 1pc of **Hardware #2 Bolt**, **Hardware #6 Washer** and **Hardware #5 Nut**.

Do the same to attach **Part D Left Chair Arm** to **Part F Left Chair Leg**.

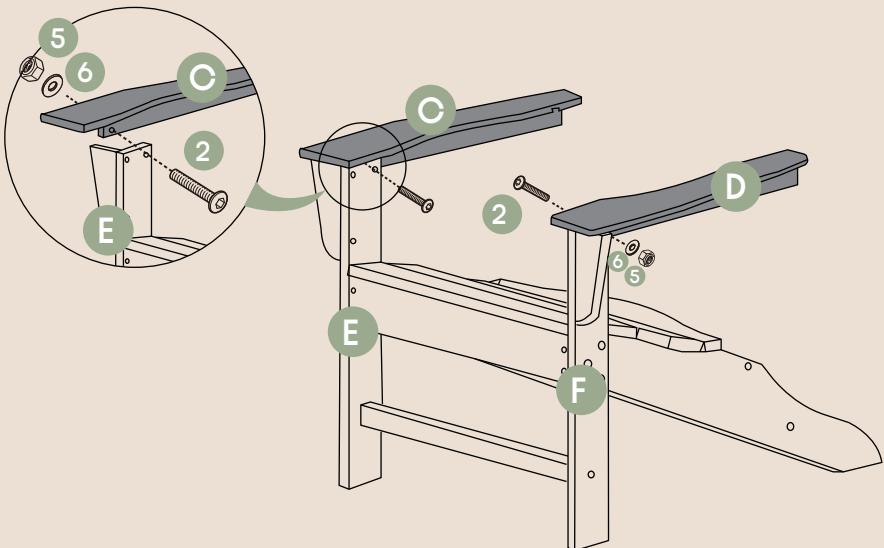

PRODUCT ASSEMBLY

3

Attach **Part B Chair Backrest** to **Part C Right Chair Arm** and **Part D Left Chair Arm** with 2 pcs of **Hardware #1 Bolt**.

Attach **Part B Chair Backrest** to **Part A Chair Seat** with 2 pcs of **Hardware #3 Bolt**.

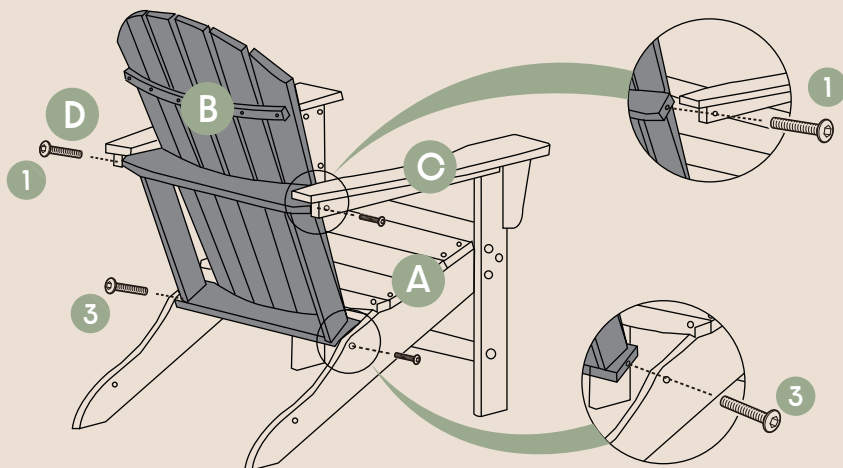

4

Attach **Part G Back Rail** between rear legs of **Part A Chair Seat** with 2 pcs of **Hardware #4 Bolt**.

Check and tighten all the bolts and screws again to finish the assembly.

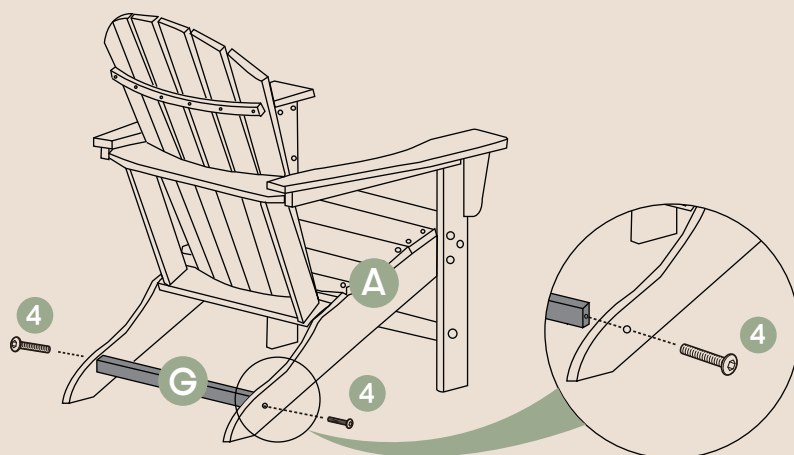



DESIGNED IN CALIFORNIA

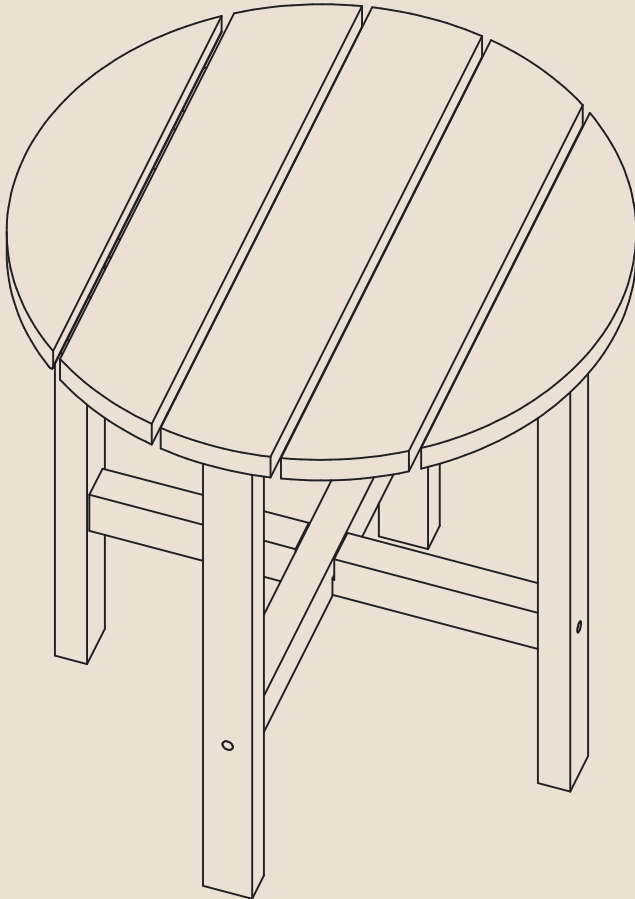

ROUND 18" SIDE TABLE

! NOTICE

Do not overtighten bolts. (Insert all bolts before tightening bolts.)

- Please do not exceed the weight limitations of this item.
- Do not stand on or use any part of this item as a step ladder.
- Firmly secure all bolts, screws and nuts before use.
- Reconfirm that all bolts, screws, and nuts are secure every 90 days.
- Do not use or store this item in the proximity of open flame or flammable/combustible chemicals.
- Be aware that some parts are heavy and have sharp edges.

TOOLS REQUIRED



TABLE
180 LBS
CAPACITY



1 PERSON
ASSEMBLY



UP TO 15 MIN.
ASSEMBLY

HARDWARE

1

BOLT
M6 x 40mm



8 PCS

2

ALLEN
WRENCH



1 PC

PARTS

A

TABLE TOP

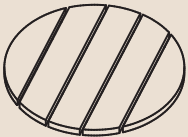

1 PC

B

TABLE LEG

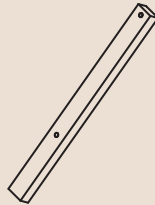

4 PCS

C

CROSS FEET

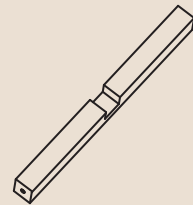

2 PCS

PRODUCT ASSEMBLY - OVERALL VIEW

Look at following overall view of this table and learn the exact position of each part to be assembled.

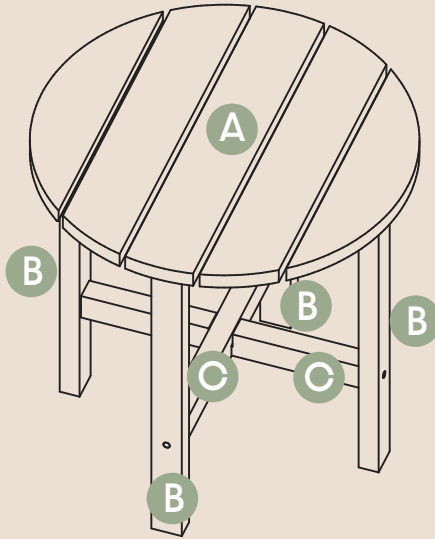

PRODUCT ASSEMBLY

1

Attach **Part C Cross Feet** to 2 pcs of **Part B Table Leg** with 2 pcs of **Hardware #1 Bolt** as shown below.

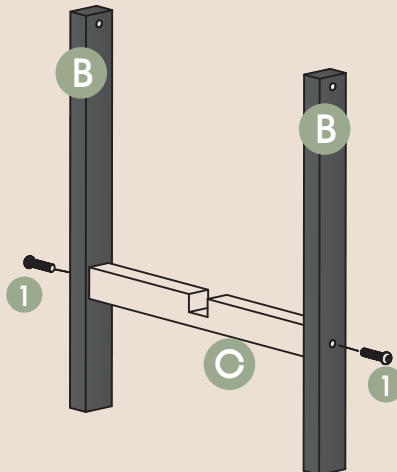

PRODUCT ASSEMBLY

2

Attach **Part C Cross Feet** to 2 pcs of **Part B Table Leg** with 2 pcs of **Hardware #1 Bolt** as shown below.

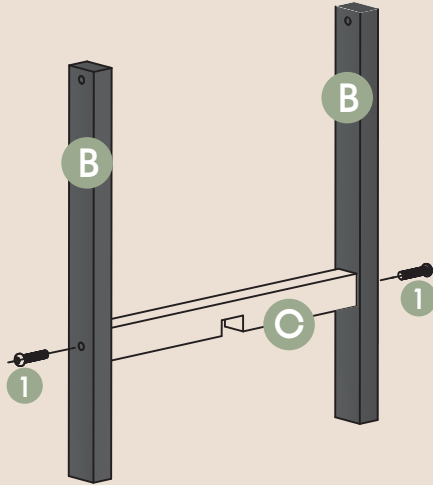

3

Cross the parts from step 1 and step 2, then attach 4 pcs of **Part B Table Leg** to **Part A Table Top** with 4 pcs of **Hardware #1 Bolt**.

Check and tighten all the bolts and screws again to finish the assembly.

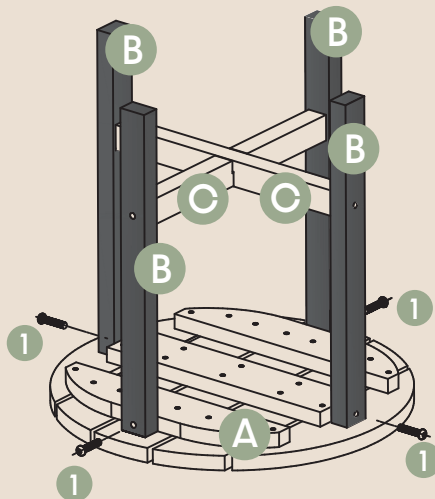

REGISTRATION & REFUND POLICY

<https://westintrends.com/apps/product-registration>



<https://westintrends.com/policies/refund-policy>



HAVING TROUBLE

- **Not sure how to assemble or missing pieces?**

Please contact our Customer Service Team for assistance at cs@westintrends.com

Have Order #, Part # or SKU ready to speed up customer service!

CLEANING TIPS

REGULAR CLEAN: Use a mixture of warm water and mild soap. Gently scrub the surface with a soft bristle brush to remove any dirt or stains.

QUICK CLEAN: You can simply wipe down the HDPE furniture with a damp cloth. The material's resilience makes it resistant to most spills and stains, ensuring a hassle-free maintenance routine.

Regular cleaning not only preserves the aesthetic appeal of your furniture but also helps extend its lifespan.

Pressure washer can be used for seriously deep-cleaning - **DO NOT exceed 1500 PSI** - this will remove any debris and dirt.