

# Product Specifications

## 4.25-Gallon Square Container with EZ Cover®

### Multiple Uses

Dry Products

### Product Codes

Container: **S427**

Description: 4.25-gallon square can

Cover: **STDR**

Description: Tamper-evident, square EZ Cover® with Ring Pull™

### Features

Built in hand grips

Gauge: 65 mil.

Nominal capacity: 4.25 USG / 16.0 L

Stack performance: 175 lbs.\*

Tare weights: Body: 1.50 lbs. / .68 kgs.

Cover: .37 lbs. / .17 kgs.

Note: \*Ratings will be reduced with uneven load distribution.

### Specifications with Cover

Dimensions: 9-15/16" X 9-15/16" X 14-3/4"H

Maximum capacity: 4.4 USG / 16.6 L

Tare weight: 1.87 lbs. / .85 kgs.

### Colors

Standard: White, Black and Natural

Custom: Available at manufacturer's discretion

### Decorating Options

Silk - Screening 5"W X 8-1/2"H

Four or six\* color offset printing

Print area: 5"W X 8-1/2"H on each panel

Sleeve or pressure sensitive labeling

Note: \*Where available

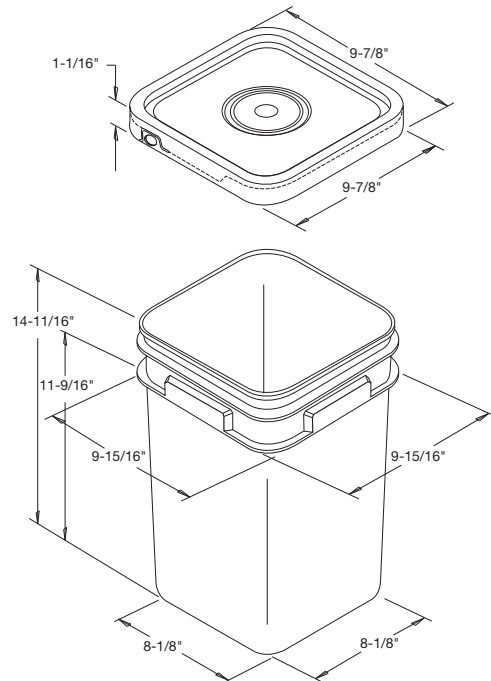

### Shipping Data

Qty. per pallet:

Gross Weight (lbs./kgs)\*\*:

Den. (lbs./C.F./kgs./m3):

Length (in./cm.):

Width (in./cm.):

Height (in./cm.):

Estimated truckload quantity of 11,040 bodies and covers\*\*\*

### Bodies

240

360/163.2

6.0/96.5

51.2/130

42/106.7

48/121.9

### Covers

2,304 (24 boxes of 96)\*

852.5/391.7

8.0/129.9

51/129.5

41/104.1

89/223.6

### Filled Containers

60 (20 per layer / 3 layers high)

Pallet height: 48.7"

Notes: \*Bulk pack also available

\*\*Weight does not include pallet/packaging

\*\*\*Truckload quantity based on 53' trailer

### Materials

FDA approved materials

Resin: Body: High-Density Polyethylene (HDPE)  
or Clear Polypropylene (PP)

Cover: High-Density Polyethylene (HDPE)

MSDS Sheets available upon request

### Optional Carrying Handle

### DISCLAIMER

THIS INFORMATION IS PROVIDED AS A GENERAL GUIDE, INCLUDING DIMENSIONS. IT IS THE CUSTOMER'S RESPONSIBILITIES TO SELECT THE PROPER CONTAINER FOR PRODUCT AND APPLICATION COMPATIBILITY.

DISTRIBUTED BY:



REF NO.:

DWG30564

DESCRIPTION:

HDPE EZ Stor Tear Tab Cover for 2 -  
4.25 Gallon Pails (No Gasket)