

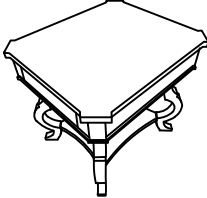







HEKMAN®

X A HOWARD MILLER COMPANY

24603 SINGLE DRAWER LAMP TABLE

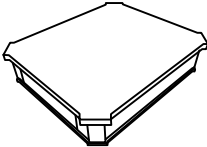
HARDWARE LIST					
A	B	C	D	E	
ALLEN BOLT M6 x 40 (8 Pcs)	FLAT W. M6 (8 Pcs)	LOCK W. M8 (8 Pcs)	SCREW Ø6 x 3/4" (4 Pcs)	ALLEN KEY L4 (FOR BOLT M6) 1 Pc	
					

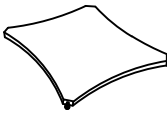
PART INSIDE			
1	2	3	4
TOP ASSEMBLY (1 Pc)	LEGS A (2 Pcs)	LEGS B (2 Pcs)	SHELF (1 Pc)
			

Assembly Instruction

STEP 1.

LAY TOP ASSEMBLY UPSIDE DOWN ON A SOFT, CLEAN AND FLAT SURFACE. ALIGN LEGS TO HOLES ON CORNER AND CONNECT USING FLAT WASHER (B), LOCK WASHER (C), ALLEN BOLT (A) AND ALLEN KEY (E) PROVIDED.

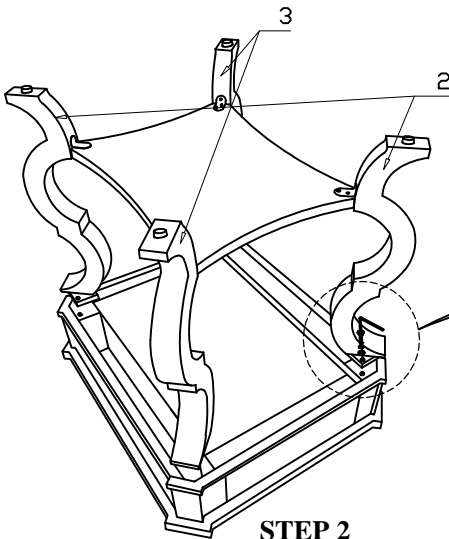

STEP 2

ALIGN AND FASTEN SHELF TO LEGS USING SCREW (D) AND TIGHTEN WITH SCREW DRIVER (NOT INCLUDED).

