

# BLACK DIAMOND®

Project Name: \_\_\_\_\_

Location: \_\_\_\_\_

Item #: \_\_\_\_\_

Qty: \_\_\_\_\_

## Black Diamond Undercounter Freezer, 2 Solid Doors, 11.9 Cu. Ft. Capacity, in Stainless Steel

### GRUCFZ-48



Delivering exceptional value and reliability, this Black Diamond Undercounter Freezer is ideal for commercial kitchens requiring compact frozen storage. Constructed with a stainless steel exterior and painted aluminum interior, it ensures durability and ease of cleaning. With a spacious 11.9 cubic feet capacity, it accommodates a variety of frozen foods. It maintains a temperature range of -8° to 0°F, featuring a fully automatic controller for precise management. The double solid doors enhance energy efficiency and accessibility, while the R290 refrigerant supports eco-friendly operation. Simplified maintenance with automatic defrost and removable door gaskets.

### FEATURES AND CONSTRUCTION

- Offers 11.9 Cu. Ft. of storage capacity for frozen foods and ingredients
- Equipped with a 0.5 horsepower compressor for efficient cooling
- Constructed with durable stainless steel for longevity and easy cleaning
- Maintains a temperature range of -8° to 0°F for optimal food preservation
- Utilizes R290 refrigerant for an eco-friendly operation
- Operates on 115V with a NEMA-5-15P plug for convenience
- Includes two adjustable wire shelves for versatile storage options
- Equipped with four casters for easy mobility and positioning
- Features a user-friendly automatic controller for precise temperature
- Stainless steel doors enhance durability and ease of cleaning

### ELECTRIC

115VV / 60Hz / 1Ph

Cord Length (Inches): 98.40"

Plug Type: NEMA 5-15P

Cord set included

NEMA 5-15P



### 3RD PARTY APPROVALS



### WARRANTY (USA / CANADA)

Two (2) Year Limited Warranty on Parts and Labor, Five (5) Year Warranty on Compressor and Evaporator

Contact us for details at 1.877.368.2797



### STORAGE CAPACITY

- Cubic Feet: 11.9 cu. ft.

### TEMPERATURE

- Holding Temperature (Fahrenheit): -8° - 0°

These models are designed to operate in an environment where temperature and humidity do not exceed 75°F (24°C) and 55% relative humidity



# Black Diamond 2 Door Undercounter Freezer

GRUCFZ-48

FRONT

SIDE

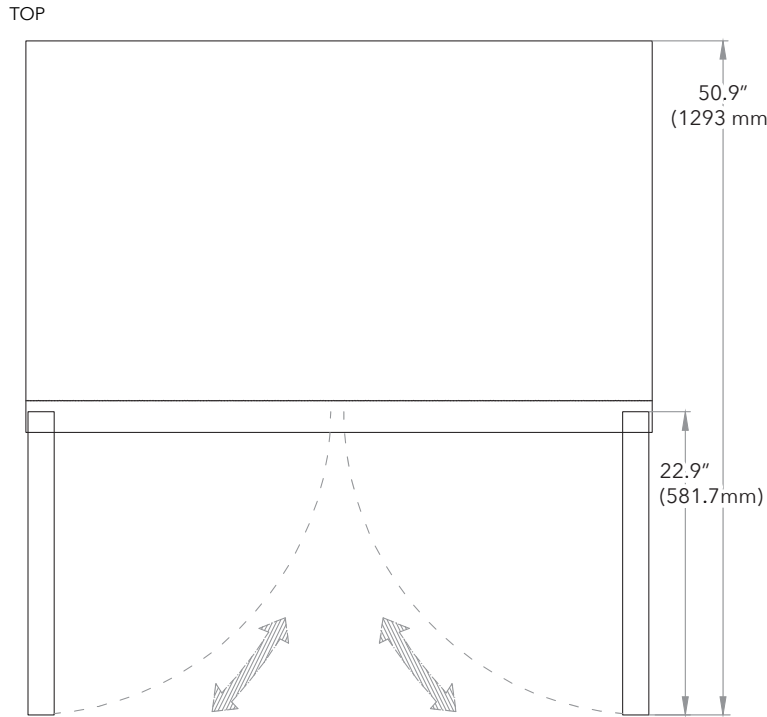
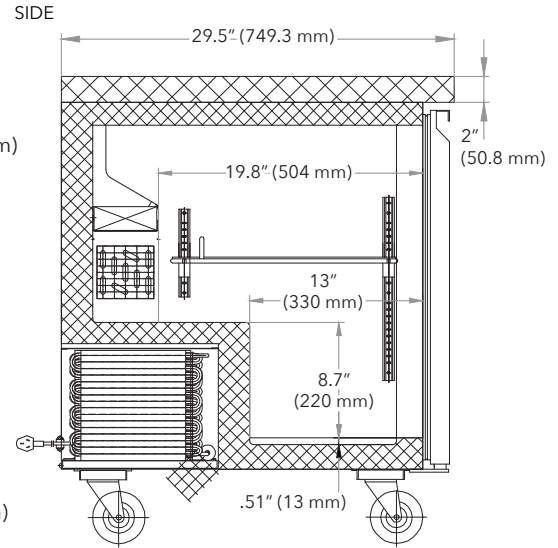
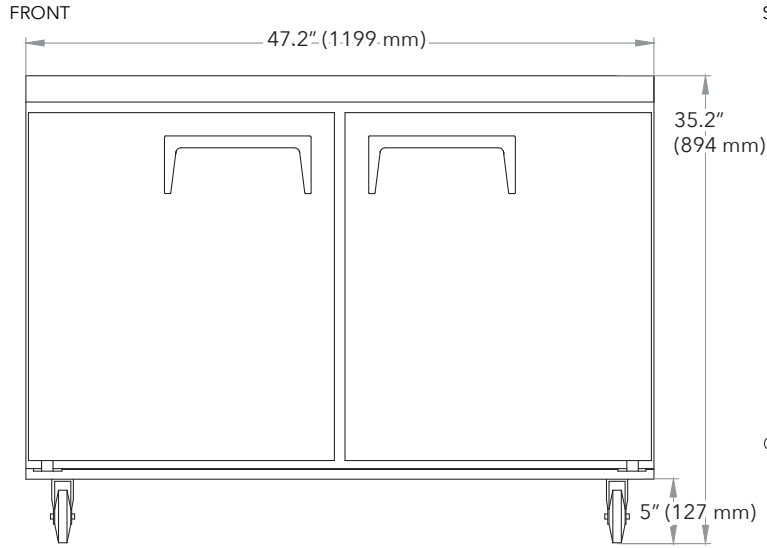

TOP

## Undercounter

Doors	Shelves	Amps	HP	Refrigerant	Assembled Dimensions (in)	Item Weight (lbs)	Shipping Weight (lbs)
2	2	4.5A	1/5	R290	29.50" x 47.20" x 35.20"	213.9	290.0

Due to periodic changes in designs, methods, procedures, policies and regulations, the specifications contained in this document are subject to change without notice. While we exercise good faith efforts to provide information that is accurate, we are not responsible for errors or omissions in information provided or conclusions reached as a result of using the specifications. By using the information provided, the user assumes all risks in connection with such use.