

BLACK DIAMOND®

Project Name: _____

Location: _____

Item #: _____

Qty: _____

Black Diamond Full-Height Proofing and Holding Cabinet, 36 Pan Capacity, in Silver

BDPW36F



The Black Diamond full-height proofing and holding cabinet is designed to deliver consistent proofing and reliable hot holding for bakeries, restaurants, and foodservice operations. With a capacity of 36 standard 18" x 26" sheet pans, this freestanding unit features durable aluminum and PC construction for long life and easy cleaning. User-friendly knob controls, dual temperature and humidity settings, and efficient heating technology enable precise product management and optimal results. Equipped with 5" heavy-duty casters and protective corner bumpers, the cabinet is easy to maneuver in busy kitchens. This unit is covered by a manufacturer's warranty, ensuring dependable service and operational peace of mind.

FEATURES AND CONSTRUCTION

- Constructed of heavy-duty aluminum and polycarbonate for durability and easy cleaning
- Energy-efficient 1440-watt electric heating system delivers rapid and consistent proofing and holding performance
- Accommodates 36 full-size 18" x 26" sheet pans for maximum capacity
- User-friendly knob controls allow straightforward operation and precise adjustments
- Operates with a standard NEMA 5-15 plug on single-phase 120V electric power
- Freestanding design enables flexible placement and easy mobility in any commercial kitchen
- Simple knob-operated controls with dual temperature and humidity settings support various recipes
- Temperature range from 86°F to 203°F for consistent food holding and proofing
- Cabinet measures 67.7"H x 23"W x 33"D for full-size kitchen integration

ELECTRIC

120V / 60Hz / 1Ph

Cord Length (Inches): 78.70

Plug Type: NEMA 5-15

Cord set included

NEMA 5-15P



3RD PARTY APPROVALS



WARRANTY (USA / CANADA)

One (1) Year Limited Warranty on Parts and Labor

Contact us for details at 1.877.368.2797



TEMPERATURE

- Temperature Range (Fahrenheit): 86 - 203

INCLUDED COMPONENTS

- Corner bumpers, 5" casters



Black Diamond Warming Full-Height Proofing and Holding Cabinet

BDPW36F

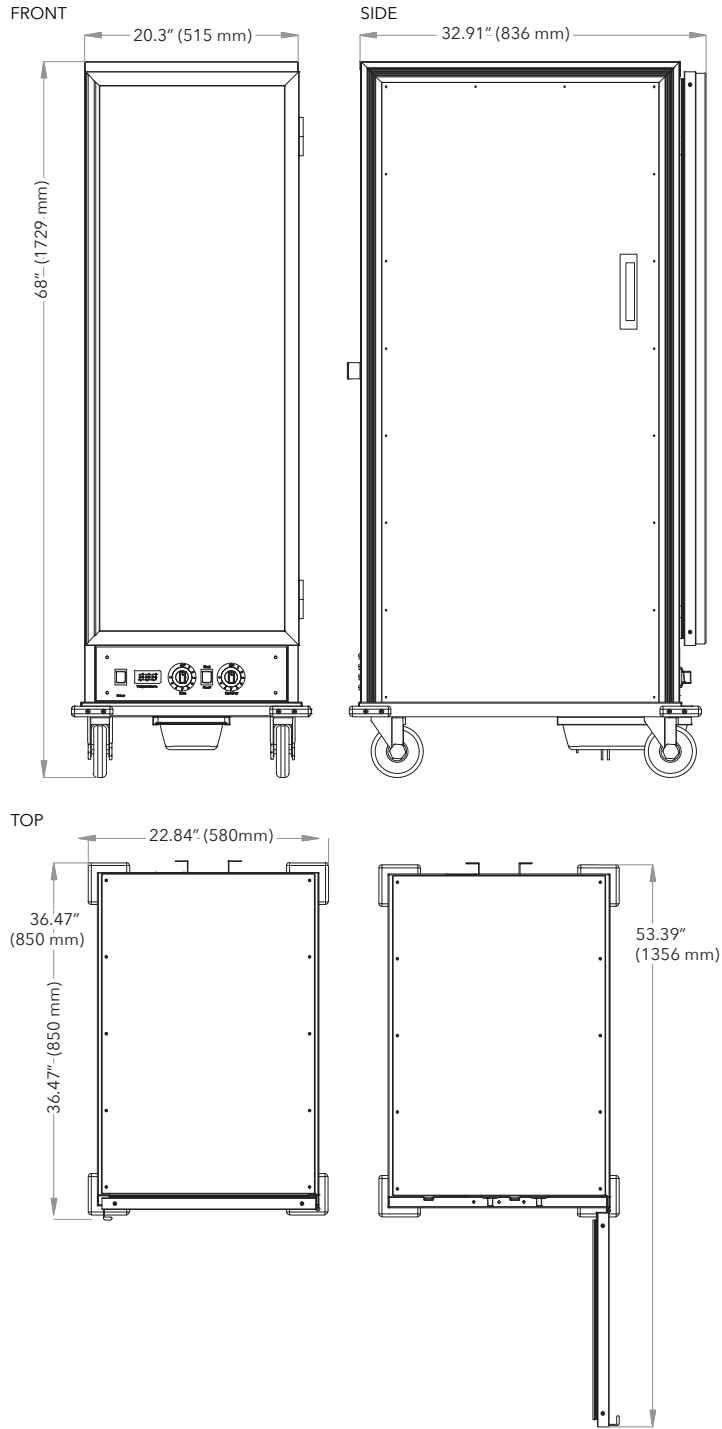

Proofer

Control Type	Amps	Wattage	Shelves	Capacity	Assembled Dimensions L x W x H (in)	Item Weight (lb)	Shipping Weight (lb)
Knob	12	1440	36	15.18 Cu. Ft. (36) Full Size, 18" x 26" Sheet Pans	33.00" x 23.00" x 67.70"	154.4	191.7

Due to periodic changes in designs, methods, procedures, policies and regulations, the specifications contained in this document are subject to change without notice. While we exercise good faith efforts to provide information that is accurate, we are not responsible for errors or omissions in information provided or conclusions reached as a result of using the specifications. By using the information provided, the user assumes all risks in connection with such use.