

Model ST-2459 Series Water Closet Installation Instructions

THE RIGHT CHOICE

We thank you for your purchase. Our products are 100% tested but should you have any questions, please contact us by phone or on our web site.



ST-2459

▲ WARNING: Vitreous china can chip or break if the bolts or nuts are over-tightened or if mishandled.

- Check all local plumbing and building codes.
- Check for any damage to the new water closet before installation.

WHAT YOU WILL NEED...

- Sponge
- Putty knife
- Safety glasses
- Measuring tape
- Spud wrench
- Non-wax Gasket
- 10" adjustable wrench
- Large level
- Carrier Mounting hardware

NOTE: Plumbing System Requirements

- ✓ Minimum Flowing Pressure: 25 PSI
- ✓ Minimum Flow Rate: 18 GPM
- ✓ Maximum Static Pressure: 80 PSI

NOTE: All vitreous china dimensions shown in these drawings are nominal. Dimensions can vary within the tolerances established in the governing ASME A112.19.2/CSA B45.1 standard. Please take this into consideration when planning rough-in and plumbing layouts.

RETROFIT INSTALLATIONS

1. REMOVAL OF EXISTING WATER CLOSET

- Turn off the water supply.
- Disconnect the flush valve.
- Sponge out all remaining water from bowl.
- Cut caulk all around existing bowl using utility knife to release bowl from wall surface.
- Remove the existing water closet.
- Using sharp scraper or putty knife, completely remove all remaining caulk from wall surface.
- Dispose of old gasket.

2. CHECK ROUGH-IN DIMENSIONS

- Check rough-in dimensions and install or relocate flush valve and outlet as indicated.
- A carrier unit is recommended to properly install and support the wall hung water closet. Install carrier unit (not included) per instructions provided by the carrier manufacturer.
- Verify carrier studs are level.

3. CLEAN DRAIN

- Clean out waste pipe using hand or power cleaner to be sure pipe is clear.
- Proceed to NEW INSTALLATIONS.

▲ WARNING: Hazardous gases can escape through the waste pipe if new water closet is not installed quickly. A temporary fix: place a large rag in the waste pipe.

NEW INSTALLATIONS

1. INSTALLING GASKET

- Remove the temporary rag (if used) from the waste pipe hole.
- Lay water closet down on padded surface to help protect the vitreous china.
- Apply gasket to bowl outlet. Refer to the gasket manufacturer's instructions for installation. (Note: wax gaskets of any kind are NOT recommended.)

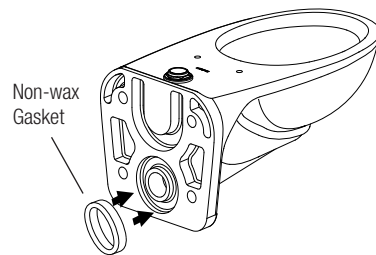

2. INSTALLING WATER CLOSET

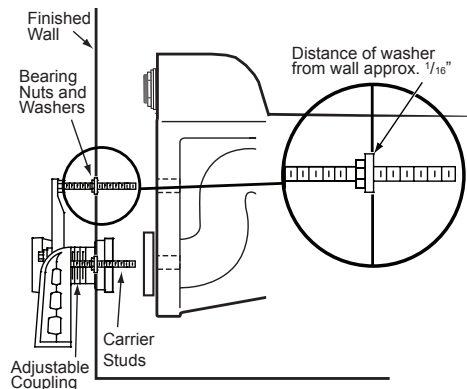

- Determine proper length for carrier studs per carrier's manufacturer.
- Install (3) sets of bearing nuts and washers onto carrier studs: two at the bottom and one on top leaving one top stud blank.
- Bearing nuts and washers must be placed to allow a minimum gap of 1/16" between the wall and fixture. The carrier supports the bowl, not the wall.
- Place level vertically across the top and bottom bearing nuts to ensure they are leveled.
- Adjust carrier coupling to compress gasket for a gas and watertight seal per gasket manufacturer's instructions.

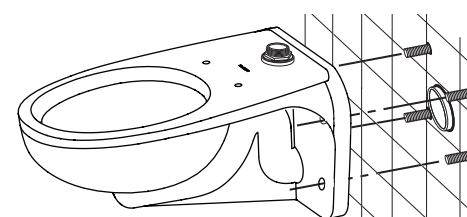

- Place water closet onto the carrier studs.

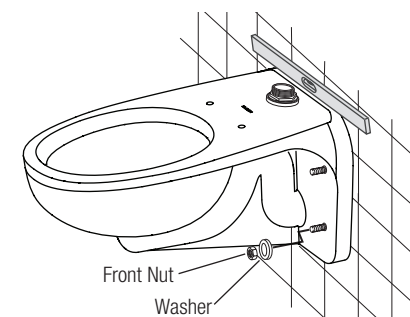

- Loosely attach washers and front nuts on threaded carrier studs.
- Verify water closet is level.
- Hand tighten the (3) nuts that have the bearing nuts behind the water closet.
- Tighten the top nut then bottom nuts alternately while judging the flex of the bowl at the front lip due to the compression of the gasket. Bowl is secure and has adequate seal when no noticeable flex occurs.
- Hand-tighten the last nut and washer, then tighten 1/4-turn using a wrench.

▲ IMPORTANT! Do not overtighten the nuts, breakage and chipping of vitreous china can occur.

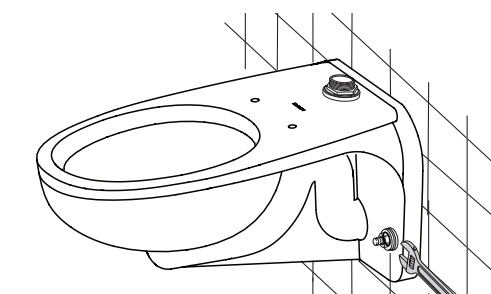

3. COMPLETING THE INSTALLATION

- Flush valve should be installed to manufacturer's installation instructions.

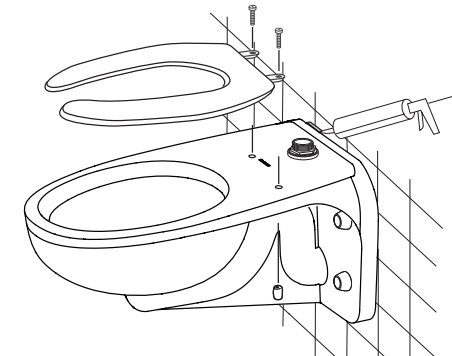

- Turn on water supply valve.
- Install water closet seat.
- Caulk around water closet.
- Flush water closet a few times and check all connections for water seepage.
- Check for leaks for a few days.
- Record model number for reference.

LIMITED WARRANTY

Sloan Valve Company warrants its vitreous china products to be made of first class materials, free from defects of material or workmanship under normal use and to perform the service for which they are intended in a thoroughly reliable and efficient manner when properly installed and serviced, for a period of three years from date of purchase. During this period, Sloan Valve Company will, at its option, repair or replace any part or parts which prove to be thus defective if returned to Sloan Valve Company, at customer's cost, and this shall be the sole remedy available under this warranty. No claims will be allowed for labor, transportation or other incidental costs. This warranty extends only to persons or organizations who purchase Sloan Valve Company's products directly from Sloan Valve Company for purpose of resale.

THERE ARE NO WARRANTIES WHICH EXTEND BEYOND THE DESCRIPTION ON THE FACE HEREOF. IN NO EVENT IS SLOAN VALVE COMPANY RESPONSIBLE FOR ANY CONSEQUENTIAL DAMAGES OF ANY MEASURE WHATSOEVER. NOTE: IN NO EVENT SHALL THE SLOAN VALVE COMPANY BE LIABLE FOR INCIDENTAL DAMAGES, RESULTING FROM IMPROPER INSTALLATION, OR FOR DAMAGES CAUSED BY NEGLIGENCE, ABUSE OR ALTERATION.

TO MAXIMIZE THE PERFORMANCE OF YOUR SLOAN® WATER CLOSET, USE ONLY SLOAN® FLUSHMETERS



SLOAN®

SLOAN VALVE COMPANY

10500 Seymour Avenue
Franklin Park, IL 60131
Phone: 1-800-9-VALVE-9 or 1-847-671-4300
Fax: 1-800-447-8329 or 1-847-671-4380
www.sloanvalve.com

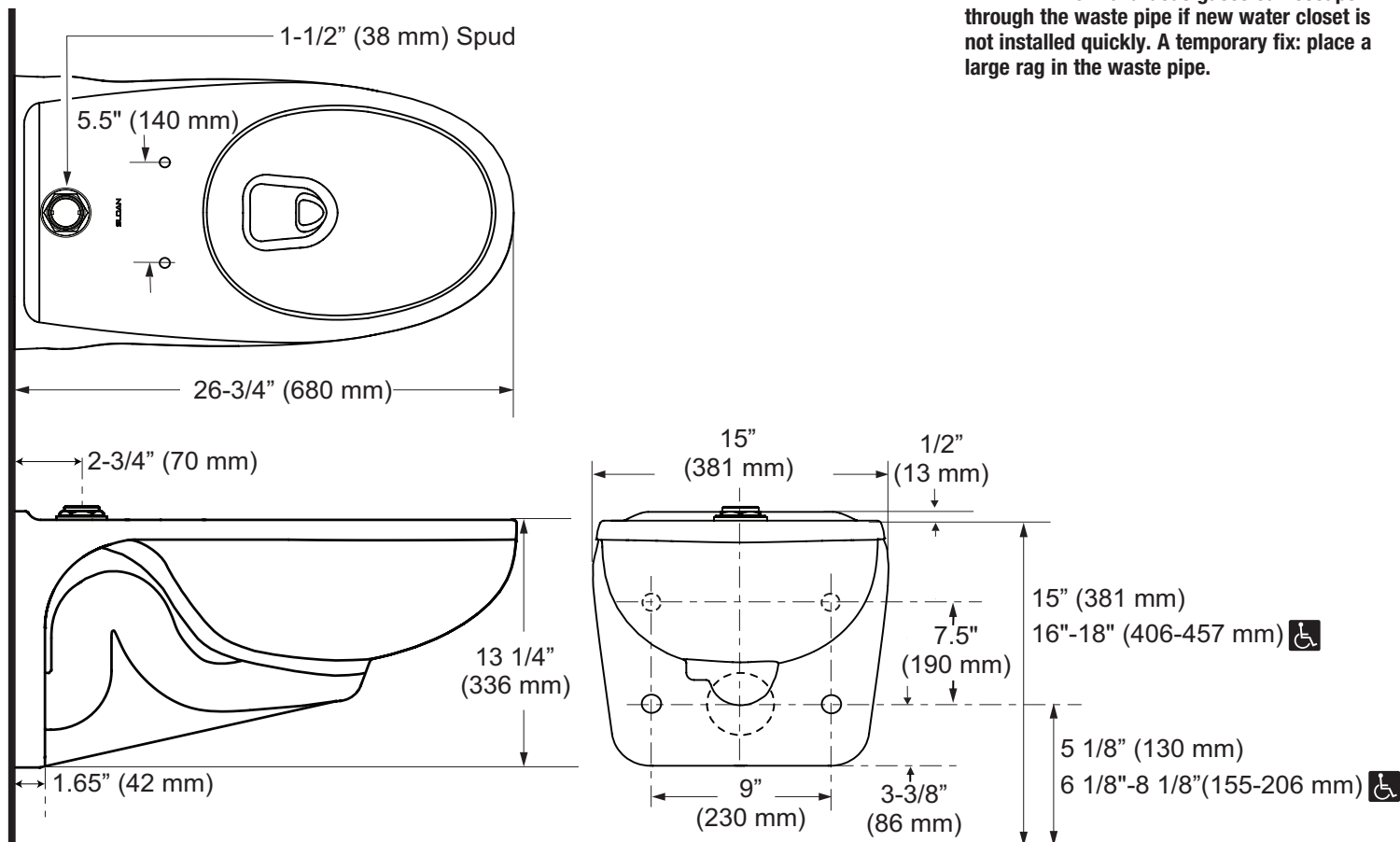

Instalación Instrucciones de Sanitario Modelo Serie ST-2459

LA ELECCIÓN CORRECTA

Le agradecemos su compra. Nuestros productos son probados al 100%, sin embargo, si tiene alguna duda, contáctenos por teléfono o en nuestro sitio web.



ST-2459

⚠ ADVERTENCIA: Cualquier porcelana puede astillarse o romperse si los pernos o tuercas se aprietan de más o si son mal manipulados.

- Revise todos los códigos locales de plomería y construcción.
- Revise si el nuevo sanitario presenta daños antes de instalarlo.

LO QUE USTED NECESITA...

- Espátula para masilla
- Lentes de Seguridad
- Cinta para medir
- Llave para spud
- Empaque sin cera
- Esponja
- Llave ajustable 10"
- Nivel grande
- Cargador y Herrajes de montaje

NOTA: Requerimientos del Sistema de Plomería

✓ Presión Mínima de Flujo: 25 PSI

✓ Caudal Mínimo: 18 GPM

✓ Máxima presión estática: 80 PSI

NOTA: Todas las dimensiones mostradas en estos dibujos son nominales. Las dimensiones pueden variar dentro de las tolerancias establecidas en la norma ASME A112.19.2/CSA B45.1. Por favor tenga esto en cuenta al planificar la preparación y diseños de plomería.

INSTALACIONES DE REEQUIPAMIENTO

1. REMOVER EL SANITARIO EXISTENTE

- Cierre la alimentación de agua.
- Desconecte la válvula de descarga.
- Seque toda el agua remanente en la taza.
- Corte la masilla con el cuchillo multiusos por todo alrededor de la taza existente para soltarla de la superficie.
- Remueva el sanitario existente.
- Usando un raspador afilado o una espátula, remueva completamente la masilla restante de la superficie de la pared.
- Elimine el empaque usado.

2. REVISAR LAS DIMENSIONES DE PREPARACIÓN

- Revise las dimensiones de preparación e instale o mueva la válvula de descarga y salida como se indica
- Se recomienda una unidad portadora para instalar adecuadamente y soportar el sanitario colgado de pared. Instale la unidad portadora (no incluido) de acuerdo con las instrucciones del fabricante de la misma.
- Verifique que los pernos del portador estén nivelados.

3. LIMPIAR EL DESAGÜE

- Limpie el tubo de drenaje con un limpiador manual o eléctrico para asegurarse que quede bien limpio.
- Proceda a INSTALACIONES NUEVAS.

⚠ ADVERTENCIA: Gases peligrosos pueden escapar por la tubería de desague si el nuevo sanitario no se instala rápidamente. Una solución temporal: coloque un trozo grande de tela en la tubería de desague.

INSTALACIONES NUEVAS

1. INSTALAR EL EMPAQUE

- Remueva el trozo de tela temporal (si se utilizó) del agujero del tubo de drenaje.
- Coloque el sanitario sobre una superficie acolchada para proteger la porcelana.
- Coloque el empaque a la salida de la taza. Consulte su instalación en las instrucciones del fabricante del empaque. (Nota: NO se recomiendan los empaques de cualquier tipo que son totalmente de cera).

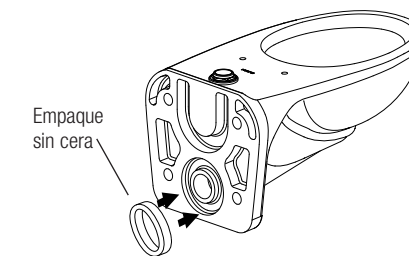

2. INSTALAR EL SANITARIO

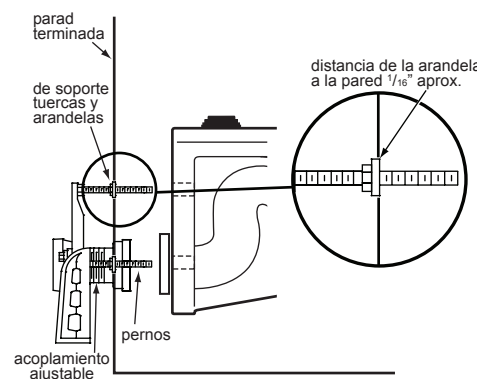

- Determine la longitud necesaria de los pernos de acuerdo a las instrucciones del fabricante del portador.
- Instale (3) juegos de tuercas y arandelas de soporte en los pernos del portador: dos en la parte inferior y en uno de los pernos superiores dejando el otro sin tuerca ni arandela.
- Las tuercas y arandelas de soporte deben ser instaladas garantizando un espacio mínimo de 1.6 mm (1/16") entre el sanitario y la pared. El portador es el que debe soportar el sanitario, no la pared.
- Coloque un nivel sobre las dos tuercas de soporte inferiores y luego sobre la tuerca de soporte superior asegurando que están niveladas.
- Ajuste el acomplamiento del portador para asegurar la adecuada compresión en el empaque para garantizar un buen sello.

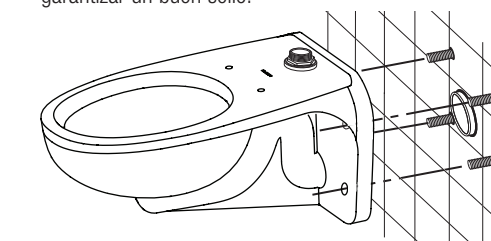

- Coloque el sanitario en los pernos del portador.

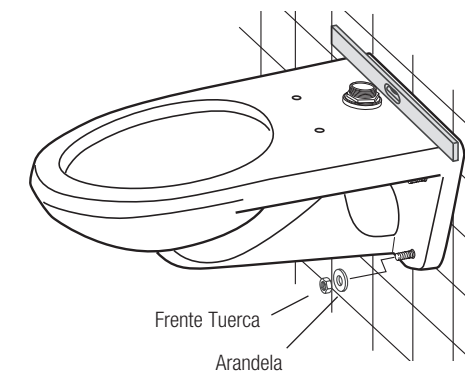

- Coloque flojas las arandelas y tapones roscados en los pernos roscados del portador.
- Verifique que el sanitario esté nivelado.
- Apriete firmemente los (3) tapones roscados y arandelas en los pernos que contienen las tuercas y arandelas de soporte. Luego instale la última arandela y tapón roscado apretando aproximadamente 1/4 de vuelta.

⚠ ¡IMPORTANTE! No apriete de más las tuercas, puede ocurrir ruptura o astillarse la porcelana.

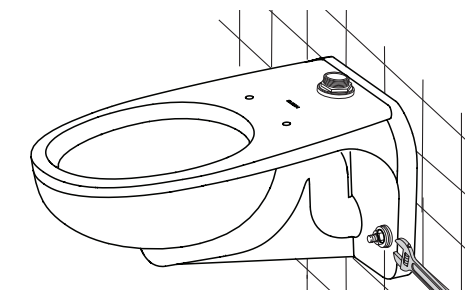

3. TERMINAR LA INSTALACIÓN

- La válvula de descarga debe instalarse de acuerdo con las instrucciones de su fabricante.

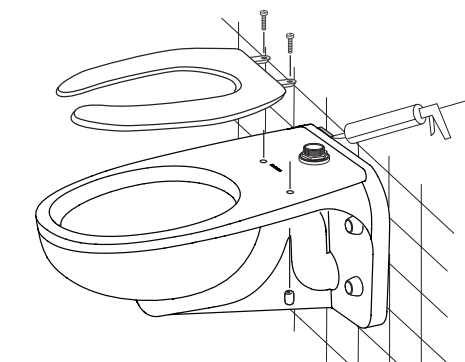

- Abra la válvula de alimentación de agua.
- Instale el asiento del sanitario.
- Coloque masilla alrededor del sanitario.
- Descargue el sanitario varias veces y revise todas las conexiones para ver si presentan filtraciones.
- Revise si hay fugas por varios días.
- Registre el número de modelo como referencia.

GARANTÍA LIMITADA

Sloan Valve Company garantiza que sus productos de porcelana están hechos de materiales de primera clase, libres de defectos en el material o en la fabricación, bajo uso normal y para llevar a cabo el servicio para el cual se han fabricado, en una forma totalmente eficiente y confiable siempre que se instalen adecuadamente y se les dé el servicio adecuado, por un período de tres años a partir de la fecha de compra. Durante este período Sloan, a su discreción, reparará o reemplazará cualquier parte o partes que se comprueben que estén defectuosas si se devuelven a Sloan, a costo del cliente, y este será el único recurso correctivo que se ofrece con esta garantía. No se aceptarán reclamos por mano de obra, transporte u otros costos incidentales. La presente garantía se extiende únicamente a personas u organizaciones que compren los productos de Sloan Valve Company directamente de Sloan Valve Company con fines de reventa.

NO EXISTEN MÁS GARANTÍAS QUE SE EXTIENDAN MAS ALLÁ DE LA QUE SE DESCRIBIÓ ANTERIORMENTE. EN NINGÚN CASO SLOAN VALVE COMPANY ES RESPONSABLE POR CUALQUIER DAÑO CONSECUENTE DE CUALQUIER CLASE.

NOTA: EN NINGÚN CASO SLOAN VALVE COMPANY SERÁ RESPONSABLE POR DAÑOS INCIDENTALES, RESULTADO DE INSTALACIÓN INADECUADA, O POR DAÑOS CAUSADOS POR NEGLIGENCIA, ABUSO O ALTERACIÓN.

PARA MAXIMIZAR EL DESEMPEÑO DE SU SANITARIO SLOAN® USE ÚNICAMENTE FLUXOMETROS SLOAN®



SLOAN®
SLOAN VALVE COMPANY

10500 Seymour Avenue
Franklin Park, IL 60131
Tel: 1-800-9-VALVE-9 o 1-847-671-4300
Fax: 1-800-447-8329 o 1-847-671-4380
www.sloanvalve.com

Copyright © 2015 Sloan Valve Company
No. Código: 0816652 Rev.1 09-15

INSTALLATION INSTRUCTIONS FOR OPTIMA® SYSTEM SENSOR ACTIVATED ROYAL® EXPOSED WITH TRUE MECHANICAL OVERRIDE FLUSHMETERS

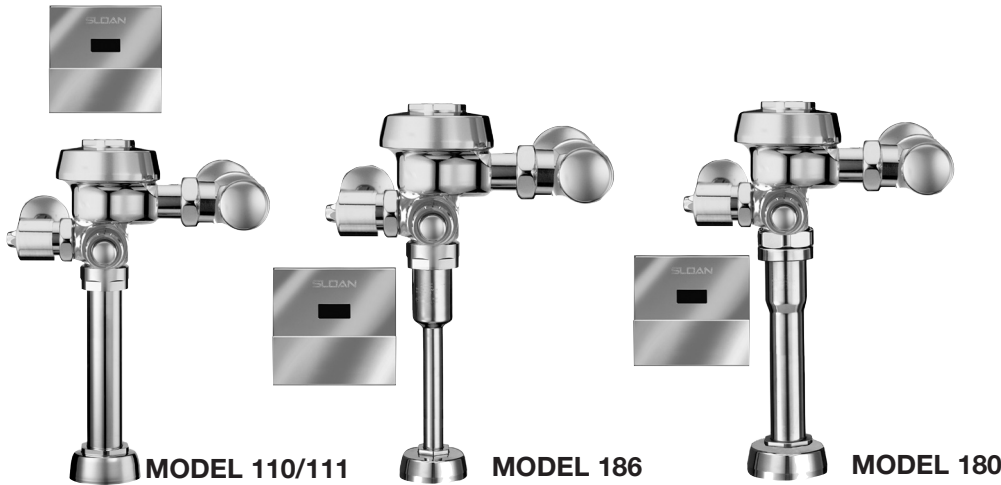

Exposed Closet Flushometers 1-1/2" Top Spud

- Model 110/111 ES-S TMO
- Model 113 ES-S TMO
- Model 115 ES-S TMO
- Model 116 ES-S TMO

Exposed Urinal Flushometers 3/4" Top Spud

- Model 186 ES-S TMO

Exposed Urinal Flushometers 1-1/4" Top Spud

- Model 180 ES-S TMO



LIMITED WARRANTY

Unless otherwise noted, Sloan Valve Company warrants its products, manufactured and sold for commercial or industrial uses, to be free from defects in material and workmanship for a period of three (3) years (one (1) year for special finishes, SF faucets, PWT electronics and 30 days for PWT software) from date of first purchase. During this period, Sloan Valve Company will, at its option, repair, replace, or refund the purchase price of any product which fails to conform with this warranty under normal use and service. This shall be the sole and exclusive remedy under this warranty. Products must be returned to Sloan Valve Company, at customer's cost. No claims will be allowed for labor, transportation or other costs. This warranty extends only to persons or organizations who purchase Sloan Valve Company's products directly from Sloan Valve Company for purpose of resale. This warranty does not cover the life of the batteries.

THERE ARE NO WARRANTIES WHICH EXTEND BEYOND THE DESCRIPTION ON THE FACE HEREOF. IN NO EVENT IS SLOAN VALVE COMPANY RESPONSIBLE FOR ANY CONSEQUENTIAL DAMAGES OF ANY MEASURE WHATSOEVER.

ROUGH-IN

MODEL 110/111/113

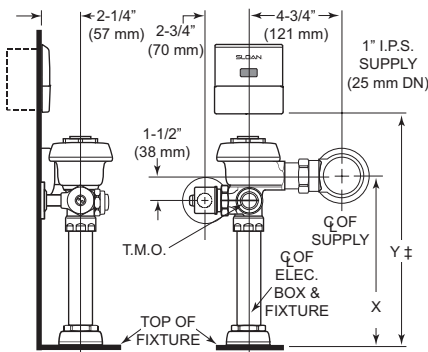

X MODEL 110/111 - 11½" (292 mm) Y MODEL 110/111 - 19" (356 mm)
MODEL 113 - 16" (406 mm) MODEL 113 - 19" (483 mm)

MODEL 186

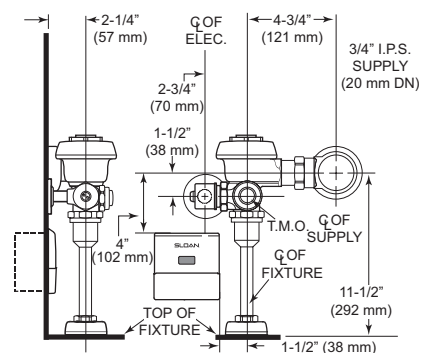

MODEL 180

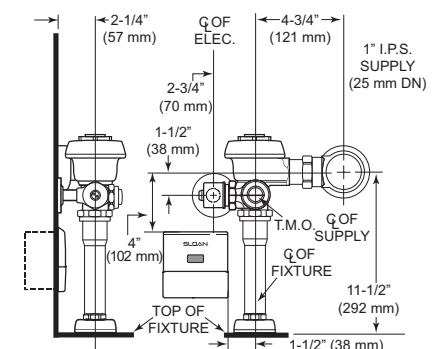

MODEL 115/116

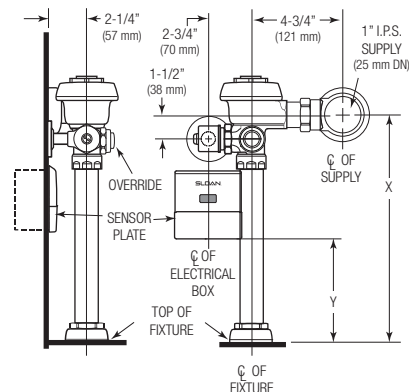

X MODEL 115 - 24" ± (610 mm) Y MODEL 115 - 14" ± (356 mm)
MODEL 116 - 27" ± (686 mm) MODEL 116 - 17" ± (432 mm)

± POSITION OF SENSOR BOX CAN BE RAISED OR LOWERED 1" (25 mm) IF IN CONFLICT WITH HANDICAP GRAB BARS.

PRIOR TO INSTALLATION

Prior to installation, install the items listed below.

- Electrical wiring to the transformer box (120 VAC, 2 amp service required for each EL-154, 24 VAC, 50 VA transformer used)
- Closet fixture
- Water supply line
- Drain line

IMPORTANT:

- **ALL PLUMBING AND ELECTRICAL WIRING SHOULD BE INSTALLED IN ACCORDANCE WITH APPLICABLE CODES AND REGULATIONS.**
- **WATER SUPPLY LINES MUST BE SIZED TO PROVIDE AN ADEQUATE VOLUME OF WATER FOR EACH FIXTURE.**
- **A 24 VAC STEP-DOWN TRANSFORMER MUST BE USED.**
- **WHEN INSTALLING A FLUSHOMETER, IT IS IMPORTANT THAT THE FLUSH MODEL MATCHES THE REQUIREMENTS OF THE PLUMBING FIXTURE.**
- **FLUSH ALL WATER LINES PRIOR TO MAKING CONNECTIONS.**

Sloan flushometers are designed to operate with flowing pressure 15 to 100 psi (104 to 689 kPa) of water pressure. **THE MINIMUM PRESSURE REQUIRED TO THE VALVE IS DETERMINED BY THE TYPE OF FIXTURE SELECTED.**

Consult fixture manufacturer for minimum pressure requirements.

Most Low Consumption water closets (1.6 gpf/6.0 Lpf) require a minimum flowing pressure of 25 psi (172 kPa).

Protect the chrome or special finish of this flushometer — **DO NOT USE TOOTHED TOOLS TO INSTALL OR SERVICE THE VALVE.** Also, see “Care and Cleaning” section of this manual.

IMPORTANT: EXCEPT FOR CONTROL STOP INLET, DO NOT USE PIPE SEALANT OR PLUMBING GREASE ON ANY VALVE COMPONENT OR COUPLING!

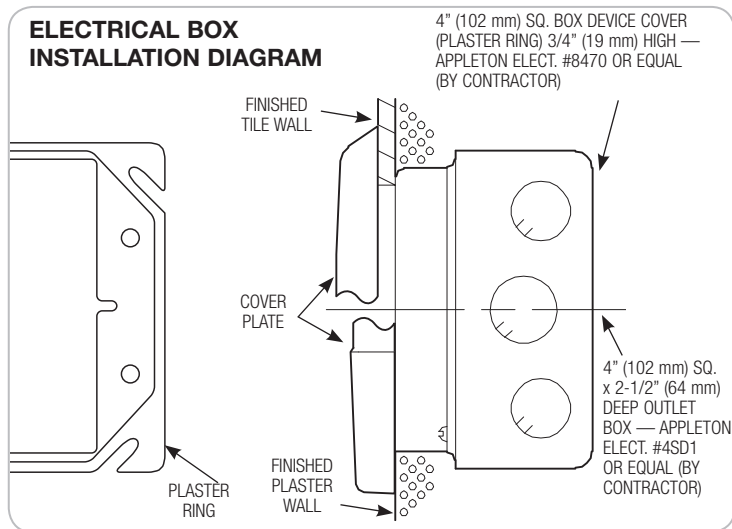

Figure 1

Transformer Installation

Install transformer (EL-154) on a 2-gang electrical box, 4" x 4" x 2½" (102 mm x 102 mm x 64 mm) in a convenient location; refer to the illustration at lower left side of this page (Figure 1).

Note: One Sloan EL-154 transformer can operate up to ten Optima equipped flushometers. Run 18-gauge wire from transformer to flushometer(s). Wire supplied by others. **DO NOT** supply power to transformer until installation of flushometer is complete.

NOTE: A maximum of ten (10) flushometer units can operate from one (1) Sloan EL-154 transformer, Class 2, UL Listed, 50 VA (min.) at 24 VAC, plate mounted.

Sensor/Solenoid Operator Box Locations

Optima ES-S flushometer exposed True Mechanical Override closet model employs one (1) electrical box. Refer to rough-in illustrations for locations.

NOTE: Install plaster ring so screw holes are on left and right side of box.

NOTE: Break tiles to allow screw holes in plaster to show.

Tools Required for Installation

- Sloan A-50 Super-Wrench™
- Wire stripper/crimping tool
- Sloan A-109 Plier Wrench or smooth jawed spud wrench
- 5/64" hex wrench (supplied)
- Slotted screwdriver

!!! IMPORTANT !!!
WITH THE EXCEPTION OF CONTROL STOP INLET, DO NOT USE PIPE SEALANT OR PLUMBING GREASE ON ANY VALVE COMPONENT OR COUPLING!

!!! IMPORTANT !!!
NEVER OPEN CONTROL STOP TO WHERE THE FLOW FROM THE VALVE EXCEEDS THE FLOW CAPABILITY OF THE FIXTURE. IN THE EVENT OF A VALVE FAILURE, THE FIXTURE MUST BE ABLE TO ACCOMMODATE A CONTINUOUS FLOW FROM THE VALVE.

!!! IMPORTANT !!!
PROTECT THE FINISH OF SLOAN'S FLUSHOMETERS — DO NOT USE TOOTHED TOOLS TO INSTALL OR SERVICE THESE VALVES. USE A SLOAN A-50 Super-Wrench™, Sloan A-109 Plier Wrench OR SMOOTH JAWED SPUD WRENCH TO SECURE ALL COUPLINGS. ALSO SEE THE "CARE AND CLEANING" SECTION.

!!! IMPORTANT !!!
THIS PRODUCT CONTAINS MECHANICAL AND/OR ELECTRICAL COMPONENTS THAT ARE SUBJECT TO NORMAL WEAR. THESE COMPONENTS SHOULD BE CHECKED ON A REGULAR BASIS AND REPLACED AS NEEDED TO MAINTAIN THE VALVE'S PERFORMANCE.

1 - INSTALL OPTIONAL SWEAT SOLDER ADAPTER (ONLY IF YOUR SUPPLY PIPE DOES NOT HAVE A MALE THREAD)

- Measure from finished wall to C/L of fixture spud. Cut pipe 1¼" (32 mm) shorter than this measurement. Chamfer O.D. and I.D. of water supply pipe.
- Slide threaded adapter fully onto pipe, until it bottoms out.
- Sweat solder the adapter to pipe.

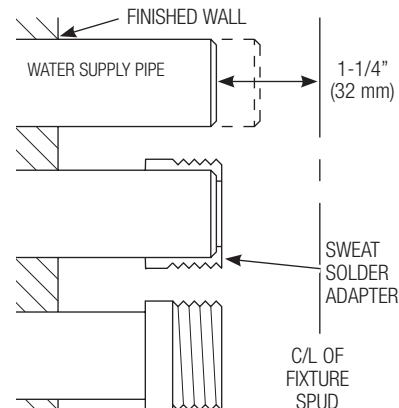

!!! IMPORTANT !!!
WITH THE EXCEPTION OF CONTROL STOP INLET, DO NOT USE PIPE SEALANT OR PLUMBING GREASE ON ANY VALVE COMPONENT OR COUPLING!

2 - INSTALL COVER TUBE, WALL FLANGE AND CONTROL STOP TO SUPPLY PIPE

- A** Measure from finished wall to first thread of adapter or threaded supply pipe (dimension "X"). Cut cover tube to this length.
- B** Slide cover tube over pipe. Slide wall flange over cover tube until against wall.
- C** Thread control stop onto water supply line. Tighten with a wrench making sure outlet is positioned as required.
- D** Tighten wall flange set screw with hex wrench. **DO NOT** install vandal resistant stop cap at this time.

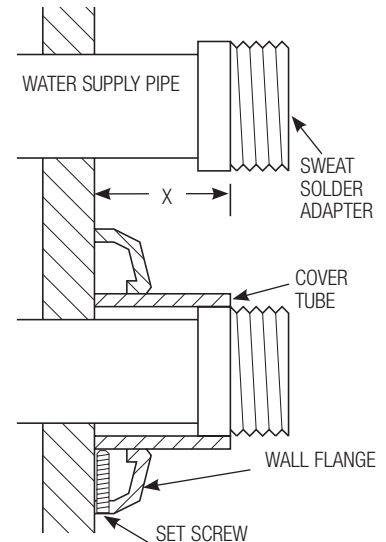
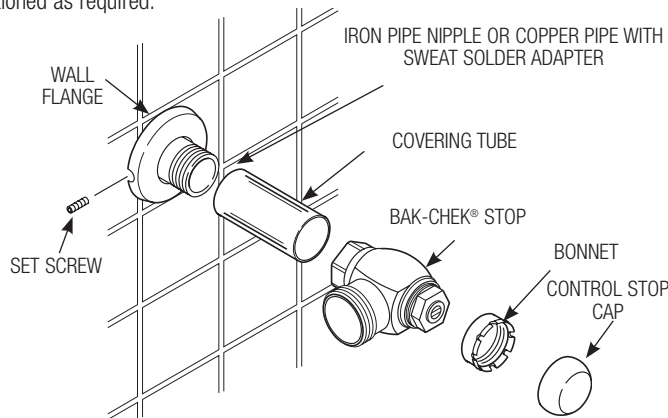

3 - INSTALL VACUUM BREAKER FLUSH CONNECTION AND BUTTON

- A** Assemble pipe, elbows, couplings, nylon slip gaskets, rubber gaskets and flanges as illustrated.
- B** Insert tube into fixture spud.
- C** Hand tighten all couplings.
- D** Install true mechanical override button into flushometer.
- E** Install valve handle cap on opening in back of valve body.

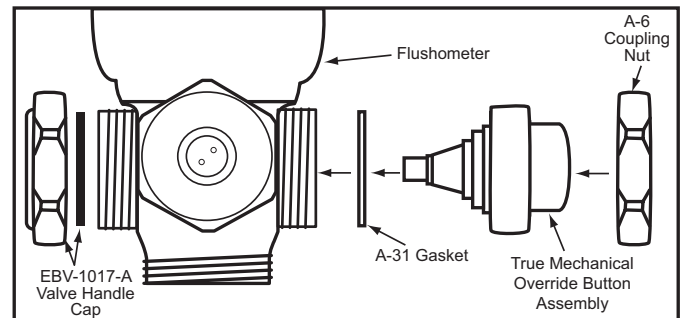
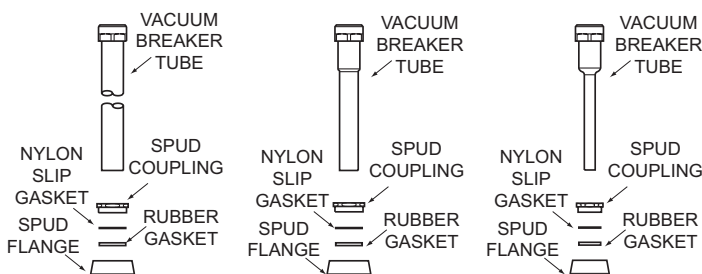

4 - INSTALL FLUSHOMETER

NOTE

For high efficiency urinal flushometers (0.5, 0.25 and 0.125 gpf), it is necessary to first insert the flow control component into the tailpiece assembly. See the H1015A flow control kit and separate instructions for details on how to install.

- A** Lubricate tailpiece o-ring with water. Insert adjustable tailpiece into control stop. Tighten tailpiece coupling by hand.
- B** Align flushometer directly above the vacuum breaker flush connection by sliding the flushometer body IN or OUT as needed. Tighten vacuum breaker coupling by hand.
- C** Align flushometer body and securely tighten first the tailpiece coupling (1), then the vacuum breaker and pipe couplings (2), and finally the spud coupling (3). Use a wrench to tighten these couplings in the order shown.

NOTE

Max. adjustment of Sloan Adjustable Tailpiece is 1/2" (13 mm) IN or OUT from the standard 4-3/4" (121 mm) (C of Valve to C of Control Stop). If roughing-in measurement exceeds 5 1/4" (133 mm), consult factory for longer tailpiece.

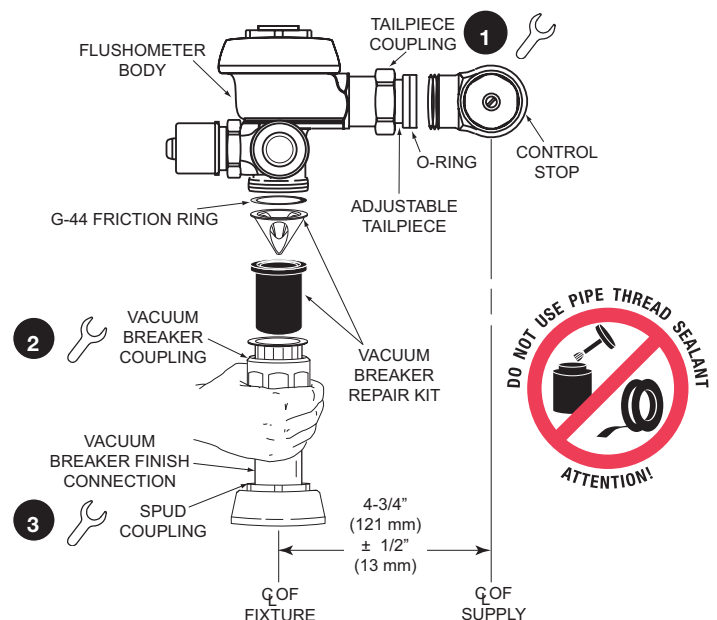

6 - INSTALL SENSOR BOX MOUNTING PLATE

- A** Install Sensor Mounting Plate using the Screws provided.

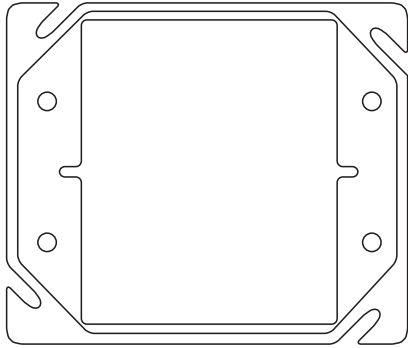

SENSOR BOX MOUNTING PLATE

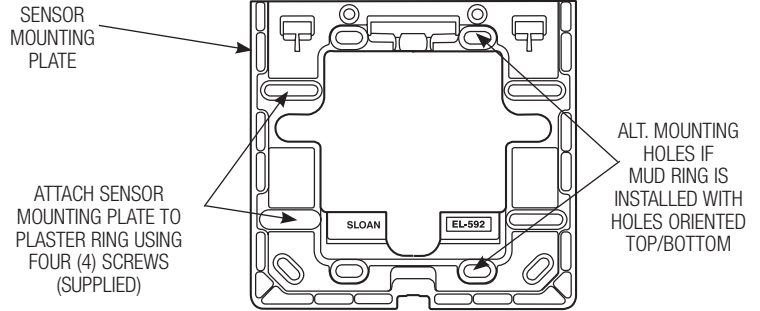

7 - ELECTRICAL HOOK-UP

- A** Be certain power is OFF to prevent damage to electrical components. Connect Sensor to Transformer and Solenoid coil EXACTLY as shown.
- B** Connect 24 volt source lead to terminal labeled "24 VAC IN" of Sensor.
- C** Connect solenoid lead to terminal labeled "TO VALVE" of Sensor.
- D** Connect remaining solenoid lead to remaining 24 volt source lead.

Wiring Diagram for One Flush Valve

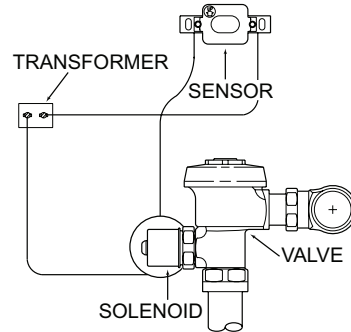

Wiring Diagram

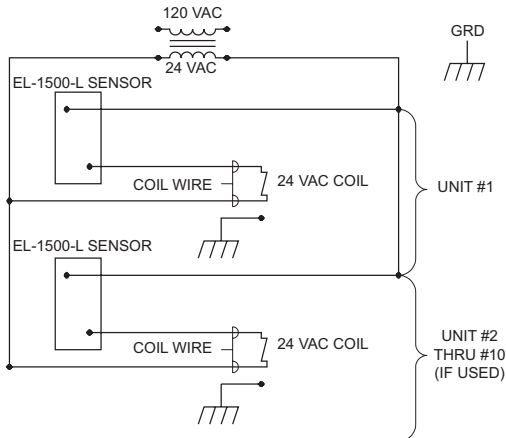

Wiring Diagram for Multiple Flush Valves

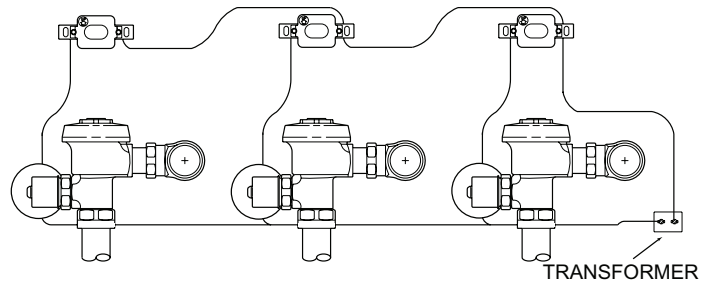

8 - INSTALL SENSOR COVER PLATE

- A** Hang Sensor Cover Plate onto Mounting Plate. Push down on Cover Plate to firmly seat.
- B** Secure Cover Plate with Screw, provided.

SENSOR BOX COVER PLATE ASSEMBLY

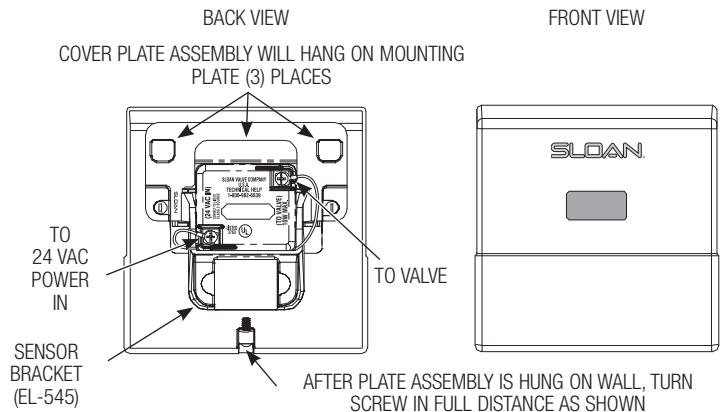

9 - INSTALL WALL FLANGE AND SECURE SOLENOID HOUSING AND COIL ASSEMBLY

- A** Locate flange on wall at dimensions shown.

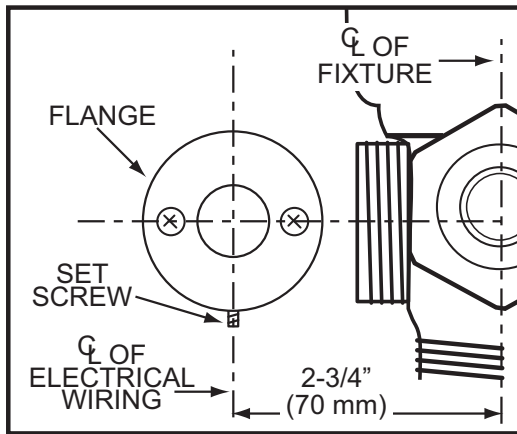

- B** Drill 1" hole to pass wires and F-15 through.
C Mount flange to wall using screws and anchors provided.
D Pull wires from transformer and sensor through flange into room.
E Cut F-15 Tail Pipe to length (long enough to pass through flange and wall).

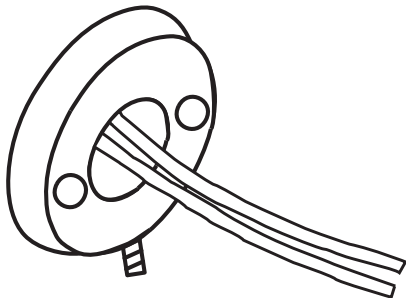

- F** Slide Solenoid wires through F-15 tail pipe and connect to transformer and sensor wires.
G Slide F-15 tail pipe into flange and hole in wall.
H While feeding wires back into the wall, carefully insert the F-15 tail into the wall flange and install solenoid operator assembly to Flushometer.

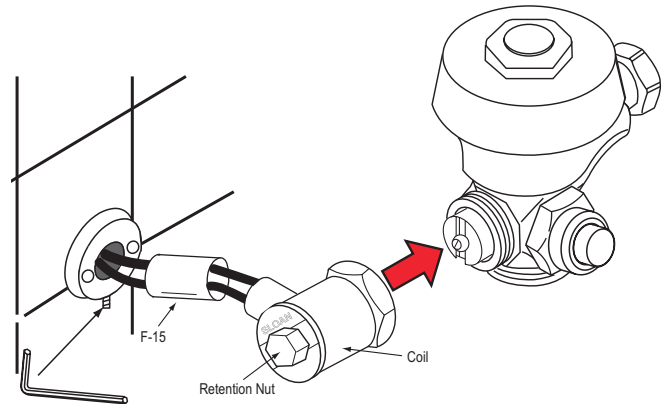

- I** Connect solenoid operator to flushometer, careful to avoid contact with white actuator cartridge. Contact may result in damage to actuator and possible leak.
J Secure solenoid operator to flushometer by tightening the solenoid coupling.

Important: Do not remove coil from solenoid plunger guide unless power has been disconnected. Failure to do so may damage sensor, coil and transformer.

- K** Screw F15 into solenoid housing and tighten by hand, then tighten set screw on wall flange.

10 - FLUSH OUT SUPPLY LINE

- A** Make sure control stop is CLOSED.
B Remove flushometer outer cover, inside cover and lift out relief valve assembly. Install flushometer inner cover and outer cover, and wrench tight.
C Open control stop. Turn on water supply to flush line of any debris or sediment.
D Shut off control stop, remove covers, remove diaphragm kit and flush under clean water.
E Reinstall diaphragm kit and relief valve assembly. Reinstall inside cover. Thread on outer cover and wrench tight. DO NOT open control stop until Step 13.

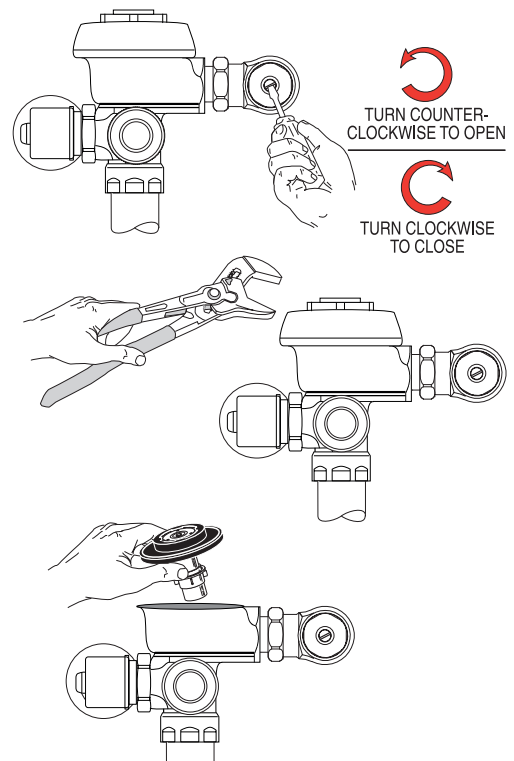

11 - POWER AND START-UP MODE

Note: It is recommended that all electronic connections be tested with the water supply OFF.

- A** Turn Power ON. The self-adaptive sensor automatically adapts to the surrounding environment when 24 volt supply is activated. No manual adjustments are required.
- B** Start-up mode will take approximately one (1) minute to complete its cycle and is important that no non-permanent target is present at this time. A continuous red light visible in sensor window indicates sensor is in the start-up mode. If the red light is flashing, this indicates that the sensor is picking up a target. Unless this target is a permanent fixture in the sensor's environment (i.e., a wall or stall door), it must be removed from the view of the sensor. In this case, disconnect the 24 volt power supply for twenty (20) seconds or more. Reconnect the 24 volt power supply at the transformer or fuse box. When start-up cycle is complete, there will be no light visible in the sensor window.

Note: If 24 volt power supply is interrupted at any time for more than fifteen (15) seconds, the start-up mode automatically repeats itself when power is restored.
- C** Incorrect wiring or a short in the 24 volt supply is indicated by a continuous warning signal seen in the sensor window. The visible red light flashes three (3) slow, three (3) times fast, three (3) slow flashes. The EL-1500 Series Sensors self-adaptive sensor is equipped with the sentinel flush feature (automatically flushes Flushometer every twenty-four (24) hours after last use).

12 - DETECTION / ACTIVATION

- A** When an object is detected, a slowly flashing red light will appear in the sensor window. After approximately eight (8) to sixteen (16) seconds/eight (8) seconds (urinal), the light will flash rapidly indicating sensor is armed and ready to activate solenoid when the object leaves the detection area. The solenoid will be activated within two (2) to four (4) seconds after non-detection.

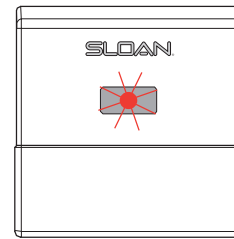

13 - TURN WATER ON AND ADJUST CONTROL STOP

- A** Adjust control stop to meet the flow rate required for proper cleansing of the fixture. Open control stop COUNTERCLOCKWISE one (1) FULL turn from the closed position.

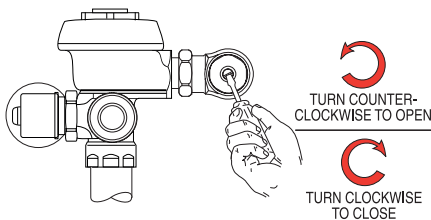

- B** Activate flushometer by placing hand in front of Optima sensor lens for ten (10) seconds and then moving it away.

- C** Adjust control stop after each flush until the rate of flow delivered properly cleanses the fixture.

!!! IMPORTANT !!!

All Sloan Flushometers are engineered for quiet operation. Excessive water flow creates noise, while too little water flow may not satisfy the needs of the fixture. Proper adjustment is made when plumbing fixture is cleansed after each flush without splashing water out from the lip AND a quiet flushing cycle is achieved.

Never open Control Stop to where the flow from the valve exceeds the flow capability of the fixture. In the event of a valve failure, the fixture must be able to accommodate a continuous flow from the valve.

14 - VANDAL RESISTANT CONTROL STOP CAP INSTALLATION AND REMOVAL

- A** Thread the plastic sleeve onto the stop bonnet until it is snug (hand tight only; do not use pliers or a wrench).

- B** Place the metal control stop cap over the plastic sleeve and using the palm of the hand, push or "pop" the cap over the fingers of the sleeve. The cap should spin freely on the insert.

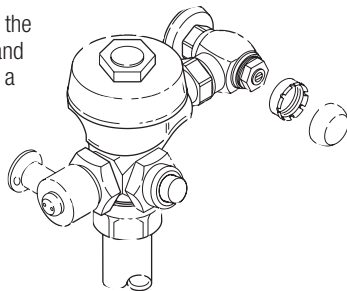

- C** **To remove Vandal Resistant Stop cap** — Using a large flat screwdriver, gently lift the cap from the control stop as follows. Insert the screwdriver blade between the bottom edge of the cap and the flat surface of the control stop body. Using the screwdriver as a lever, push the screwdriver handle straight back toward the wall. Gently lift the cap from the sleeve. It may be necessary to work the screwdriver around the diameter of the cap to further lift the cap from the sleeve.

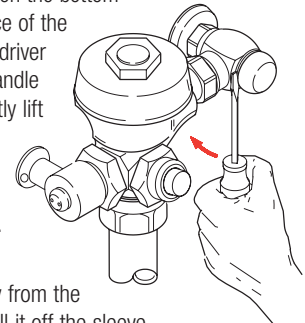

- D** Once the cap has been lifted away from the control stop, grasp the cap and pull it off the sleeve.

!!! IMPORTANT !!!

DO NOT INSTALL THE CAP ONTO THE SLEEVE UNLESS SLEEVE HAS BEEN THREADED ONTO THE CONTROL STOP BONNET. IF ASSEMBLED WHEN OFF OF THE CONTROL STOP, THE SLEEVE WILL NOT COME APART FROM THE CAP!

OPERATION

1. A continuous, invisible light beam is emitted from the Optima sensor.

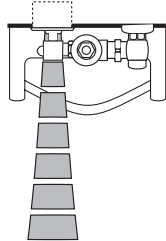

2. When a user enters the beam's effective range, for water closets 22" - 42" (559 mm - 1067 mm) and for urinals 15" - 30" (381 mm - 762 mm), the beam is reflected into the Optima scanning window and transformed into a low voltage electrical signal that activates a sixteen (16) second/eight (8) second (urinal) time delay circuit. The time delay circuit eliminates false operation from passers-by in the rest room. Once the time delay is completed, the output circuit is alerted and continues in a "hold" mode for as long as the user remains within the effective range of the sensor.

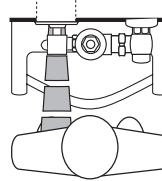
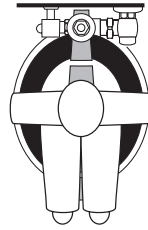

3. When the user steps away from the Optima sensor, the loss of reflected light initiates an electrical "one-time" signal that energizes the solenoid operator, and activates the flushometer to flush the fixture. This occurs on the water closet approximately three (3) seconds after indication. This delay is built into the sensor to help prevent false flushing due to movement by the user. The circuit for both water closets and urinals then automatically resets and is ready for the next user.

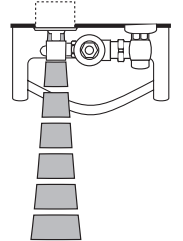
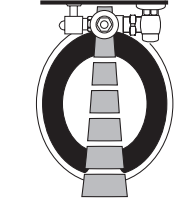

TROUBLESHOOTING GUIDE

NOTE: URINALS – When the sensor detects a user, a slow flashing red light appears in the sensor window. After eight (8) to ten (10) seconds, the light flashes rapidly to indicate that the sensor is armed. When the sensor no longer detects a user, the sensor immediately activates the solenoid valve after a 0.5 second delay.

WATER CLOSETS – Detection and activation are the same as the urinal except when the sensor no longer detects an user, the sensor activates the solenoid valve after a three (3) second delay.

- 1. PROBLEM: Valve DOES NOT function (red light does not flash when user steps in front of sensor).**

CAUSE: No power is being supplied to sensor.

SOLUTION: Ensure that the main power is turned "ON." Check transformer, leads and connections. Repair or replace as necessary.

CAUSE: EL-1500 series sensor is not operating.

SOLUTION: Replace EL-1500 series sensor.

- 2. PROBLEM: Valve DOES NOT function (red light flashes when user steps in front of sensor).**

INDICATOR: Red light stops flashing when user steps away and valve makes a "clicking" sound but DOES NOT flush.

CAUSE: No water is being supplied to the valve.

SOLUTION: Make certain that water supply is turned "ON" and the control stop is open.

CAUSE: EL-128-A cartridge is fouled or jammed.

SOLUTION: Turn electronic power to valve "OFF" (failure to do so could result in damage to the solenoid coil). Remove the solenoid operator from the valve and remove the EL-128-A cartridge. Clean and/or repair as necessary.

INDICATOR: The red light stops flashing when user steps away but the valve DOES NOT make a "clicking" sound and DOES NOT flush.

CAUSE: EL-163-A solenoid shaft assembly is fouled or jammed.

SOLUTION: Turn electronic power to valve "OFF" (failure to do so could result in damage to the solenoid coil). Remove EL-101 or EL-166 nut from the solenoid operator. Remove the coil from the solenoid operator. Use a spanner wrench or pliers to remove the EL-163-A solenoid shaft assembly from valve. Clean and/or replace as necessary. Be sure to replace plunger spring when reassembling solenoid shaft assembly.

INDICATOR: The red light flashes three (3) short flashes, three (3) long flashes then three (3) short flashes ("S-O-S") and continues to repeat this cycle even when user steps out of the sensor's detection range.

CAUSE: EL-1500 Series sensor wiring connections are incorrect.

SOLUTION: Rewire sensor to valve. One solenoid lead connects to the "TO VALVE" connection on sensor. One transformer lead connects to the "24 VAC IN" connection on sensor. Second solenoid lead and second transformer lead connect together.

CAUSE: Wiring to sensor is ground shorted.

SOLUTION: Find short in wiring circuit and correct.

CAUSE: EL-165-2 solenoid coil is burnt out or coil is not connected to solenoid plunger shaft.

SOLUTION: Reinstall or replace coil as necessary.

- 3. PROBLEM: Volume of water is insufficient to adequately siphon fixture.**

CAUSE: Control stop is not open wide enough.

SOLUTION: Adjust control stop for desired water delivery.

CAUSE: Low consumption unit is installed on water saver or conventional fixture.

SOLUTION: Replace diaphragm component parts of valve with kit that corresponds to appropriate flush volume of fixture.

CAUSE: Inadequate water volume or pressure available from supply.

SOLUTION: Increase pressure or supply (flow rate) to the valve. Consult factory for assistance.

- 4. PROBLEM: Length of flush is too long (long flushing) or valve fails to shut off.**

CAUSE: Water saver valve is installed on low consumption fixture.

SOLUTION: Replace Diaphragm component parts of valve with kit that corresponds to appropriate flush volume of fixture.

CAUSE: Relief valve in diaphragm is not seated properly or bypass hole in diaphragm is clogged.

SOLUTION: Disassemble inside Diaphragm component parts and wash parts thoroughly. Replace worn parts if necessary.

- 5. PROBLEM: Water splashes from fixture.**

CAUSE: Supply flow rate is more than necessary.

SOLUTION: Adjust control stop to meet flow rate required for proper cleansing of the fixture.

When further assistance is required, please contact Sloan Technical Support at:

1-888-SLOAN-14 (1-888-756-2614)

or visit us online at:
www.sloan.com

!!! IMPORTANT !!!
LAWS AND REGULATIONS PROHIBIT THE USE OF HIGHER FLUSHING VOLUMES THAN LISTED ON FIXTURE OR FLUSHOMETER.



CARE AND CLEANING

DO NOT USE abrasive or chemical cleaners to clean flushometers or sensor window that may dull the luster and attack the chrome or special decorative finishes of flushometer components. Use **ONLY** soap and water, then wipe dry with clean cloth or towel.

While cleaning the fixture, protect the exposed flushometer from any splattering of cleaner. Acids and cleaning fluids can discolor or remove chrome plating.

PARTS LIST

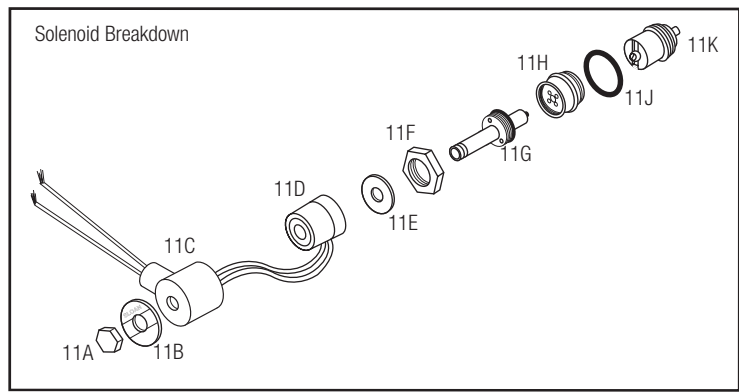
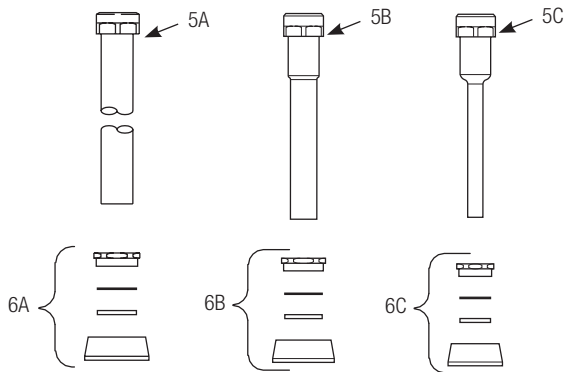
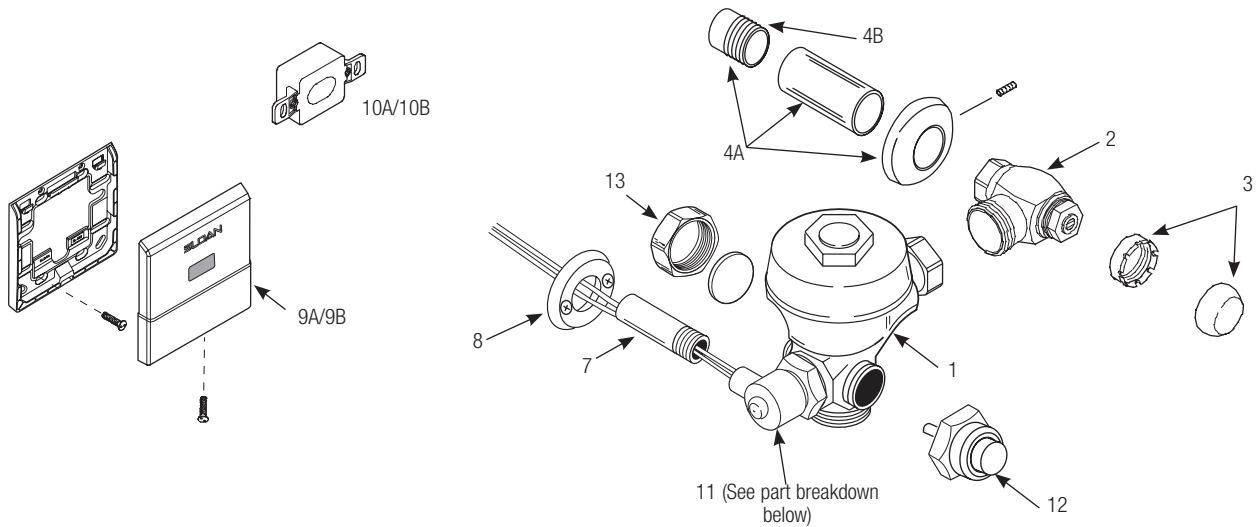

Item No.	Part No.	Description
1	‡	Solenoid Operated Valve Assembly
2	H-700-A ‡	Bak-Chek® Control Stop
3	H-1010-A	Vandal Resistant Stop Cap
4A	H-633-AA	1" (25 mm) Sweat Solder Kit
4B	H-532	Adapter, 1" NPT to 1" Tube (Concealed)
	H-535	Adapter, ¾" NPT to ¾" Tube (Concealed)
5A	V-600-AA	1½" (38 mm) CP Vacuum Breaker Assembly† (Models 110/111, 113, 115, and 116)
5B	V-600-AA	1¼" (32 mm) x 9" (229 mm) CP Vacuum Breaker Assembly (Model 180 ES-S)
5C	V-600-AA	¾" (19 mm) x 9" (229 mm) CP Vacuum Breaker Assembly (Model 186 ES-S)
6A	F-5-AT	1½" (38 mm) Spud Coupling Assembly CP (Models 110/111, 113, 115, and 116)
6B	F-5-AU	1¼" (32 mm) Spud Coupling Assembly CP (Model 180)
6C	F-5-AW	¾" (19 mm) Spud Coupling Assembly CP (Model 186)
7	F-15	Tail Assembly
8	B-110-A	Flange Assembly
9A	EL-635-A	CP Cover Plate with Sensor (Mounting Plate and Screws included) (Models 110/111, 113, 115, and 116)
9B	EL-645-A	CP Cover Plate with Sensor (Mounting Plate and Screws included) (Models 180 and 186)
10A	EL-1500-L	Sensor (Models 110/111, 113, 115, and 116)
10B	EL-1500	Sensor (Models 180 and 186)

Item No.	Part No.	Description
11	EL-124-2	CP 24V Solenoid Assembly
11A	EL-101	CP Nut for Solenoid
11B	EL-102-2	Face Plate for 24V Solenoid
11C	EL-162-2	CP 24V Solenoid Housing
11D	EL-165-2	24V Coil
11E	EL-164	Solenoid Flux Plate
11F	A-6	CP Handle Coupling
11G	EL-163-A	Solenoid Shaft Assembly Includes Gasket, Plunger, Plunger Spring, and Solenoid Shaft
11H	EL-104	Adapter for Solenoid
11J	D0-22	O-Ring
11K	EL-128-A	Actuator Cartridge Assembly Repair Kit Includes Spring, Plunger Guide, Solenoid Valve Seat, Valve Piston Assembly, and O-Ring
12	C-2-A	True Mechanical Override Button
13	EBV-1017-A	CP Valve Handle Cap Assembly

‡ Part number varies with valve model variation; consult factory.
 † Height varies with valve model variation; consult factory.

The information contained in this document is subject to change without notice.

SLOAN • 10500 SEYMOUR AVENUE • FRANKLIN PARK, IL 60131
 Phone: 1-800-982-5839 or 1-847-671-4300 • Fax: 1-800-447-8329 or 1-847-671-4380 • www.sloan.com