





ASSEMBLY INSTRUCTION FOR 24520 RECTANGLE DINING TABLE

HARDWARE LIST			
NO.	ITEM	DESCRIPTIN	QTY.
1		JCB Bolt M6X13 MM	4
2		Allen key	1
3		HEX Bolt M8X25 MM	22
4		Flat washer M8X25 MM	22
5		Wrench	1

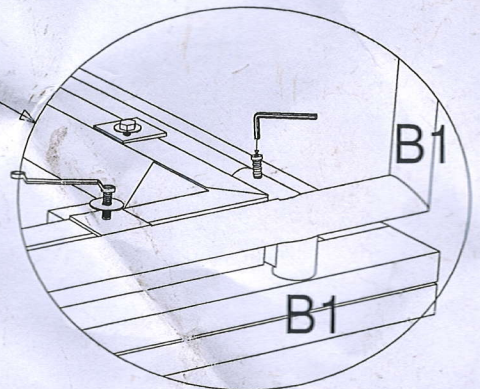
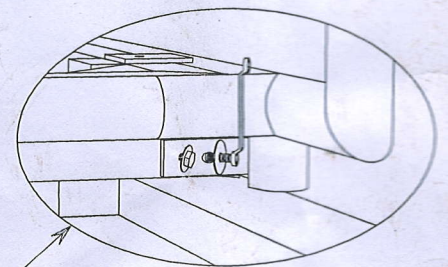
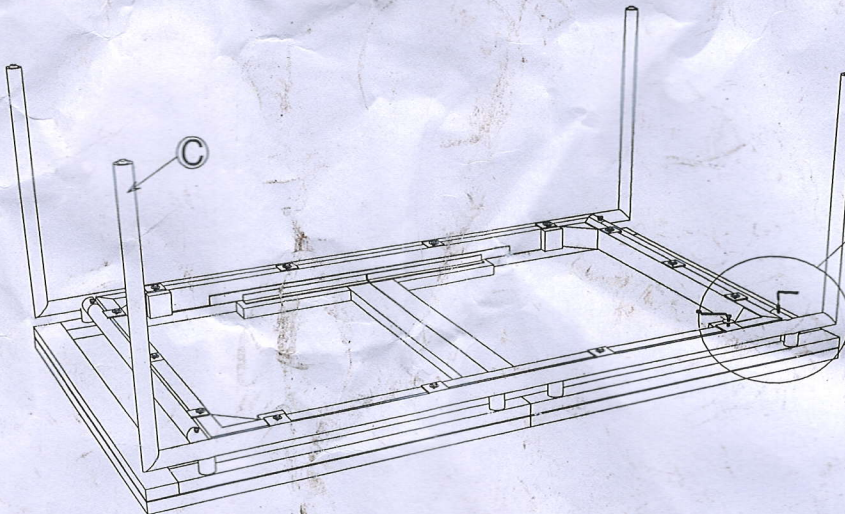
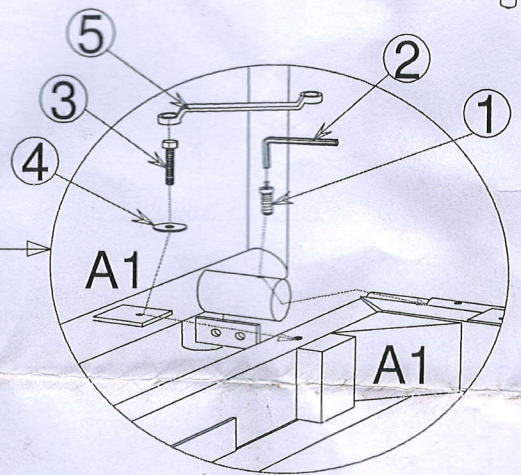
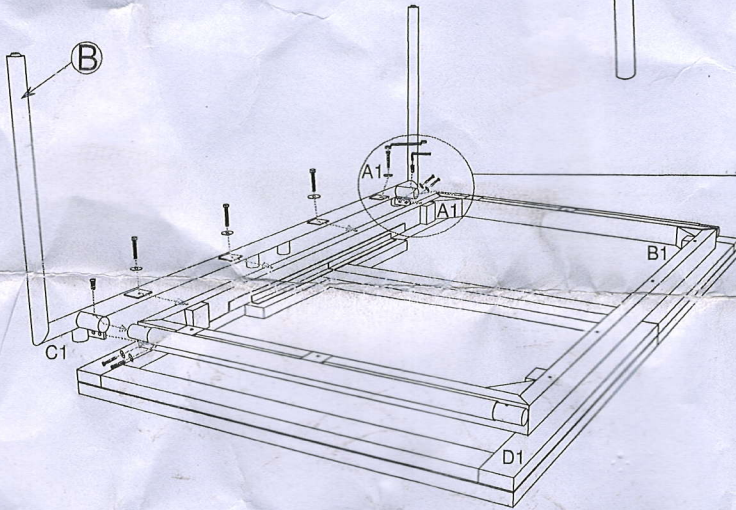
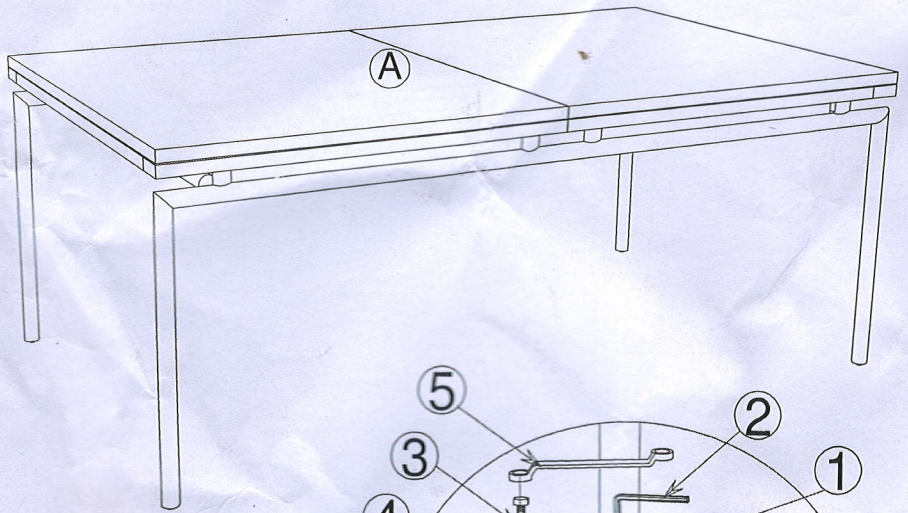

TO ASSEMBLY :

STEP 1 : Unpack Dining table Part "A" and rest on floor with top upside down.

STEP 2 : Assemble iron leg assembly B & C with bottom iron pipes on Part 'A'.

STEP 3 : Fix the pipes with JCB bolt (1) , HEX bolt (3) & washer (4) Using Allen key (2) & wrench (5) matching the numbers A1-A1, B1-B1, C1-C1 & D1-D1.

STEP 4 : Tighten bolts in step 3 fully with Allen key (2) & wrench (5) then carefully turn the Dining table upright.