

TOP VIEW

MINIMUM SERVICE CLEARANCE PER NATIONAL, STATE & LOCAL CODE. SEE NOTES 1&2.

SEE RECEIVER DRAWING ACAC75009 FOR FURTHER INFO

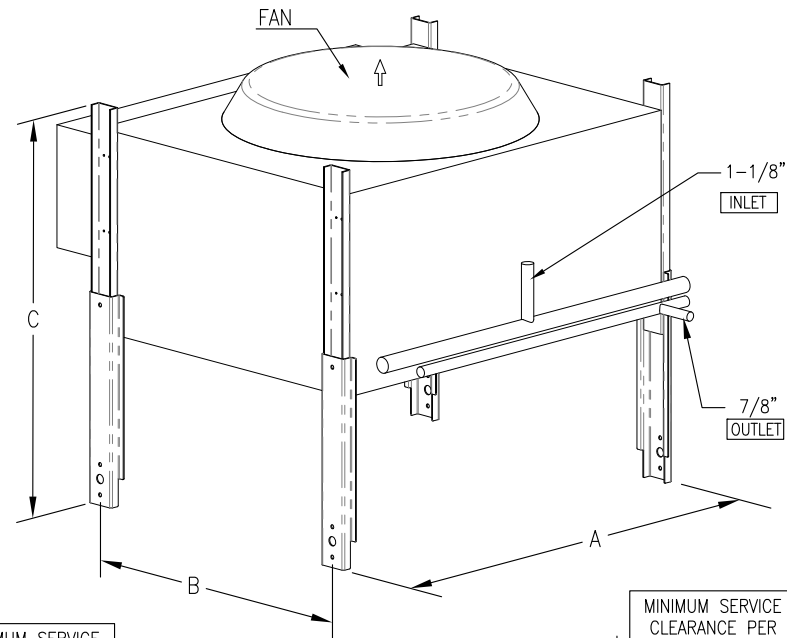

DIMETRIC VIEW
RECEIVER REMOVED

MINIMUM SERVICE CLEARANCE PER NATIONAL, STATE & LOCAL CODE. SEE NOTES 1&2.

MINIMUM SERVICE CLEARANCE PER NATIONAL, STATE & LOCAL CODE. SEE NOTES 1&2.

DIMENSIONS			
SKU	A	B	C
ACCD75214	42.72 [1085]	30.00 [762]	37.71 [958]
ACCD75215	42.72 [1085]	40.00 [1016]	37.71 [958]

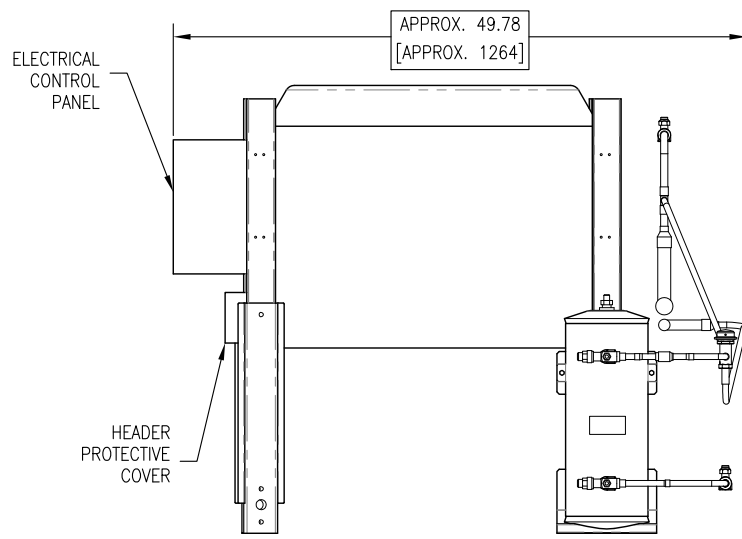

FRONT VIEW

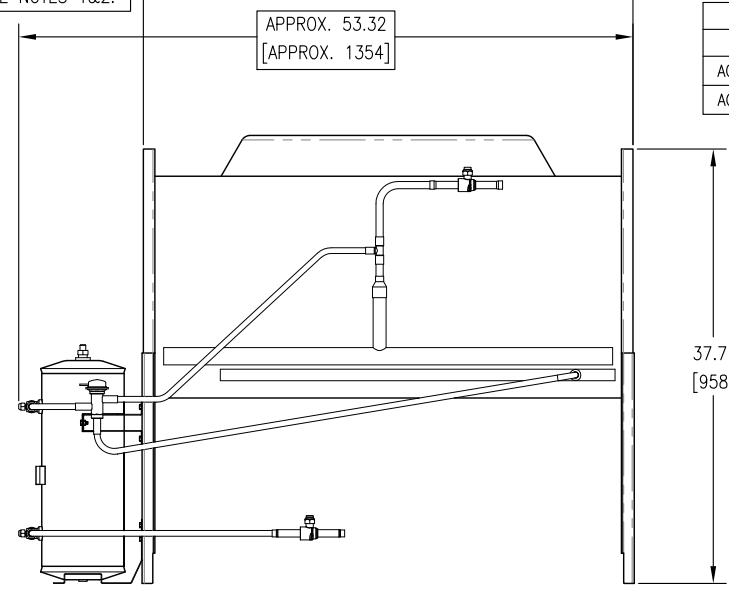

SIDE VIEW

- NOTES:
1. INSTALLATION SHALL COMPLY WITH ALL APPLICABLE NATIONAL, STATE AND LOCAL CODES.
 2. SEE PRODUCT DOCUMENTATION FOR FURTHER INFORMATION.
 3. UNLESS OTHERWISE SPECIFIED, ALL DIMENSIONS ARE IN INCHES [MILLIMETERS].

THIS DRAWING AND SPECIFICATIONS HEREIN ARE THE PROPERTY OF SCHNEIDER ELECTRIC AND SHALL NOT BE COPIED, REPRODUCED OR USED IN WHOLE OR IN PART, AS THE BASIS FOR THE MANUFACTURE OR SALE OF ITEMS WITHOUT WRITTEN PERMISSION FROM SCHNEIDER ELECTRIC. THIS DRAWING IS BASED UPON LATEST AVAILABLE INFORMATION AND IS SUBJECT TO CHANGE WITHOUT NOTICE.



TITLE: InfraStruXure
AIR COOLED CONDENSERS
CONDENSER 1-FAN, SINGLE CIRCUIT
230V/1 ϕ /60Hz
GENERAL MECHANICAL LAYOUT

DWG NO: ACCD75214-75215-MM1 REV 03

DRAWN:	M CRAVEN	04-MAY-11	THIRD
ENGINEER:	D MOODY	04-MAY-11	ANGLE
PROJECT:	SUBMITTAL DRAWINGS SHEET 1 OF 4	APPROVED:	C COSTEA 04-MAY-11 PROJ

ACCD75214

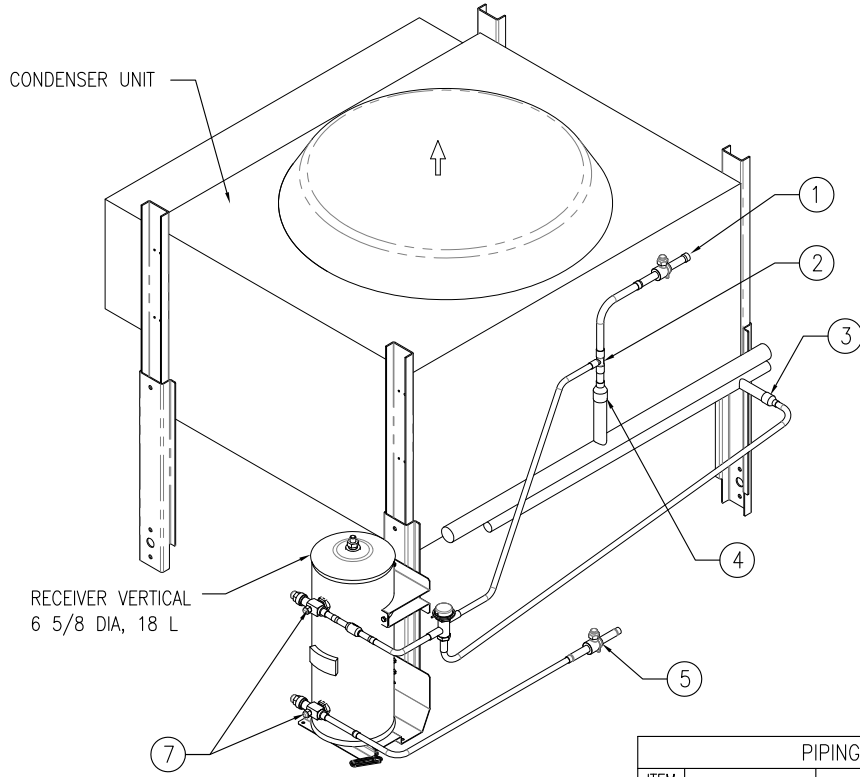

ISOMETRIC VIEW

ACCD75215

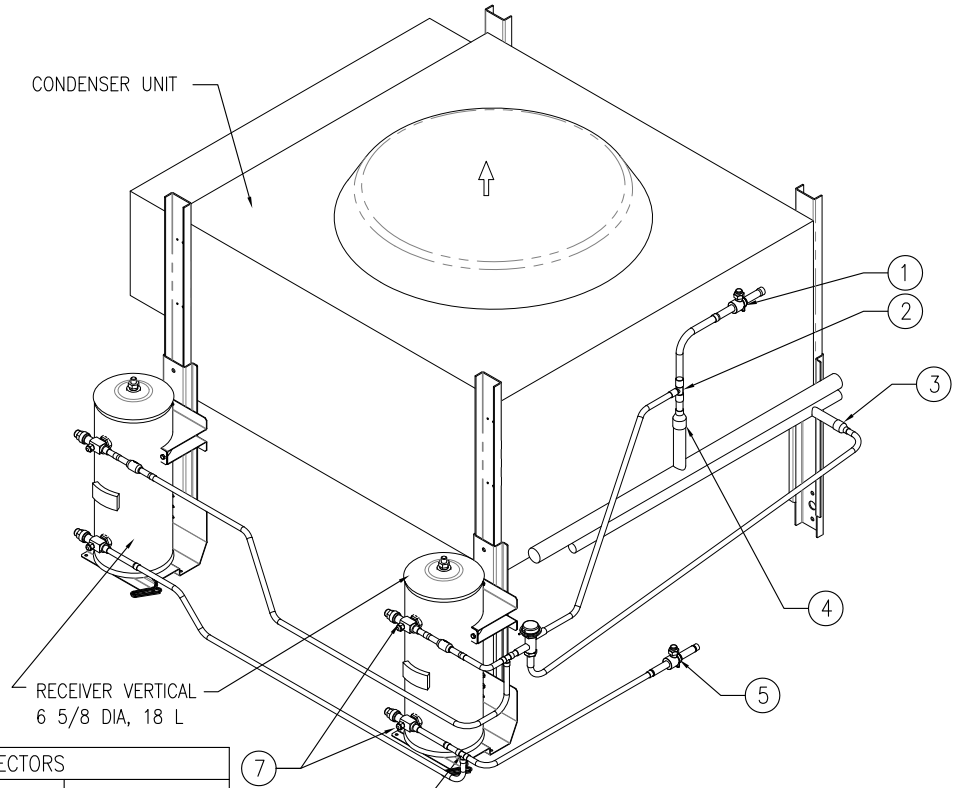

ISOMETRIC VIEW

PIPING CONNECTORS			
ITEM NO.	TYPE	SIZE	PROVIDED BY
①	ODF BALL VALVE	5/8"	CONTRACTOR
②	TEE	5/8"x5/8"x1/2"	CONTRACTOR
③	COUPLING	7/8"x1/2"	CONTRACTOR
④	COUPLING	1-1/8"x5/8"	CONTRACTOR
⑤	ODF BALL VALVE	1/2"	CONTRACTOR
⑥	TEE	1/2"	CONTRACTOR
⑦	VALVE, ROTO	1.00"-14 NS 1/2"	SCHNEIDER ELECTRIC

SPECIFICATION													
SKU	DESCRIPTION	AMBIENT TEMP 'F[°C]	AIR QUANTITY CFM [l/s]	FAN		MAX. CIRC. AVAIL.	MOTOR DATA				CONNECTIONS ODS		APPROX NET WGHT LBS[KG]
				No	Dia In [mm]		VOLTAGE	FLA	MCA	MOP	HOT GAS	LIQUID	
ACCD75214	FCB-5 FSC, SINGLE CIRCUIT 2.4MBH/1F TD, 230V/1φ/60Hz	95 [35] & 104 [40]	5050 [2380]	1	24 [610]	8	208-240V, 1φ, 60Hz	4.8	15	15	1 1/8 IN	7/8 IN	180 [82]
ACCD75215	FCB-8 FSC, SINGLE CIRCUIT 4.0MBH/1F TD, 230V/1φ/60Hz	115 [46]	6450 [3040]	1	26 [660]	16	208-240V, 1φ, 60Hz	4.8	15	15	1 1/8 IN	7/8 IN	260 [118]

NOTES:

1. INSTALLATION SHALL COMPLY WITH ALL APPLICABLE NATIONAL, STATE AND LOCAL CODES.
2. SEE PRODUCT DOCUMENTATION FOR FURTHER INFORMATION.
3. FLOODED RECEIVER SHALL BE FIELD WIRED.

FLA = Full Load Amps
MCA = Minimum circuit amperes
MOP = Maximum overcurrent protection

THIS DRAWING AND SPECIFICATIONS HEREIN ARE THE PROPERTY OF SCHNEIDER ELECTRIC AND SHALL NOT BE COPIED, REPRODUCED OR USED IN WHOLE OR IN PART, AS THE BASIS FOR THE MANUFACTURE OR SALE OF ITEMS WITHOUT WRITTEN PERMISSION FROM SCHNEIDER ELECTRIC. THIS DRAWING IS BASED UPON LATEST AVAILABLE INFORMATION AND IS SUBJECT TO CHANGE WITHOUT NOTICE.



TITLE: InfraStruXure
AIR COOLED CONDENSERS
CONDENSER 1-FAN, SINGLE CIRCUIT
230V/1φ/60Hz
RECEIVER AND PIPING DETAILS W/SKU SPECIFICATIONS
PROJECT: SUBMITTAL DRAWINGS SHEET 2 OF 4

DWG NO: ACCD75214-75215-MM2 REV 03
DRAWN: M CRAVEN 04-MAY-11 THIRD ANGLE
ENGINEER: D MOODY 04-MAY-11
APPROVED: C COSTEA 04-MAY-11 PROJ

BOTTOM PIPING

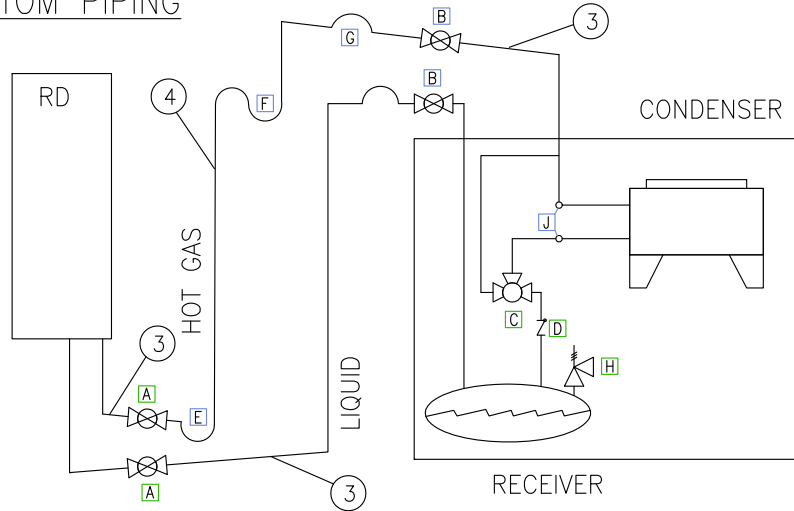

TOP PIPING

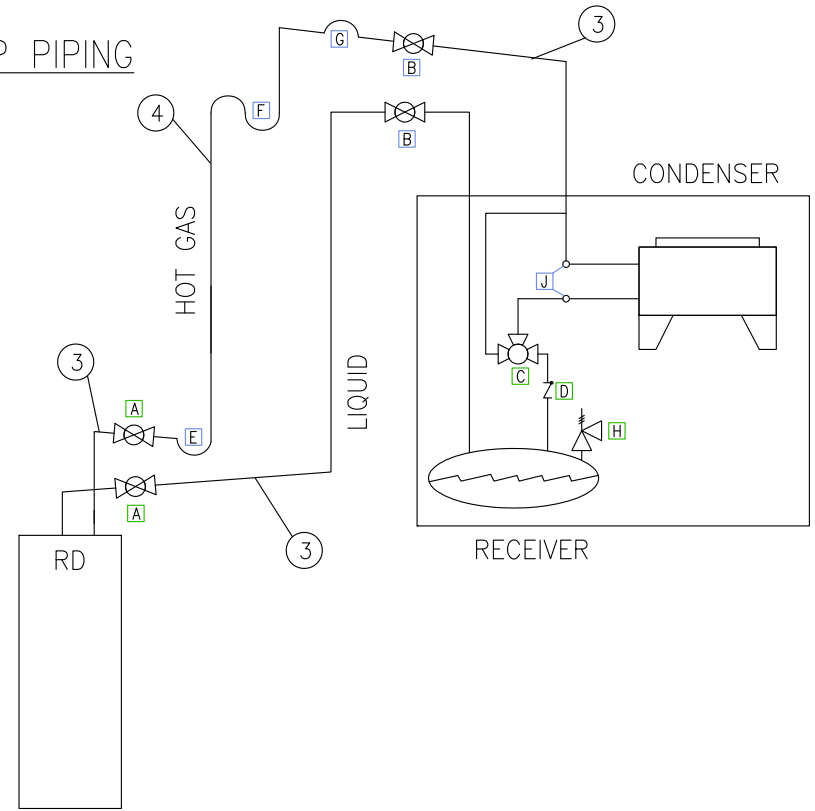

FITTINGS AND FIXTURES			
SYMB	ITEM NO	ITEM	PROVIDED BY
	[A]	SHUTOFF VALVE	SCHNEIDER ELECTRIC
	[B]	SHUTOFF VALVE	CONTRACTOR
	[C]	HEAD PRESSURE CONTROL VALVE	SCHNEIDER ELECTRIC
	[D]	CHECK VALVE	SCHNEIDER ELECTRIC
	[E]	P-TRAP	CONTRACTOR
	[F]	S-TRAP	CONTRACTOR
	[G]	INVERTED TRAP	CONTRACTOR
	[H]	PRESSURE RELIEF VALVE	SCHNEIDER ELECTRIC
	[J]	SHRADER VALVE	CONTRACTOR

NOTES:

1. INSTALLATION SHALL COMPLY WITH ALL APPLICABLE NATIONAL, STATE AND LOCAL CODES.
2. SEE PRODUCT DOCUMENTATION FOR FURTHER INFORMATION.
3. PITCH IN DIRECTION OF REFRIGERANT FLOW
1/2" PER 10'-0" (4mm PER 1m)
4. REDUCTION OF PIPING DIAMETER FOR VERTICAL RUN (IF NECESSARY)

Charging Table

Condenser SKU	Selected Ambient Temperature in °F (°C)	Condenser Summer Charge (lb)	Condenser Flooded Charge (lb) For Different Minimum Outdoor Ambient Temperatures				
			4° C (40° F)	-7° C (20° F)	-18° C (0° F)	-29° C (-20° F)	-40° C (-40° F)
ACCD75214	95 - 105 (35 - 40)	4.9	12.1	12.9	13.3	13.6	13.9
ACCD75215	115 (46)	8.5	21.1	22.4	23.1	23.6	24.1

Total Charge - RD Unit Charge + Condenser Summer Charge + Condenser Flooded Charge (for minimum possible ambient temperature) + Liquid R410A in liquid pipe

RD Unit Charge is 1.6 kg (3.5 lbs)

Density of liquid R410a at 105° F 260 psig is 61.0 lbm/ft3

Cross sectional area for 1/2 inch OD ACR pipe is 0.0010554 ft2

R410A in 1/2 OD liquid line - Area x Length in ft x density - 0.0010554 (ft2) x L (ft) x 61.0 (lbm/ft3)

Liquid line charge for 1/2 inch OD ACR copper tube is 0.095 kg/m (0.0644 lb/ft)

Cross sectional area for 5/8 inch OD ACR pipe is 0.001619 ft2

R410A in 5/8 OD liquid line - Area x Length in ft x density - 0.001619 (ft2) x L (ft) x 61.0 (lbm/ft3)

Liquid line charge for 5/8 inch OD ACR copper tube is 0.146 kg/m (0.099 lb/ft)

Example: Calculate total R410A charge for FCB5, 25 ft long 1/2 in OD liquid piping and minimum outdoor design temperature is 20° F.

Total R410A charge = 3.5 + 4.9 + 13.6 + (25 (0.0644)) = 23.6 lb.

THIS DRAWING AND SPECIFICATIONS HEREIN ARE THE PROPERTY OF SCHNEIDER ELECTRIC AND SHALL NOT BE COPIED, REPRODUCED OR USED IN WHOLE OR IN PART, AS THE BASIS FOR THE MANUFACTURE OR SALE OF ITEMS WITHOUT WRITTEN PERMISSION FROM SCHNEIDER ELECTRIC. THIS DRAWING IS BASED UPON LATEST AVAILABLE INFORMATION AND IS SUBJECT TO CHANGE WITHOUT NOTICE.

Schneider Electric

TITLE: InfraStruXure
AIR COOLED CONDENSERS
CONDENSER 1-FAN, SINGLE CIRCUIT
230V/1 ϕ /60Hz
PIPING DIAGRAM

DWG NO: ACCD75214-75215-PD REV 03

DRAWN: M CRAVEN 04-MAY-11 PROJ
ENGINEER: D MOODY 04-MAY-11 ANGLE

PROJECT: SUBMITTAL DRAWINGS SHEET 3 OF 4 APPROVED: C COSTEA 04-MAY-11 N.A.

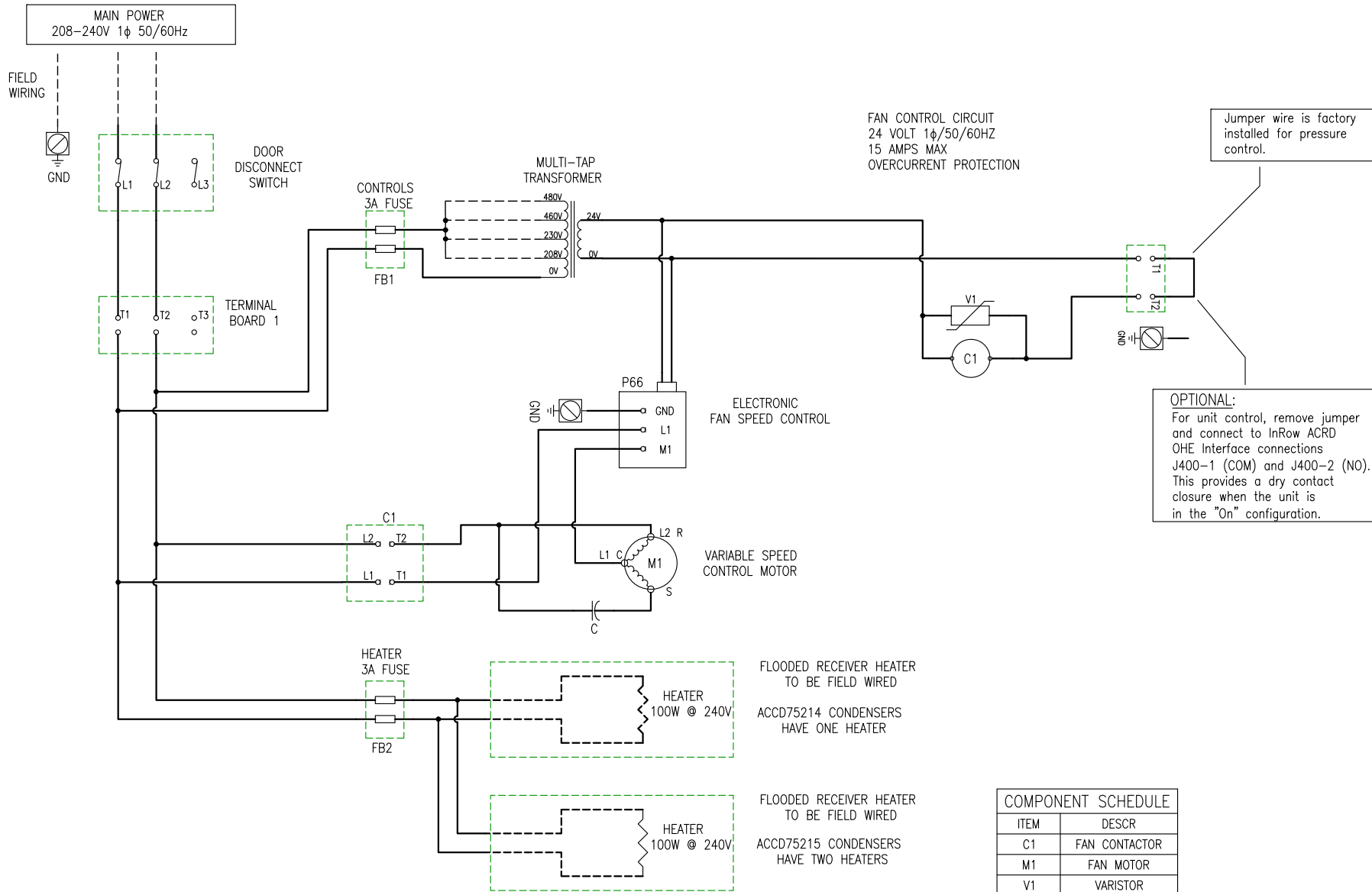

FAN CONTROL CIRCUIT
 24 VOLT 1φ/50/60HZ
 15 AMPS MAX
 OVERCURRENT PROTECTION

Jumper wire is factory installed for pressure control.

OPTIONAL:
 For unit control, remove jumper and connect to InRow ACRD OHE Interface connections J400-1 (COM) and J400-2 (NO). This provides a dry contact closure when the unit is in the "On" configuration.

FLOODED RECEIVER HEATER TO BE FIELD WIRED
 ACCD75214 CONDENSERS HAVE ONE HEATER

FLOODED RECEIVER HEATER TO BE FIELD WIRED
 ACCD75215 CONDENSERS HAVE TWO HEATERS

COMPONENT SCHEDULE	
ITEM	DESCR
C1	FAN CONTACTOR
M1	FAN MOTOR
V1	VARISTOR
C	CAPACITOR

- NOTES:**
1. INSTALLATION SHALL COMPLY WITH ALL APPLICABLE NATIONAL, STATE AND LOCAL CODES.
 2. SEE PRODUCT DOCUMENTATION FOR FURTHER INFORMATION.
 3. UNIT SHALL BE GROUNDED
 4. SHALL BE FIELD FUSED, REFER TO UNIT NAMEPLATE FOR VOLTAGE, CURRENT REQUIREMENTS.
 5. ALL MOTORS ARE INHERENTLY PROTECTED.
 6. WIRE FOR FIELD CONNECTION SHALL BE MIN. 90° C MTW.
 7. SET P66 ELECTRONIC FAN SPEED CONTROL TO START AT 360psig, 90psig THROTTLING. FACTORY TO SET RANGE USING NITROGEN OR DRY AIR.
 8. USE COPPER CONDUCTORS ONLY.
 9. ACRD UNITS PROVIDE AN OPEN/CLOSED CONTACT FOR FIELD WIRING.

- LINETYPE LEGEND:**
1. SOLID LINES INDICATE FACTORY WIRING
 2. DASHED LINES INDICATE CONTRACTOR FIELD WIRING

THIS DRAWING AND SPECIFICATIONS HEREIN ARE THE PROPERTY OF SCHNEIDER ELECTRIC AND SHALL NOT BE COPIED, REPRODUCED OR USED IN WHOLE OR IN PART, AS THE BASIS FOR THE MANUFACTURE OR SALE OF ITEMS WITHOUT WRITTEN PERMISSION FROM SCHNEIDER ELECTRIC. THIS DRAWING IS BASED UPON LATEST AVAILABLE INFORMATION AND IS SUBJECT TO CHANGE WITHOUT NOTICE.



TITLE: InfraStruXure AIR COOLED CONDENSERS 1-FAN, SINGLE CIRCUIT 230V/1φ/60Hz WIRING DIAGRAM

DWG NO: ACCD75214-75215-WD REV 03
 DRAWN: M CRAVEN 04-MAY-11 PROJ
 ENGINEER: D MOODY 04-MAY-11 ANGLE
 APPROVED: C COSTEA 04-MAY-11 N.A.

PROJECT: SUBMITTAL DRAWINGS SHEET 4 OF 4