

ASSEMBLY INSTRUCTION

BLACK FINISH 48" DINING TABLE

A TABLE TOP

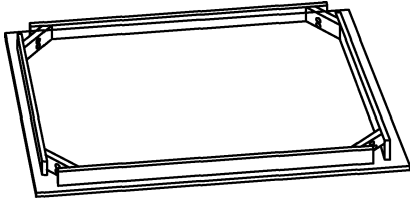

1 pc

B TABLE LEG

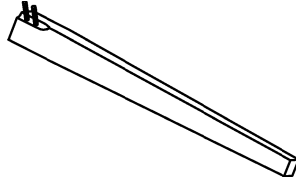

4 pcs

C HEX NUT
 $\varnothing \frac{5}{16}$ " x 12 mm

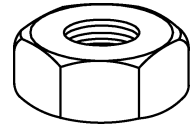

8 pcs

D FLAT WASHER
 $\varnothing \frac{5}{16}$ " x 19 mm

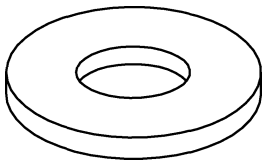

8 pcs

E LOCK WASHER
 $\varnothing \frac{5}{16}$ " x 13 mm

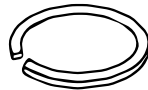

8 pcs

F WRENCH

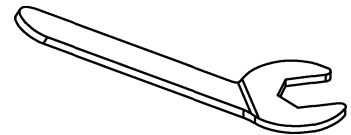

1 pc

This page lists all the contents included in the box. Please take the time to identify the hardware as well as the individual components to this product. As you unpack and prepare for assembly, place the contents on a carpeted or padded area to protect them from damage.

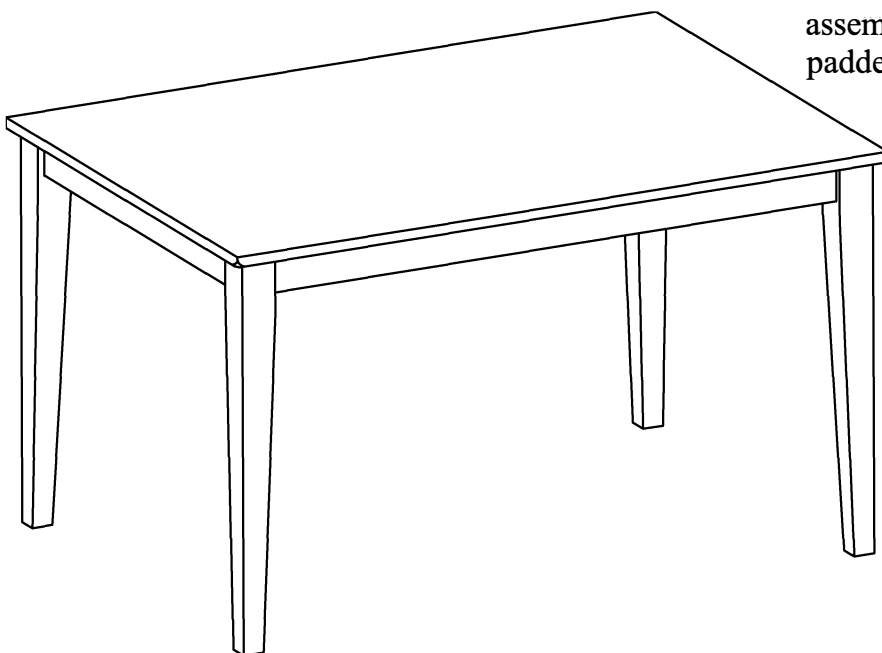

- 1** Place the Table Top (A) up side down on the floor with a piece of cloth or carpet underneath to prevent the finish from scratching. Attach the Table Leg (B) to Table Top (A) using Flat Washer (D), Lock Washer (E) and Hex Nut (C) by Wrench (F). Do not fully tighten.

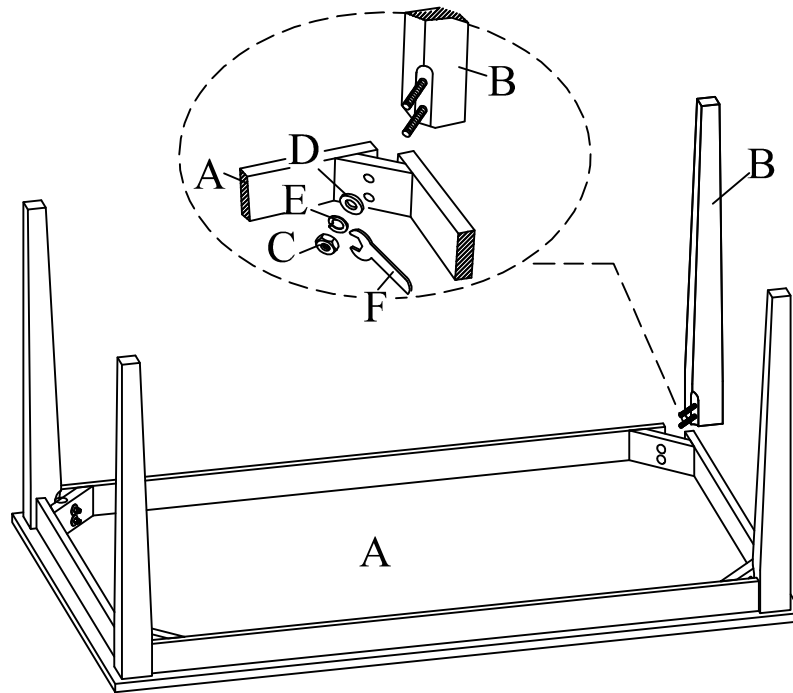

- 2** Turn the Table to upright position, place it on flat surface and adjust legs so that Table is level and does not wobble. Hand tighten only at this moment by using Wrench (F). Assembly product is now completed .

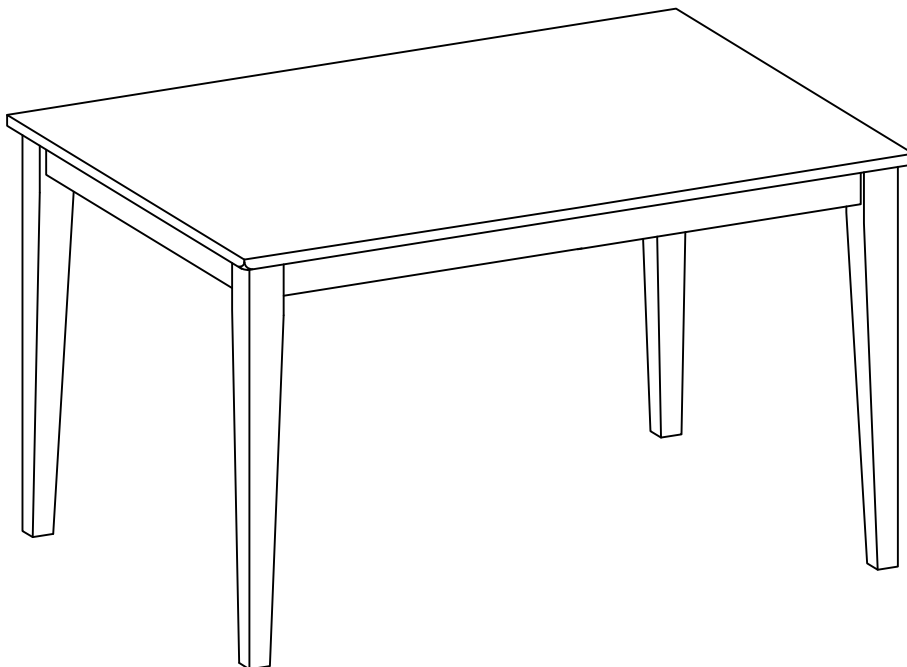









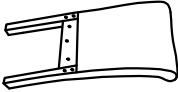

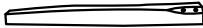
Cleaning & Care :

Treat surface with care. Surface is resistant to scratches but is not scratch resistant. Clean surface with a dry or damp soft cloth. Do not use abrasive cleaners. Hardware may loosen over time. Periodically check that all connections are tight.

ASSEMBLY INSTRUCTION

PARSON CHAIR

A Chair Back	B Seat	C Front Leg	D Lock Washer M8x13mm
			
1pc	1pc	2pcs	9pcs
E Flat Washer M8x19mm	F Bolt M8x80mm	G Bolt M8x60mm	H Bolt M8x45mm
			
9pcs	4pcs	4pcs	1pc
I Allen Key M5	J Wood Dowel Ø10x30mm		
			
1pc	2pcs		

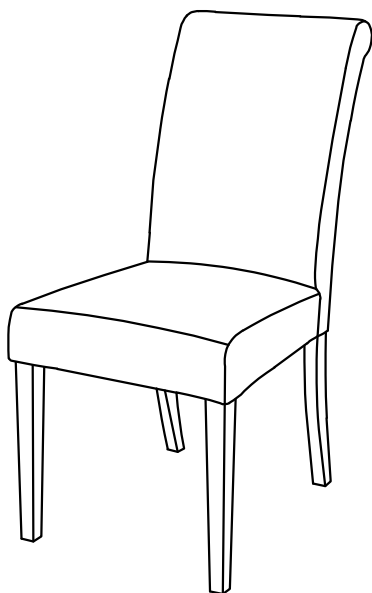

This page lists all the contents included in the box. Please take the time to identify the hardware as well as the individual components to this product. As you unpack and prepare for assembly, place the contents on a carpeted or padded area to protect them from damage.

- Put the Seat (B) on a smooth flat surface, attach Front Leg (C) to the Seat (B) using Bolt (G), Lock Washer (D) and Flat Washer (E) on both holes of Seat (B) by Allen Key (I). Turn the Allen Key (I) in Bolt (G). But not too tight. Attach Wood Dowel (J) to Seat (B) back.

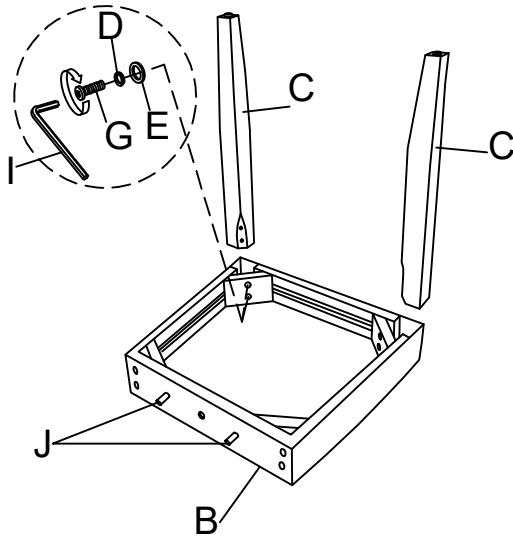

Take the Allen Key, and turn the bolts until the legs are secure. **DO NOT TIGHTEN COMPLETELY.** Stop when you feel you are adding force to tighten the bolt.

- Put Chair Back (A) on a smooth flat surface, attach the Seat (B) to the Chair Back (A) using Bolt (F) & Bolt (H), Lock Washer (D), Flat Washer (E) in both holes of Seat (B) and Chair Back (A). Turn the Allen Key (I) in Bolt (F) & Bolt (G).

Stand chair up on an even surface and check that it is balanced. If there is a slight wobble, apply downward pressure in the corner where a leg is uneven. Keeping pressure in that corner, tighten all bolts. If balanced, apply downward pressure evenly in the center and tighten all bolts. Do not over-tighten beyond hole depth.

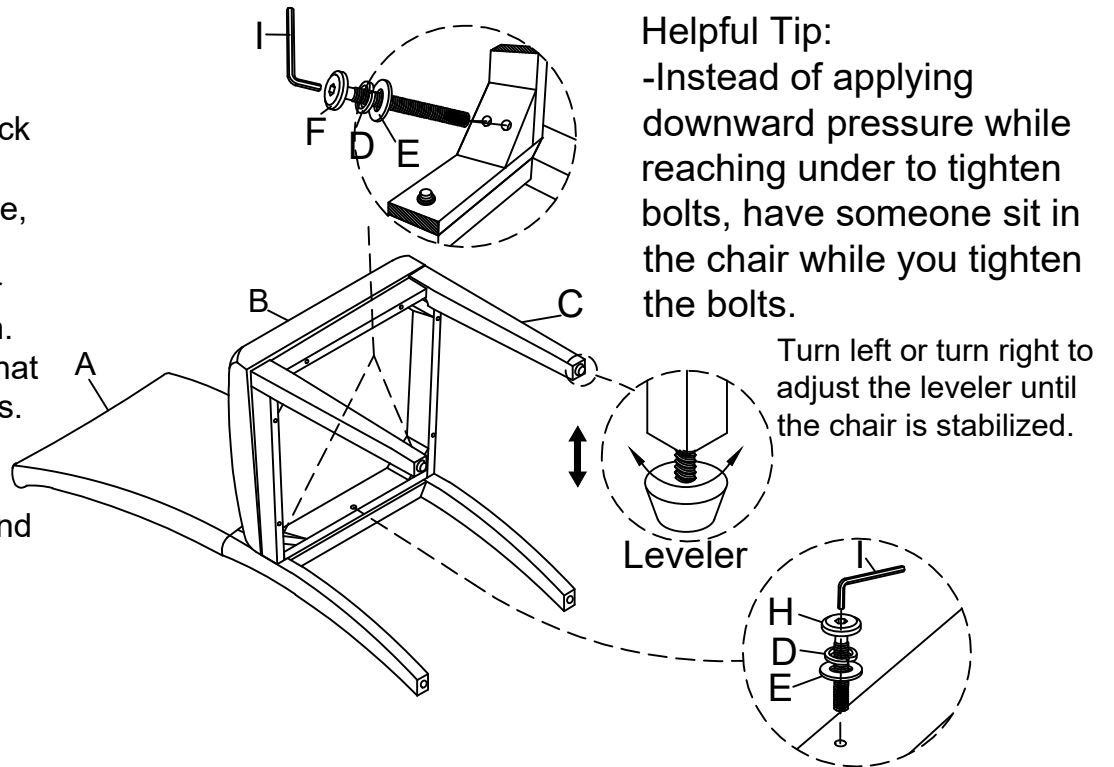

Helpful Tip:
-Instead of applying downward pressure while reaching under to tighten bolts, have someone sit in the chair while you tighten the bolts.

Turn left or turn right to adjust the leveler until the chair is stabilized.

Cleaning & Care

Treat surface with care. Surface is resistant to scratches but is not scratch resistant. Clean surfaces with a dry or damp soft cloth. Do not use abrasive cleaners. Hardware may loosen over time. Periodically check that all connections are tight.