









ASSEMBLY INSTRUCTIONS

MORELLO COLLECTION

ITEM#: U2505-13P1

DESCRIPTION : MORELLO GLIDER RECLINER W/PWR FR

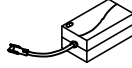
Thank you for purchasing this quality product. Be sure to check all packing materials carefully for small parts, which may have come loose during shipment. Identify and count all items and compare with the parts list shown below. It is recommended to have two people during assembling and to remove the back and base of the furniture out from the box. **Please follow the drawings below to assemble the item**

Parts List			
NO.	DESCRIPTION	SKETCH	Q'TY
A	Seat		1 PC
B	Backrest		1 PC
C	Left Side Facing (LSF) Wing		1 PC
D	Right Side Facing (RSF) Wing		1 PC
E	Transformer		1 PC
F	Plug		1 PC

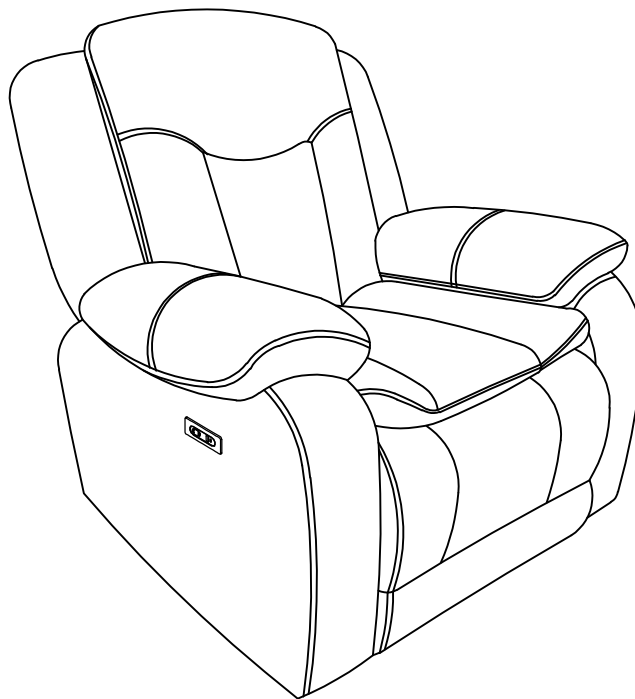

All images shown are for illustration purpose only.
Actual product may vary due to product enhancement.

ASSEMBLY INSTRUCTIONS

MORELLO COLLECTION

ITEM#: U2505-13P1

DESCRIPTION : MORELLO GLIDER RECLINER W/PWR FR

Step 1:

Attach Backrest (B) to the Seat (A).

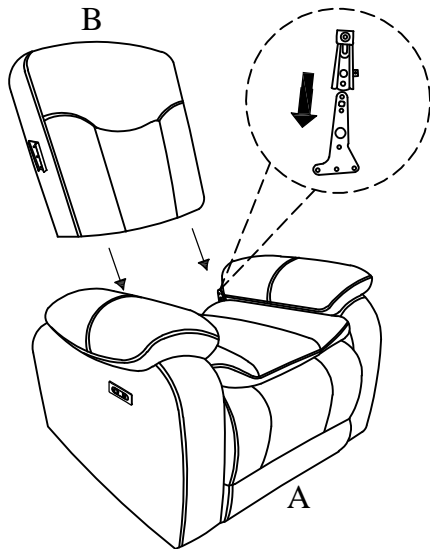

Step 2:

Attach the LSF wing (C) and RSF wing (D) to the Backrest (B).

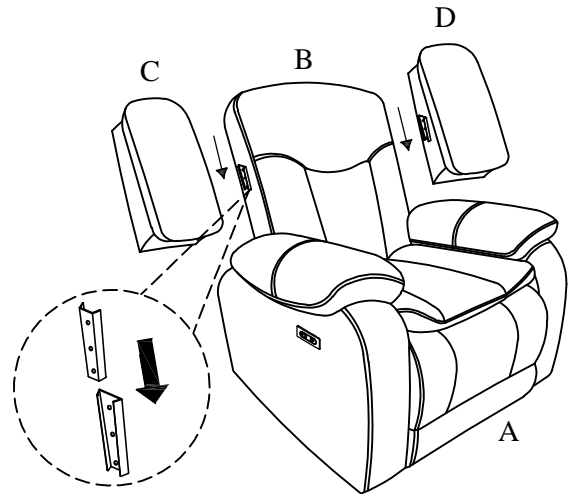

Step 3:

Conned the Transformer (E) to the power wire on the seat (A) and then connect the Plug (F) to the Transformer (E).

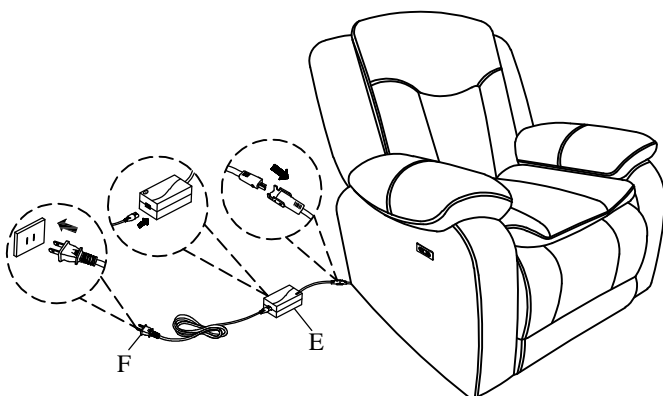

Step 4:

Open the Footrest by pressing the power button on/off.

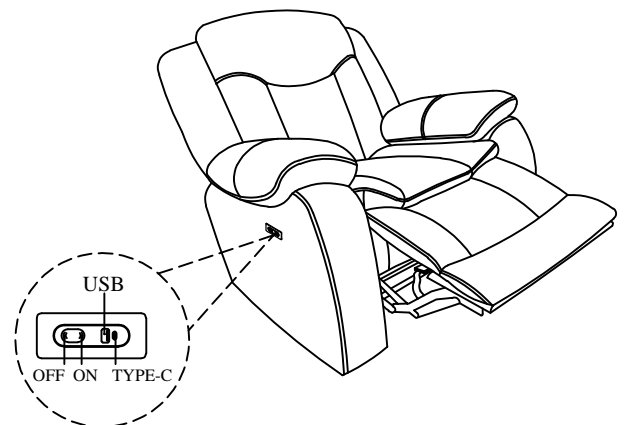

All images shown are for illustration purpose only.
Actual product may vary due to product enhancement.