

Model ST-2459 Series Water Closet Installation Instructions

THE RIGHT CHOICE

We thank you for your purchase. Our products are 100% tested but should you have any questions, please contact us by phone or on our web site.



ST-2459

▲ WARNING: Vitreous china can chip or break if the bolts or nuts are over-tightened or if mishandled.

- Check all local plumbing and building codes.
- Check for any damage to the new water closet before installation.

WHAT YOU WILL NEED...

- Sponge
- Putty knife
- Safety glasses
- Measuring tape
- Spud wrench
- Non-wax Gasket
- 10" adjustable wrench
- Large level
- Carrier Mounting hardware

NOTE: Plumbing System Requirements

- ✓ Minimum Flowing Pressure: 25 PSI
- ✓ Minimum Flow Rate: 18 GPM
- ✓ Maximum Static Pressure: 80 PSI

NOTE: All vitreous china dimensions shown in these drawings are nominal. Dimensions can vary within the tolerances established in the governing ASME A112.19.2/CSA B45.1 standard. Please take this into consideration when planning rough-in and plumbing layouts.

RETROFIT INSTALLATIONS

1. REMOVAL OF EXISTING WATER CLOSET

- Turn off the water supply.
- Disconnect the flush valve.
- Sponge out all remaining water from bowl.
- Cut caulk all around existing bowl using utility knife to release bowl from wall surface.
- Remove the existing water closet.
- Using sharp scraper or putty knife, completely remove all remaining caulk from wall surface.
- Dispose of old gasket.

2. CHECK ROUGH-IN DIMENSIONS

- Check rough-in dimensions and install or relocate flush valve and outlet as indicated.
- A carrier unit is recommended to properly install and support the wall hung water closet. Install carrier unit (not included) per instructions provided by the carrier manufacturer.
- Verify carrier studs are level.

3. CLEAN DRAIN

- Clean out waste pipe using hand or power cleaner to be sure pipe is clear.
- Proceed to NEW INSTALLATIONS.

▲ WARNING: Hazardous gases can escape through the waste pipe if new water closet is not installed quickly. A temporary fix: place a large rag in the waste pipe.

NEW INSTALLATIONS

1. INSTALLING GASKET

- Remove the temporary rag (if used) from the waste pipe hole.
- Lay water closet down on padded surface to help protect the vitreous china.
- Apply gasket to bowl outlet. Refer to the gasket manufacturer's instructions for installation. (Note: wax gaskets of any kind are NOT recommended.)

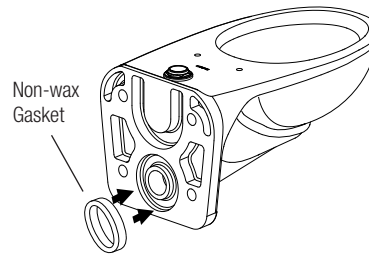

2. INSTALLING WATER CLOSET

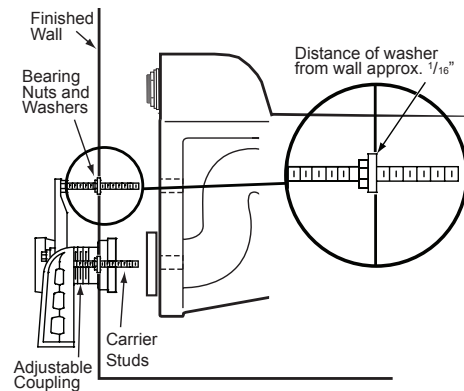

- Determine proper length for carrier studs per carrier's manufacturer.
- Install (3) sets of bearing nuts and washers onto carrier studs: two at the bottom and one on top leaving one top stud blank.
- Bearing nuts and washers must be placed to allow a minimum gap of 1/16" between the wall and fixture. The carrier supports the bowl, not the wall.
- Place level vertically across the top and bottom bearing nuts to ensure they are leveled.
- Adjust carrier coupling to compress gasket for a gas and watertight seal per gasket manufacturer's instructions.

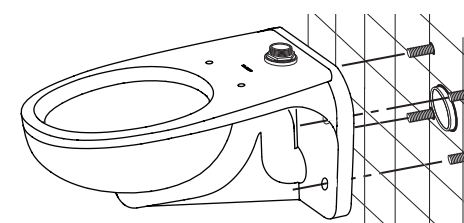

- Place water closet onto the carrier studs.

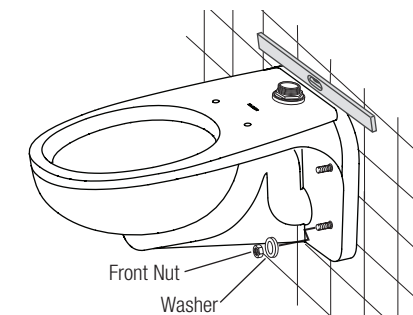

- Loosely attach washers and front nuts on threaded carrier studs.
- Verify water closet is level.
- Hand tighten the (3) nuts that have the bearing nuts behind the water closet.
- Tighten the top nut then bottom nuts alternately while judging the flex of the bowl at the front lip due to the compression of the gasket. Bowl is secure and has adequate seal when no noticeable flex occurs.
- Hand-tighten the last nut and washer, then tighten 1/4-turn using a wrench.

▲ IMPORTANT! Do not overtighten the nuts, breakage and chipping of vitreous china can occur.

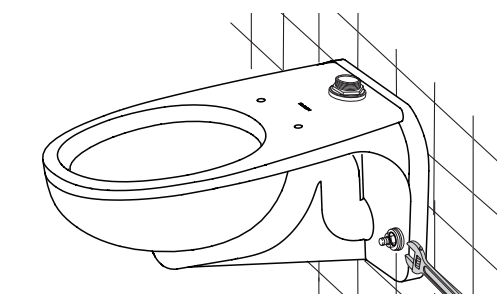

3. COMPLETING THE INSTALLATION

- Flush valve should be installed to manufacturer's installation instructions.

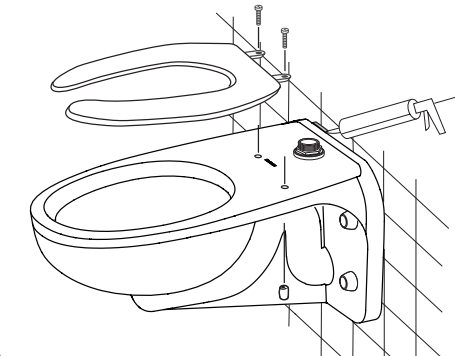

- Turn on water supply valve.
- Install water closet seat.
- Caulk around water closet.
- Flush water closet a few times and check all connections for water seepage.
- Check for leaks for a few days.
- Record model number for reference.

LIMITED WARRANTY

Sloan Valve Company warrants its vitreous china products to be made of first class materials, free from defects of material or workmanship under normal use and to perform the service for which they are intended in a thoroughly reliable and efficient manner when properly installed and serviced, for a period of three years from date of purchase. During this period, Sloan Valve Company will, at its option, repair or replace any part or parts which prove to be thus defective if returned to Sloan Valve Company, at customer's cost, and this shall be the sole remedy available under this warranty. No claims will be allowed for labor, transportation or other incidental costs. This warranty extends only to persons or organizations who purchase Sloan Valve Company's products directly from Sloan Valve Company for purpose of resale.

THERE ARE NO WARRANTIES WHICH EXTEND BEYOND THE DESCRIPTION ON THE FACE HEREOF. IN NO EVENT IS SLOAN VALVE COMPANY RESPONSIBLE FOR ANY CONSEQUENTIAL DAMAGES OF ANY MEASURE WHATSOEVER. NOTE: IN NO EVENT SHALL THE SLOAN VALVE COMPANY BE LIABLE FOR INCIDENTAL DAMAGES, RESULTING FROM IMPROPER INSTALLATION, OR FOR DAMAGES CAUSED BY NEGLIGENCE, ABUSE OR ALTERATION.

TO MAXIMIZE THE PERFORMANCE OF YOUR SLOAN® WATER CLOSET, USE ONLY SLOAN® FLUSHMETERS



SLOAN®

SLOAN VALVE COMPANY

10500 Seymour Avenue
Franklin Park, IL 60131
Phone: 1-800-9-VALVE-9 or 1-847-671-4300
Fax: 1-800-447-8329 or 1-847-671-4380
www.sloanvalve.com

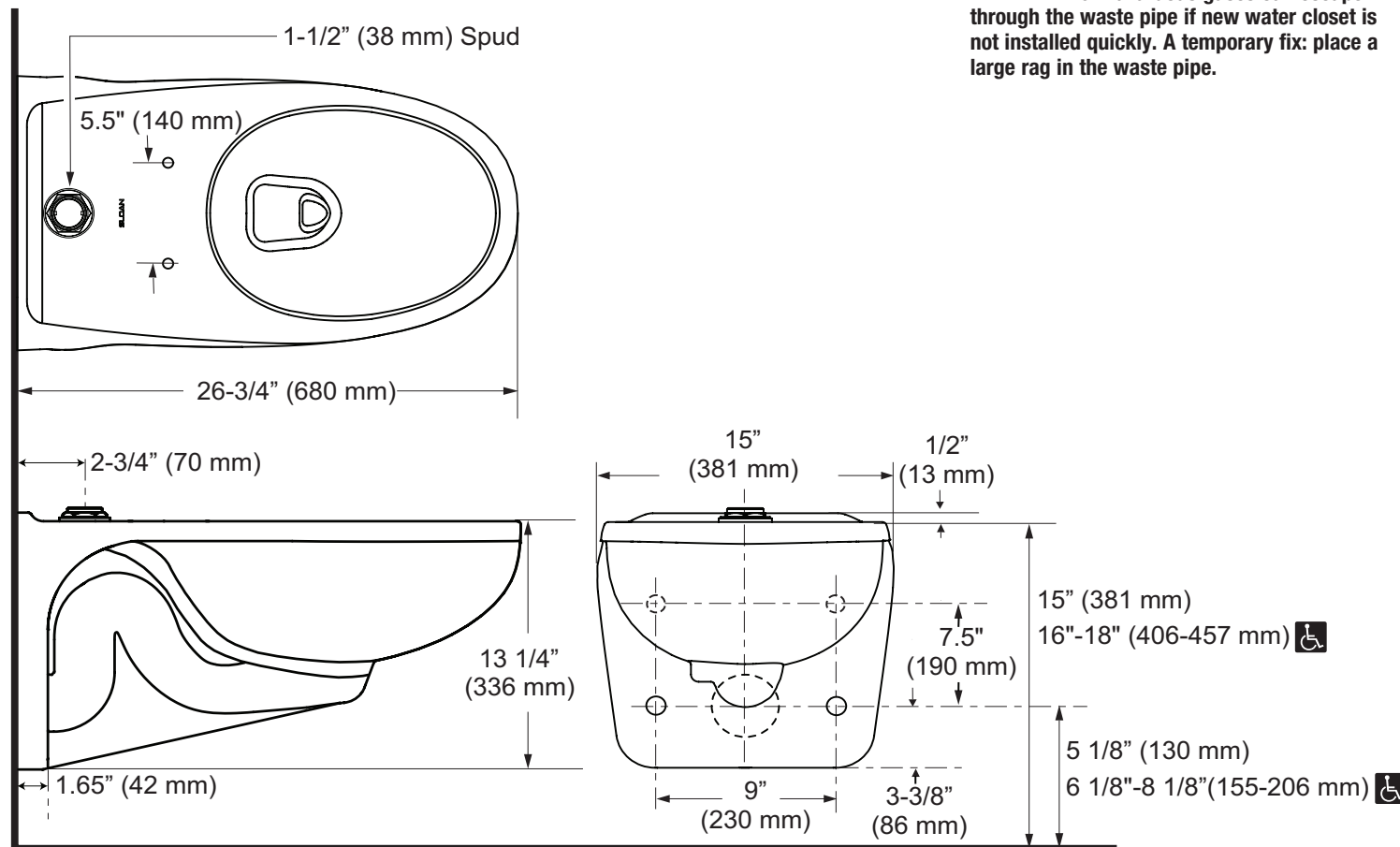

Instalación Instrucciones de Sanitario Modelo Serie ST-2459

LA ELECCIÓN CORRECTA

Le agradecemos su compra. Nuestros productos son probados al 100%, sin embargo, si tiene alguna duda, contáctenos por teléfono o en nuestro sitio web.



ST-2459

⚠ ADVERTENCIA: Cualquier porcelana puede astillarse o romperse si los pernos o tuercas se aprietan de más o si son mal manipulados.

- Revise todos los códigos locales de plomería y construcción.
- Revise si el nuevo sanitario presenta daños antes de instalarlo.

LO QUE USTED NECESITA...

- Espátula para masilla
- Lentes de Seguridad
- Cinta para medir
- Llave para spud
- Empaque sin cera
- Esponja
- Llave ajustable 10"
- Nivel grande
- Cargador y Herrajes de montaje

NOTA: Requerimientos del Sistema de Plomería

✓ Presión Mínima de Flujo: 25 PSI

✓ Caudal Mínimo: 18 GPM

✓ Máxima presión estática: 80 PSI

NOTA: Todas las dimensiones mostradas en estos dibujos son nominales. Las dimensiones pueden variar dentro de las tolerancias establecidas en la norma ASME A112.19.2/CSA B45.1. Por favor tenga esto en cuenta al planificar la preparación y diseños de plomería.

INSTALACIONES DE REEQUIPAMIENTO

1. REMOVER EL SANITARIO EXISTENTE

- Cierre la alimentación de agua.
- Desconecte la válvula de descarga.
- Seque toda el agua remanente en la taza.
- Corte la masilla con el cuchillo multiusos por todo alrededor de la taza existente para soltarla de la superficie.
- Remueva el sanitario existente.
- Usando un raspador afilado o una espátula, remueva completamente la masilla restante de la superficie de la pared.
- Elimine el empaque usado.

2. REVISAR LAS DIMENSIONES DE PREPARACIÓN

- Revise las dimensiones de preparación e instale o mueva la válvula de descarga y salida como se indica
- Se recomienda una unidad portadora para instalar adecuadamente y soportar el sanitario colgado de pared. Instale la unidad portadora (no incluido) de acuerdo con las instrucciones del fabricante de la misma.
- Verifique que los pernos del portador estén nivelados.

3. LIMPIAR EL DESAGÜE

- Limpie el tubo de drenaje con un limpiador manual o eléctrico para asegurarse que quede bien limpio.
- Proceda a INSTALACIONES NUEVAS.

⚠ ADVERTENCIA: Gases peligrosos pueden escapar por la tubería de desagüe si el nuevo sanitario no se instala rápidamente. Una solución temporal: coloque un trozo grande de tela en la tubería de desagüe.

INSTALACIONES NUEVAS

1. INSTALAR EL EMPAQUE

- Remueva el trozo de tela temporal (si se utilizó) del agujero del tubo de drenaje.
- Coloque el sanitario sobre una superficie acolchada para proteger la porcelana.
- Coloque el empaque a la salida de la taza. Consulte su instalación en las instrucciones del fabricante del empaque. (Nota: NO se recomiendan los empaques de cualquier tipo que son totalmente de cera).

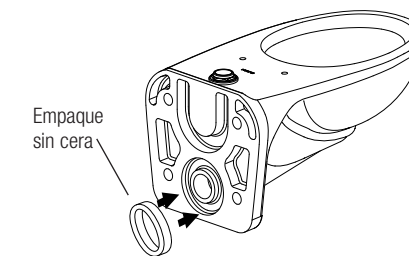

2. INSTALAR EL SANITARIO

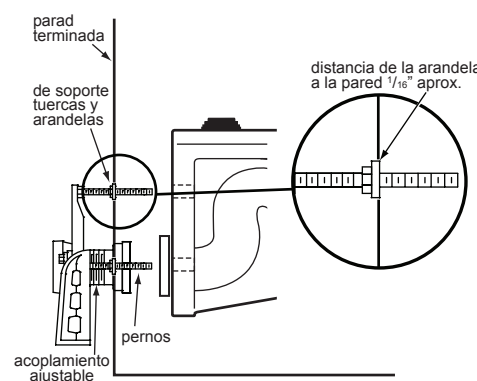

- Determine la longitud necesaria de los pernos de acuerdo a las instrucciones del fabricante del portador.
- Instale (3) juegos de tuercas y arandelas de soporte en los pernos del portador: dos en la parte inferior y en uno de los pernos superiores dejando el otro sin tuerca ni arandela.
- Las tuercas y arandelas de soporte deben ser instaladas garantizando un espacio mínimo de 1.6 mm (1/16") entre el sanitario y la pared. El portador es el que debe soportar el sanitario, no la pared.
- Coloque un nivel sobre las dos tuercas de soporte inferiores y luego sobre la tuerca de soporte superior asegurando que están niveladas.
- Ajuste el acoplamiento del portador para asegurar la adecuada compresión en el empaque para garantizar un buen sello.

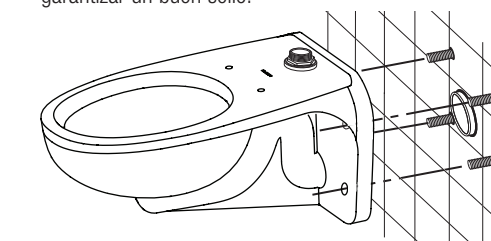

- Coloque el sanitario en los pernos del portador.

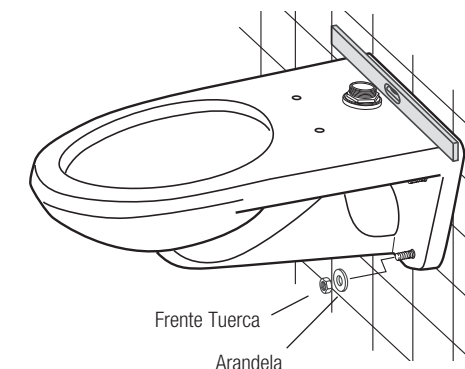

- Coloque flojas las arandelas y tapones roscados en los pernos roscados del portador.
- Verifique que el sanitario esté nivelado.
- Apriete firmemente los (3) tapones roscados y arandelas en los pernos que contienen las tuercas y arandelas de soporte. Luego instale la última arandela y tapón roscado apretando aproximadamente 1/4 de vuelta.

⚠ ¡IMPORTANTE! No apriete de más las tuercas, puede ocurrir ruptura o astillarse la porcelana.

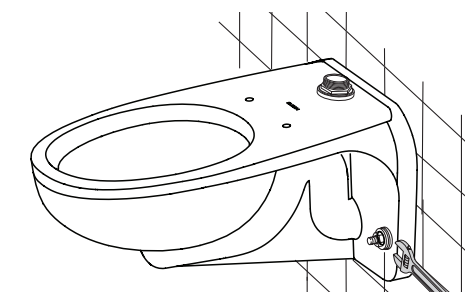

3. TERMINAR LA INSTALACIÓN

- La válvula de descarga debe instalarse de acuerdo con las instrucciones de su fabricante.

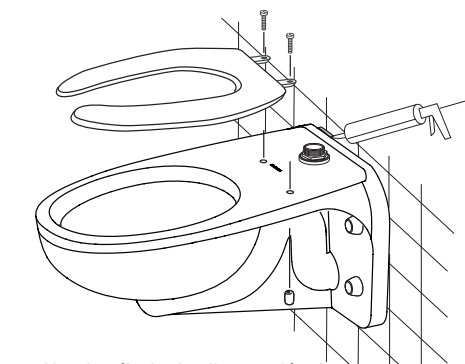

- Abra la válvula de alimentación de agua.
- Instale el asiento del sanitario.
- Coloque masilla alrededor del sanitario.
- Descargue el sanitario varias veces y revise todas las conexiones para ver si presentan filtraciones.
- Revise si hay fugas por varios días.
- Registre el número de modelo como referencia.

GARANTÍA LIMITADA

Sloan Valve Company garantiza que sus productos de porcelana están hechos de materiales de primera clase, libres de defectos en el material o en la fabricación, bajo uso normal y para llevar a cabo el servicio para el cual se han fabricado, en una forma totalmente eficiente y confiable siempre que se instalen adecuadamente y se les dé el servicio adecuado, por un período de tres años a partir de la fecha de compra. Durante este período Sloan, a su discreción, reparará o reemplazará cualquier parte o partes que se comprueben que estén defectuosas si se devuelven a Sloan, a costo del cliente, y este será el único recurso correctivo que se ofrece con esta garantía. No se aceptarán reclamos por mano de obra, transporte u otros costos incidentales. La presente garantía se extiende únicamente a personas u organizaciones que compren los productos de Sloan Valve Company directamente de Sloan Valve Company con fines de reventa.

NO EXISTEN MÁS GARANTÍAS QUE SE EXTIENDAN MAS ALLÁ DE LA QUE SE DESCRIBIÓ ANTERIORMENTE. EN NINGÚN CASO SLOAN VALVE COMPANY ES RESPONSABLE POR CUALQUIER DAÑO CONSECUENTE DE CUALQUIER CLASE.

NOTA: EN NINGÚN CASO SLOAN VALVE COMPANY SERÁ RESPONSABLE POR DAÑOS INCIDENTALES, RESULTADO DE INSTALACIÓN INADECUADA, O POR DAÑOS CAUSADOS POR NEGLIGENCIA, ABUSO O ALTERACIÓN.

PARA MAXIMIZAR EL DESEMPEÑO DE SU SANITARIO SLOAN® USE ÚNICAMENTE FLUXOMETROS SLOAN®



SLOAN®
SLOAN VALVE COMPANY

10500 Seymour Avenue
Franklin Park, IL 60131
Tel: 1-800-9-VALVE-9 o 1-847-671-4300
Fax: 1-800-447-8329 o 1-847-671-4380
www.sloanvalve.com

Copyright © 2015 Sloan Valve Company
No. Código: 0816652 Rev.1 09-15

INSTALLATION INSTRUCTIONS FOR RETROFIT AND COMPLETE VALVE INSTALLATION FOR SLOAN SOLIS®, SOLAR POWERED, SINGLE FLUSH AND DUAL FLUSH WATER CLOSETS AND URINALS



8100 Series Complete Flushometer Models

8100 Series Sloan SOLIS® valves are complete flushometers and ideal for new installations.



RESS Series Retrofit Conversion Kit Models

RESS Sloan SOLIS® Models are used to convert existing Flushometers to Solar Powered, Sensor Activated.

Sloan SOLIS® Water Closet Models can be furnished for the following:

1.1 gpf / 4.2 Lpf	High Efficiency Bowls
1.28 gpf/4.8 Lpf	High Efficiency Bowls
1.6 gpf/6.0 Lpf	For Low Consumption Bowls
1.6 / 1.1 gpf (6.0 / 4.2 Lpf)	Dual Flush Models

Sloan SOLIS® Urinal Models can be furnished for the following:

0.125 gpf/0.5 Lpf	For High Efficiency Urinals
0.25 gpf/0.9 Lpf	For High Efficiency Urinals
0.5 gpf/1.9Lpf	For High Efficiency Urinals
1.0 gpf/3.8 Lpf	For Low Consumption Urinals
1.5 gpf/5.7 Lpf	For Older Siphon Jet Urinals



SLOAN® LIMITED WARRANTY SUMMARY

Sloan Valve Company ("Sloan"), warrants its products against defects in materials and workmanship, excluding damage caused by matters beyond Sloan's reasonable control. Instructions for filing claims can be found in the Limited Warranty which can be obtained at www.sloan.com or by requesting a free copy by telephone at 888.756.2614. Sloan will repair or replace your defective product, or provide a refund, as your exclusive remedy. This is only a general summary of Sloan's Limited Warranty so it is important to note that the specific terms, conditions, limitations and exclusions, including the duration of warranty coverage for your particular Sloan product, are contained in the actual Sloan Limited Warranty. The Limited Warranty is subject to applicable laws in your country, state, province or other jurisdiction—and disputes arising under the Limited Warranty are to be resolved by binding arbitration unless you provide Sloan with an opt-out notice no later than 30 days after your purchase date. In case of a conflict with this summary, the terms and conditions set forth in the complete Limited Warranty will prevail.

PRIOR TO INSTALLING THE SLOAN SOLIS® FLUSHOMETER

Please take the time to read this manual to ensure proper product installation and longevity. Also, please visit our website to download our most recent documentation for this product.

Prior to installing the Sloan SOLIS® flushometer, install the items listed below as illustrated in the rough-in diagram. (New installations only.)

- Closet or Urinal fixture
- Drain line
- Water supply line

IMPORTANT:

- **INSTALL ALL PLUMBING IN ACCORDANCE WITH APPLICABLE CODES AND REGULATIONS.**
- **WATER SUPPLY LINES MUST BE SIZED TO PROVIDE AN ADEQUATE VOLUME OF WATER FOR EACH FIXTURE.**

- **WHEN INSTALLING A FLUSHOMETER, IT IS IMPORTANT THAT THE FLUSH MODEL MATCHES THE REQUIREMENTS OF THE PLUMBING FIXTURE.**
- **FLUSH ALL WATER LINES PRIOR TO MAKING CONNECTIONS.**

The Sloan SOLIS® is designed to operate with 15 to 80 PSI (104 to 551 kPa) of water pressure. **THE MINIMUM PRESSURE REQUIRED TO THE VALVE IS DETERMINED BY THE TYPE OF FIXTURE SELECTED.** Consult fixture manufacturer for pressure requirements.

Most water closets (1.6 gallon/6 liter or lower) require a minimum flowing pressure of 25 psi (172 kPa); some manufacturers require a higher minimum flowing pressure.

TOOLS REQUIRED FOR INSTALLATION

- Slotted screwdriver to adjust control stop.
- Sloan A-50 Super-Wrench™, Sloan A-109 Plier Wrench or smooth jawed spud wrench for couplings.
- Strap wrench (supplied) to install Sloan SOLIS® to valve body.
- 7/64" hex wrench (supplied) to secure Sloan SOLIS® cover to base plate.
- 5/64" hex wrench to secure water Supply Flange.

VALVE ROUGH-IN

WATER CLOSET INSTALLATION

Models 8111, 8113, 8115, 8116
Reference for RESS-C Retrofit

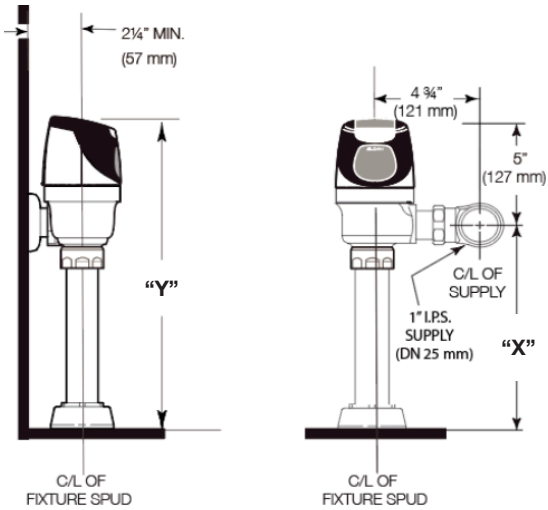

TYPICAL URINAL INSTALLATION

Models 8180 & 8186
Reference for RESS-U Retrofit

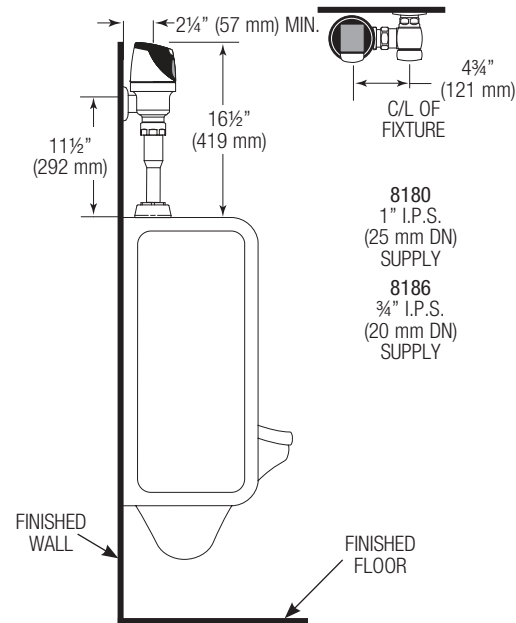

FOR ADA GRAB BAR APPLICATIONS

For ADA grab Bar at 36", use 10" rough-in height or use H-1018-A Offset Adapter. See the *Alternative Water Closet Installation* section below for additional information.

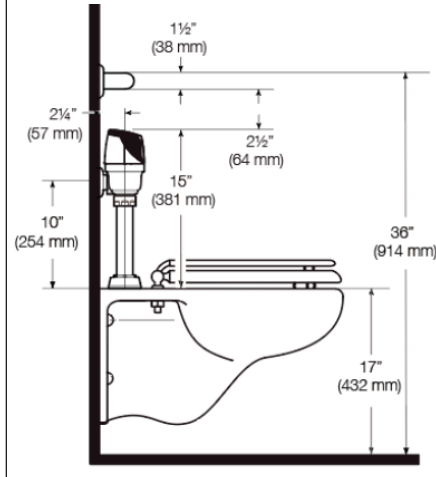

Model	"X"	"Y"
8111†	11½" (292 mm)	16½" (419 mm)
8113	16" (406 mm)	21" (533 mm)
8115‡	24" (610 mm)	29" (737 mm)
8116‡	27" (686 mm)	32" (813 mm)

† For new installations, Sloan strongly recommends the use of our Model 8111 which has a shorter installation height.

‡ Model 8115 & 8116 valves are designed for installations where the water supply is roughed-in 24" - 27" (610 mm - 686 mm) above the top of the water closet.

!!! IMPORTANT !!!

PROTECT THE CHROME OR SPECIAL FINISH OF FLUSHOMETERS – DO NOT USE TOOTHED TOOLS TO INSTALL OR SERVICE THESE VALVES. USE A SLOAN A-50 SUPER-WRENCH™, SLOAN A-109 PLIER WRENCH OR SMOOTH JAWED SPUD WRENCH TO SECURE ALL COUPLINGS. ALSO SEE "CARE AND CLEANING" SECTION.

NOTE

Maximum adjustment of the Sloan Adjustable Tailpiece is ½" (13 mm) IN or OUT from the standard 4¾" (121 mm) (*centerline of Flushometer to centerline of Control Stop*).

If roughing-in measurement exceeds 5¼" (133 mm), consult factory for longer tailpiece.

!!! IMPORTANT !!!

LAWS AND REGULATIONS PROHIBIT THE USE OF HIGHER FLUSHING VOLUMES THAN LISTED ON FIXTURE OR FLUSHOMETER.

THE STRAP WRENCH PROVIDED WITH THE SOLIS® IS A CONVENIENCE TOOL AND IS NOT TO BE USED TO REMOVE OR INSTALL THE FLUSHOMETER COUPLINGS. USE STRAP WRENCH ONLY TO INSTALL THE SOLIS® LOCKING RING.

WITH THE EXCEPTION OF THE CONTROL STOP INLET, DO NOT USE PIPE SEALANT OR PLUMBING GREASE ON ANY VALVE COMPONENT OR COUPLING!

THIS PRODUCT CONTAINS MECHANICAL AND/OR ELECTRICAL COMPONENTS THAT ARE SUBJECT TO NORMAL WEAR. THESE COMPONENTS SHOULD BE CHECKED ON A REGULAR BASIS AND REPLACED AS NEEDED TO MAINTAIN THE VALVE'S PERFORMANCE.

NEVER OPEN CONTROL STOP TO WHERE THE FLOW FROM THE VALVE EXCEEDS THE FLOW CAPABILITY OF THE FIXTURE. IN THE EVENT OF A VALVE FAILURE, THE FIXTURE MUST BE ABLE TO ACCOMMODATE A CONTINUOUS FLOW FROM THE VALVE.

If you have questions about how to install your Sloan flushometer, consult your local Sloan Representative, or contact Sloan Technical Support at 1.888.SLOAN.14 (1.888.756.2614).

ALTERNATIVE WATER CLOSET INSTALLATION WITH GRAB BAR

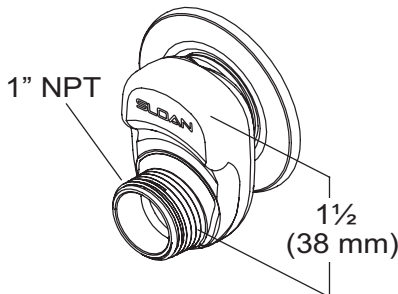

When installing the Sloan SOLIS® Electronic Flushometer in an ADA compliant stall: Per ADA Guidelines (section 604.9.4) it is recommended that the grab bars be split or shifted to the wide side of the stall. For alternative installations, lower water supply rough-in to 10" (254 mm), or use the H-1018-A 1-1/2" offset adapter (not supplied) to lower the overall height. The Sloan H-1018-A 1" NPT x 1-1/2" offset adapter kit (sold separately) is designed to lower a SOLIS® Flushometer 1-1/2" when the space above the top of the Flushometer conflicts with grab bar clearance. Mount the grab bar at the 36" (914 mm) maximum allowed height (top of grab bar at 36").

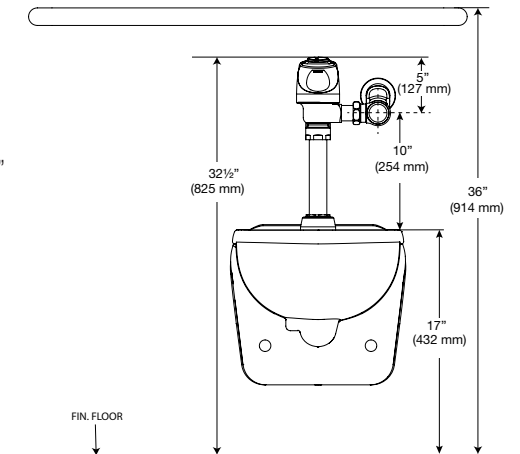

1 - FOR COMPLETE VALVE INSTALLATION, START HERE. FOR RESS RETROFIT INSTALLATIONS, START AT STEP 6. INSTALL OPTIONAL SWEAT SOLDER ADAPTER (ONLY IF YOUR SUPPLY PIPE DOES NOT HAVE A MALE THREAD)

- A** Measure from finished wall to C/L of Fixture Spud. Cut pipe 1 1/4" (32 mm) shorter than this measurement. Chamfer O.D. and I.D. of water supply pipe.
- B** Slide Threaded Adapter fully onto pipe.
- C** Sweat solder the Adapter to pipe.

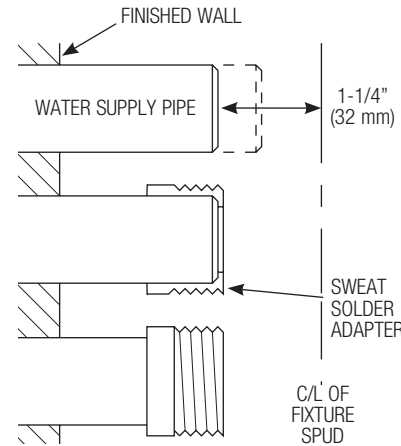

NOTE: Use only Sloan sweat adapter fully inserted onto pipe.

!!! IMPORTANT !!!
WITH THE EXCEPTION OF THE CONTROL STOP INLET, DO NOT USE PIPE SEALANT OR PLUMBING GREASE ON ANY VALVE COMPONENT OR COUPLING!

2 - INSTALL COVER TUBE, WALL FLANGE AND CONTROL STOP TO SUPPLY PIPE

- A** Measure from finished wall to first thread of adapter or threaded supply pipe (dimension "X"). Cut cover tube to this length.
- B** Slide cover tube over pipe. Slide wall flange over cover tube until against wall.

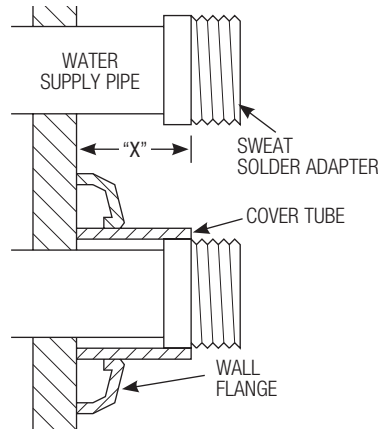

- C** Thread control stop onto pipe. Tighten with a wrench.
- D** Tighten set screw with a 5/64" hex wrench. DO NOT install vandal resistant stop cap at this time.

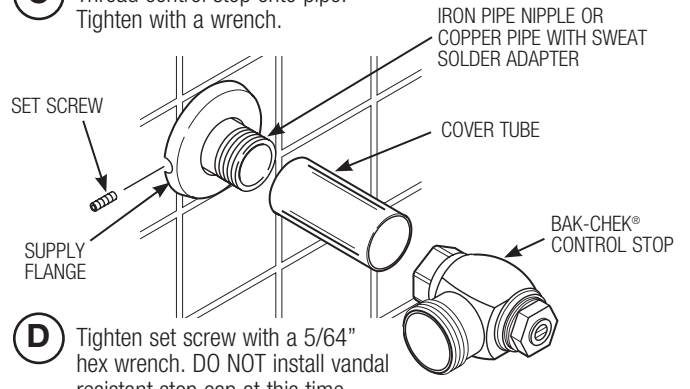

3 - FLUSH OUT SUPPLY LINE

- A** Open Control Stop.

CLOCKWISE CLOSSES CONTROL STOP
COUNTERCLOCKWISE OPENS CONTROL STOP

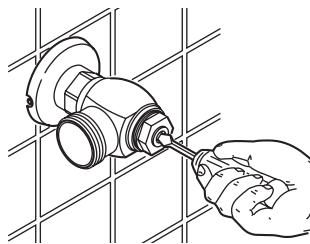

- B** Turn on water supply to flush line of any debris or sediment.
- C** Close control stop.

4 - INSTALL VACUUM BREAKER FLUSH CONNECTION

NOTE
 If cutting Vacuum Breaker Tube to size, note that Critical Line (C/L) on Vacuum Breaker must typically be 6" (152 mm) above fixture. Consult Code for details.

- A** Slide Spud Coupling, Nylon Slip Gasket, Rubber Gasket and Spud Flange over Vacuum Breaker Tube.
- B** Insert Tube into Fixture Spud.
- C** Hand tighten Spud Coupling onto Fixture Spud.

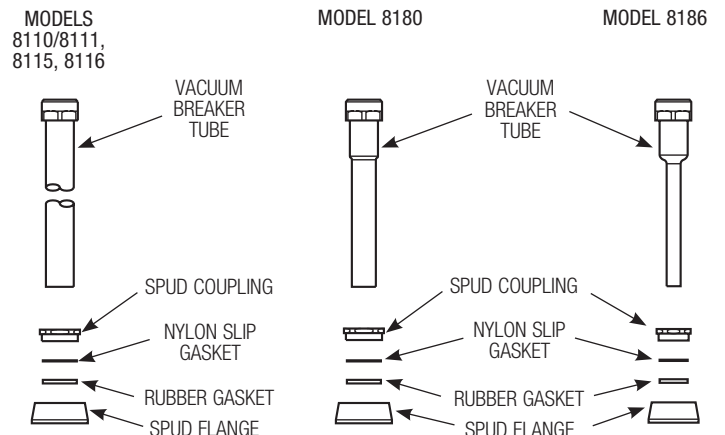

5 - INSTALL FLUSHOMETER

- A** Lubricate tailpiece o-ring with water. Insert adjustable tailpiece into control stop. Tighten tailpiece coupling by hand.
- B** Align flushometer directly above the vacuum breaker flush connection by sliding the flushometer body IN or OUT as needed. Tighten vacuum breaker coupling by hand.
- C** Align flushometer body and securely tighten first the tailpiece coupling (1), then the vacuum breaker coupling (2), and finally the spud coupling (3). Use a wrench to tighten these couplings in the order shown.

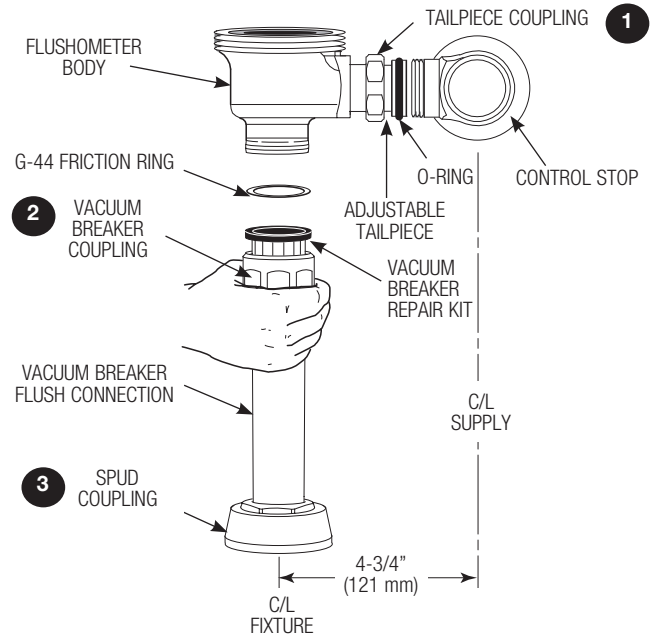

NOTE

Maximum adjustment of the Sloan Adjustable Tailpiece is $\frac{1}{2}$ " (13 mm) IN or OUT from the standard $4\frac{3}{4}$ " (121 mm) (centerline of Flushometer to centerline of Control Stop).

If roughing-in measurement exceeds $5\frac{1}{4}$ " (133 mm), consult factory for longer tailpiece.

6 - WHEN RETROFITTING AN EXISTING VALVE, START HERE. REMOVE COMPONENTS FROM EXISTING FLUSHOMETER (RESS RETROFIT INSTALLATIONS ONLY)

- A** Remove control stop cap.
- B** Turn off water supply at control stop. Push valve handle to relieve water pressure.
- C** Remove outside and inside covers and old inside parts kit.
- D** Remove old handle assembly and gasket.
- E** Install chrome handle cap with gasket to handle opening on flushometer body. Tighten chrome handle cap securely.

RESS SERIES INSTALLATIONS ONLY

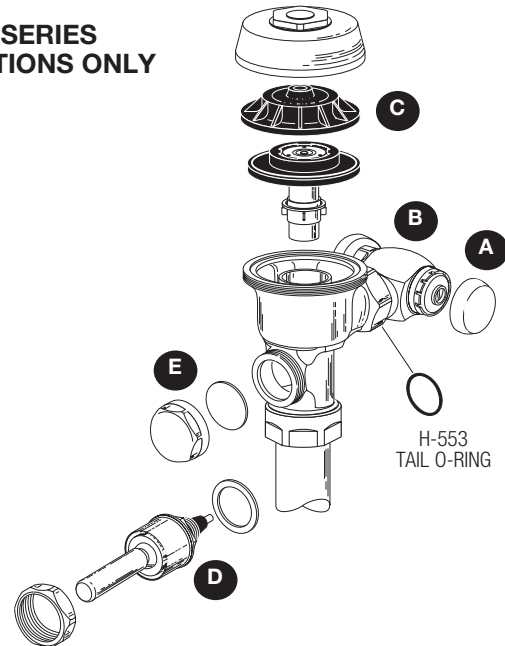

NOTE: An extra H-553 tail o-ring is included (in the bag with the handle cap and gasket) in the event leakage occurs if the valve is repositioned during the installation of the new SOLIS®. Use only as needed.

7 - SLOAN SOLIS® FLUSH VOLUME (RESS RETROFIT INSTALLATIONS ONLY)

The flush volume of the Sloan SOLIS® is controlled by the Regulator in the flex tube diaphragm Kit. Regulators are identified by color.

When installing a new Regulator on a Flex Tube Diaphragm, be sure to push the Regulator past the O-ring when installing.

NOTE: Never use more water than needed. Low Consumption water closets and urinals will not function properly on excess water.

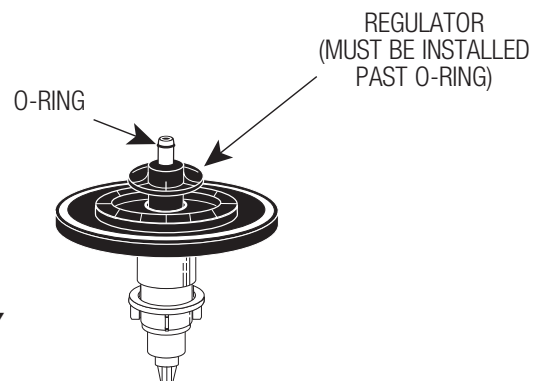

RESS SERIES INSTALLATIONS ONLY

8 - ASSEMBLE FLEX TUBE DIAPHRAGM TO SOLIS ASSEMBLY

- A** Make sure Flush Volume Regulator is installed past O-ring.

For SOLIS -SMT:
Document the serial number and token number on the label at the back of the SOLIS assembly by taking a photo or writing it down.

Serial # SRS-XXXXXXXXXXXX
Token # XXXXXXXXXXXX

IMPORTANT: Please note location and restroom for each serial number for future importing to SC Argus Pro.

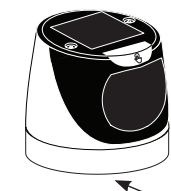

- B** Insert diaphragm into the base of the Sloan SOLIS® Assembly. O-ring must be fully inserted into the hole.

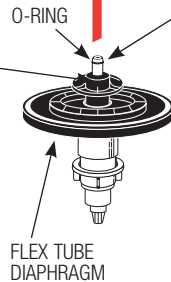

- C** Push diaphragm securely against underside of Sloan SOLIS® Assembly. Place entire Assembly onto the Valve Body.

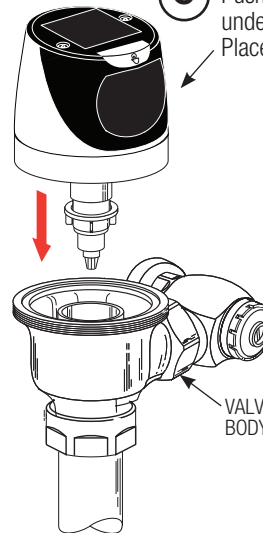

To facilitate installation, wet the diaphragm assembly (on top or completely).

NOTE: Sensor Lens must face directly forward. Rotating the Sensor to either side will decrease the Sensor's ability to detect a target.

9 - TIGHTEN LOCKING RING

- A** Thread Locking Ring onto Valve Body.

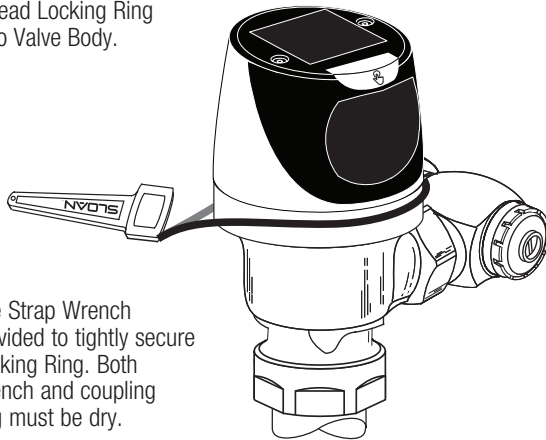

- B** Use Strap Wrench provided to tightly secure Locking Ring. Both wrench and coupling ring must be dry.

!!! IMPORTANT !!!

THE LOCKING RING MUST BE INSTALLED DOWN PAST THE VALVE BODY THREADS BY AT LEAST ONE THREAD. IF DIFFICULTY IS EXPERIENCED INSTALLING THE LOCKING RING, TURN THE LOCKING RING BACK AND FORTH, EACH TIME WORKING IT FURTHER DOWN THE THREADS. THE LOCKING RING WILL ACT AS A THREAD CHASER IN THE EVENT THERE HAS BEEN A BUILD-UP OF MATTER ON THE THREADS OF THE OLD VALVE BODY.

If retrofitting the Sloan SOLIS® onto a †Zurn® valve body, a special Locking Ring must be used (identified by a machined groove around the ring). Order the Sloan SOLIS® with the "Z" variation to receive the unit supplied with this Ring.

10 - REMOVE TAPE FROM SOLAR PANEL AND SENSOR WINDOW TO ACTIVATE

- A** Remove the tape located over solar panel.

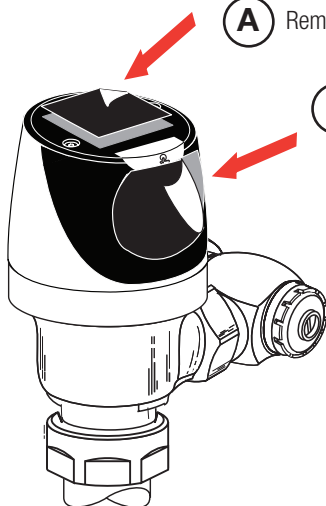

- B** Remove the tape located over sensor window.

- C** Stand clear from the sensor for (1) minute to allow the unit to start-up and calibrate to the installed environment.

- D** For the first ten (10) minutes of operation, a visible light flashes in the sensing window of the SOLIS® flushometer when a user is detected.

!!! IMPORTANT !!!

The start-up routine will be 1 minute long and allows the sensors to adapt to the surrounding environment. It is **VERY IMPORTANT** that no non-permanent targets (i.e. persons, buckets, covers, etc) are present at this time. The start-up routine consists of a long (3 seconds) BLUE light ON, followed by slow BLUE light blinking in for 1 minute. At the end of the routine the sensor will show ONE long (2 seconds) BLUE light ON for lithium battery or TWO long (2 seconds each) BLUE light ON pulses for alkaline to complete the routine. Only at this time can the non-permanent objects be present.

† The brands and/or products names referenced herein may be subject to trademark rights of their respective owners. Use of the brands and names is for identification purposes only and does not imply affiliation with or endorsement by Sloan.

11 - TEST SENSOR OPERATION

The Sloan SOLIS® has a factory set sensing range:
 Water Closet Models - 22" to 42" (559 mm to 1067 mm)
 Urinal Models - 15" to 30" (381 mm to 762 mm)

THE FACTORY SETTING SHOULD BE SATISFACTORY FOR MOST INSTALLATIONS. IF A RANGE ADJUSTMENT IS REQUIRED, REFER TO THE RANGE ADJUSTMENT INSTRUCTIONS.

A Test Sensor with Cover in place.

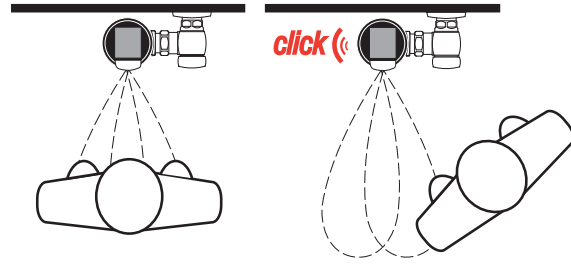

B Stand in front of Sensor for sixteen (16) seconds

C Step away from Sensor and listen for "CLICK."

12 - ADJUST CONTROL STOP AND INSTALL VANDAL RESISTANT STOP CAP

A Open control Stop COUNTERCLOCKWISE at least ½ turn from closed position.

B Activate flushometer by placing hand in front of Sloan SOLIS® Sensor Lens for ten (16) seconds (or press override button) and then moving it away.

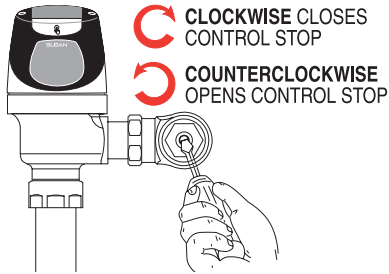

C Adjust control stop after each flush until the rate of flow delivered properly cleanses the fixture.

D Install control stop cap onto control stop. For RESS retrofit applications, reuse stop cap from existing valve. In complete valve installations, a new stop cap is provided. Follow the instructions packaged with the free spinning vandal resistant stop cap.

!!! IMPORTANT !!!
 SLOAN FLUSHOMETERS ARE ENGINEERED FOR QUIET OPERATION. EXCESSIVE WATER FLOW CREATES NOISE, WHILE TOO LITTLE WATER FLOW MAY NOT SATISFY THE NEEDS OF THE FIXTURE. PROPER ADJUSTMENT IS MADE WHEN PLUMBING FIXTURE IS CLEANSED AFTER EACH FLUSH WITHOUT SPLASHING WATER OUT FROM THE LIP AND A QUIET FLUSHING CYCLE IS ACHIEVED.

!!! IMPORTANT !!!
 THE CONTROL STOP SHOULD NEVER BE OPENED TO THE POINT WHERE THE FLOW FROM THE VALVE EXCEEDS THE FLOW CAPABILITY OF THE FIXTURE. IN THE EVENT OF A VALVE FAILURE, THE FIXTURE MUST BE ABLE TO ACCOMMODATE A CONTINUOUS FLOW FROM THE VALVE.

OPERATION

1. A continuous, INVISIBLE light beam is emitted from the Sloan SOLIS® sensor.
2. As the user enters the beam's effective range, 22 to 42 inches (559 mm to 1067 mm) for closet installations and 15 to 30 inches (381 mm to 762 mm) for urinal installations, the beam is reflected into the Scanner Window to activate the Output Circuit. Once activated, the Output Circuit continues in a "hold" mode for as long as the user remains within the effective range of the sensor. For Dual Flush models, if the user stays longer than 65 seconds, a full flush will automatically initiate when the user leaves. For Single Flush models, once the user steps away, a full flush will automatically initiate.
3. For Dual Flush models, once a user is detected, if the user leaves in 65 seconds or less, a reduced flush will automatically initiate. The circuit automatically resets and is ready for the next user. For Single Flush models, when the user steps away, this initiates a full flush. The circuit automatically resets and is ready for the next user.
4. In addition to the above the Sloan SOLIS® urinal incorporates a standard deferred flushing mode feature that accommodates the high volume usage seen in stadiums or similar high attendance facilities.

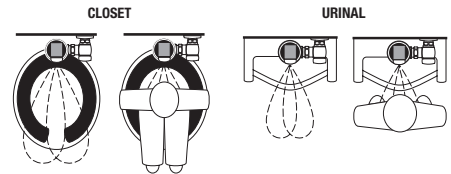

BATTERY REPLACEMENT

When required, replace batteries with four (4) new AA-Size batteries.

NOTE: Water does not have to be turned off to replace batteries.

Loosen the two (2) Screws on top of unit. Remove the complete cover assembly. Lift the sensor module from its plate. Unplug the solenoid connector from battery compartment cover. Loosen the retaining screw on battery compartment cover. Remove battery compartment cover and old batteries.

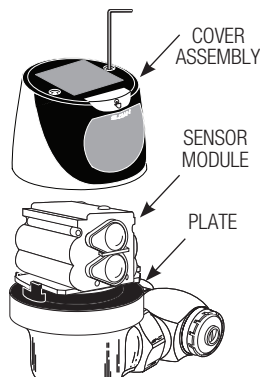

Install four (4) new AA-Size batteries exactly as illustrated. Install battery compartment cover and secure with retaining screw. Make certain that battery compartment cover is fully compressed against gasket to provide a seal; DO NOT overtighten. Plug the solenoid connector into the battery compartment cover. Reinstall the sensor module onto the Plate. Reinstall the complete cover assembly onto the plate. Tighten the two (2) screws on top of the unit.

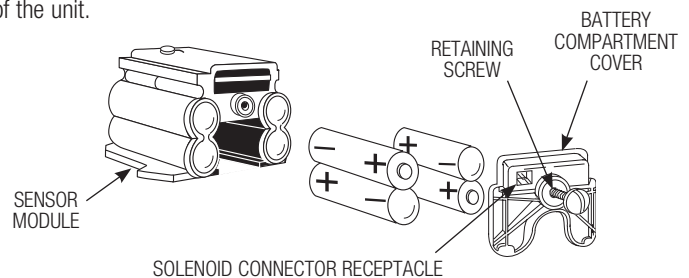

!!! IMPORTANT !!!
 NEVER INSTALL MIXED BATTERY TYPES: (CARBON-ALKALINE-LITHIUM) PRIMARY AND SECONDARY CELLS (NON-RECHARGEABLE VS RECHARGEABLE). REPLACE ALL 4 BATTERIES AT THE SAME TIME WITH FRESH BATTERIES. FAILURE ON THE ABOVE CAN REDUCE BATTERY LIFE, CAUSE BATTERY LEAKAGE, AND RESULT IN PRODUCT DAMAGE.

RANGE ADJUSTMENT (ADJUST ONLY IF NECESSARY)

The Sloan SOLIS® has a factory set sensing range:

Water Closet Models - 22" to 42" (559 mm to 1067 mm)

Urinal Models - 15" to 30" (381 mm to 762 mm)

The factory setting should be satisfactory for most installations.

NOTE: Water DOES NOT have to be turned off to adjust range.

RANGE ADJUSTMENT PROCEDURE

For the first ten (10) minutes of operation, a visible light flashes in the sensing Window of the Sloan SOLIS® flushometer when a user is detected. This visible light feature can be reactivated after ten (10) minutes by opening and closing the battery compartment door. Check the range by stepping toward the unit until the light flashes, indicating the sensor's maximum detection limit.

Always Determine the Sensing Range with Metal Cover and Lens Window On Top of the Unit.

To recalibrate the sensor, touch and hold the override button for 30 seconds, once the Blue LED blinks every second, and release. Stand at desired distance, LED should blink once every 2 seconds for 30 seconds). The setting mode will run for one (1) minute.

NOTE: For -BT models only, to automatically check battery strength, troubleshoot, diagnose and report flushometer issues with a wireless device, use the Sloan Connect APP. The APP is available free-of-charge at the Apple iPhone APP store for iOS devices or the Google Play APP store for Android devices. For more information about the APP and its capabilities please visit www.sloan.com.

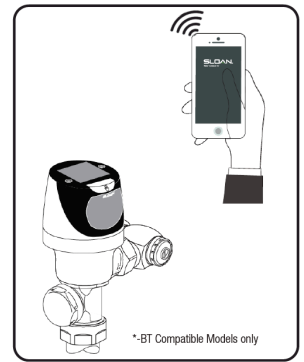

CARE AND CLEANING

DO NOT USE abrasive or chemical cleaners to clean flushometers as they may dull the luster and attack the chrome or special decorative finishes. Use **ONLY** mild soap and water, then wipe dry with clean cloth or towel. **DO NOT** spray cleaner directly onto the flushometer; instead, spray into a clean cloth and then wipe down the flushometer. While cleaning the bathroom tile, the flushometer should be protected from any splattering of cleaner. Acids and cleaning fluids can discolor or remove chrome plating.

TROUBLESHOOTING GUIDE

-SMT models require SC Argus Portal equipment and subscription. Please contact your SC Argus Pro Sales Representative or Sloan Technical Support. For Troubleshooting and Replacement of SOLIS -SMT units, please consult the SOLIS Repair Parts & Maintenance Guide.

1. Sensor Flashes Continuously Only When User Steps Within Range.

- A. Unit in Start-Up mode; no problem. This feature is active for the first ten (10) minutes of operation.

2. Valve Does Not Flush; Sensor Not Picking Up User.

- A. Range too short; increase the range.

3. Valve Does Not Flush; Sensor Picking Up Opposite Wall or Surface, or Only Flushes When Someone Walks By. Light Flashes Continuously for First 10 Minutes Even with No One in Front of the Sensor.

- A. Range too long; shorten range.

4. Valve Does Not Flush Even After Adjustment.

- A. Range Adjustment Potentiometer set at full "max" or full "min" setting. Re-adjust Potentiometer away from full "max" or "min" setting.
- B. Batteries completely used up; replace batteries.
- C. Problem with Electronic Sensor Module; replace Electronic Sensor Module. Try swapping module with working unit to test module function.
- D. Are there audible clicks from the solenoid?

NO: check for solenoid plugged into module; possibly solenoid stuck in closed position, replace solenoid.

YES: check solenoid for over-tightening, check to make sure locking ring was secured properly.

- E. Module is working, and solenoid clicking, loosen and re-tighten locking ring; check diaphragm for perforations in diaphragm disc; replace.

5. Unit Flashes 4 Quick Times When User Steps Within Range.

- A. Batteries low; replace batteries.

!!! IMPORTANT !!!

WHEN SERVICING SOLENOID, ROTATING LOCKING RING, SERVICING DIAPHRAGM, SERVICING VACUUM BREAKER OR SPUD, TURN OFF WATER SUPPLY AT STOP.

!!! IMPORTANT !!!

LAWS AND REGULATIONS PROHIBIT THE USE OF HIGHER FLUSHING VOLUMES THAN LISTED ON FIXTURE OR FLUSHOMETER.

!!! IMPORTANT !!!

MORE FREQUENT ROUTINE MAINTENANCE MAY BE REQUIRED OF THE FLUSHOMETER DUE TO THE CHEMICAL PROPERTIES OF RECLAIMED WATER.

6. Valve Does Not Shut Off.

- A. Bypass Orifice in Diaphragm is clogged with dirt or debris, or Bypass is clogged by an invisible gelatinous film due to "over-treated" water. Remove flex tube diaphragm and wash under running water or replace.

NOTE: SIZE OF ORIFICE IN THE BYPASS IS OF UTMOST IMPORTANCE FOR THE PROPER METERING OF WATER BY THE VALVE. DO NOT ENLARGE OR DAMAGE THIS ORIFICE. REPLACE FLEX TUBE DIAPHRAGM IF CLEANING DOES NOT CORRECT THE PROBLEM.

- B. Dirt or debris fouling stem or flex tube diaphragm. Remove flex tube diaphragm and wash under running water or replace.
- C. O-ring on stem of flex tube diaphragm is damaged or worn. Replace O-ring if necessary EBV-83 O-Ring 1/8 X 1/4 X 1/16 (5325056).
- D. Problem with electronic sensor module; replace sensor module. Try swapping module with working unit to test module function.
- E. Are there audible clicks from the solenoid?

NO, possibly solenoid stuck open position, replace solenoid.

YES, check solenoid properly screwed into inside cover, check to make sure locking ring was secured properly.

- F. If module is working, and solenoid clicking, check diaphragm for perforations in diaphragm disc; replace.

7. Not Enough Water to Fixture.

- A. Wrong flush volume regulator installed in flex tube diaphragm kit. Install the correct Regulator.
- B. Wrong SOLIS® model installed; i.e., 1.0 gpf urinal installed on 3.5 gpf closet fixture. Replace with proper Sloan SOLIS® model.
- C. Enlarged by-pass in diaphragm. Replace flex tube diaphragm.
- D. Control Stop not adjusted properly. Readjust control stop.
- E. Inadequate volume or pressure at supply. Increase water pressure or supply (flow) to valve. Consult factory for assistance.

8. Too Much Water to Fixture.

- A. Wrong flush volume regulator installed in flex tube diaphragm Kit. Install the correct regulator.
- B. Control Stop not adjusted properly. Readjust Control Stop.
- C. Wrong Sloan SOLIS® model installed; i.e., 3.5 gpf Model installed on 1.0 or 1.5 gal. Urinal fixture. Replace with proper Sloan SOLIS® model.
- D. Dirt in Diaphragm Bypass. Clean under running water or replace Flex Tube Diaphragm.

NOTE: Troubleshooting also applies to the Sloan SOLIS Urinals.

PARTS LIST

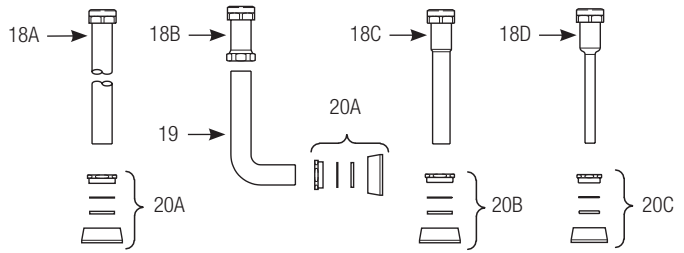
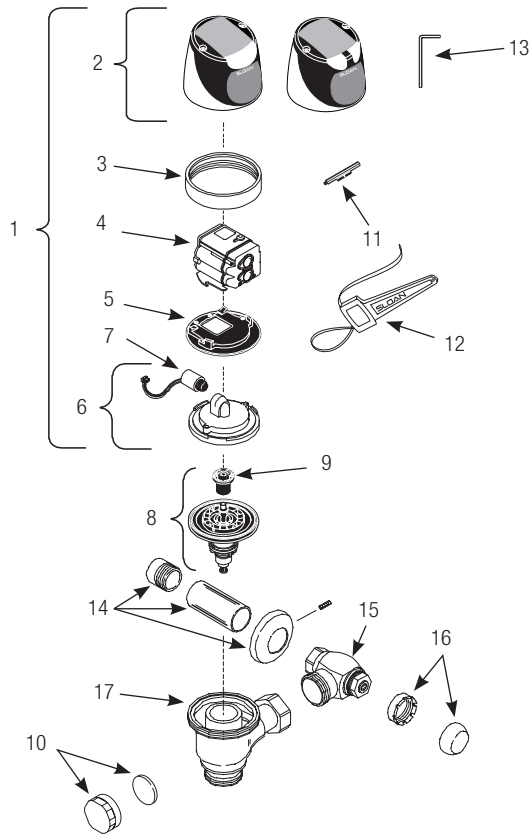

FLEX TUBE DIAPHRAGM ASSEMBLY (#8)

Sloan SOLIS® valve models feature Sloan's exclusive flex tube diaphragm for the ultimate in valve performance, reliability and chloramines resistance.

FCC INFORMATION TO USERS

This equipment has been tested and found to comply with the limits for a class B digital devices, pursuant to Part 15 of the FCC Rules. These limits are designed to provide reasonable protection against harmful interference in a residential installation. This equipment generates, uses, and can radiate radio frequency energy and, if not installed and used in accordance with the instruction manual, may cause harmful interference to radio or television reception, which can be determined by turning the equipment off and on, the user is encouraged to try to correct the interference by one or more of the following measures:

- Reorient or relocate the receiving antenna
- Increase the separation between the equipment and receiver
- Connect the equipment into an outlet on a circuit different from that to which the receiver is connected
- Consult the dealer or an experienced radio/TV technician for help

ITEM #	PART #	DESCRIPTION
--------	--------	-------------

Items Included with RESS Retrofit and Complete Sloan SOLIS® Valves

1	EBV-304-A*	Cover/Sensor/Assembly - Closet SOLIS Electronic Single
	EBV-320-A	Cover/Sensor/Assembly (†Zurn®) - Closet SOLIS Single
	EBV-306-A*	Cover/Sensor/Assembly - Urinal SOLIS Single
	EBV-321-A	Cover/Sensor/Assembly (†Zurn®) - Urinal SOLIS Single
	EBV-379-A*	Cover/Sensor/Assembly - Closet SOLIS 1.1 gpf Single
	WES-24-A*	Cover/Sensor/Assembly - Closet SOLIS Dual
	EBV-328-A*	Cover/Sensor/Assembly - Urinal 0.25 gpf SOLIS Single
	EBV-385-A*	Cover/Sensor/Assembly - Urinal 0.125 gpf SOLIS Single
2	EBV-309-A	Cover Assembly - SOLIS Electronic Single Button Flush
	EBV-311-A	Cover Assembly - SOLIS Electronic Dual Flush
3	EBV-14	Locking Ring
	EBV-30	Locking Ring - for †Zurn® valves
4	EBV-312-A-C	Sensor Assembly SOLIS - Water Closet
	EBV-312-A-U	Sensor Assembly SOLIS - Urinal
	EBV-388-A	Module - SOLIS - 0.125 gpf Urinal
	EBV-382-A	Module - SOLIS - 1.1 gpf Single Button Flush
	WES-33-A	Module - SOLIS - Water Closet (Dual Flush)
5	EBV-134	Cover Rest Plate
6	EBV-145-A	Inside Cover Assembly (includes solenoid)
7	EBV-136-A	Solenoid
8	† †	Flex Tube Diaphragm Assembly
9	† †	Flush Volume Regulator
10	EBV-1017-A	Handle Cap
11	EBV-91	Range Adjustment Tool
12	EBV-22	Strap Wrench
13	EBV-137	7/64" Hex Wrench

† † Flow volume varies with valve model and desired flush volume. Consult the Repair Parts & Maintenance Guide for replacement part numbers.

* -BT Sloan Connected Product Models available.

For -SMT (SC Argus models) consult local Rep or contact Sloan Technical Support. For Troubleshooting and Replacement of SOLIS -SMT units, please consult the SOLIS Repair Parts & Maintenance Guide.

ITEM #	PART #	DESCRIPTION
--------	--------	-------------

Items Included with Complete Sloan SOLIS® Valves Only

14	H-633-AA	1" (25 mm) Sweat Solder Kit
	H-636-AA	¾" (19 mm) Sweat Solder Kit
15	H-700-A	1" (25 mm) Bak-Chek® Control Stop
	H-700-A	¾" (19 mm) Bak-Chek® Control Stop
16	H-1010-A	Vandal Resistant Stop Cap
17	EBV-36-A	Valve Body
17A	H-1015-A	Flow Control (Not Shown) (Urinal 0.5, 0.25, 0.125 gpf)
18A	V-600-AA	1½" (38 mm) x 10½" (229 mm) Vacuum Breaker (Model 8110/8111)
	V-600-AA	1½" (38 mm) x 15" (381 mm) Vacuum Breaker (Model 8113)
	V-600-AA	1½" (38 mm) x 23" (584 mm) Vacuum Breaker (Model 8115)
	V-600-AA	1½" (38 mm) x 26" (660 mm) Vacuum Breaker (Model 8116)
18B	V-600-A	3" (76 mm) Vacuum Breaker Assembly
18C	V-600-AA	1¼" (32 mm) x 10½" (229 mm) Vacuum Breaker (Model 8180)
18D	V-600-AA	¾" (19 mm) x 10½" (229 mm) Vacuum Breaker (Model 8186)
19	F-109	1½" (38 mm) Elbow Flush Connection
20A	F-5-AT	1½" Spud Coupling Assembly (Water Closet Models)
20B	F-5-AU	1¼" Spud Coupling Assembly (Model 8180)
20C	F-5-AW	¾" Spud Coupling Assembly (Model 8186)

† The brands and/or products names referenced herein may be subject to trademark rights of their respective owners. Use of the brands and names is for identification purposes only and does not imply affiliation with or endorsement by Sloan.

Manufactured in the U.S.A. by Sloan Valve Company under one or more of the following patents: U.S. Patents: D598,975; D599,436; 7,124,997. Other Patents Pending. BAK-CHEK®, PARA-FLO®, PERMEX®, TURBO-FLO®.

The information contained in this document is subject to change without notice.

SLOAN • 10500 SEYMOUR AVENUE • FRANKLIN PARK, IL 60131

Phone: 1-800-982-5839 or 1-847-671-4300 • Fax: 1-800-447-8329 or 1-847-671-4380 • sloan.com