





## ASSEMBLY INSTRUCTION FOR 26100 COFFEE TABLE

### HARDWARE LIST

NO.	ITEM	DESCRIPTIN	QTY.
1		JCB Bolt M6X16 MM	20
2		Allen wrench 4 MM	1
3		Flat washer M8X22 MM	10
4		JCB Bolt M8X20 MM	10
5		Allen wrench 5 MM	1

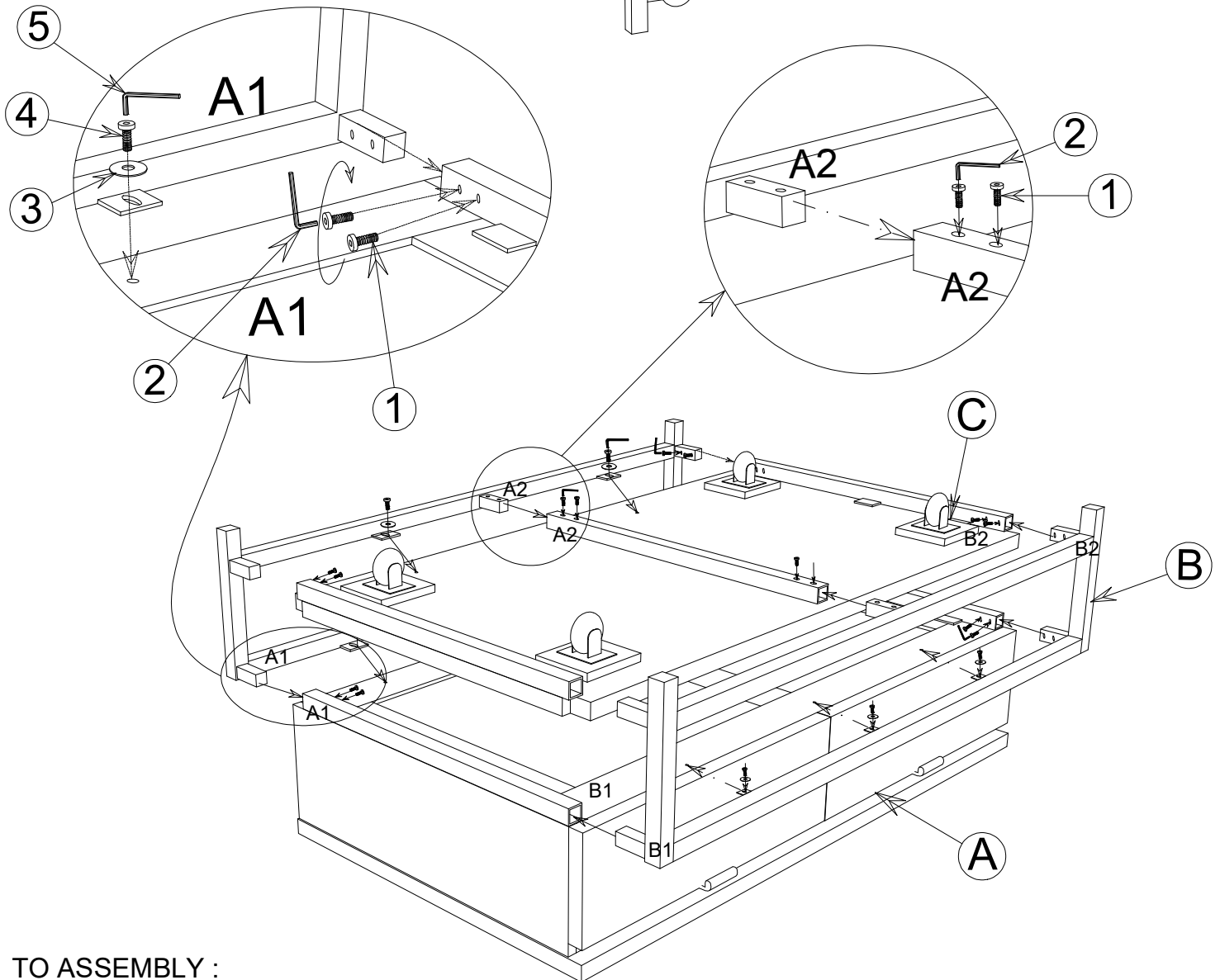
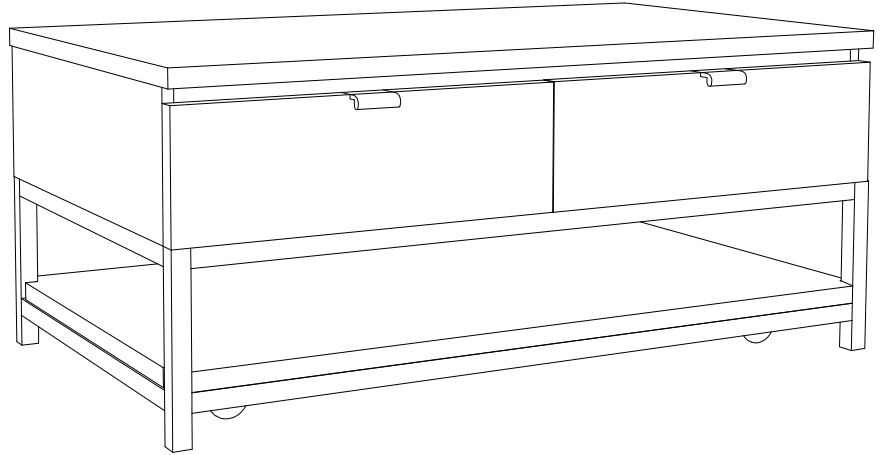

### TO ASSEMBLY :

- STEP 1 : Unpack coffee table and turn the top assembly (A) upside down. on a clean, soft surface.
- STEP 2 : Match the iron legs(B). use matching marks A1,A2 & B1,B2 - on top (A) & shelf (C).
- STEP 3 : Align holes in legs (B) with holes on bottom of the coffee table (A)& shelf (C) and slide it into position.
- STEP 4 : Thread the flat washer(3) ,JCB bolt (1&4) to leg (B&C) . Do not tighten bolts fully until all bolts are started.
- STEP 5 : Tighten bolts in step 4 fully with allen wrench (2&5) then carefully turn the coffee table upright.