

# **User's Manual**

## **8-Port Desktop Dual Speed Hub**

### **Contents**

Chapter 1 Introduction .....	1
Chapter 2 Features & Specifications .....	3
Chapter 3 Package Contents .....	4
Chapter 4 Physical Description .....	5
Chapter 5 Installation .....	8
Chapter 6 Trouble-shooting .....	10

## FCC COMPLIANCE STATEMENT

This equipment generates and uses radio frequency energy and if not installed and used properly, that is, in strict accordance with the instructions provided with the equipment, may cause interference to radio and TV reception. The equipment has been tested and found to comply with the limits for a Class A computing device in accordance with the specifications in Subpart B of Part 15 of FCC rules, which are designed to provide reasonable protection against such interference in a commercial environment. However, there is no guarantee that interference will not occur in a particular installation.

If you suspect this equipment is causing interference, turn your hub on and off while your radio or TV is showing interference to determine the source of the interference.

You can try to correct the interference by one or more of the following measures:

1. Reorient the receiving radio or TV antenna where this may be done safely.
2. To the extent possible, relocate the radio, TV or the other receiver away from the equipment.
3. Plug the computer which has the equipment installed into a different power outlet so that equipment and the receiver are on different branch circuits.

If necessary, you should consult the place of purchase or an experienced radio/television technician for additional suggestion.

**CAUTION** : The phone jack cannot be connected to telephone system.

# 1 Introduction

Congratulations on your purchase of our 8-port dual-speed hubs. Migrating from traditional 10Mbps Ethernet to 100Mbps Fast Ethernet is now simple and affordable with our dual-speed hubs. Our high performance 8-port desktop 10/100Mbps dual-speed hubs are equipped with 8 RJ45 dual-speed ports and one uplink switch.

Typically a dual-speed hub has two independent internal network segments: 10Mbps segment and 100Mbps segment. Depending on the speed of attached network devices, each individual port of a dual-speed hub provides Auto-Negotiation capability which automatically senses and selects optimum speed at 10Mbps or 100Mbps. A 10Mbps network device attached to the dual-speed hub will be able to communicate with other network devices attached to the hub running at 10Mbps. On the other hand, a 100Mbps network device attached to the dual-speed hub will be able to communicate with other devices attached to the hub running at 100Mbps. Therefore, dual-speed hub can be 10Base-T hub when all the connecting nodes are running at 10Mbps as illustrated in Figure 1-1, or can be 100Base-TX hub when all the connecting nodes are running at 100Mbps as illustrated in Figure 1-2. Our dual-speed hubs are the ideal hubs for both 10Base-T and 100Base-TX networks.

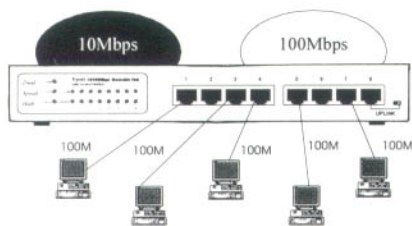

Figure 1-1 10Mbps segment connecting 10Mbps devices

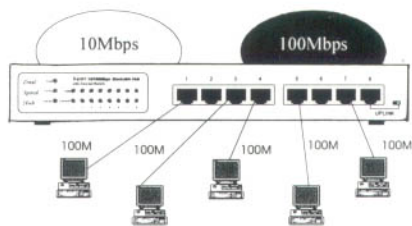

Figure 1-2 100Mbps segment connecting 100Mbps devices

\* CAUTION: If you connect both 10Mbps network devices and 100Mbps network devices to the dual-speed hub, the 10Mbps devices will not communicate with 100Mbps devices.

Dual-Speed hub with internal switching function automatically switches data traffic between devices running at different speed, which allows communications between ports running at 10Mbps and ports running at 100Mbps. Dual-Speed hub with internal switching function can save money by eliminate the need to purchase expensive Switches for users with mixed speed network environment. The connection of the dual-speed hub with internal switching function is illustrated as below :

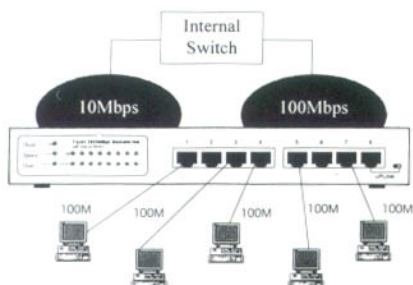

Figure 1-3 Internal switch links 10Mbps and 100Mbps segments

These dual-speed hubs' compact and slim design allows direct placing on the desktop or a small closet. They can also be conveniently mounted on the wall or the side of a desk to accommodate cabling consideration.

## **2** Features & Specifications

### **(1) Features**

- Consists of one internal 10Mbps Ethernet segment and one internal 100Mbps Fast Ethernet segment.
- Supports eight (8) Auto-Sensing RJ45 ports which automatically sense and select optimum speed and route data traffic to corresponding internal segments.
- Built-in Uplink selection for the last port (8th) to connect with regular straight-through cable to another hub.
- Built-in internal switching function (only for the model that has internal switch) automatically switches data traffic between devices running at different speed establishes communications between ports running at 10Mbps and 100Mbps.
- Support stackable function (only for the model that has stacking ports) can stack up to 4 hubs to form a logically single dual-speed hub.
- Desktop size and wall mountable
- Two Year warranty

### **(2) Specifications**

- Standards : IEEE 802.3 & 802.3u
- 10/100Mbps Ports : RJ45 x 8
- Hub LEDs : Power, Collision
- Port LEDs : 100Mbps, Link/Activity
- Dimensions : 8.7 x 4.6 x 1.18 in. / 220 x 117 x 30 mm
- Weight : 1.76 lb./800g (Non-stackable without internal switch)  
1.81 lb./820g (Non-stackable with internal switch)  
1.78 lb./810g (Stackable without internal switch)  
1.83 lb./830g (Stackable with internal switch)
- Power : 5V DC, 3A
- Operating Temperature : 32-131°F (0-55°C)
- Operating Humidity : 10-95% (Noncondensing)
- Emission : FCC Class A & CE

### 3 Package Contents

- One 8-port desktop Dual Speed Hub
- One external switching power adapter
- One power cable
- One set of (two pieces) stacking brackets and rubber stands
- Stacking Cable (only for the model that has stacking ports)
- User's manual

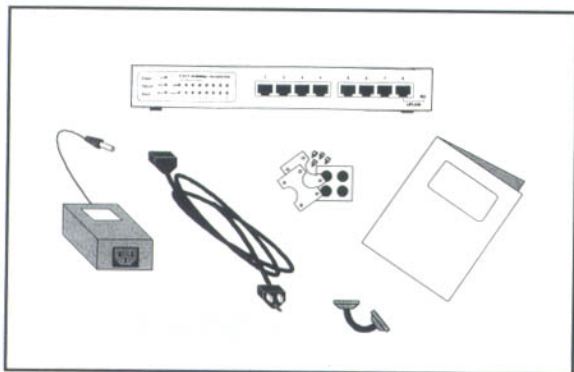
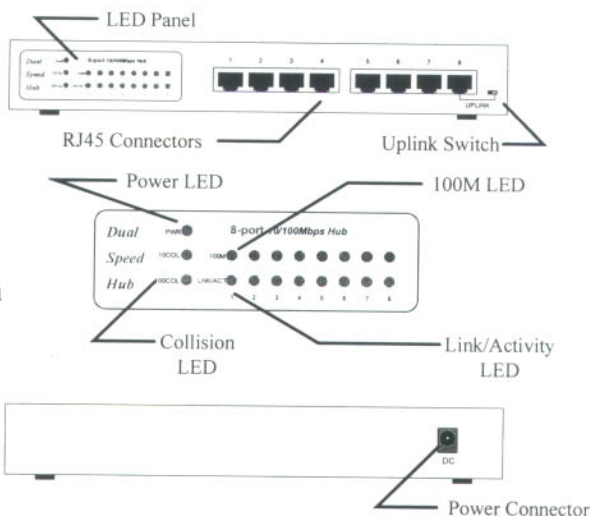

Figure 3-1 Package contents

## 4 Physical Description

### (1) Panel

8-port Non-stackable  
Dual-Speed Hub  
without Internal Switch



8 -port Non-stackable  
Dual-Speed Hub  
with Internal Switch

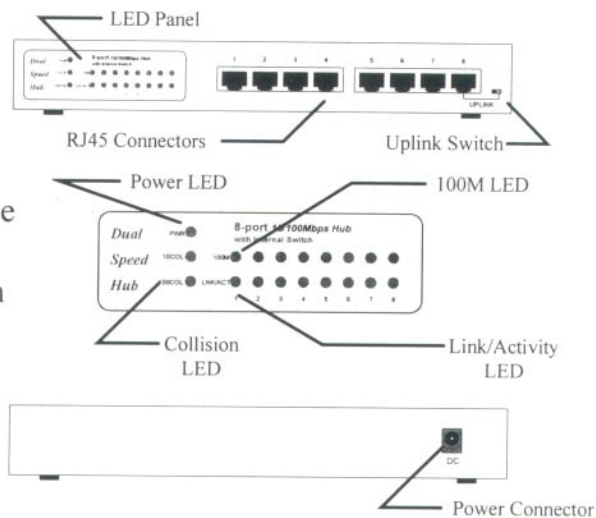
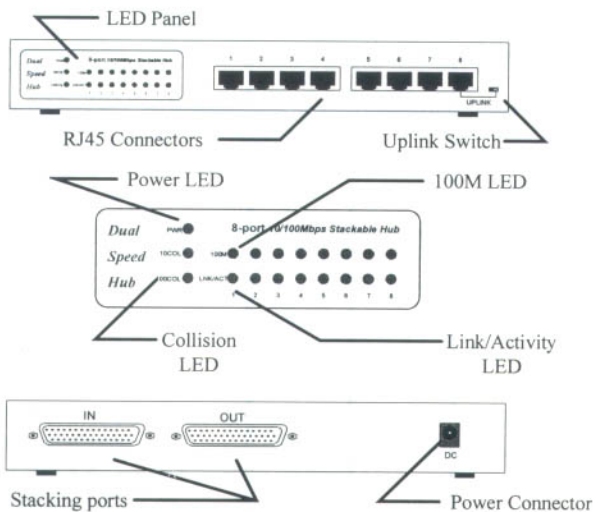

Figure 4-1 Panel description

8-port Stackable  
Dual-Speed Hub  
without Internal Switch



8 -port Stackable  
Dual-Speed Hub  
with Internal Switch

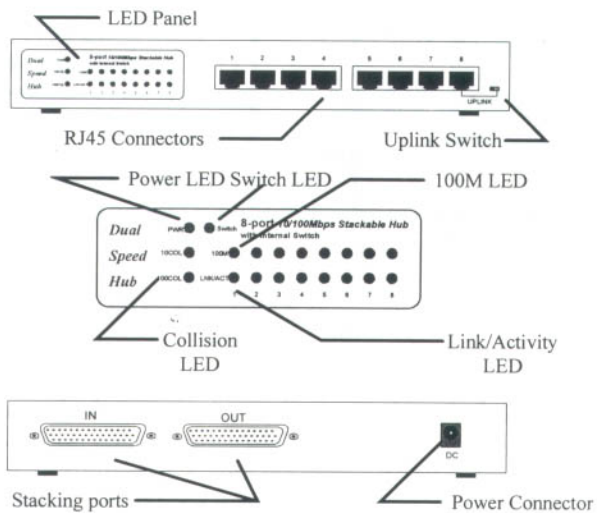

Figure 4-1 Panel description (cont.)

## (2) LED

LED	Color	Status	Description	Number of LED
PWR (Power)	Green	Lit	Power is supplied	One for the whole Hub
		Off	No power	
COL (Segment Collision)	Yellow	Lit	Collision detected in this segment	One for 10Mbps segment and one for 100Mbps segment
		Off	No Collision	
LNK/ACT (Link/Activity)	Green	Lit	A valid link is established	One for each port
		Flash	Data packets received	
		Off	No link is established	
100M (100Mbps)	Green	Lit	This port run at 100Mbps	One for each port
		Off	Not connected or run at 10M	
Switch	Green	Lit	Internal Switch is active	One for the whole hub (only for the model that has stacking ports and internal switch)
		Off	Internal Switch is inactive	

Table 4-1 LED description

## 5 Installation

### 1. Operating Environment

These dual-speed hubs must be installed and operated within the limits of specified operating temperature and humidity (see previous section under Specifications). Do not place objects on top of the unit. Do not obstruct any vents at the sides of the unit. Do not position the hub near any heating source such as heater, radiator, or direct exposure to sun. Prevent entering of water and moisture into the unit. If necessary, use dehumidifier to reduce humidity.

### 2. Connecting to network devices

Connect one end of the network cable to any of the eight RJ45 ports on the front panel, and connect the other end of the network cable to the RJ45 port of the network device. The network cables must comply with EIA/TIA 568 specifications and Category 5 standard for 100Mbps data rate or Category 3 or higher for 10Mbps data rate. Maximum length between the hub and any network devices is 100 meters (300ft). Once the network cable is connected on both ends and the attached network devices are powered on, the green Link Status LED should be lit. If the connected network devices are running at 100Mbps, the green Speed LED (100M) should also be lit.

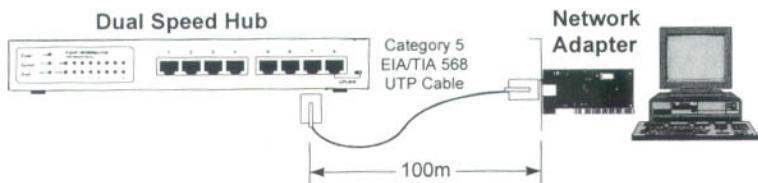

Figure 5-1 Connect the hub and network device

### 3. Uplink to Another Hub

Use the Uplink port (8th port) to connect to another hub as illustrated below. Connecting cable must comply with EIA/TIA 568 specifications and Category 5 (100Mbps) standards to connect the hubs. The Uplink port of the Dual-Speed hub supports Auto-Sensing function which will automatically sense the speed of the connected hub and operates at either 100Mbps or 10Mbps speed. If the connected hub is another Dual-Speed hub or 100Base-TX hub, the transmission speed between the two hubs will be set at 100Mbps and the green Speed (100M) LED should be lit. The maximum length of the cable should not exceed 5 meters (15ft) when connecting two hubs running at 100Mbps and 100 meters (300ft) when connecting two hubs running at 10Mbps.

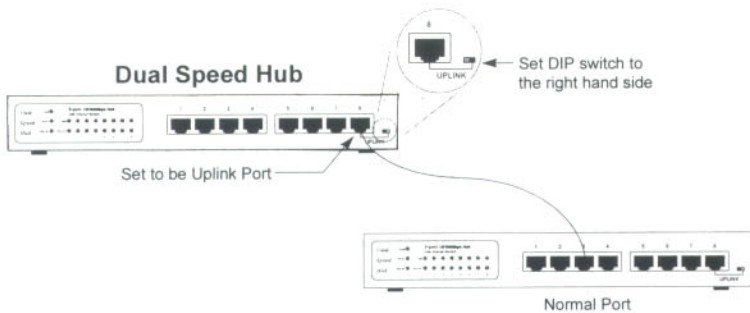

Figure 5-2 Uplink to another hub

#### 4. Stacking Hubs Together (only for the hubs with stacking ports)

The models that provide two stacking ports can stack together. Users may connect two hubs using the supplied stacking cable. Connect one end of the stacking cable to the “IN” stacking connector of the hub and the other end of the stacking cable to another hub “OUT” stacking connector. You may stack up to 4 hubs. The hubs cascaded together through stacking ports are in one collision domain and therefore considered as one logical hub. Only one Dual Speed Hub with internal switch is required to provide internal switching function to all the ports in the stacked hubs.

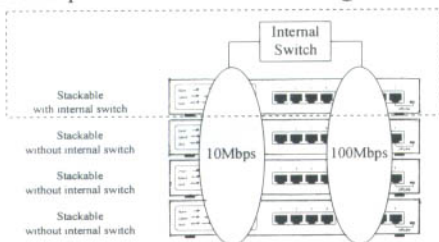

Figure 5-3 Stack 4 hubs together

\* Caution : When you have two or more hubs with internal switch stacked together, only one hub’s internal switch is active, the others are inactive. Such design will eliminate a “Loop” in the network that might cause the whole network to malfunction.

#### 5. Connecting the power

Connect the power cord to the power outlet and the AC power adapter. Connect the output end of AC power adapter to the power connector on the rear panel of the unit. The green Power LED on the front panel should be lit.

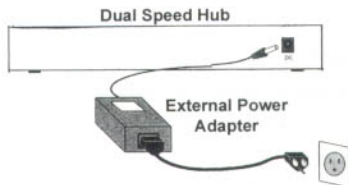

Figure 5-4 Connect the AC power adapter

## **6** Trouble-shooting

### **1. Power LED is not lit**

- Check if the power cord is properly connected to the external switching power adapter and the power outlet. Make sure the DC power jack is firmly plugged into the power socket of the hub.

### **2. Link Status LED is not lit**

- Check the power switch of the network devices attached to the hub; make sure they are turned ON.
- Check the network cables; make sure they are properly connected to the hub and the network devices.
- Check the network cables; make sure the cables comply with EIA/TIA 568 specification. Use straight-through Category 5 cables for 100Mbps connection and Category 3 or higher cables for 10Mbps connection.
- Check the slide switch and make sure it's in normal position when you use the last port on the hub to connect to workstations or file servers.

### **3. 8th port's Link Status LED is not lit when it is uplinked to another hub**

- Make sure the uplink slide switch is shifted to "uplink" position.
- Check the network cable; make sure it is properly connected to both hubs. The slide switch next to the last port should be shifted to "uplink" position. One end of the cable should be connected to last port while the other end of the cable should be connected to a regular port. Do not connect the cable to both uplink ports.
- Check the network cable; make sure the cable complies with EIA/TIA 568 specification. Use CAT5 cables for 100Mbps connection and minimum CAT3 cables for 10Mbps connection.
- Check the network cable; make sure the maximum length does not exceed 5 meters (15ft) when this port is used for 100Mbps connection.

### **4. Collision LED flashes constantly**

- Remove all the network cables; connect the cables back one by one to isolate the source of the collision.
- Check the network cable, inferior cable quality will result in excessive collision and error packets.

**[!] Contact your dealer if problem persist.**