

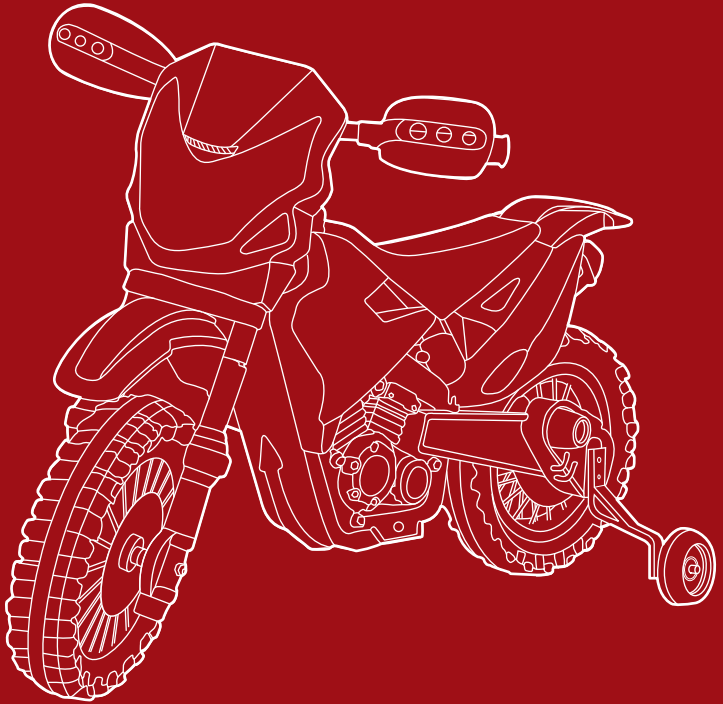

BEST CHOICE
PRODUCTS



INSTRUCTION MANUAL

Kids Ride-On Dirt Bike
with Training Wheels

Ver. 7

SKY3486 + SKY3487 + SKY5110 + SKY6977 + SKY6978 + SKY6979

⚠ WARNING

To reduce the risk of injury, adult supervision is required. Never use on roadways, near motor vehicles, on or near steep inclines or steps, swimming pools or other bodies of water; always wear shoes, and never allow more than one rider.

FOR: 3-6 YEARS OLD & UP TO 44 LBS

⚠ WARNING

CHOKING HAZARD - Small parts.
Not for children under 3 years old.

⚠ WARNING

ADULT ASSEMBLY REQUIRED



Charge for **8-10 hrs**
before initial use.

After initial charge,
follow the normal
recommended
charging time.



NOTICE

Please retain these instructions for future reference.

This vehicle must be assembled by an adult who has read and understood the instructions in this manual. Keep the packaging and bags away from children and dispose of all packaging before use. Always use common sense and safe practices when operating this vehicle. This product contains or emits chemicals known in the state of California to cause cancer or birth defects or other reproductive harm.

The following safety hazards may result in serious injury or death:

- This product contains small parts. Keep children away during assembly. Make sure to remove all packaging material and parts from underneath the vehicle body.
- Never open the battery. Batteries contain lead and lead compounds (acids) that are toxic and corrosive, and known to the state of California to cause cancer and reproductive harm.
- Limbs, hair, and clothing can get caught in moving parts. Always wear shoes, keep limbs away from moving parts, and do not wear loose clothing while operating this vehicle.
- This vehicle does not have brakes or braking capability. Do not leave a child unattended during operation. Do not use this in a location that may require braking capability, as this could result in loss of control, which may cause serious injury or death.
- Use of this vehicle near streets, motor vehicles, steps, bodies of water, sloped surfaces, hills, wet areas, flammable vapors, in alleys, at night, or in the dark could result in an unexpected accident.
- Use of this vehicle in unsafe conditions such as snow, rain, loose dirt, mud, sand, or gravel may result in an unexpected accident such as tipping over, and could damage the electrical system or battery.
- Do not operate this vehicle in an unsafe manner. Examples include but are not limited to:
 - Pulling the vehicle with another vehicle or similar device
 - Allowing more than one rider
 - Pushing the user
 - Traveling at an unsafe speed
- This product is intended for residential use only.

WARNING

The following safety hazards may result in serious injury or death:

- **RISK OF FIRE:** Do not bypass fuse. This may overload and damage the electrical system. Replace only with original size and type.
- Do not mix old and new batteries;
- Do not mix alkaline, stand (carbon-zinc) or rechargeable batteries.
- Use of a battery or charger other than the supplied rechargeable battery and charger may cause a fire or explosion. Only use the supplied battery and charger.
- Use of the rechargeable battery and charger for any other product may result in overheating, fire, or explosion. Never use the supplied rechargeable battery and charger with another product.
- Explosive gases are created during charging. Charge the battery in a well-ventilated area. Do not charge the battery near heat or flammable materials.
- Contact between the positive and negative terminals may result in fire or explosion. Avoid direct contact between the terminals. Picking up the battery by the wires or charger can cause damage to the battery and may result in a fire. Always pick up the battery by its case or handles.
- Liquids on the battery may cause fire or electric shock. Always keep all liquids away from the battery and keep the battery dry. Contact or exposure to battery leakage (lead acid) may cause serious injury. If contact or exposure occurs immediately call your physician. If the chemical is on the skin or in the eyes, flush with cool water for 15 minutes. If the chemical was swallowed, immediately give the person water or milk. Do not give water or milk if the patient is vomiting or has a decreased level of alertness. Do not induce vomiting.
- Battery posts, terminals, and related accessories contain lead and lead compounds (acid) - chemicals known to the State of California to cause cancer, reproductive harm, and are toxic and corrosive. Never open the battery.
- Tampering or modifying the electric circuit system may cause a shock, fire or explosion and permanently damage the system. Exposed wiring and circuitry in the charger may cause electric shock. Always keep the charger housing closed.

WARNING

To reduce the risk of injury, adult supervision is required. Never use on roadways, near motor vehicles, on or near steep inclines or steps, swimming pools or other bodies of water; always wear shoes, and never allow more than one rider.

The following safety hazards may result in serious injury or death:

- Never leave a child unattended.
- Always sit in the seat when using this vehicle.
- Keep your hands, hair, and clothes away from moving parts.
- Always wear shoes when operating this vehicle.
- Only one rider is allowed on the vehicle at a time.
- Children under 3 years of age cannot use the vehicle.
- Only drive on level ground.
- Do not go near swimming pools or other bodies of water, drop-offs, or up and down steep inclines.
- Do not drive the vehicle into loose dirt, mud, sand, fine gravel, or on wet surfaces.
- Do not drive the vehicle on streets or near cars.

SPECIFICATIONS

| | |
|----------------------------|---------------------------------|
| Overall Dimensions | 41"(L) x 20"(W) x 28"(H) |
| Weight | 20.3 lbs. |
| Weight Capacity | 44 lbs. |
| Age Range | 3 - 6 years old |
| Max Speed | 2.4 mph. |
| Initial Charge Time | 8 - 10 hours |
| Charging Time | 8 - 12 hours |
| Run Time | 30 - 40 minutes |
| Battery Type | 1 - Rechargeable SLA - 6V 4.5AH |
| Electric Motor | 20W |
| Charger | Output: DC 6V 500MA |
| Material | PP (Polypropylene) & Iron |

CARING FOR YOUR RIDE-ON

- Park the vehicle indoors or cover it with a tarp to protect it from wet weather.
- Do not leave the vehicle in the sun for long periods of time or fading may occur. Store in shade or cover with tarp.
- Do not wash the vehicle with a hose.
- Do not wash the vehicle with soap.



44 LBS
CAPACITY



1 PERSON
ASSEMBLY



UP TO 60 MIN.
ASSEMBLY

TOOLS REQUIRED



PHILLIPS
SCREWDRIVER



PLASTIC WRENCH
(2 PROVIDED)



SPANNER
(PROVIDED)



M5 SPANNER
(PROVIDED)



2 AA BATTERIES
(NOT INCLUDED)

HARDWARE

1

M4x13mm
SCREW



6 PCS

2

M5x30mm
BOLT



2 PCS

3

M5 NUT



2 PCS

4

M12x140mm
BOLT



1 PC

PARTS

A

HANDLEBARS

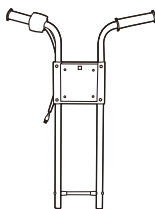

1 PC

B

SIDE MIRROR

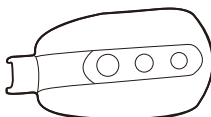

2 PCS

C

FENDER

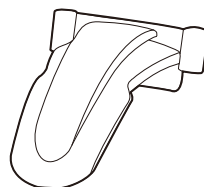

1 PC

PARTS

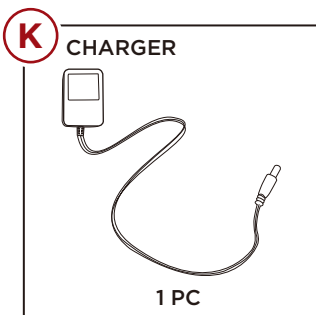
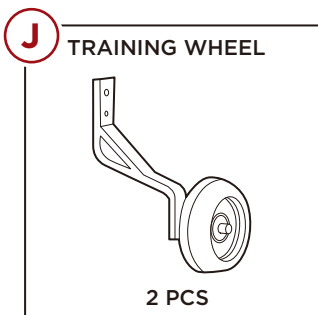
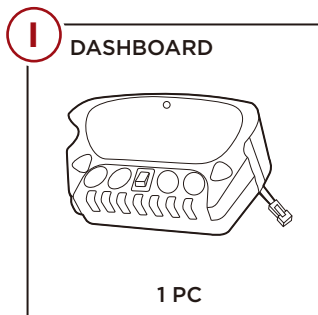
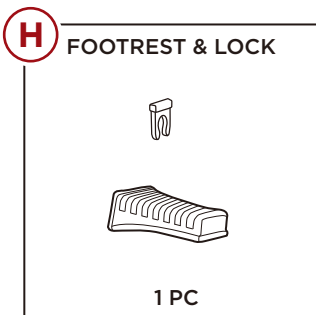
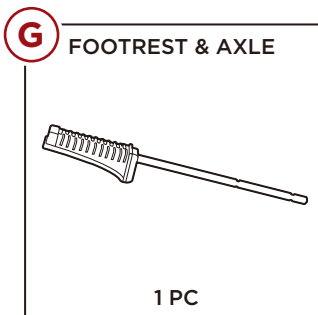
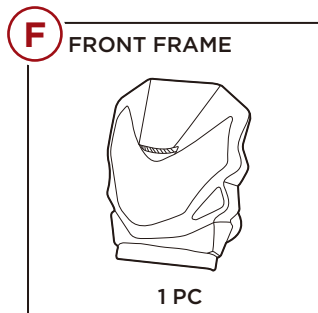
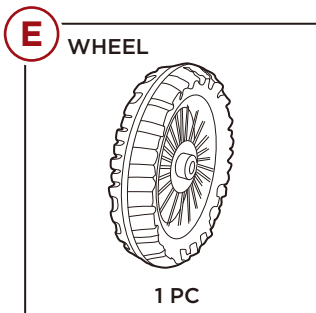
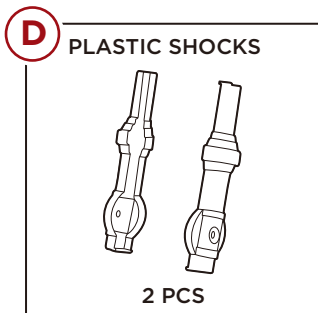

PRODUCT ASSEMBLY

1

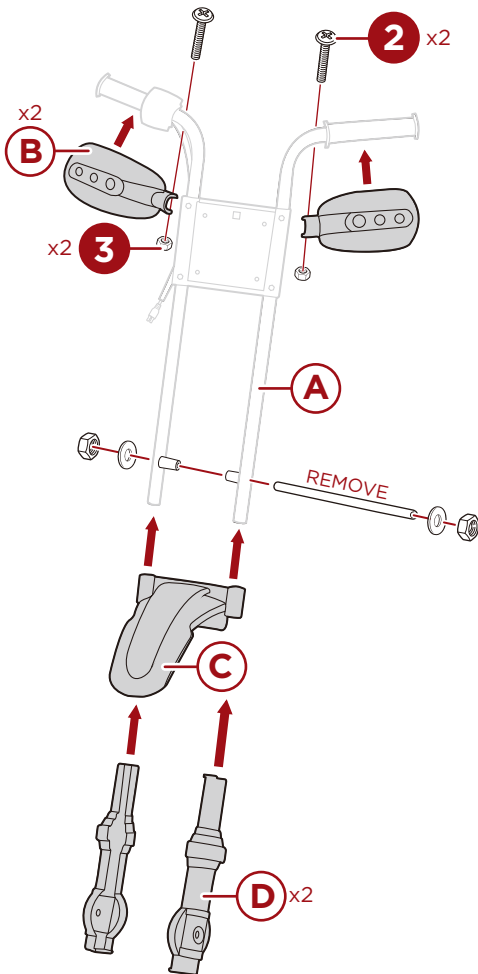

Remove the nuts, washers, spacers, and front axle from the part A handlebars.

Slide the part C fender and part D shocks onto the handlebar rails.

Attach two part B side mirrors with two part 2 bolts and two part 3 nuts, one bolt and nut per mirror.

2

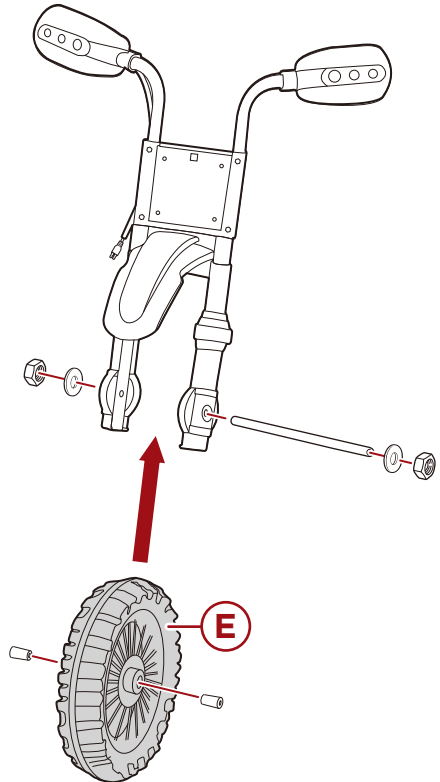

Insert the two spacers from the front axle into the part E wheel. Place the wheel between the handlebar rails.

Slide the front axle through the rails and wheel, and secure it with two washers and two nuts, one washer and nut per side.

PRODUCT ASSEMBLY

3

Attach the part F front frame to the part A handlebars with four part 1 screws.

NOTE: When attaching parts, make sure the wire connector on part F points up.

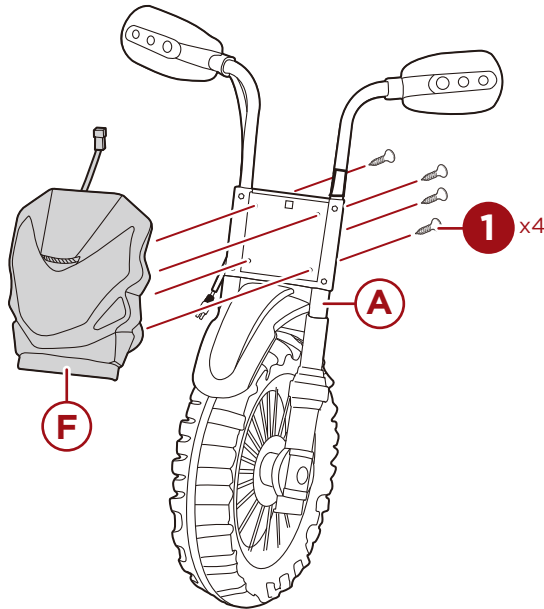

4

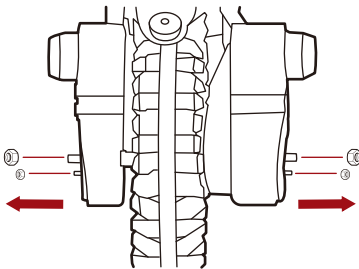

Remove the four nuts attached to the rear axle/gear box on the back of the motorcycle.

Attach the two part J training wheels by replacing the four nuts, two on each side.

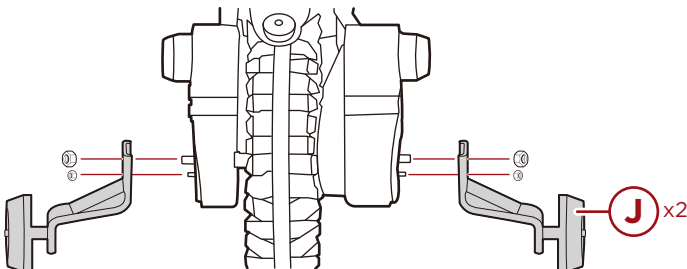

PRODUCT ASSEMBLY

5

Attach the front assembly to the motorcycle with the part 4 bolt.

Join the connector on the right side of the handlebars to the connector leading from the back of the motorcycle.

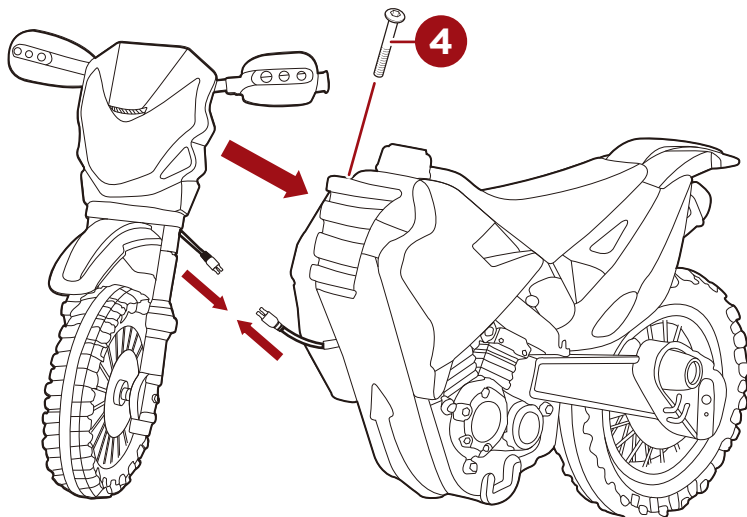

6

Slide the part G footrest and axle through the body of the motorcycle.

Insert the part H footrest onto the other side of the axle and secure it with the footrest lock.

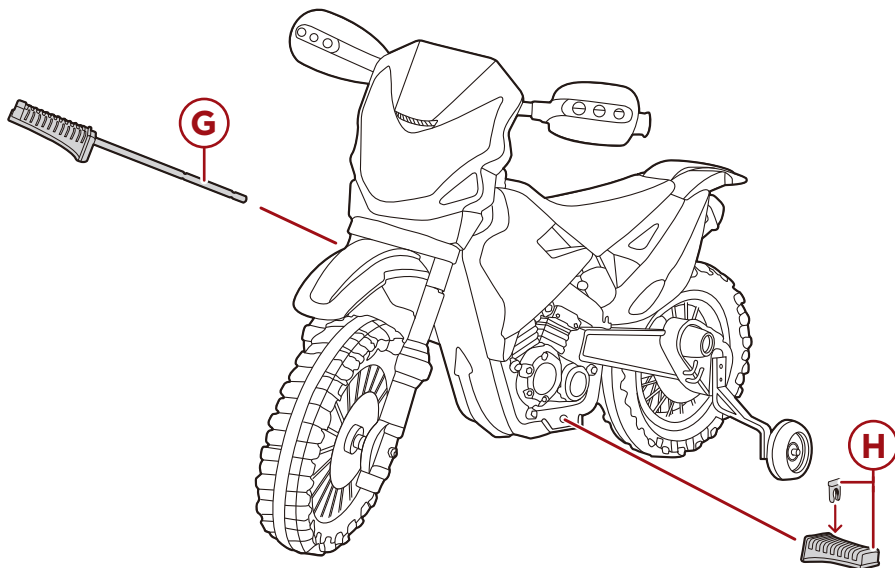

PRODUCT ASSEMBLY

7

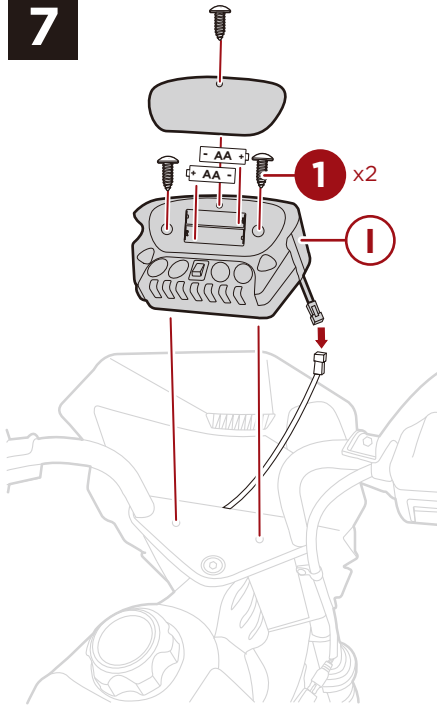

Use a screwdriver to open the compartment on the part 1 dashboard. Insert 2 AA batteries into the designated slots. Join the connector on the dashboard to the corresponding connector leading from the front frame.

Attach the dashboard to the motorcycle with two part 1 screws. Close the dashboard compartment and secure it with the provided screw.

DASHBOARD DIAGRAM

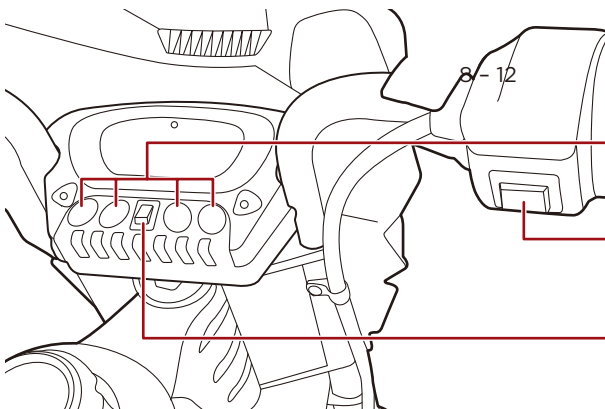

SOUND EFFECTS: Play horn, blinker, and engine ignition sounds

START: Drive forward. Release the start button to slow down and stop

LIGHT: Turn on lights

CHARGING INSTRUCTIONS AND WARNINGS

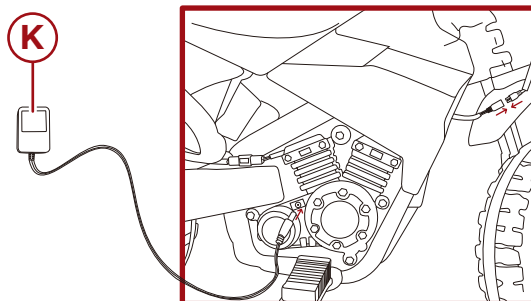

- Charging socket is located in the center of the motorcycle on the right side. Insert one end of the part K charger into the charging socket and plug the other end into a wall outlet.
- Charge the battery 8 - 10 hours before initial use.
- On average, you will need to charge the battery between 8 and 12 hours. Do not charge the battery for more than 15 hours. Failure to charge the battery as directed could cause permanent damage to the battery and void the warranty.
- Damage to the battery may occur if it is allowed to drain completely. Do not allow the battery to drain completely.
- Check the battery and charger (supply cord, connector) for wear and damage before charging. Do not charge the battery if damage has occurred.
- Only an adult who has read and understood the safety warnings should handle, charge and recharge the battery.

TROUBLESHOOTING

| PROBLEM | REASON | SOLUTION |
|---|---|---|
| Vehicle does not move | Low battery | Fully charge the battery |
| | Electrical protection | Stop use for several minutes and restart |
| | Switch not in the correct position | Completely press in switches |
| | Battery connectors disconnected | Plug in battery connectors |
| Battery does not recharge | Battery connectors disconnected | Plug in battery connectors |
| | Charger not connected to socket or outlet | Completely plug in the charger |
| Battery does not last | Battery does not have a full charge | Fully charge the battery |
| Battery is warm and makes a slight noise while charging | Normal | Normal |
| Slow speed | Low battery | Fully charge the battery |
| | Overloaded vehicle | Reduce the weight on the vehicle |
| | Uneven or sloped road | Drive on flat pavement |
| Vehicles shakes while driving | Loose connection to motor | Ensure the motor is properly connected to the battery |



HELP CENTER



Question about your product? We're here to help. Visit us at:

help.bestchoiceproducts.com



Chat Support



Product Inquiry



Orders FAQ



Product Assembly



Returns & Refunds

PRODUCT WARRANTY INFORMATION

All items can be returned for any reason within 60 days of the receipt and will receive a full refund as long as the item is returned in its original product packaging and all accessories from its original shipment are included. All returned items will receive a full refund back to the original payment method. All returned items will not be charged a re-stocking fee.

All returned items require an RA (Return Authorization) number, which can only be provided by a Best Choice Products Customer Service Representative when the return request is submitted. Items received without an RA may not be accepted or may increase your return processing time. Once an item has been received by Best Choice Products, refunds or replacements will be processed within 5 business days.

All returns must be shipped back to the Best Choice Products Return Center at the customer's expense. If the reason for return is a result of an error by Best Choice Products then Best Choice Products will provide a pre-paid shipping label via email. Boxes for return shipping will not be provided by Best Choice Products, and is the customer's responsibility to either use the original shipping boxes or purchase new boxes.

Pictures may be required for some returns to ensure an item is not damaged prior to its return. Items returned are not considered undamaged until they are received by Best Choice Products and verified as such. All damages to items are the customer's responsibility until the item has been received by and acknowledged by Best Choice Products as undamaged.

© 2023 Best Choice Products, Inc. All rights reserved. Distributed by Best Choice Products, Inc. Tustin, CA 92780

WARNING

Manufacturer and seller expressly disclaim any and all liability for personal injury, property damage or loss, whether direct, indirect, or incidental, resulting from the incorrect attachment, improper use, inadequate maintenance, unapproved modification, or neglect of this product.