

ASSEMBLY INSTRUCTION

END TABLE WITH CLEAR TEMPERED GLASS TOP

A Frame

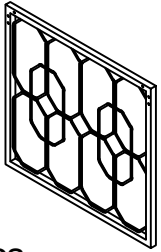

2pcs

B Cross Support

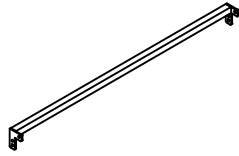

2pcs

C Table Top

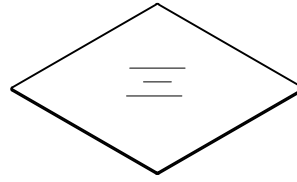

1pc

D Bolt
Ø1/4"X1/2"



12pcs

E Allen Key
M4



1pc

F Glass Pad
Ø12x2mm

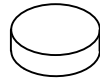

8pcs

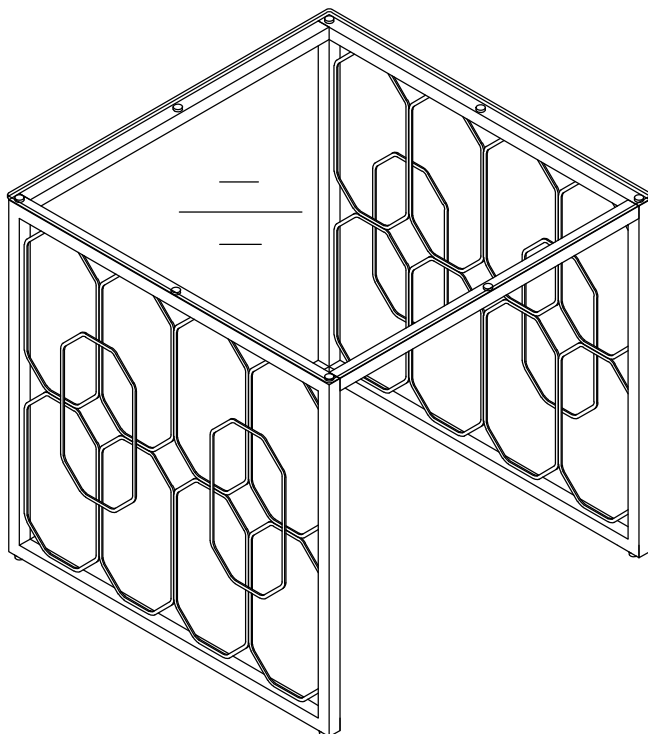

This page lists all the contents included in the box. Please take the time to identify the hardware as well as the individual components to this product. As you unpack and prepare for assembly, place the contents on a carpeted or padded area to protect them from damage.

1 Assemble Frame (A) with Cross Support (B) using Bolt (D) to fasten by Allen Key (E).

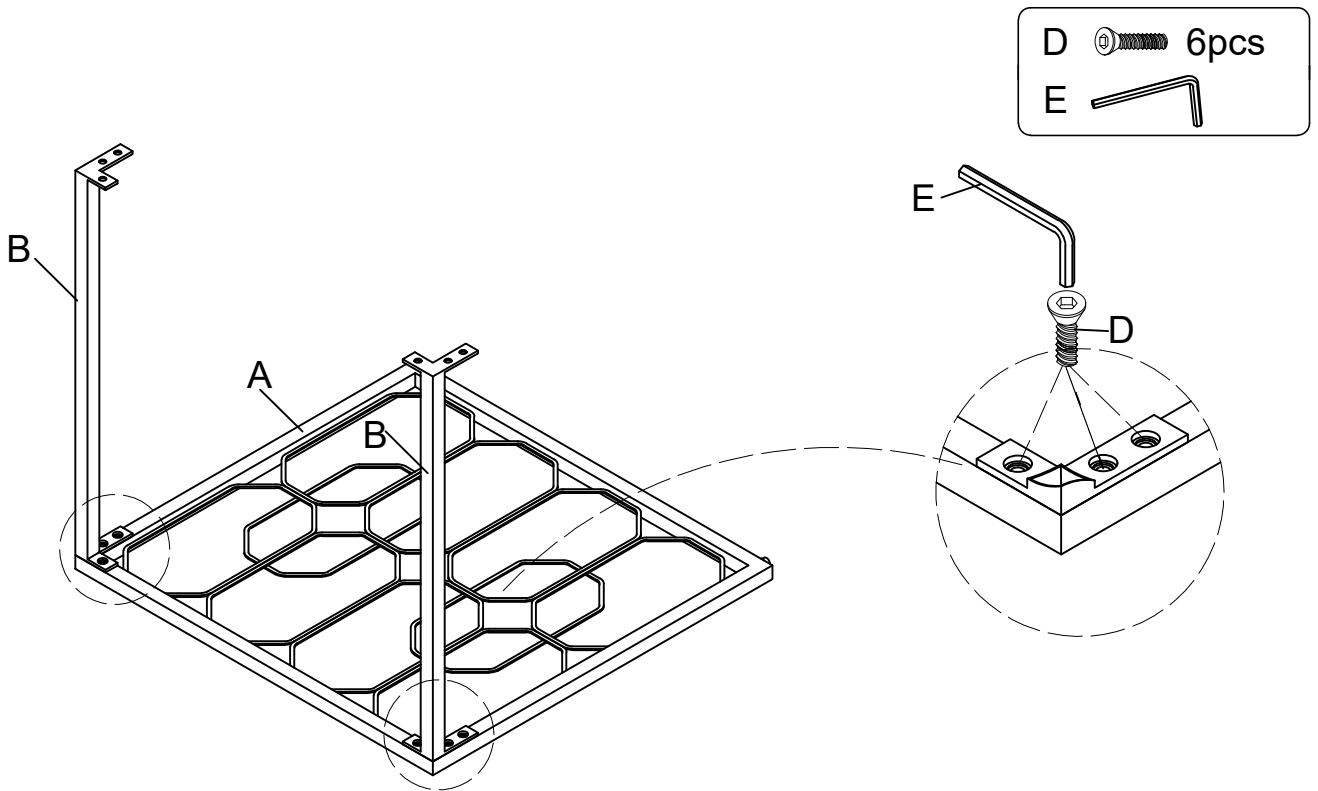

2 Assemble another piece of Frame (A) with Cross Support (B) using Bolt (D) to fasten by Allen Key (E).

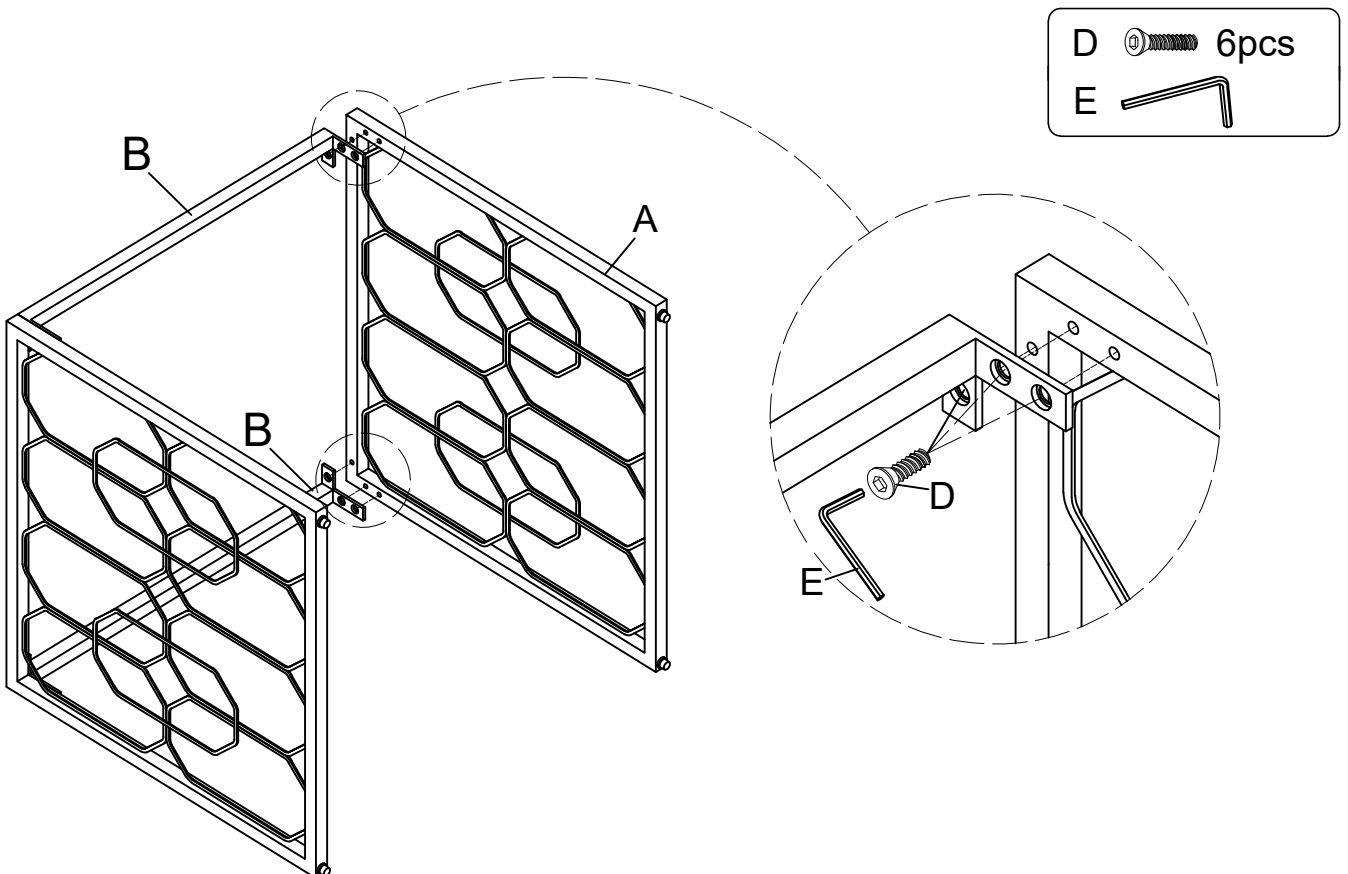

3 Assemble Glass Pad (F) to Frame (A) & Cross Support (B) as below shown.

F ○ 8pcs

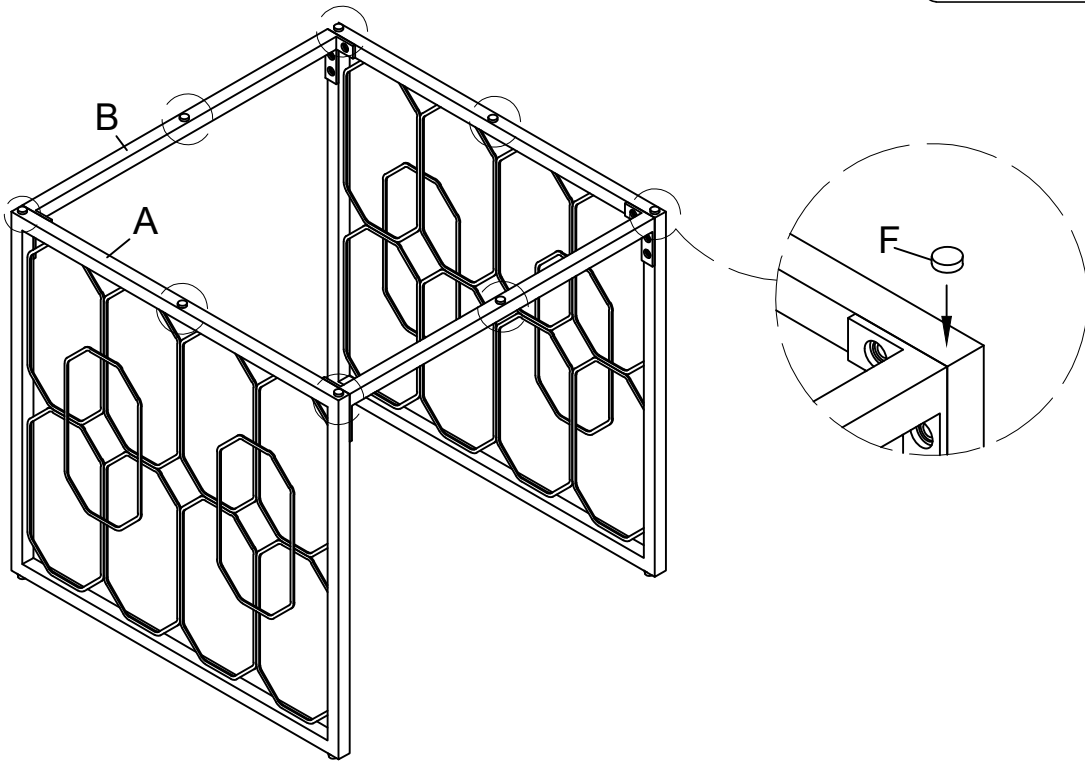

4 Put Table Top (C) to the Glass Pad (F) on Frame (A) and Cross Support (B) as below shown.

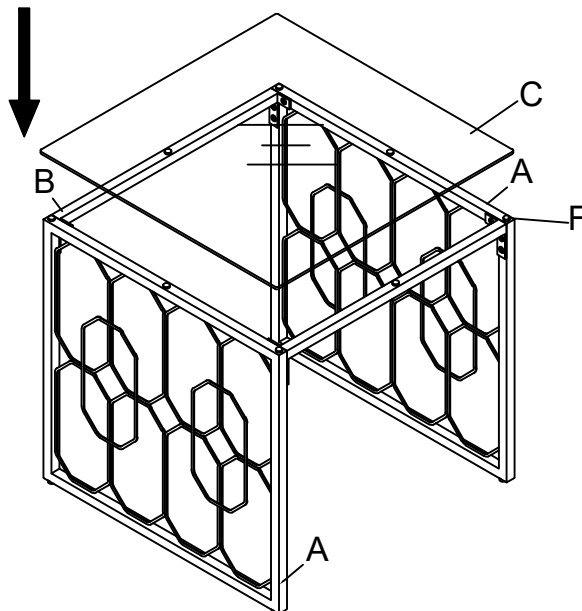

Adjust any parts out of alignment and tighten all bolts and screws from steps 1 through 4.

Cleaning & Care

Treat surface with care. Surface is resistant to scratches but is not scratch resistant. Clean surfaces with a dry or damp soft cloth. Do not use abrasive cleaners. Hardware may loosen over time. Periodically check that all connections are tight.

ASSEMBLY INSTRUCTION

COFFEE TABLE WITH CLEAR TEMPERED GLASS TOP

A Frame

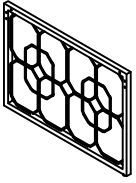

2pcs

B Cross Support

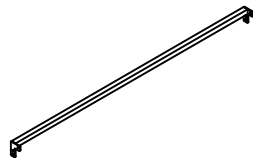

2pcs

C Table Top

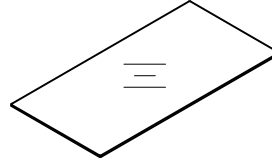

1pc

D Bolt
Ø1/4"X1/2"

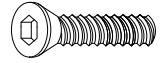

12pcs

E Allen Key
M4



1pc

F Glass Pad
Ø12x2mm

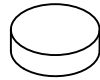

6pcs

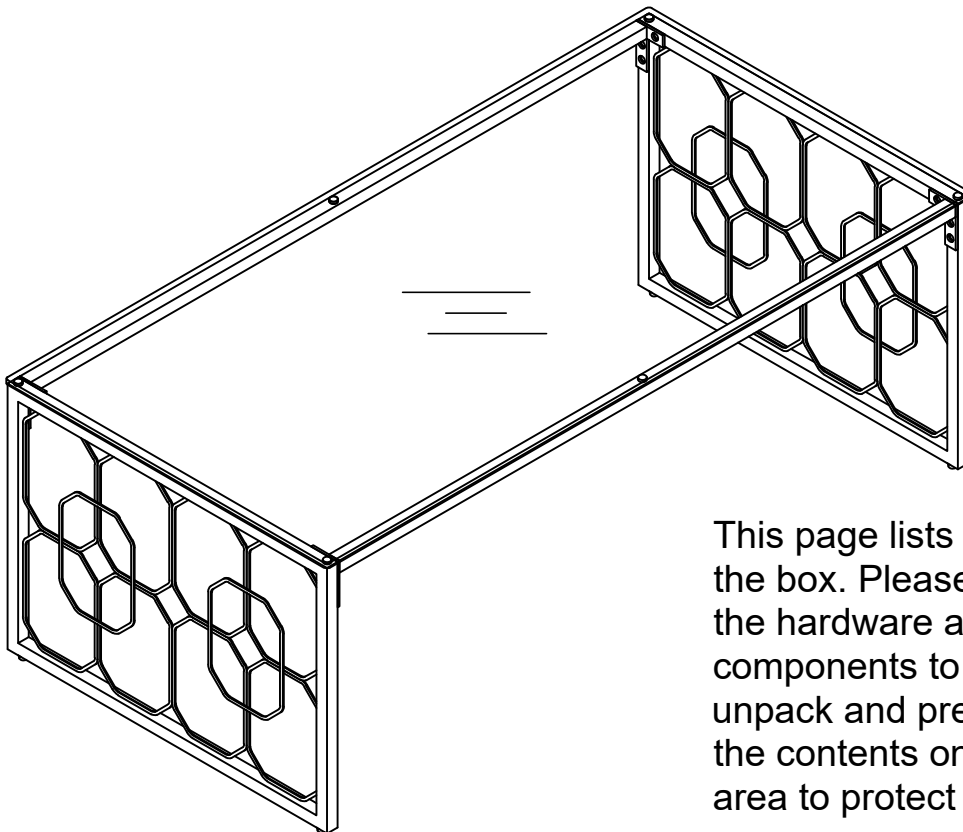

This page lists all the contents included in the box. Please take the time to identify the hardware as well as the individual components to this product. As you unpack and prepare for assembly, place the contents on a carpeted or padded area to protect them from damage.

1 Assemble Frame (A) with Cross Support (B) using Bolt (D) to fasten by Allen Key (E).

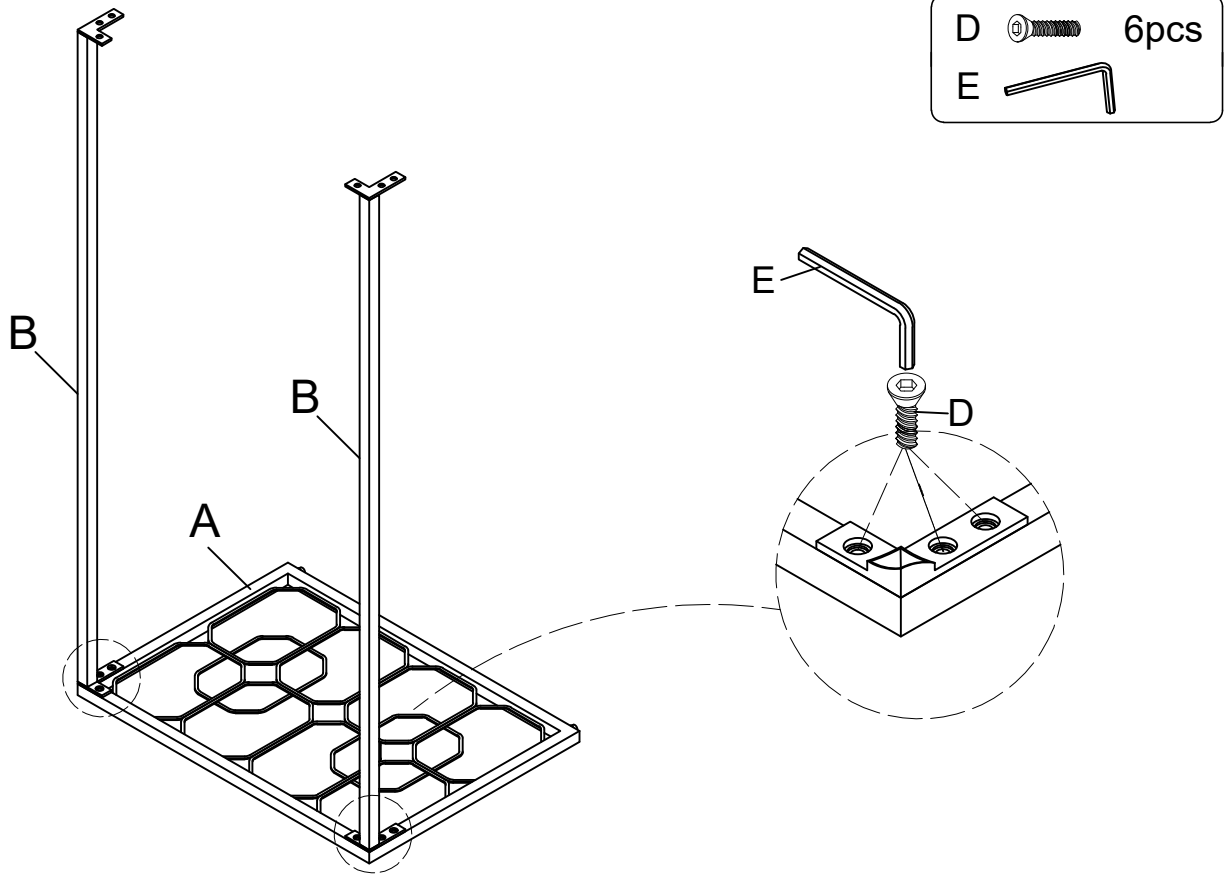

2 Assemble another piece of Frame (A) with Cross Support (B) using Bolt (D) to fasten by Allen Key (E).

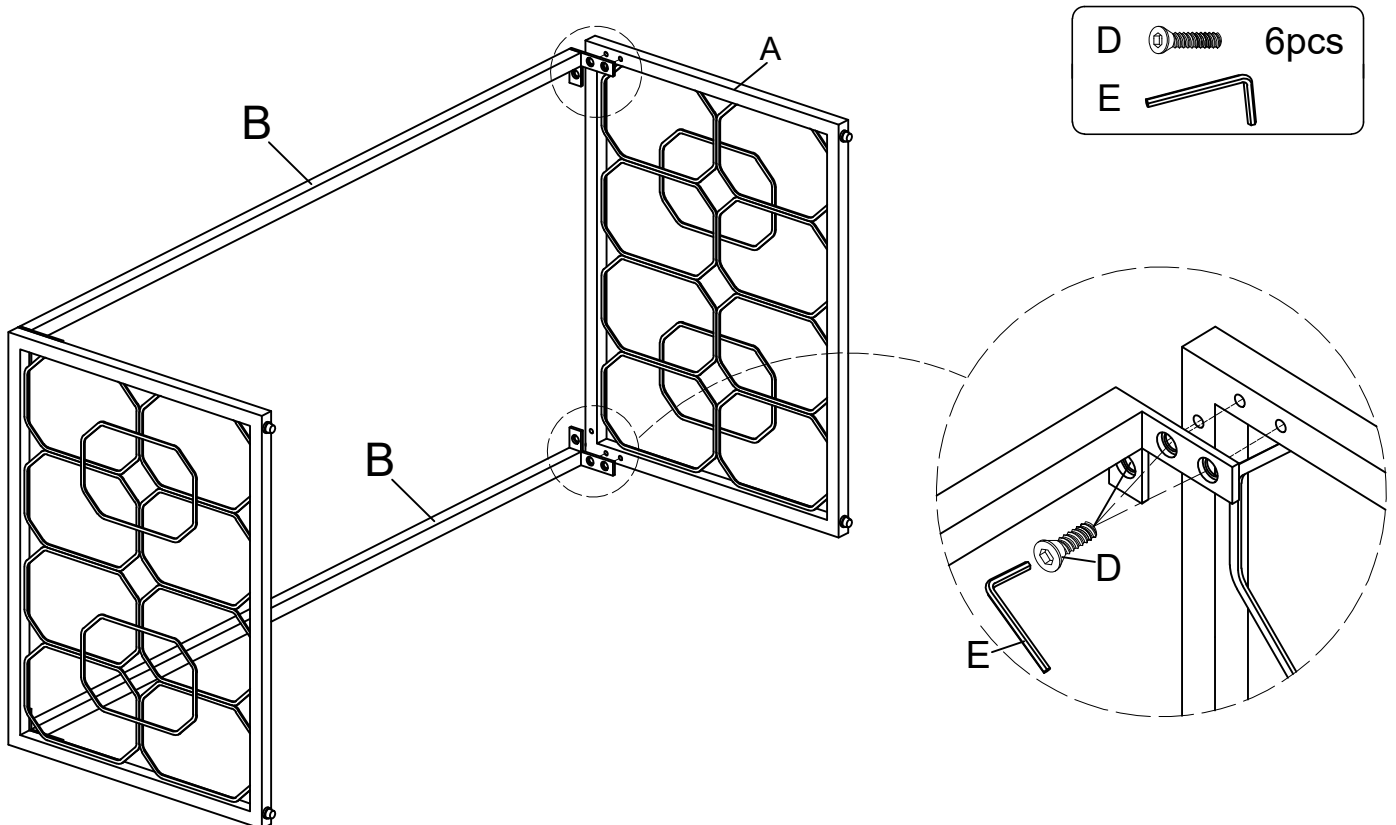

3 Assemble Glass Pad (F) to Frame (A) & Cross Support (B) as below shown.

F  6pcs

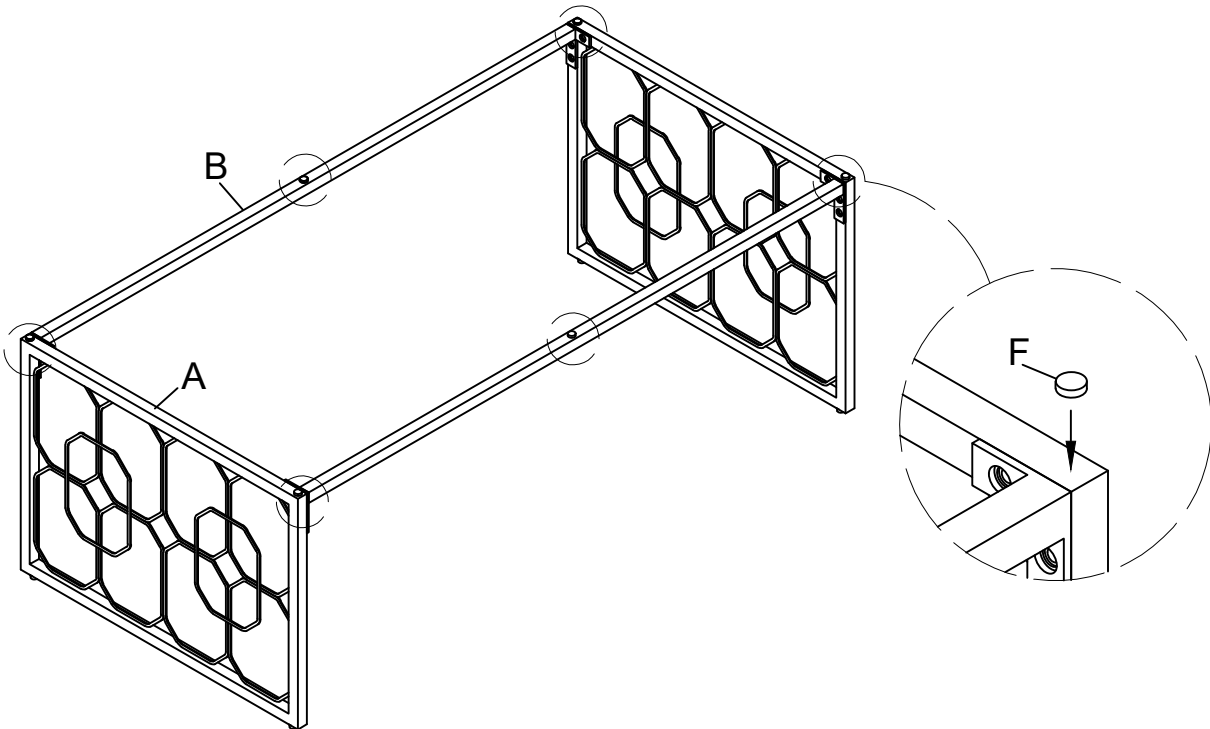

4 Put Table Top (C) to the Glass Pad (F) on Frame (A) and Cross Support (B) as below shown.

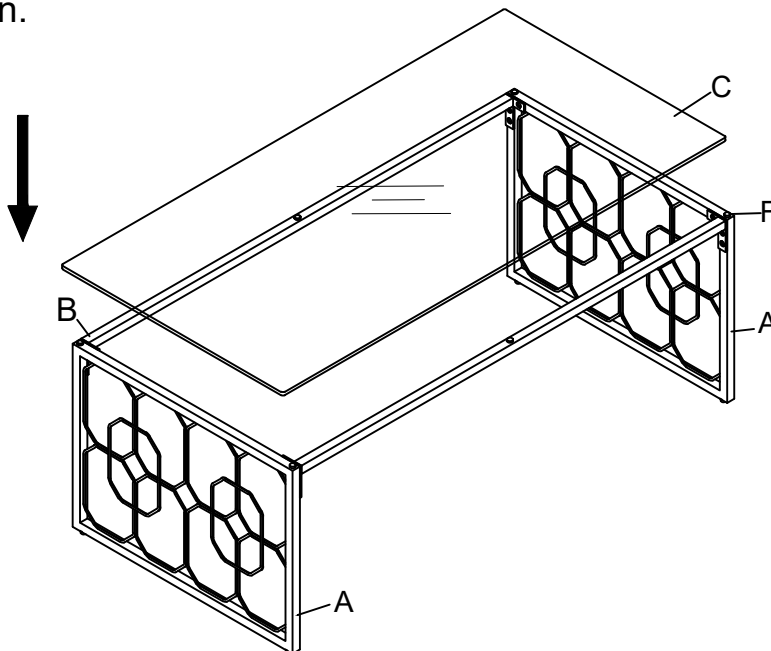

Adjust any parts out of alignment and tighten all bolts and screws from steps 1 through 4.

Cleaning & Care

Treat surface with care. Surface is resistant to scratches but is not scratch resistant. Clean surfaces with a dry or damp soft cloth. Do not use abrasive cleaners. Hardware may loosen over time. Periodically check that all connections are tight.