

# ASSEMBLY INSTRUCTION

## DINING TABLE WITH RATTAN ACCENT SHELF

**A** Table Top

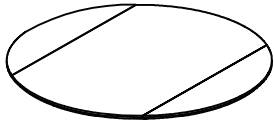

1 pc

**B** Shelf

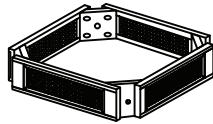

1 pc

**C** Leg



4 pcs

**D** Bolt  
5/16" x 2-1/2"



8 pcs

**E** Lock Washer  
5/16"



8 pcs

**F** Flat Washer  
5/16" x 22mm



8 pcs

**G** Allen Wrench  
M4



1 pc

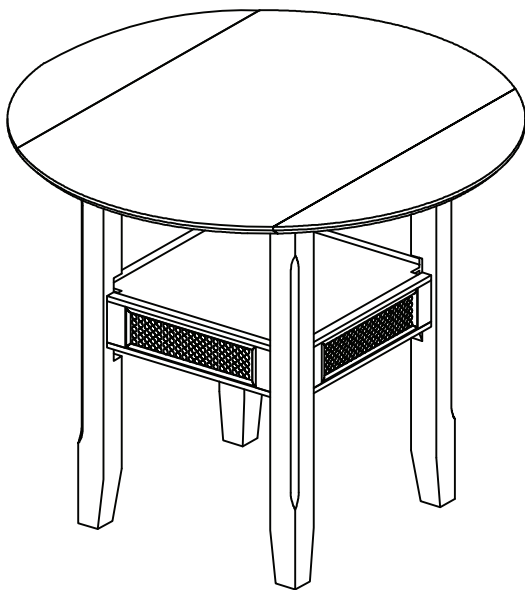

This page lists all the contents included in the box. Please take the time to identify the hardware as well as the individual components to this product. As you unpack and prepare for assembly, place the contents on a carpeted or padded area to protect them from damage.

**1**

Place the Table Top (A) upside down on a smooth carpeted surface. Unfold the table leaf and lock up the leaf support from the table top.

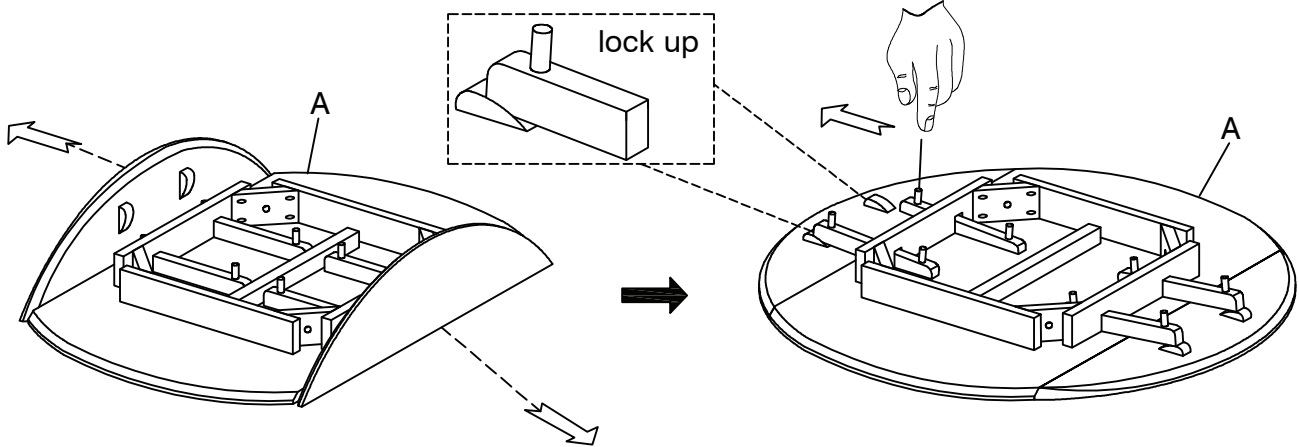
**2**

Attach the Leg (C) to the Shelf (B) using Bolt (D), Lock Washer (E) and Flat Washer (F) with Allen Wrench (G).

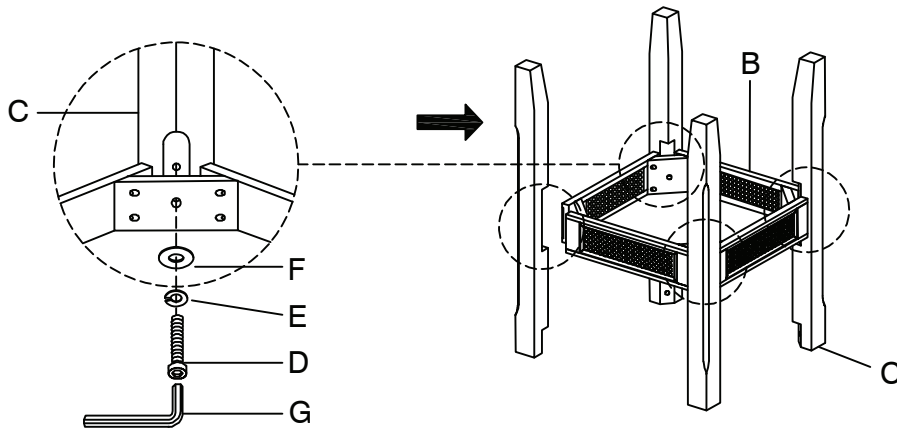
**3**

Attach the Leg (C) to the Table Top (A) using Bolt (D), Lock Washer (E) and Flat Washer (F) with Allen Wrench (G).

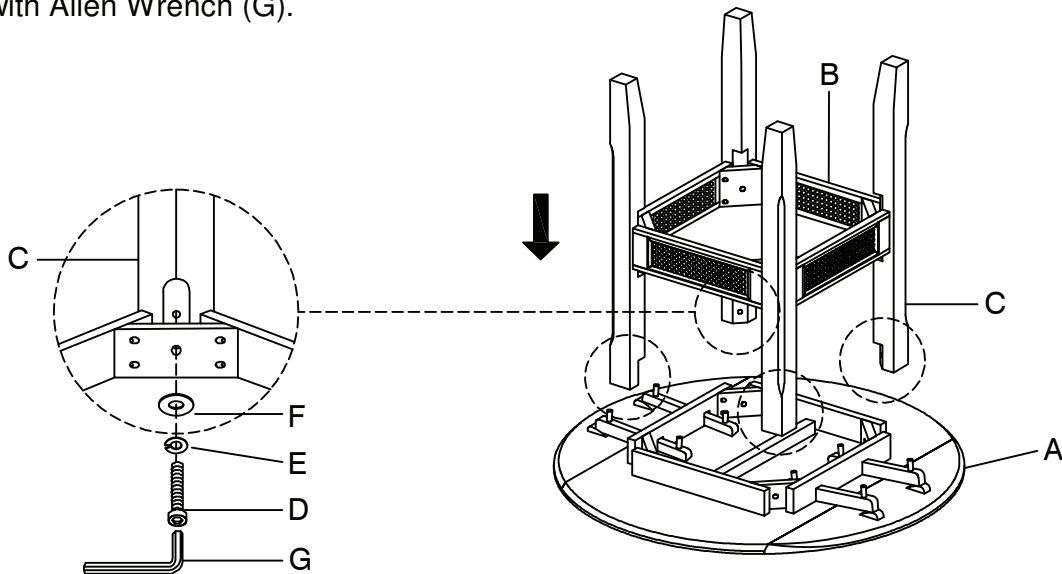

### Cleaning & Care

Treat surfaces with care. Surfaces are resistant to scratches but are not scratch resistant. Clean surfaces with a dry or damp soft cloth. Do not use abrasive cleaners. Hardware may loosen over time. Periodically check that all connections are tight.