

Top view
Scale: 1:1

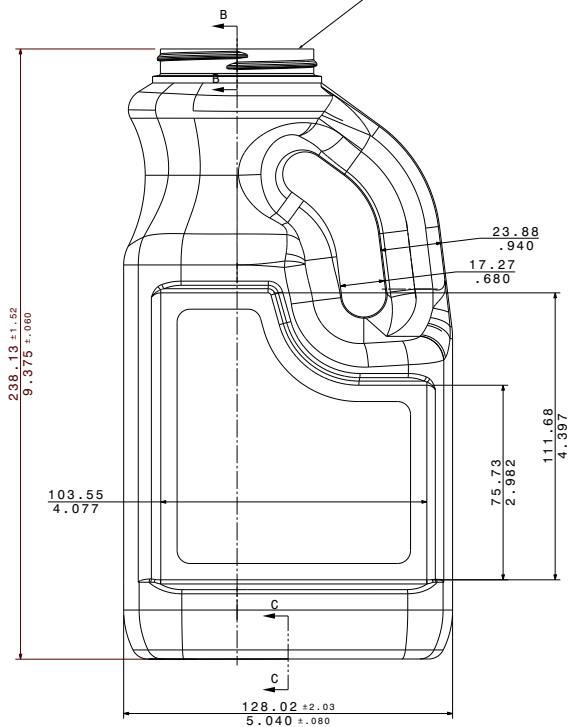

Front view
Scale: 1:1

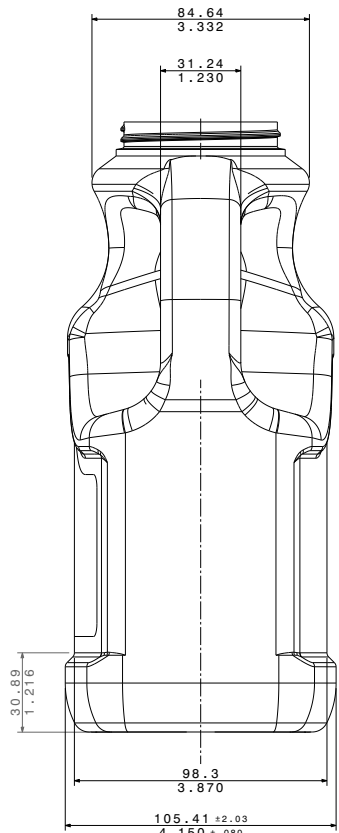

Right view
Scale: 1:1

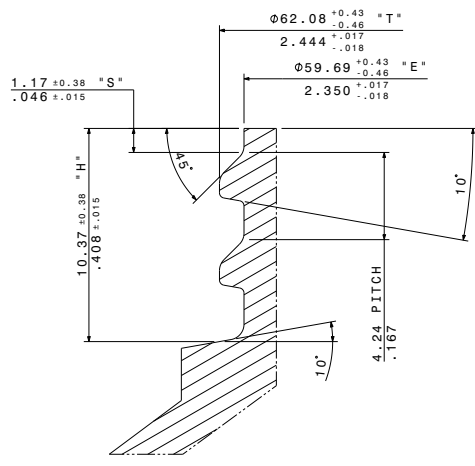

Section cut B-B
Scale: 8:1

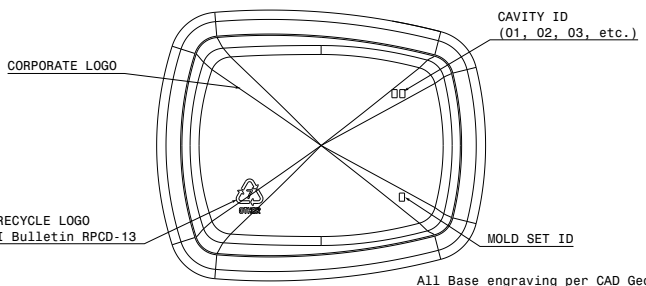

Bottom view
Scale: 1:1

All Base engraving per CAD Geometry
Recessed in mold 0.25mm / .010",
raised on container

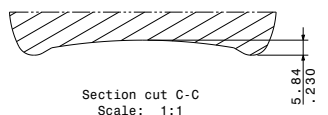

Section cut C-C
Scale: 1:1

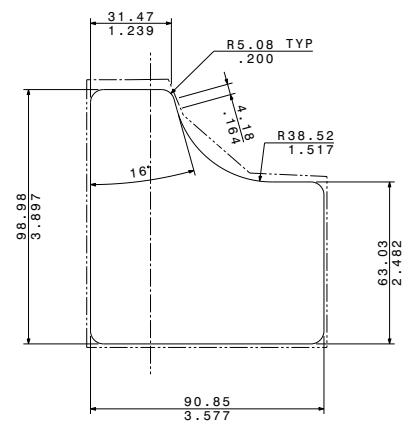

LABEL DETAIL
(RECOMMENDED)
Scale: 1:1



Isometric view
Scale: 1:1

DISCLAIMER

THIS INFORMATION IS PROVIDED AS A GENERAL GUIDE, INCLUDING DIMENSIONS. IT IS THE CUSTOMER'S RESPONSIBILITIES TO SELECT THE PROPER CONTAINER FOR PRODUCT AND APPLICATION COMPATIBILITY.

DISTRIBUTED BY:



REF NO.:

DESCRIPTION:

64 oz PP Econolite II Hot Fill, 63-400, 90 Gram