

Item#	Material	Thickness	Bright of finish
TOPR25WC	White Carrara Marble	25mm	90%
TOPR25BG	Black Granite	25mm	90%
TOPR25WQ	White Quartz	18mm	90%
TOPR25GQ	Grey Quartz	18mm	90%
TOPR25MG	Grey Marble	18mm	90%
TOPR25LS	Blue Limestone	25mm	20-30%
TOPR25CQ	Calacatta Vienna Quartz	18mm	

THIRD ANGLE PROJECTION		hardware resources [®]			
MATERIAL	FINISH				
		TOPR25		A	
DRAWN BY	DATE				
Tony.huang	5-15-2024				
DESIGNED BY	DATE	DRAWING NUMBER		REV	
APPROVED BY	DATE	SIZE	RELEASE LEVEL		
		A3	SCALE 1:1	SHEET	1 OF 1

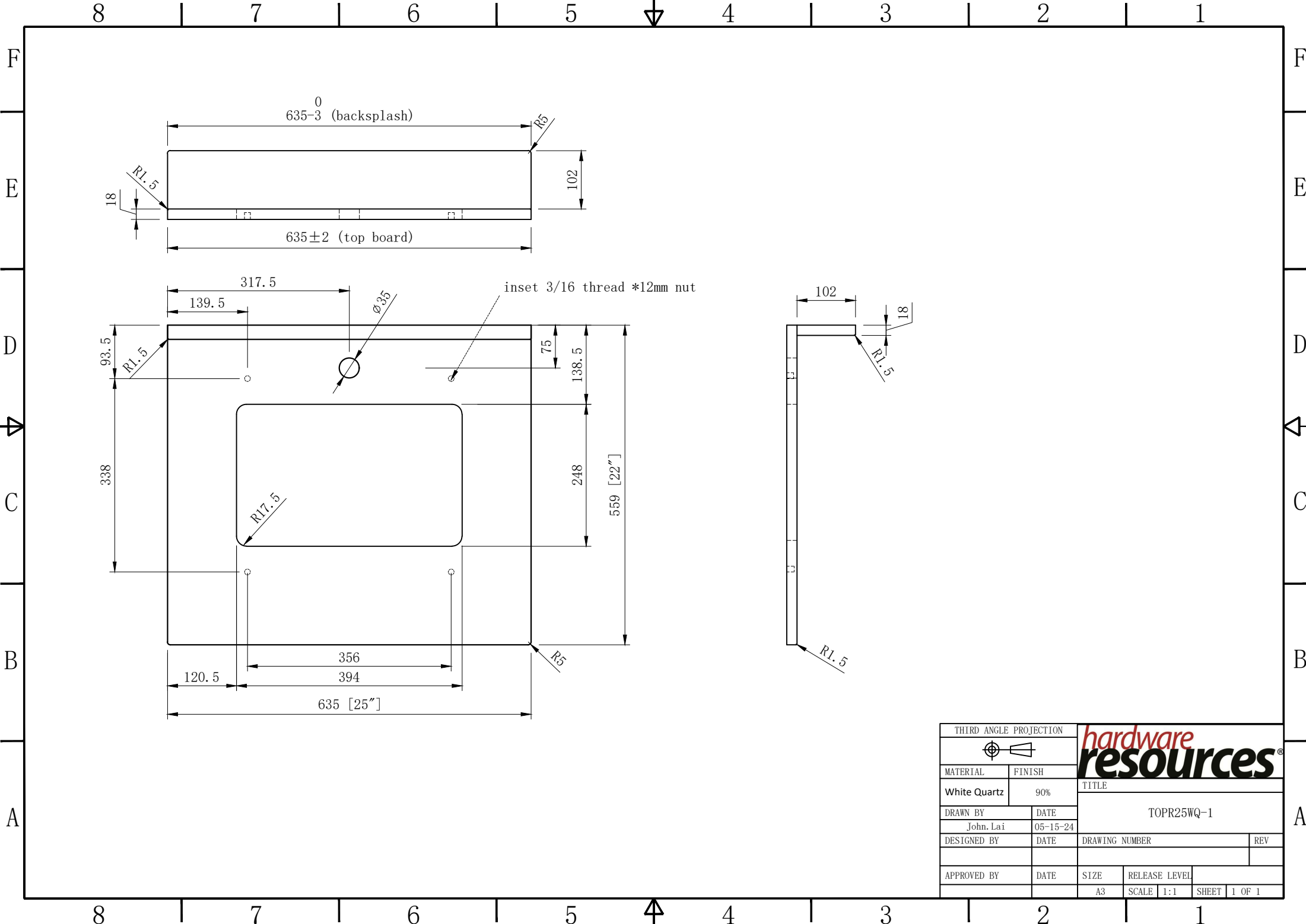

THIRD ANGLE PROJECTION					
MATERIAL	FINISH	TITLE			
White Quartz	90%	TOPR25WQ-1			
DRAWN BY	DATE	DRAWING NUMBER		REV	
John. Lai	05-15-24				
DESIGNED BY	DATE				
APPROVED BY	DATE	SIZE	RELEASE LEVEL		
		A3	SCALE 1:1	SHEET	1 OF 1

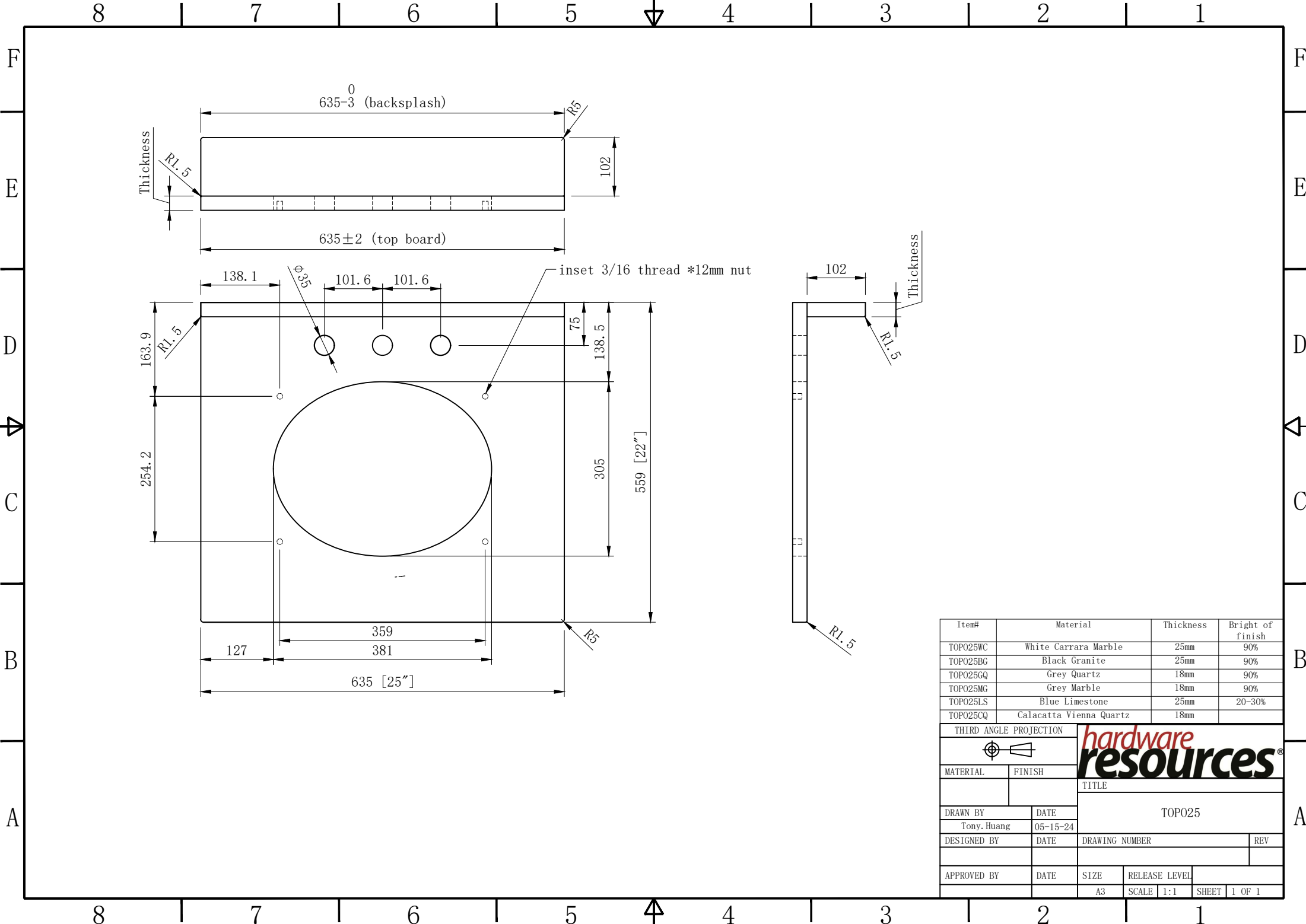

Item#	Material	Thickness	Bright of finish
TOPO25WC	White Carrara Marble	25mm	90%
TOPO25BG	Black Granite	25mm	90%
TOPO25GQ	Grey Quartz	18mm	90%
TOPO25MG	Grey Marble	18mm	90%
TOPO25LS	Blue Limestone	25mm	20-30%
TOPO25CQ	Calacatta Vienna Quartz	18mm	

THIRD ANGLE PROJECTION				hardware resources [®]			
MATERIAL		FINISH					
DRAWN BY		DATE		TOP025			
Tony. Huang		05-15-24					
DESIGNED BY		DATE		DRAWING NUMBER		REV	
APPROVED BY		DATE		SIZE	RELEASE LEVEL		
				A3	SCALE 1:1	SHEET	1 OF 1

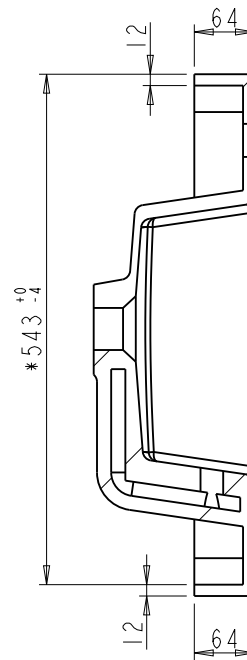
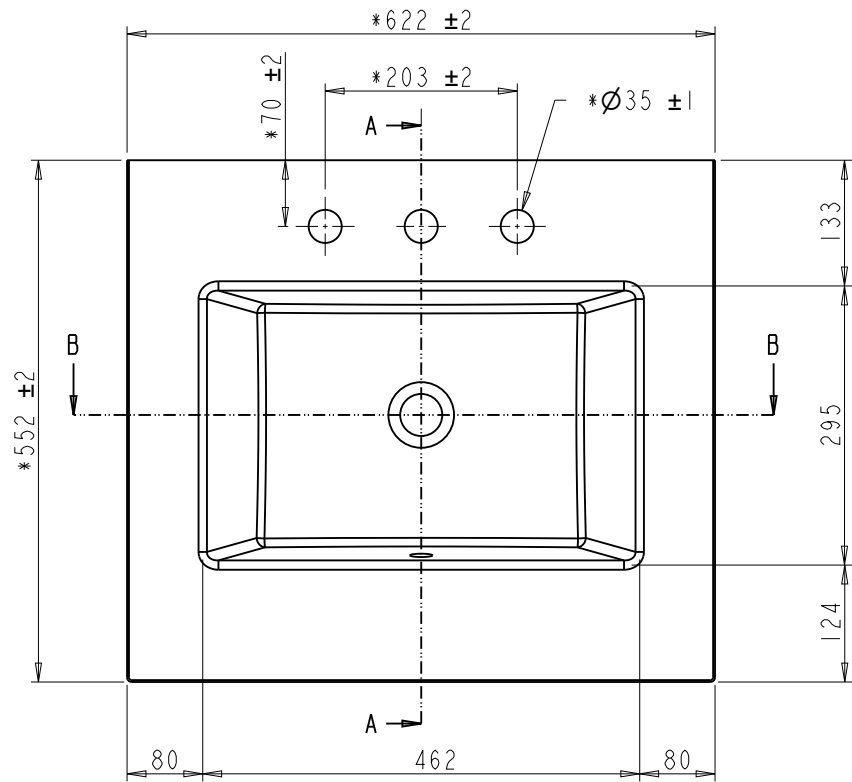

SECTION A-A

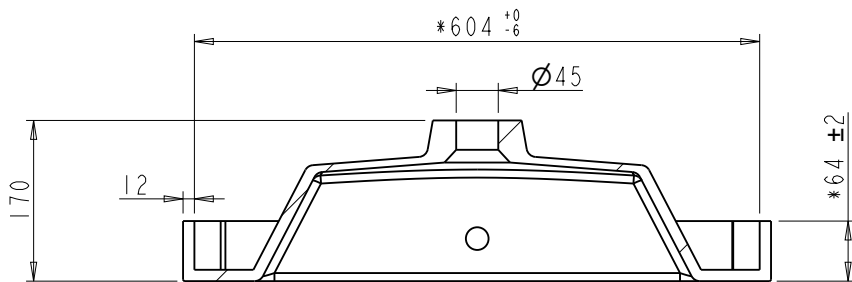
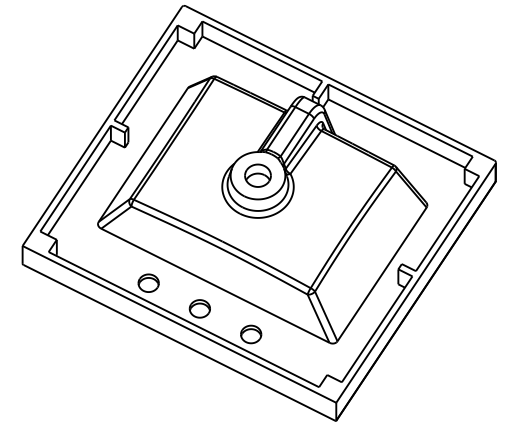
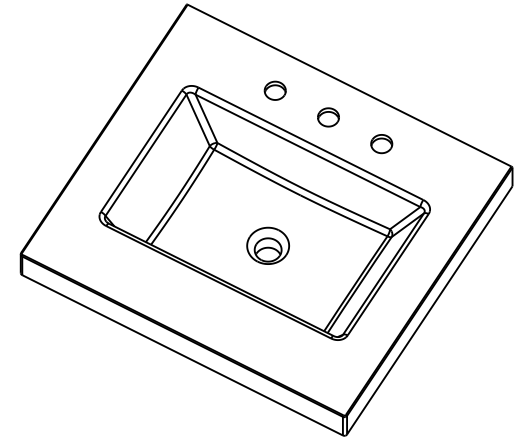

SECTION B-B

	ITEM:	TOPR25RE		MATERIAL:	
	FINISH:			WEIGHT:	
PROPRIETARY AND CONFIDENTIAL THE INFORMATION CONTAINED IN THIS DRAWING IS THE SOLE PROPERTY OF HARDWARE RESOURCES INC. ANY REPRODUCTION IN PART OR AS A WHOLE WITHOUT THE WRITTEN PERMISSION OF HARDWARE RESOURCES INC. IS PROHIBITED.	TOLERANCE UNLESS OTHERWISE SPECIFIED: X ± 0.20 X.X ± 0.10 X.XX ± 0.05 ANGULAR: $\pm 0.5^\circ$		UNITS:	DRAWN BY:	DATE:
	DO NOT SCALE DRAWING		SIZE:	APPROVED BY:	DATE:
			SHEET:	RELEASE LEVEL:	REVISION:
			PROJECTOR		
			Hugo.cai Apr - 14 - 23		
			9		