

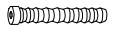

HEKMAN®

A HOWARD MILLER COMPANY

ASSEMBLY INSTRUCTION FOR 23707 CHAIR SIDE TABLE

HARDWARE LIST

NO.	ITEM	DESCRIPTIN	QTY.
1		JCB Bolt M6 X 20MM	12
2		Flat washer M6X18 MM	12
3		Allen wrench	1

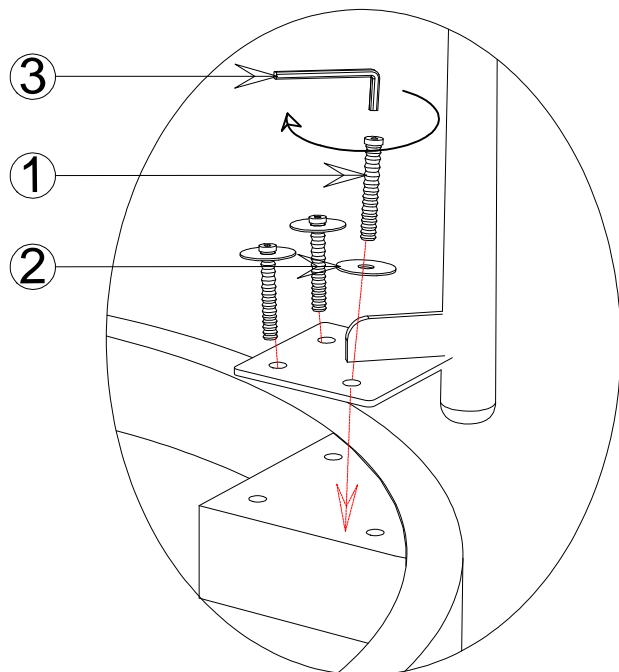
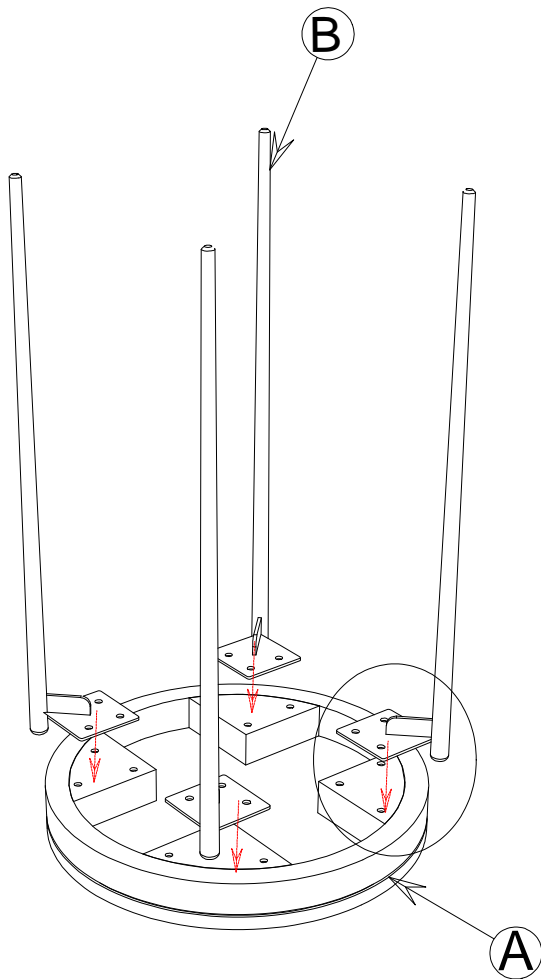
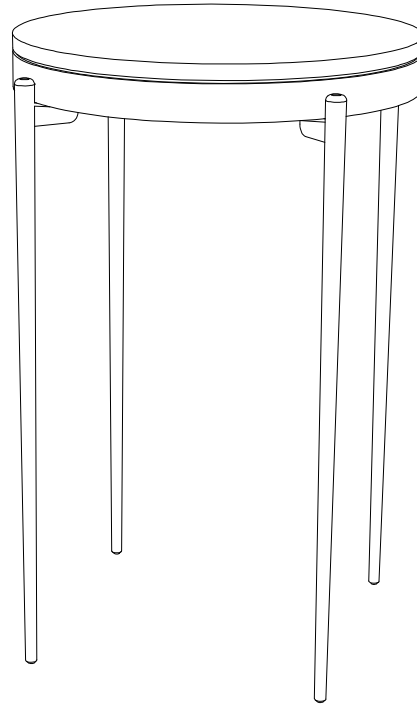

TO ASSEMBLY :

STEP 1 : Unpack chair side table and turn the top (A) upside down .

STEP 2 : Align holes in legs (B) with holes on bottom of top (A) and slide it into position.

STEP 3 : Thread the flat washer(2) , JCB bolt (1) to leg (B) . Do not tighten end assemblies fully.

STEP 4 : Tighten bolts in step 3 fully with allen wrench (3) then carefully turn the table upright.