

13-Gallon EZ STOR® Container with Hinged Cover

Multiple Uses

Dry Products

Product Codes

Container: E139

Description: 13-gallon rectangular can

Cover: E8DH

Description: Dry seal, tamper-evident, hinged, EZ open & close cover

Features

Built in hand grips
 Gauge: 90 mil.
 Nominal capacity: 13 USG / 49.2 L
 Stack performance: 200 lbs.*
 Tare weights: Body: 4.06 lbs. / 1.84 kgs.
 Cover: .66 lbs. / .3 kgs.

Note: *Ratings will be reduced with uneven load distribution.

Specifications with Cover

Dimensions: 16-5/16" L X 13-1/2" W X 18-11/16" H
 Maximum capacity: 13.4 USG / 50.7 L
 Tare weight: 4.72 lbs. / 2.14 kgs.

Colors

Standard: White, Black and Natural
 Custom: Available at manufacturer's discretion

Decorating Options*

Silk-Screen**
 Pressure sensitive labels: 8"W X 7"H
 Logo emboss for cover: 7-3/4"W X 4"H

Note: *See EZ Stor Decoration Summary for further details.

**Where available.

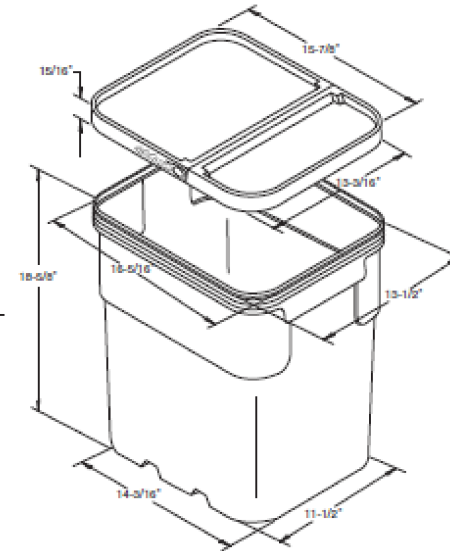

Shipping Data

	Bodies	Covers
Qty. per pallet:	45	1,215 (45 boxes of 27)*
Weight (lbs./kgs.)**:	182.7/82.8	801.9/364.5
Den. (lbs./C.F./kgs./m3):	3.5/56.7	7.2/115.7
Length (in./cm.):	49.0/124.5	51.0/129.5
Width (in./cm.):	40.5/102.9	42.0/106.7
Height (in./cm.):	45.0/114.3	90.0/228.6

Estimated truckload quantity of 2,340 bodies and covers***

Filled Containers

18 (9 per layer / 2 layers high)Gross
 Pallet height: 42.5"

Notes: *Bulk pack also available
 **Weight does not include pallet / packaging
 ***Truckload quantity based on 53' trailer

Materials

FDA approved materials
 Resin: Body: High Density Polyethylene (HDPE)
 Cover: Polypropylene (PP)
 MSDS Sheets available upon request

DISCLAIMER

THIS INFORMATION IS PROVIDED AS A GENERAL GUIDE, INCLUDING DIMENSIONS. IT IS THE CUSTOMER'S RESPONSIBILITIES TO SELECT THE PROPER CONTAINER FOR PRODUCT AND APPLICATION COMPATIBILITY.

DISTRIBUTED BY:



REF NO.:

DWG10148

DESCRIPTION:

13 gallon HDPE EZ Stor Pail