

# Goalrilla™

## 60" BASKETBALL SYSTEM

MODEL NO.  
**B3016**



**Please Do Not Return This  
Product to the Store!**

Contact Escalade® Sports customer service department at:  
Phone: 1-888-USA-GOAL Toll-Free!  
Fax: 1-866-873-3536 Toll-Free!  
E-mail: [customerservice@escaladesports.com](mailto:customerservice@escaladesports.com)

**ESCALADE®**  
SPORTS

Escalade® Sports products may be manufactured and/or licensed under the following patents.  
6120397, 5816957, 5769744, 5119741, 4911085, 4717157, D460140, D420563, 8414431  
Additional patents may be pending. One or more of the listed patents and/or pending patents may cover specific product.

2L-7629-00

2017 Escalade® Sports

# PRE - ASSEMBLY TIPS

1. **Read this manual carefully before starting assembly.** Read each step completely before beginning each step.
2. **Some smaller parts may be shipped inside larger parts. Check inside all parts and cartons before assembling or ordering parts.**
3. **To make assembly easier, use the Hardware Identifier on page 6 to identify and sort all fasteners. Check all cartons for kits. All hardware may not be located in one kit.**
4. **Do not tighten hardware until instructed to do so. If hardware is tightened too soon, mounting holes may not align and parts may not easily fit together. Leave locknuts slightly loose until you are instructed to tighten them.**
6. **An electric screwdriver is helpful in assembly. However, please set at low torque and use caution because you could overtighten the hardware and strip the screws.**
5. **Save these instructions and your proof of purchase (receipt) in the event that the manufacturer has to be contacted for replacement parts.**

**Tools required for assembly:**

- |  |                                     |
|--|-------------------------------------|
| 1 - 3/8" Drive Ratchet                   | 1 - Phillips Screwdriver            |
| 1 - 15/16" open end wrench               | 1 - Level                           |
| 1 - 15/16" socket and ratchet (optional) | 1 - Tape Measure                    |
| 1 - 9/16" Deep Well Socket & Ratchet     | 1 - Rubber Mallet                   |
| 1 - 3/4" Socket & Ratchet                | 1 - Set of Padded Saw Horses        |
| 1 - 3/4" Open end Wrench                 | 1 - 5/16" Hex Key Socket (included) |

**Please Do Not Return This Product To The Store!**

Contact Escalade® Sports customer service department at:

Phone: 1-888-USA-GOAL Toll – Free !

Fax: 1-866-873-3536 Toll – Free !

E-mail: basketball@escaladesports.com

Mailing Address (correspondence only):

Escalade Sports

PO Box 889

Evansville, IN 47706

To view a video showing how to install the anchor system on page 9, please visit our YouTube page at:

<https://www.youtube.com/watch?v=mwxdkTqS5ac>

or scan with your smart phone.

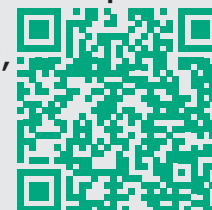

Please visit our Website at:  
[www.escaladesports.com](http://www.escaladesports.com)

ON-LINE TROUBLE SHOOTING TECHNICAL ASSISTANCE  
ON-LINE PARTS REQUESTS FREQUENTLY ASKED QUESTIONS  
ADDITIONAL ESCALADE® SPORTS PRODUCT INFORMATION





# SAFETY INSTRUCTIONS



**FAILURE TO FOLLOW THESE WARNINGS MAY RESULT IN SERIOUS INJURY AND/OR PROPERTY DAMAGE.**

**Owner must ensure that all players know and follow these rules for safe operation of the system.**



## WARNING

**FAILURE TO FOLLOW THESE WARNINGS MAY RESULT IN SERIOUS INJURY AND/OR PROPERTY DAMAGE.**

**Owner must ensure that all players know and follow these rules for safe operation of the system.**

- Only hang from the rim briefly to regain balance or avoid injuring others. Release the rim as soon as safely possible.
- During play, especially when performing dunk type activities, keep player's face away from the backboard, rim, and net. Serious injury could occur if teeth/face come in contact with backboard, rim, or net.
- Do not slide, climb, or play on pole.
- When adjusting height, keep hands and fingers away from moving parts.
- Do not allow children to adjust system.
- During play, do not wear jewelry (rings, watches, necklaces, etc.) Objects may entangle in net.
- Keep water and organic material away from pole. Pole can rust and fail.
- Once a month check pole and all metal parts for rust. Completely remove rust and repaint with exterior enamel. If rust has penetrated any steel part, replace that part immediately.
- Check system before each use for loose hardware, signs of rust and instability. Repair before each use. Never play on damaged equipment.
- Wear a mouthguard when playing to avoid dental injuries.



## SAFETY INSTRUCTIONS



**FAILURE TO FOLLOW THESE SAFETY INSTRUCTIONS MAY RESULT IN SERIOUS INJURY, PROPERTY DAMAGE AND WILL VOID WARRANTY.**

**Owner must ensure that all players know and follow these rules for safe operation of the system.**

**To ensure safety, do not attempt to assemble this system without following the instructions carefully. Proper and complete assembly, use and supervision is essential for proper operation and to reduce the risk of accident or injury. A high probability of serious injury exists if this system is not installed, maintained, and operated properly.**

- If using a ladder during assembly, use extreme caution.
- 4 people are recommended for this operation.
- Seat the pole sections properly (if applicable). Failure to do so could allow the pole sections to separate during play.
- Before digging contact utility company to locate underground power cables, gas and water lines. Ensure there are no overhead power lines within 20 ft. (7m) radius of pole location.
- Climate, corrosion or misuse could result in system failure.
- If technical assistance is required, contact the manufacturer.
- Minimum operational height is 6'6" (1.98m) to the bottom of backboard.

*Most injuries are caused by misuse and/or not following instructions.  
Use caution when using this system.*

## WARNING!

**Failure to observe this warning may cause property damage and/or serious injury.**

(Affixed to backboard)

Only hang from the rim briefly to regain balance or avoid injuring others. Release the rim as soon as safely possible.  
Rim height adjustments should be made under parental supervision.  
Wear a mouth guard when playing to avoid dental injuries.  
During play, do not wear jewelry (rings, watches, necklaces, etc).  
Objects may entangle in net.

**PARTS LIST (NOT ACTUAL SIZE)**

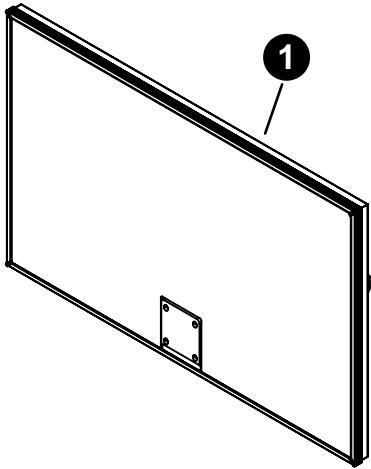

**BACKBOARD**  
6A-7705-00  
(QTY. 1)

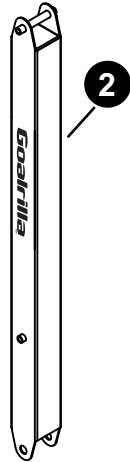

**LOWER BOARD ARM**  
1A-7930-00  
(QTY. 1)

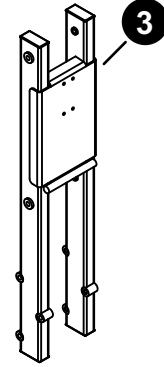

**UPPER POLE**  
1A-7929-00  
(QTY. 1)

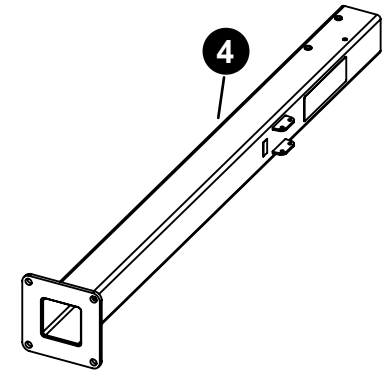

**LOWER POLE**  
1A-7928-00  
(QTY. 1)

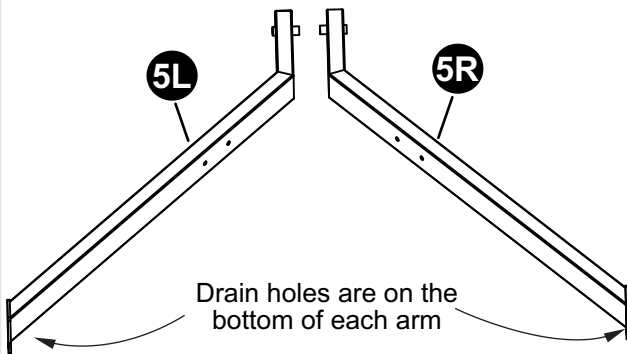

**UPPER BOARD ARM - LEFT**  
1A-7931-00  
(QTY. 1)

**UPPER BOARD ARM - RIGHT**  
1A-7931-00  
(QTY. 1)

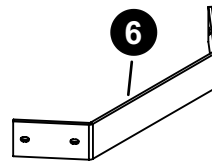

**UPPER BOARD ARM BRACE**  
2S-9318-00  
(QTY. 1)

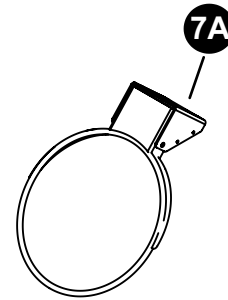

**GOAL ASSEMBLY**  
6A-6328-02  
(QTY. 1)

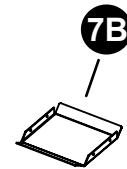

**RIM COVER PLATE**  
2S-6241-00  
(QTY. 1)

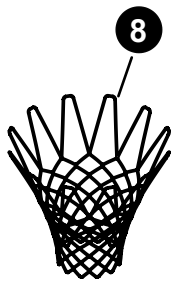

**NET**  
3F-6010-00  
(QTY. 1)

## PARTS LIST (NOT ACTUAL SIZE)

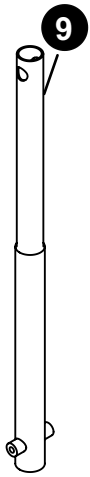

**9**  
**ACTUATOR HANDLE**  
 4A-6550-01  
**(QTY. 1)**

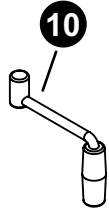

**10**  
**PULL PIN**  
 7B-6255-00  
**(QTY. 1)**

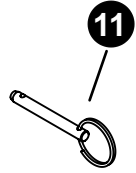

**11**  
**ACTUATOR BUSHING**  
 8S-7937-00  
**(QTY. 2)**



**12**  
**POST BRACKET**  
 2S-6794-00  
**(QTY. 2)**

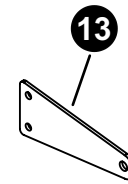

**13**  
**HEIGHT DECAL**  
 4L-8266-00  
**(QTY. 1)**  
**Note:** Packed with the instructions manual.

**ACTUATOR**  
 4A-8163-00  
**(QTY. 1)**

## PRE-ASSEMBLED PARTS

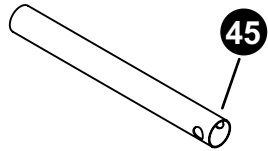

**45**  
**ACTUATOR SLEEVE**  
 2M-6833-00  
**(QTY. 1)**



**46**  
**ACTUATOR CAP**  
 3M-6467-00  
**(QTY. 1)**

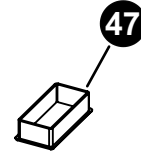

**47**  
**1 9/16 X 3 1/8 TUBE CAP**  
 3M-6834-00  
**(QTY. 6)**

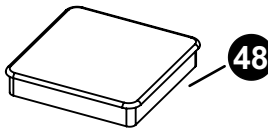

**48**  
**6X6 TUBE CAP**  
 3M-6838-00  
**(QTY. 1)**

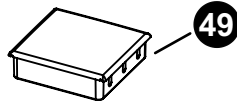

**49**  
**CAP, (LOWER BOARD ARM)**  
 3M-9038-00  
**(QTY. 2)**

HARDWARE IDENTIFIER (ACTUAL SIZE)

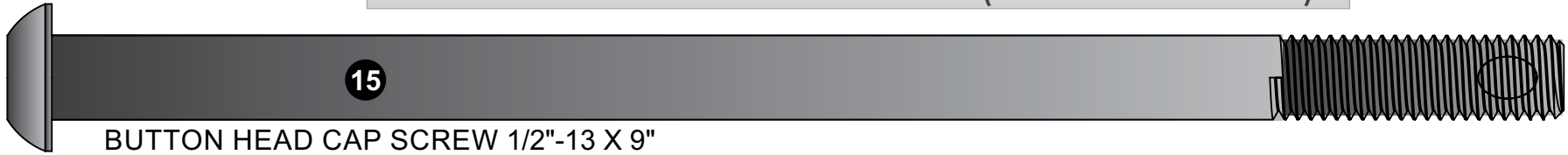

15  
BUTTON HEAD CAP SCREW 1/2"-13 X 9"  
1B-7134-00  
(QTY. 2)



16  
BUTTON HEAD CAP SCREW 1/2"-13 X 8 1/4"  
1B-7130-00  
(QTY. 3)



17  
1/2-13 X 7 3/4" HEX BOLT  
1B-7133-00  
(QTY. 1)



18  
5/8"-11 x 5 1/2" HEX HEAD BOLT  
1B-7137-00  
(QTY. 1)

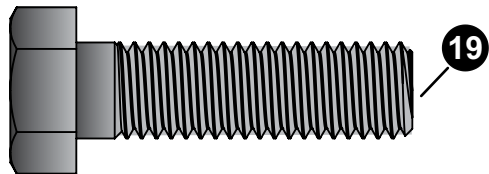

19  
1/2-13 X 1 3/4" HEX BOLT  
1B-6944-10  
(QTY. 2)

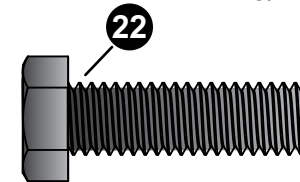

22  
3/8-16 X 1 1/4" HEX BOLT  
1B-6936-10  
(QTY. 4)



20  
3/8-16 X 2 9/16" HEX BOLT  
1B-7131-00  
(QTY. 4)

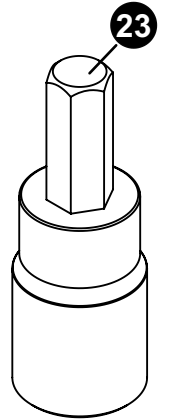

23  
5/16" HEX KEY SOCKET  
3/8" DRIVE  
7B-6509-00  
(QTY. 1)

# HARDWARE IDENTIFIER (ACTUAL SIZE)

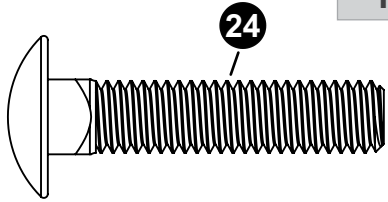

3/8-16 X 1 3/4" CARRIAGE BOLT  
1B-6782-10  
(QTY. 4)

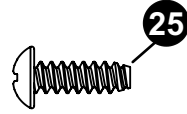

#8 X 1/2" THREAD FORMING SCREW  
1B-6238-01  
(QTY. 4)

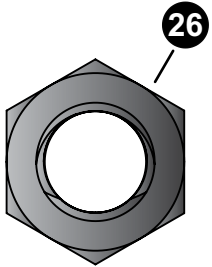

5/8-11 HEX NYLON LOCK NUT  
1B-7139-00  
(QTY. 1)

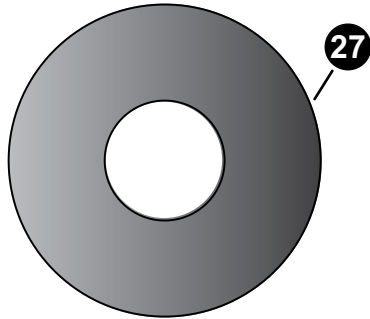

1-5/8" OD, 5/8" ID WASHER  
1B-7138-00  
(QTY. 2)

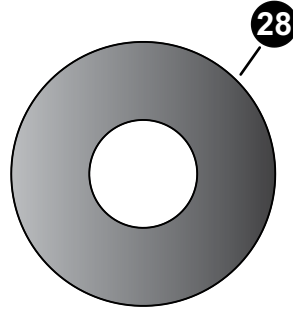

1/2" FLAT WASHER  
2B-6093-10  
(QTY. 6)

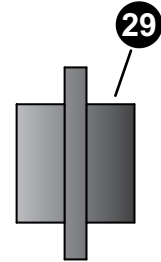

TWO WAY STEP BUSHING  
7B-6439-00  
(QTY. 2)

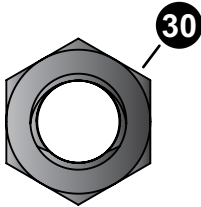

1/2-13 LOCKNUT  
2B-6095-10  
(QTY. 3)

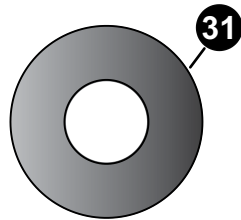

3/8 FLAT WASHER  
2B-6237-10  
(QTY. 20)

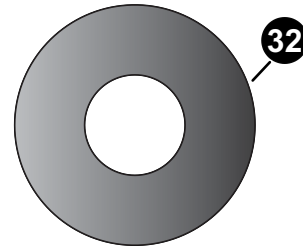

1/2 X 1 1/4" **PLASTIC** WASHER  
3M-6245-00  
(QTY. 10)

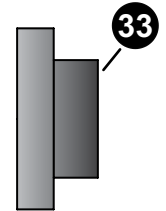

STEP BUSHING  
7B-6391-01  
(QTY. 2)

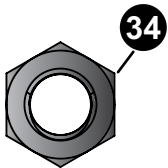

3/8-16 LOCKNUT  
2B-6238-10  
(QTY. 12)

## HARDWARE IDENTIFIER (ACTUAL SIZE)

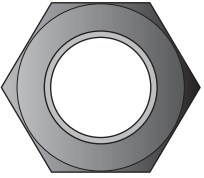

**36**  
5/8"-11 HEX NUT  
2B-6097-02  
(QTY. 12)

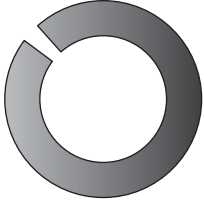

**37**  
5/8" SPLIT LOCK  
WASHER  
2B-6099-02  
(QTY. 4)

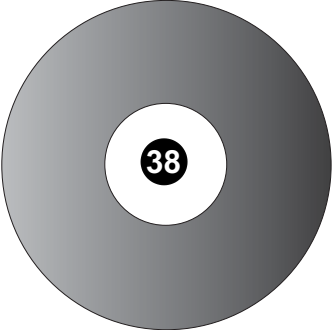

**38**  
5/8" FLAT WASHER  
2B-6098-03  
(QTY. 8)

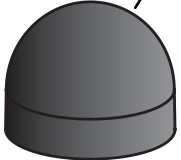

**39**  
5/8" THREAD  
PROTECTOR  
PLASTIC CAP  
3M-9040-00  
(QTY. 4)

**\*Hardware located in Anchor kit box**

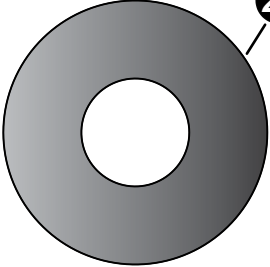

**28**  
1/2" FLAT WASHER  
2B-6093-10  
(QTY. 2)

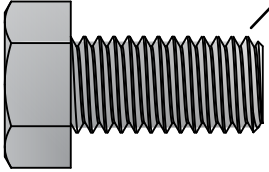

**21**  
1/2-13 X 1" HEX BOLT  
1B-6215-10  
(QTY. 2)

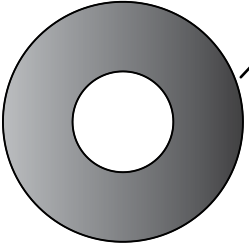

**32**  
1/2" X 1 1/4" **PLASTIC** WASHER  
3M-6245-00  
(QTY. 4)

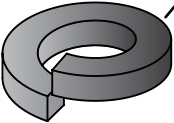

**35**  
1/2 SPLIT LOCK WASHER  
2B-6094-10  
(QTY. 2)

**\*Hardware located in Actuator kit box**

## PARTS LIST (NOT ACTUAL SIZE)

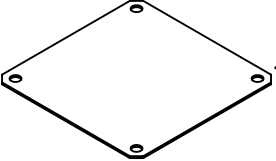

**41**  
ANCHOR PLATE  
2S-6494-00  
(QTY. 1)

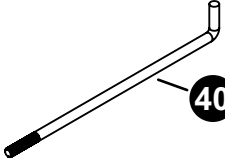

**40**  
5/8"-11 X 18 "J" BOLT  
2B-6096-00  
(QTY. 4)



**42**  
#3 X 40" REBAR  
1S-6152-00  
(QTY. 4)

**\*Parts located in Anchor kit box**



# INSTALLATION TIMELINE

1. Prior to anchor system and goal assembly, call utility services (811) for location of underground utility lines before you dig.
2. Vertical main post assembly is a two part process.

## PART 1

**Day 1.** Complete Anchor System Installation Instructions. (Below)

**Day 2-4.** Allow concrete to cure.

## PART 2

**Day 5.** Complete Goalrilla™ assembly instructions. (Requires four adults)

# ANCHOR SYSTEM INSTALLATION INSTRUCTIONS (Day 1)

## ⚡ WARNING

**Before digging hole for anchor system, check for buried power, gas, water, and telecommunication lines! Failure to do so could result in serious or fatal injury! Contact your local utility company if unsure.**

### Items needed for Anchor Installation (not included)

- |  |                  |
|--|------------------|
| 11 - 80 lb. bags of concrete (2-3 extra recommended) | 1 - wheel barrow |
| 1 - post hole digger (optional)                      | 1 - garden hose  |
| 1 - 15/16" open end wrench                           | 1 - level        |
| 1 - 15/16" socket and ratchet (optional)             | 1 - tape measure |
| 1 - concrete form (see note after step 2)            |                  |

**Note: For best results with less vibration, anchor system should be independent of court. If pouring concrete for both at same time, add an expansion joint in between.**

**Note: When digging hole, if you hit rock and cannot dig through contact a contractor.**

1. Determine the location of the anchor system. The proper location is as **close to the court without making contact**, as shown in Figure 1. This, however, is a general rule. If you need to locate the anchor system in a location other than this, use the following dimensions as a guide.

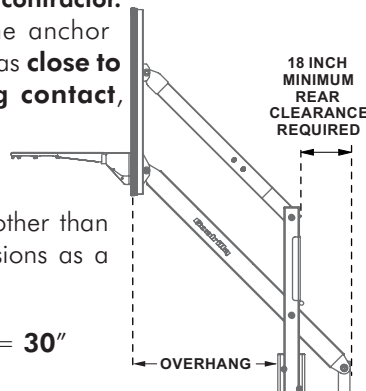

2. Assemble anchor system as follows: Thread nut (#36) to bottom of threads on anchor bolt (#40) insert threads of anchor bolt (#40) through hole on anchor plate (#41) and secure with nut (#36). Repeat this step for the remaining anchor bolts. See Figure 2. Note: Each leg of anchor bolts should face the anchor bolt to the right. See Detail A.

### Detail A Bottom View

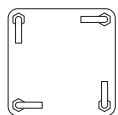

THESE NUTS USED FOR LEVELING

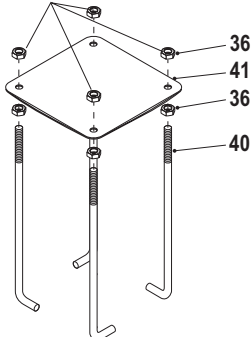

## Figure 2

Figure 1

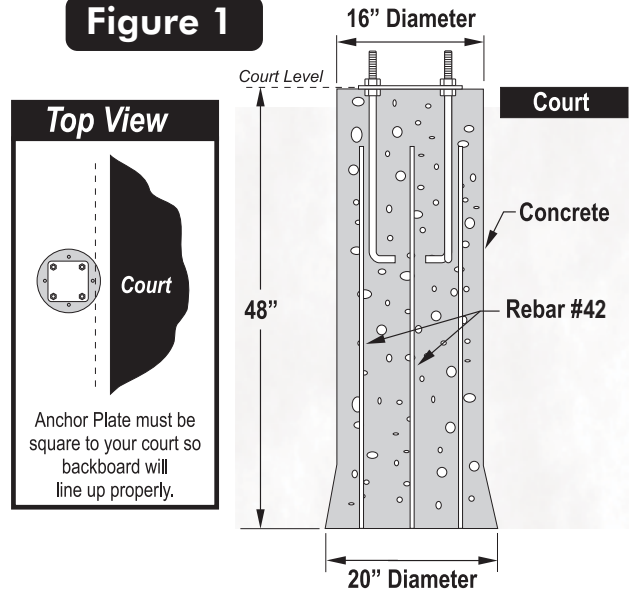

**Note: Using a concrete form for the top 4" of the concrete is recommended. Cardboard forms can be purchased at some hardware and home stores or a wooden form can be constructed out of 2 x 4's.**

**Note: Failure to dig and fill hole as instructed will result in increased system vibration.**

**\*Tip: It is always a good idea to purchase one or two extra bags of concrete, just in case you need them. If extra bags are not used you can return them to the store.**

3. Mix and pour concrete into hole. Follow instructions on concrete bag. Stop about 18" below court level.
4. Insert four reinforcement bars (#42) into concrete 8" apart creating a square in center on hole.
5. Place form in desired location and finish pouring concrete up to court level.
6. Push anchor system into concrete and agitate to work out voids in concrete. Immediately use a level to level and square anchor plate to playing surface. Clean off any concrete that may be on exposed threads.

**Note: The bottom four nuts will be forever embedded in concrete. The top four nuts remain on bolts and are used for leveling. (See Step 10 on page 19)**

Let concrete stand for a MINIMUM of 72 hours.

**NOTE:**

Prepare a flat area that is clear of debris. Keep children away from the assembly area. Two capable adults are needed for the following steps.

**! CAUTION !**  
MAKE SURE THAT THE POLE IS SECURE ON THE SAWHORSES AND NEVER LEAVE IT UNATTENDED.

1. Place Lower Pole 4 on two sawhorses as shown.

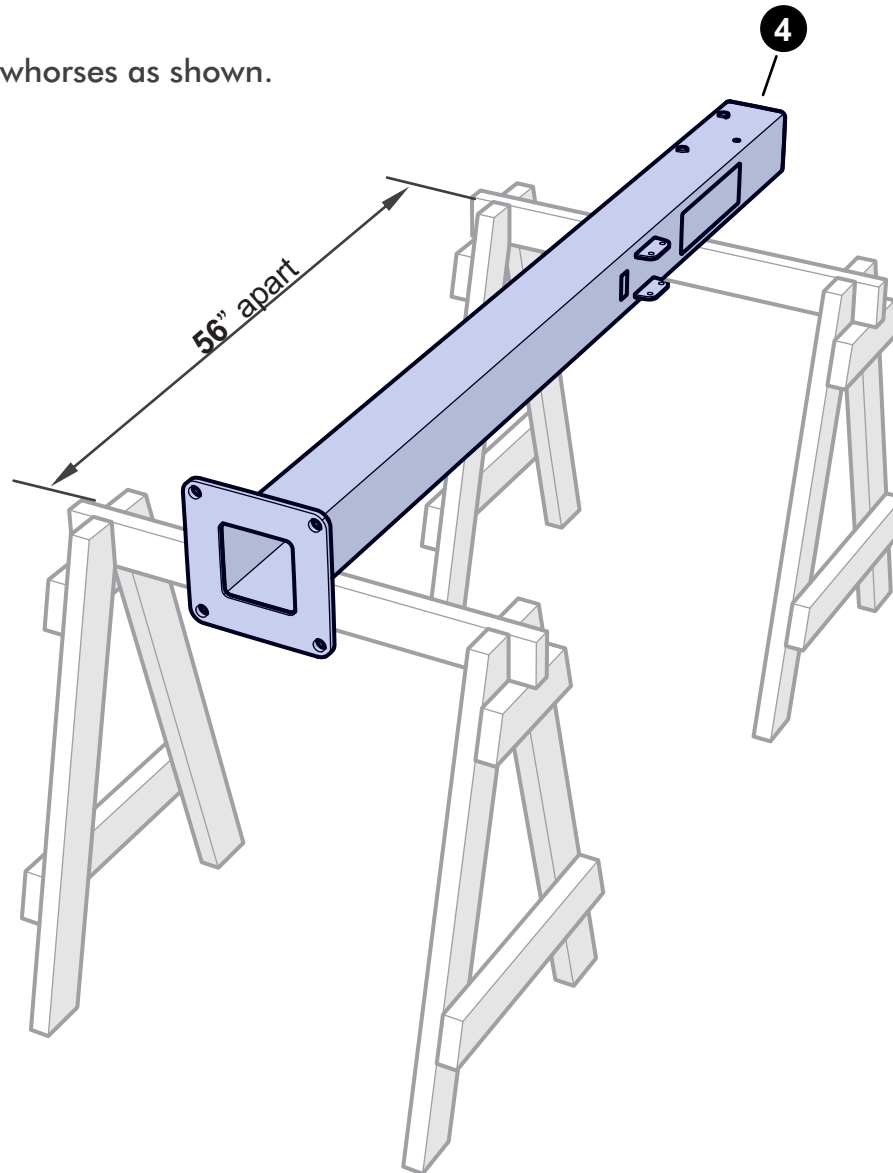

### TOOLS NEEDED

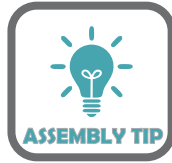
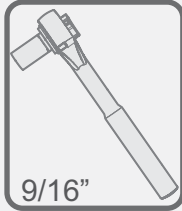

The following pages will have a picture of the **Hardware Needed** along with the Quantity, Part Number and Description. You can lay the hardware on the picture to identify the hardware.

### HARDWARE NEEDED (ACTUAL SIZE)

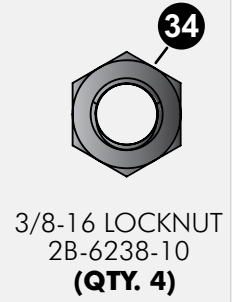
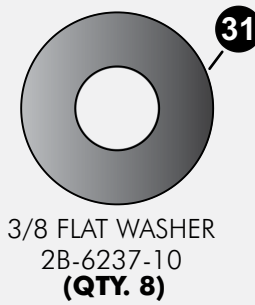
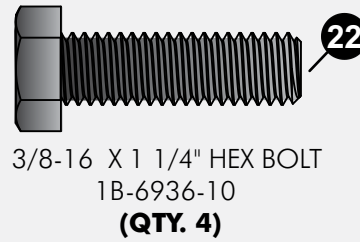

2. Assemble Post Brackets **13** on the outside of welded brackets on back of the post as shown. **Tighten hardware tight.**

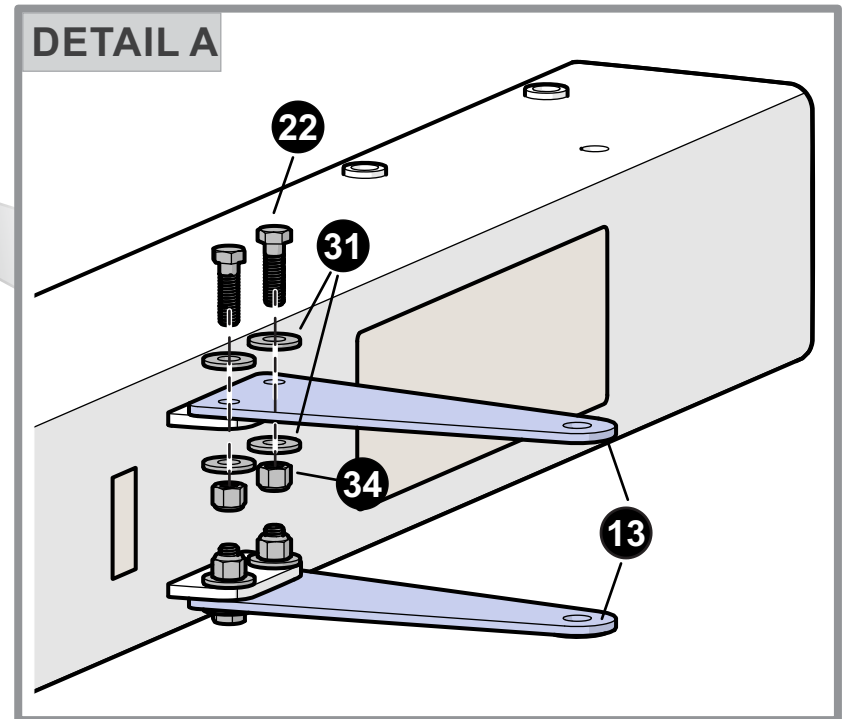
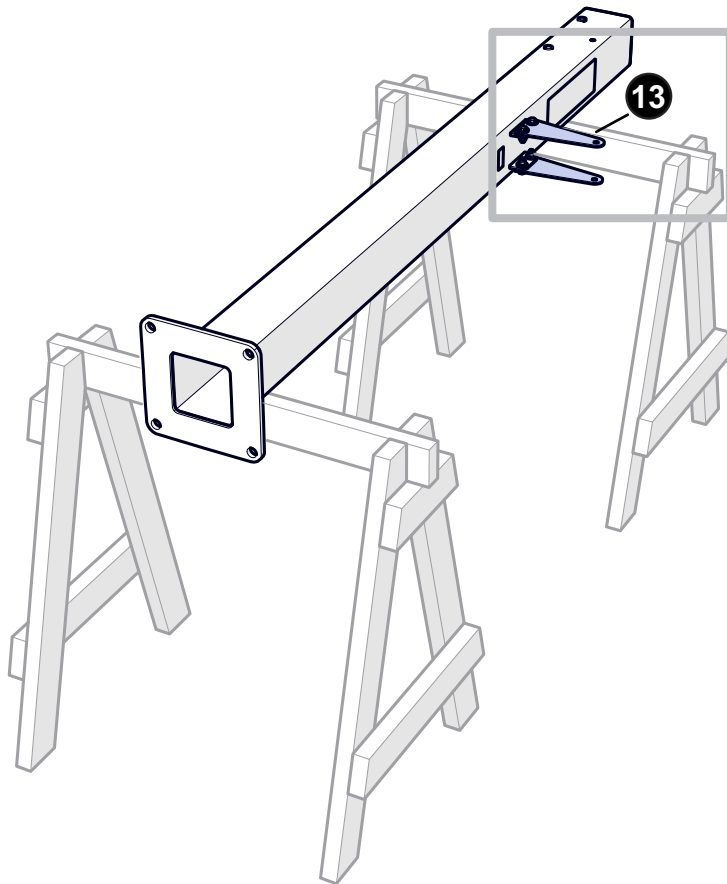

## TOOLS NEEDED

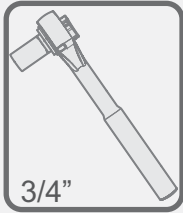
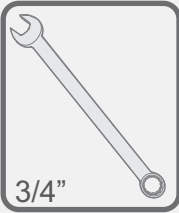

## NOTE

IT IS IMPORTANT FOR THE INSTALLER TO UNDERSTAND THE NECESSITY OF THE PLASTIC WASHERS (#32) PROVIDED. THESE WASHERS ADEQUATELY SPACE PAINTED PARTS AT ALL PIVOT POINTS. NEGLECTING THE USE OF THESE WASHERS WILL RESULT IN RUSTED PARTS.

## HARDWARE NEEDED (ACTUAL SIZE)

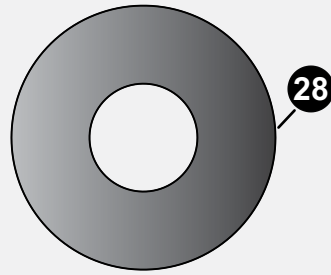

1/2" FLAT WASHER  
2B-6093-10  
(QTY. 2)

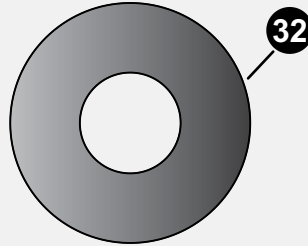

1/2" X 1 1/4" **PLASTIC** WASHER  
3M-6245-00  
(QTY. 4)

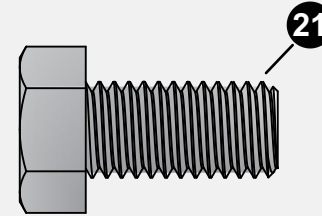

1/2-13 X 1" HEX BOLT  
1B-6215-10  
(QTY. 2)

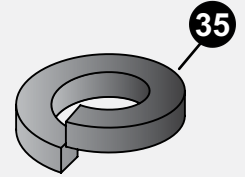

1/2 SPLIT LOCK WASHER  
2B-6094-10  
(QTY. 2)

**\*Hardware located in Actuator kit box**

3. Attach Actuator 9 to brackets as shown in **Detail A**.  
Tighten bolts tight.

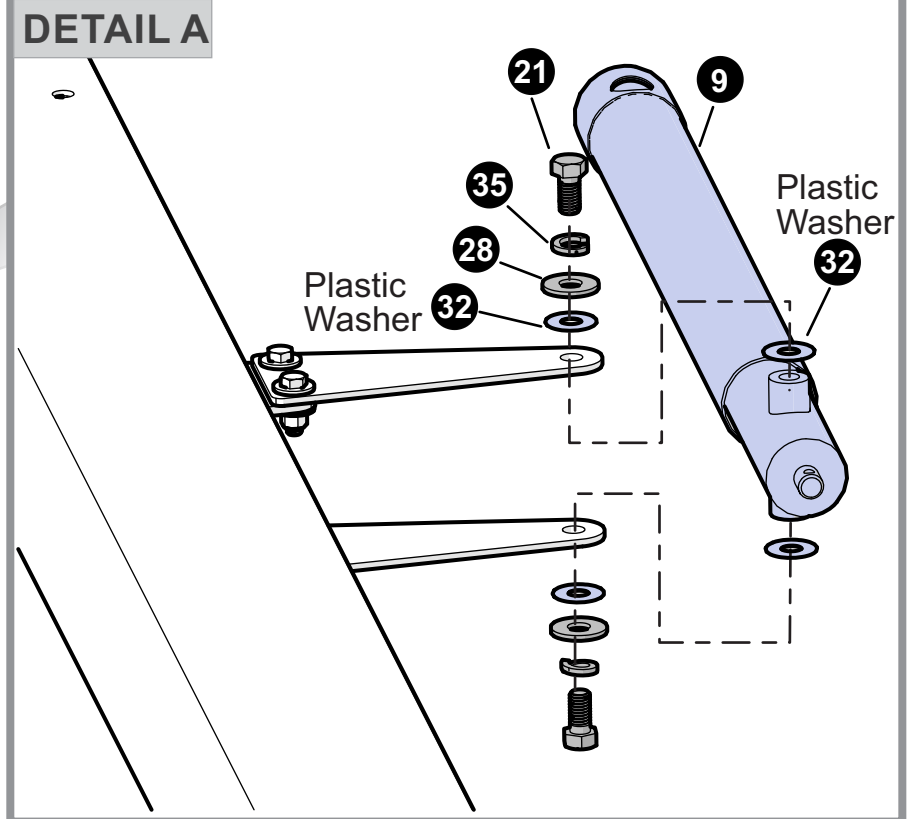
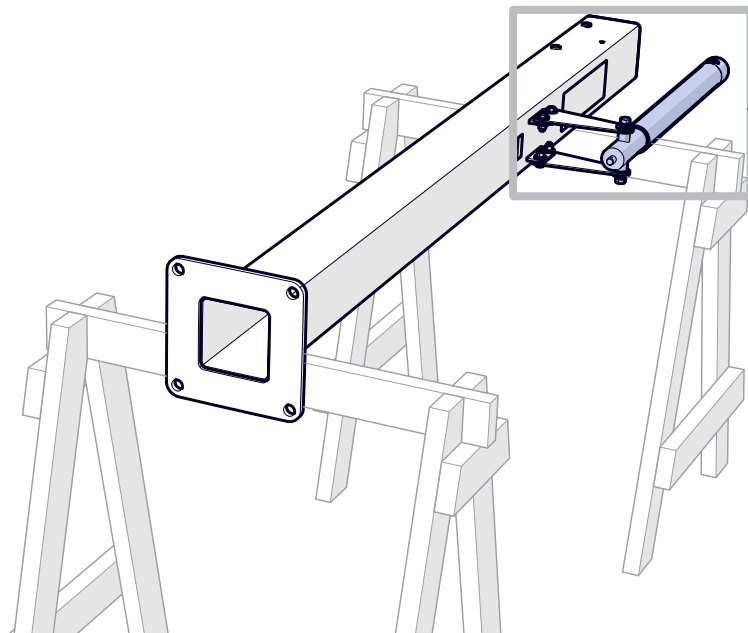

## TOOLS NEEDED

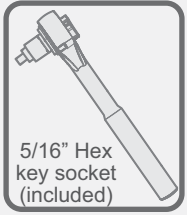

5/16" Hex  
key socket  
(included)

## HARDWARE NEEDED (ACTUAL SIZE)

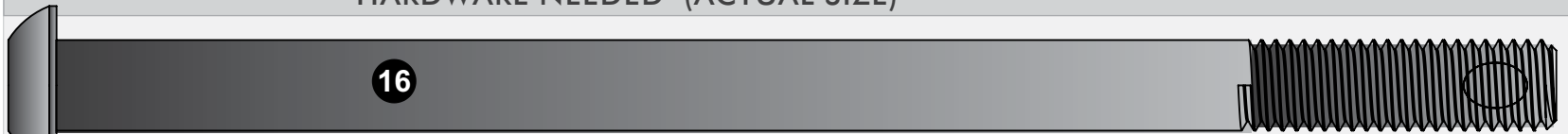

**16**  
BUTTON HEAD CAP SCREW 1/2"-13 X 8 1/4"  
1B-7130-00  
(QTY. 1)

4. Attach Upper Arm **3** to post as shown in **Detail A** & **Detail B**.  
Finger tighten bolt **16**.

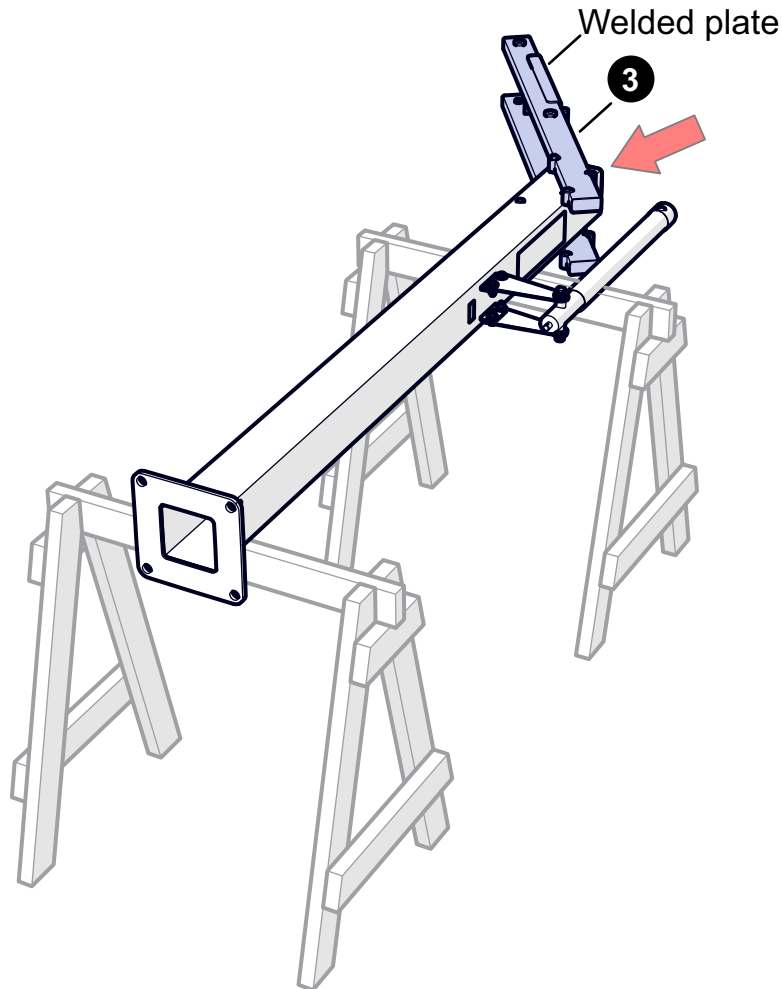

### DETAIL A

Slide upper pole at an **angle** as shown and then line up the holes.

Align **both** holes

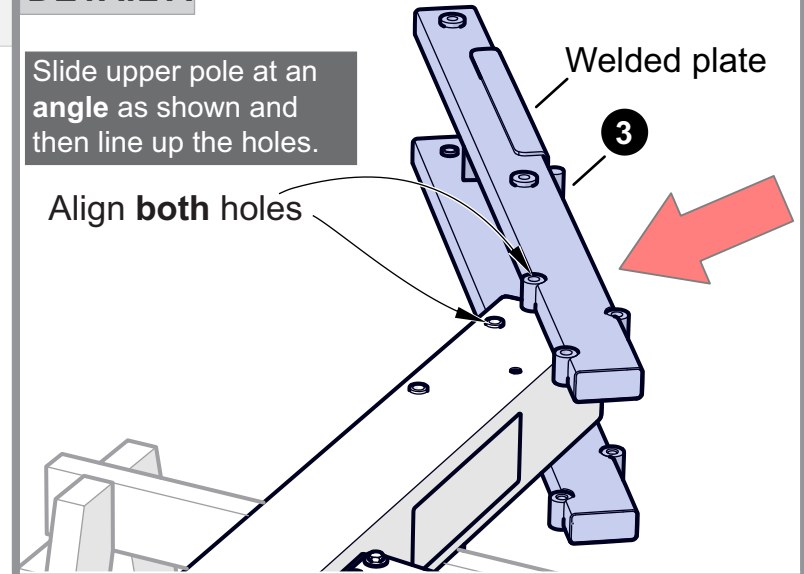

### DETAIL B

Only finger tighten Bolt **16** at this point, it will be tightened completely in Step 5.

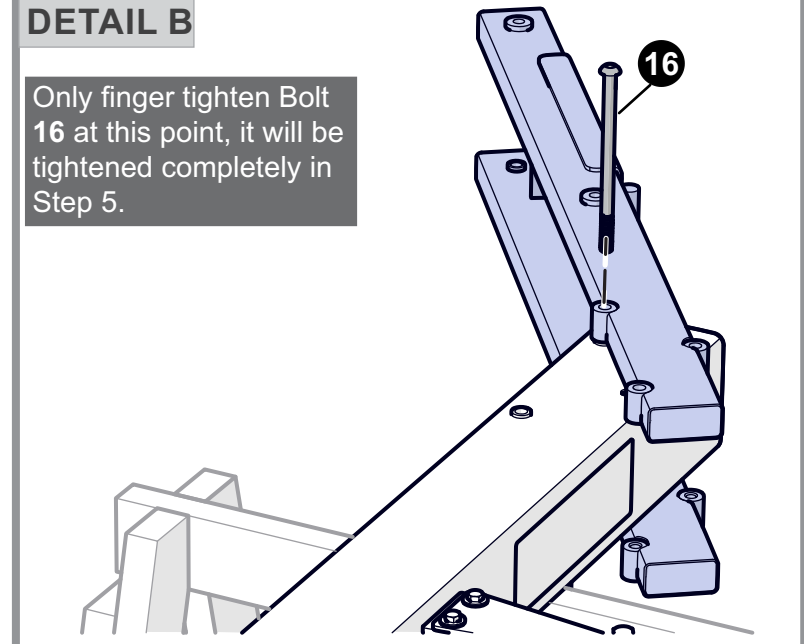

HARDWARE NEEDED (ACTUAL SIZE)

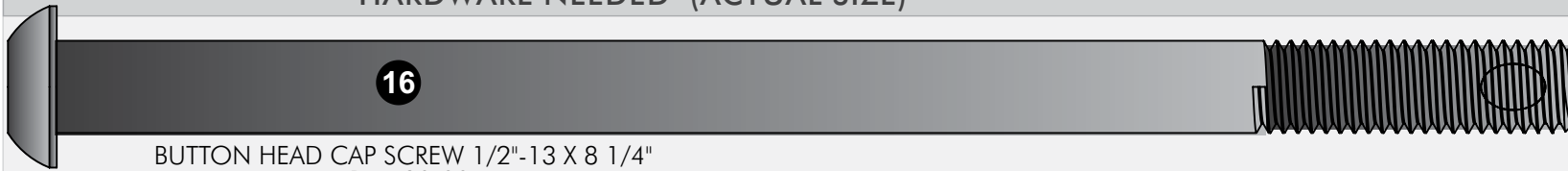

BUTTON HEAD CAP SCREW 1/2"-13 X 8 1/4"  
1B-7130-00  
(QTY. 2)

TOOLS NEEDED



5/16" Hex  
key socket  
(included)

5. Rotate and secure Upper Arm **3** to post as shown in **Detail A** & **Detail B**. Tighten all bolts **16** tight, including the bolt from **Step 4**.

DETAIL A

Rotate arm until the two bottom holes line up with pole holes.

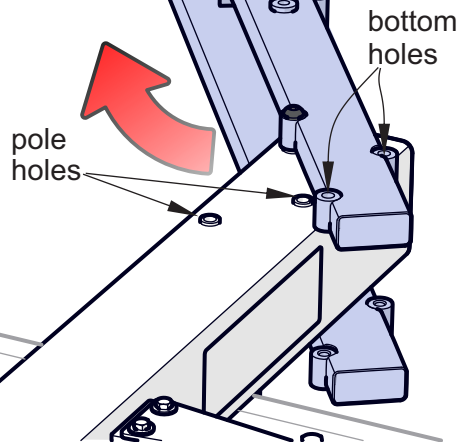

DETAIL B

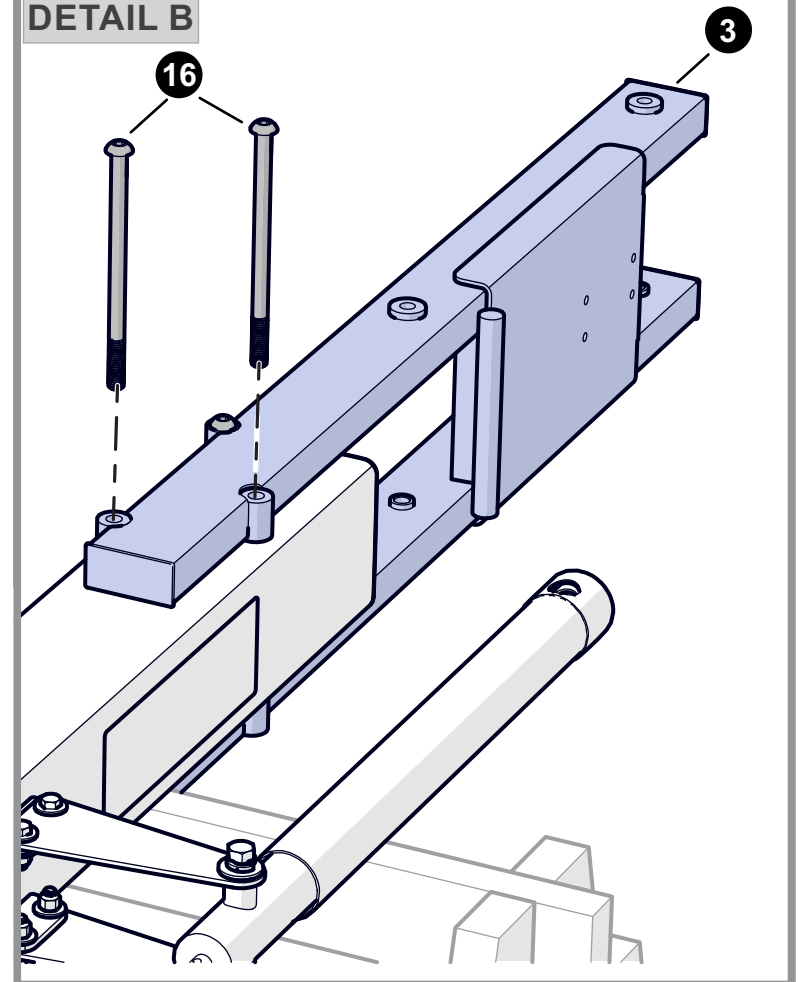

**HARDWARE NEEDED (ACTUAL SIZE)**

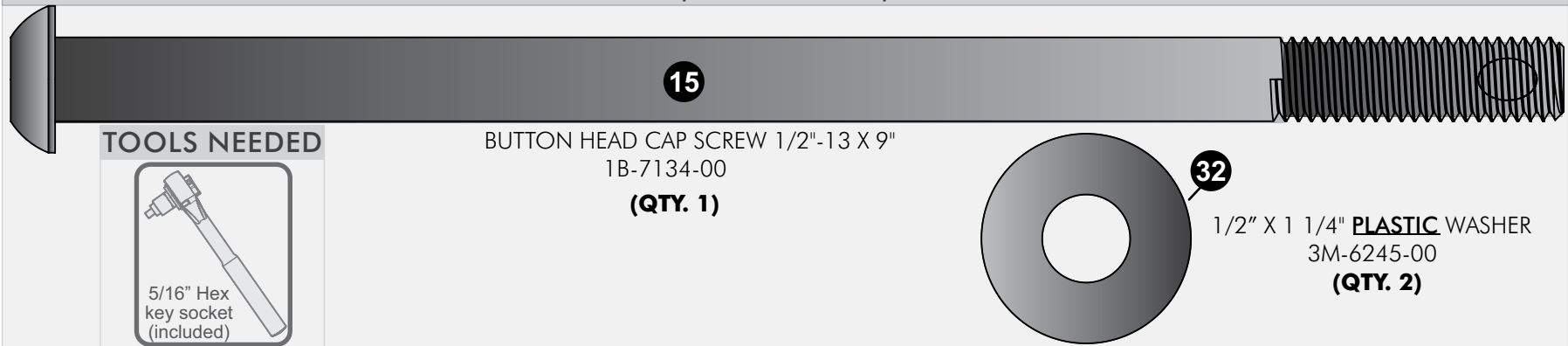

**TOOLS NEEDED**

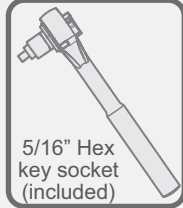

6. Attach Lower Board Arm **2** to Upper Pole **3** as shown in **Detail A**. Tighten bolt **16** tight.

Pay close attention to the location of the Plastic washers **32**. Washers should go in between Upper Pole **3** and Arm **2**.

**DETAIL A**  
 Back View

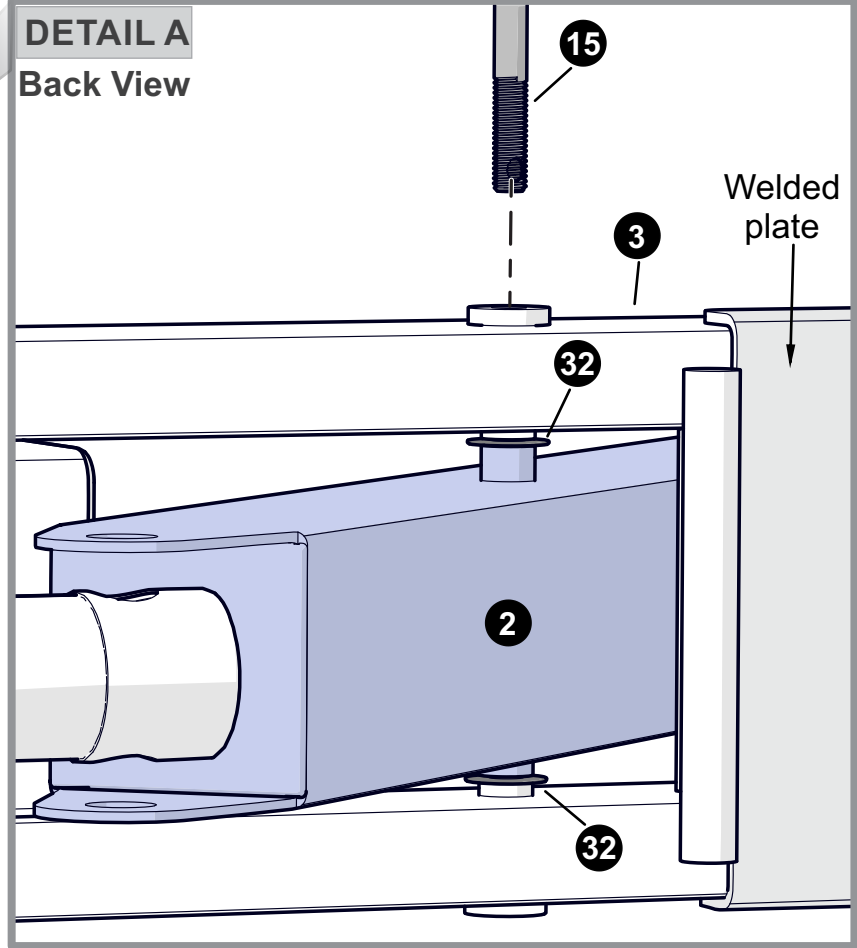

Make sure Goalrilla lettering is right side up as shown.

**NOTE**  
 PLASTIC WASHERS (#32) ADEQUATELY SPACE PAINTED PARTS AT ALL PIVOT POINTS. NEGLECTING THE USE OF THESE WASHERS WILL RESULT IN RUSTED PARTS.

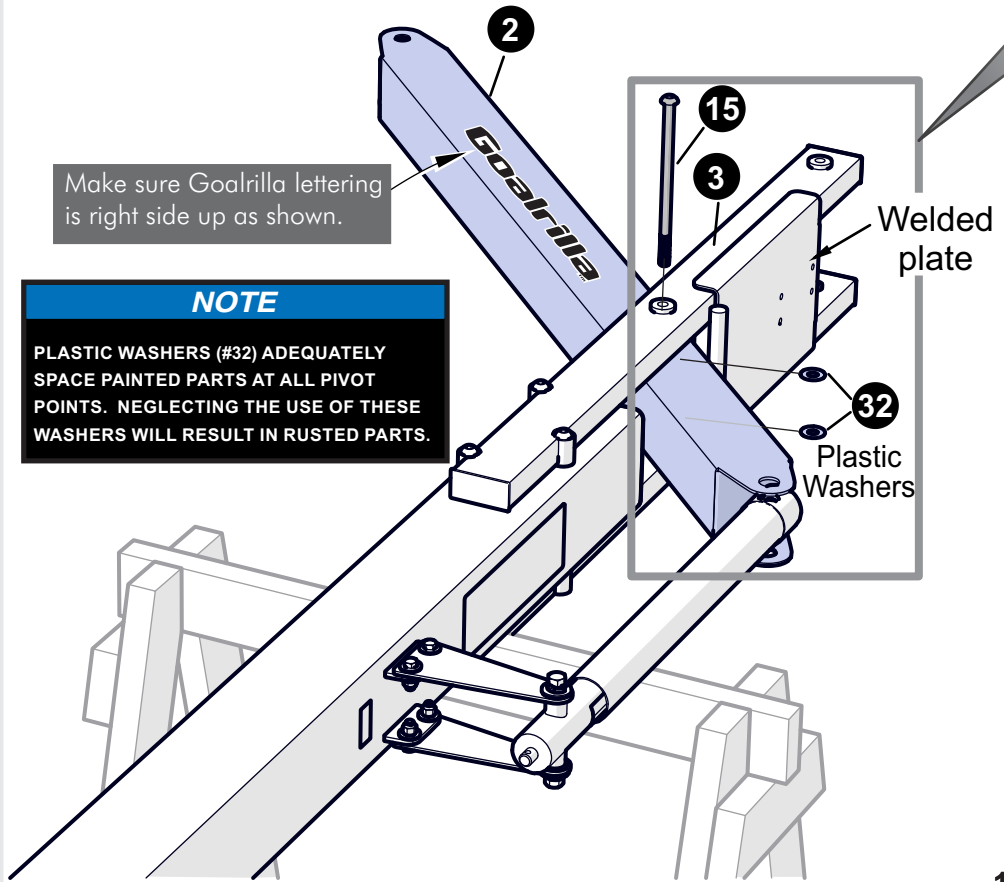

HARDWARE NEEDED (ACTUAL SIZE)

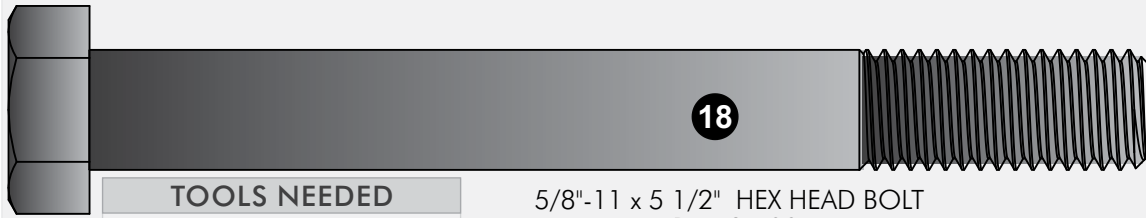

5/8"-11 x 5 1/2" HEX HEAD BOLT  
1B-7137-00

TOOLS NEEDED

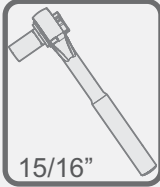

15/16"



15/16"

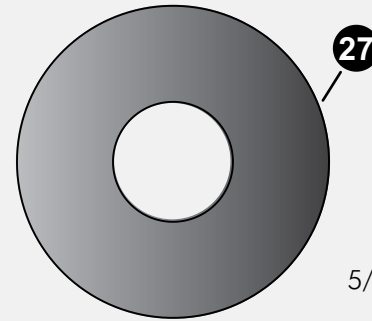

1-5/8" OD, 5/8" ID WASHER  
1B-7138-00  
(QTY. 2)

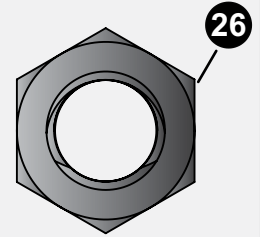

5/8-11 HEX NYLON LOCK NUT  
1B-7139-00  
(QTY. 1)

7. Secure Actuator to lower Arm **2** as shown in **Detail A** & **Detail B**. Tighten Bolt **18** & Nut **26** very tight.

Tighten hardware (**18** & **26**) very tight! Pole Ears may bend in slightly, this is expected.

DETAIL A

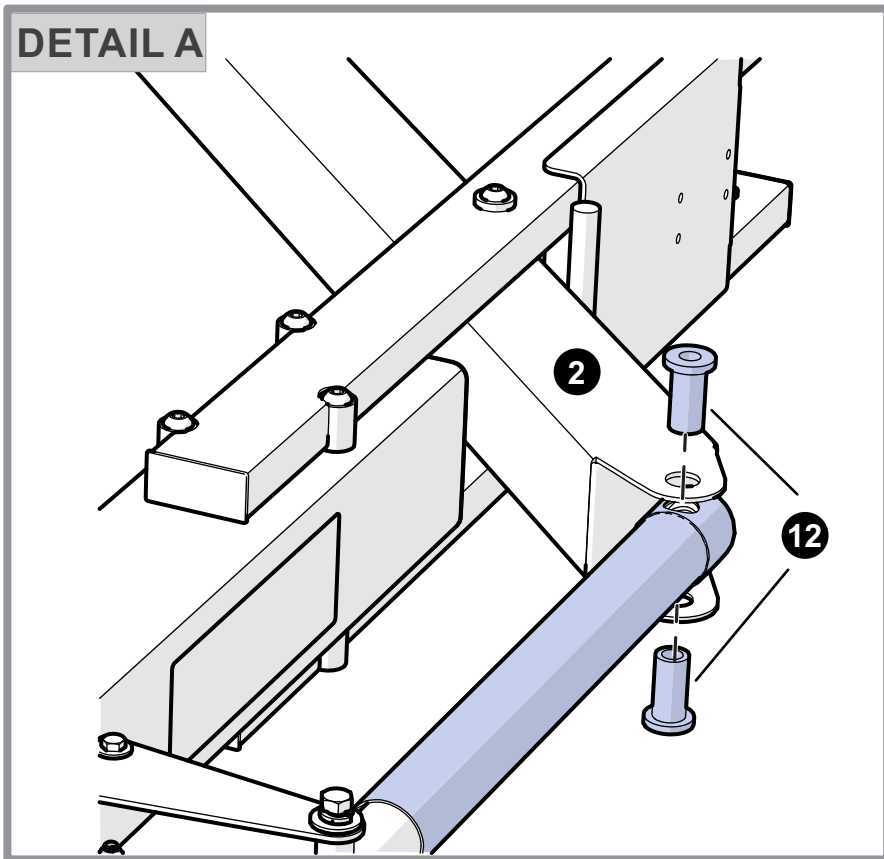

DETAIL B

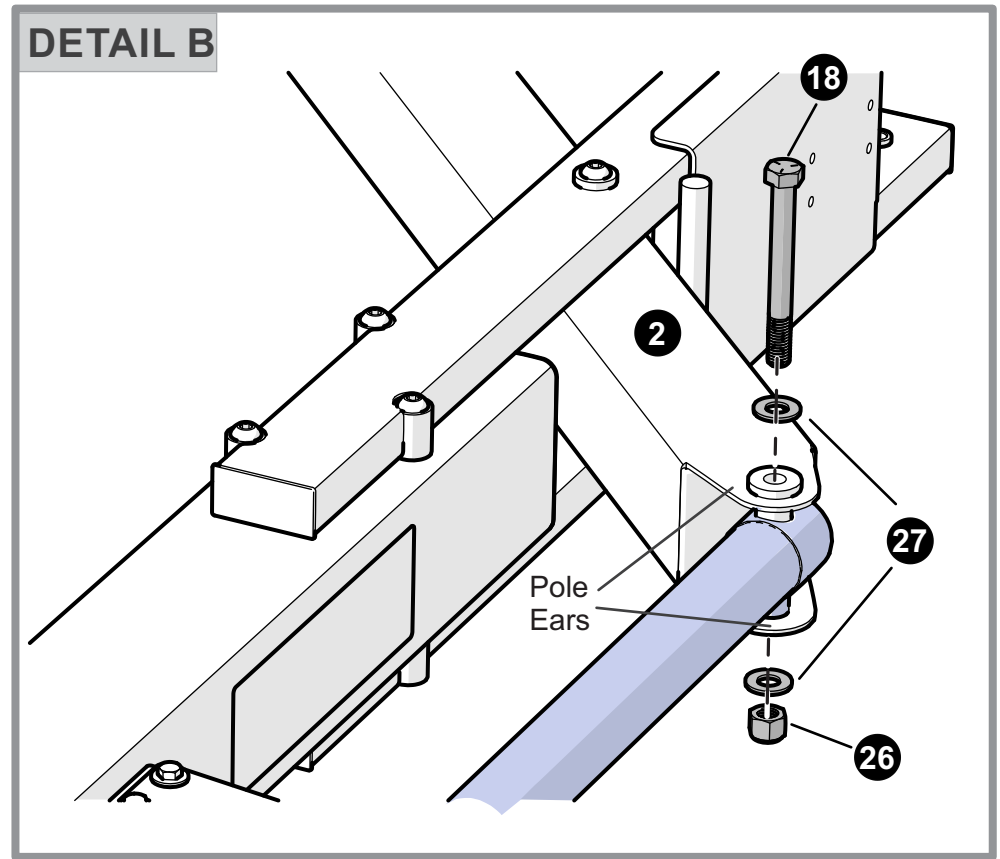



**HARDWARE NEEDED (ACTUAL SIZE)**

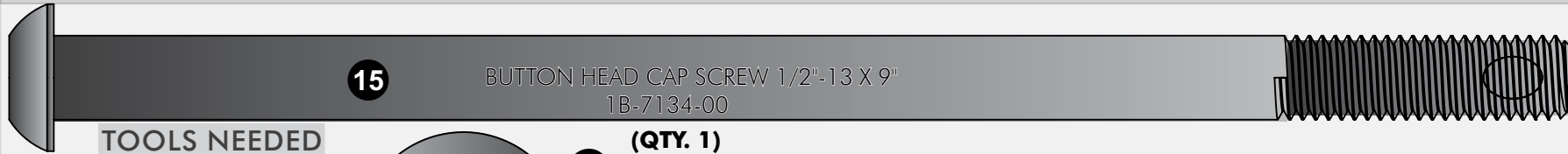

**15**

BUTTON HEAD CAP SCREW 1/2"-13 X 9"  
1B-7134-00

**TOOLS NEEDED**

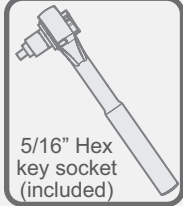

5/16" Hex  
key socket  
(included)

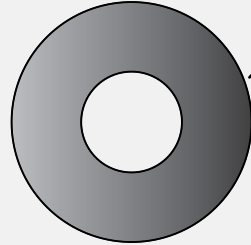

**32**

1/2" X 1 1/4" **PLASTIC** WASHER  
3M-6245-00  
**(QTY. 2)**

8. Attach Upper Arms **5R** (Right) & **5L** (Left) as shown in **Detail A**. Tighten Bolt **15**, but **DO NOT** over-tighten.

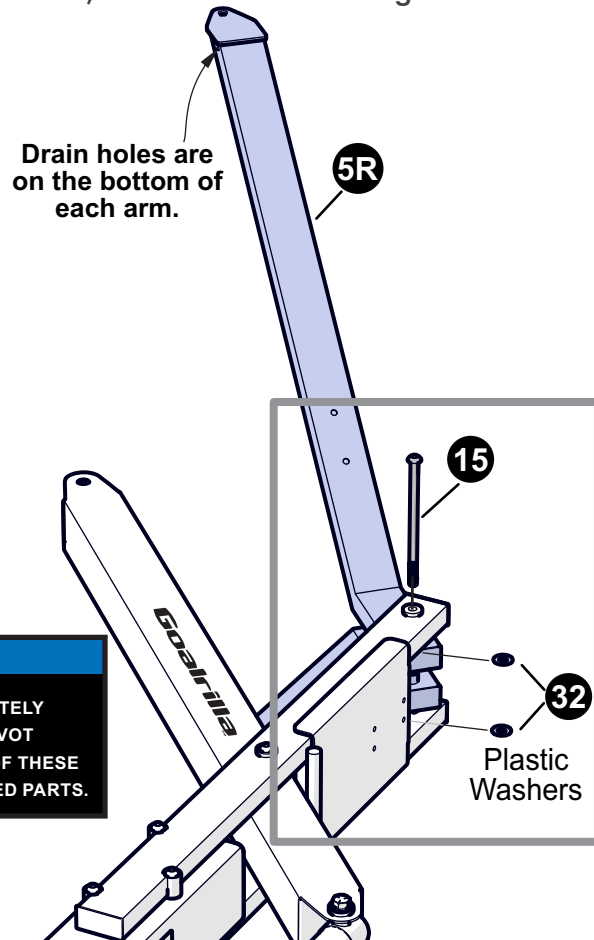

Drain holes are  
on the bottom of  
each arm.

**5R**

**15**

**32**

Plastic  
Washers

**NOTE**

PLASTIC WASHERS (#32) ADEQUATELY  
SPACE PAINTED PARTS AT ALL PIVOT  
POINTS. NEGLECTING THE USE OF THESE  
WASHERS WILL RESULT IN RUSTED PARTS.

Pay close attention to the location of the Plastic washers **32**. Washers should go in between Upper Pole **3** and Upper Board Arms **5L** & **5R**.

**DETAIL A**  
**Back View**

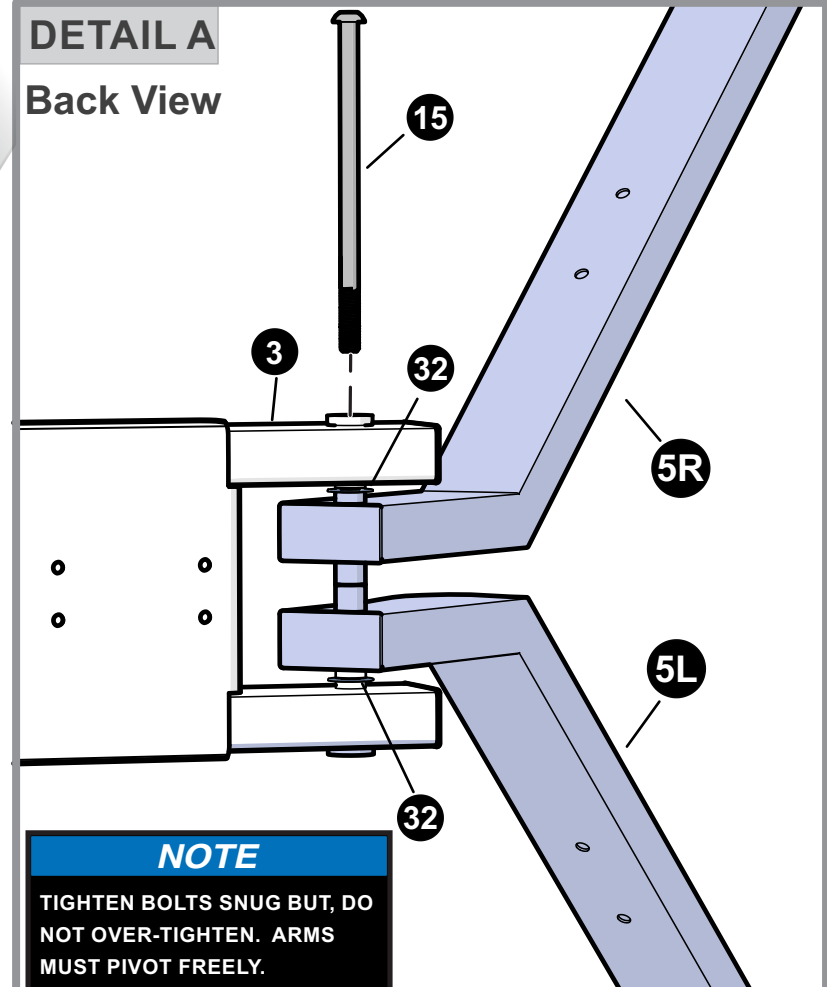

**15**

**3**

**32**

**5R**

**5L**

**32**

**NOTE**

TIGHTEN BOLTS SNUG BUT, DO  
NOT OVER-TIGHTEN. ARMS  
MUST PIVOT FREELY.

**HARDWARE NEEDED (ACTUAL SIZE)**



3/8-16 X 2 9/16" HEX BOLT  
1B-7131-00  
**(QTY. 4)**

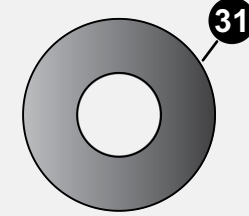

3/8 FLAT WASHER  
2B-6237-10  
**(QTY. 8)**

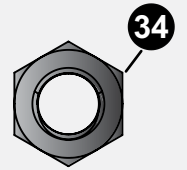

3/8-16 LOCKNUT  
2B-6238-10  
**(QTY. 4)**

9. Insert hardware as shown but do not tighten yet.

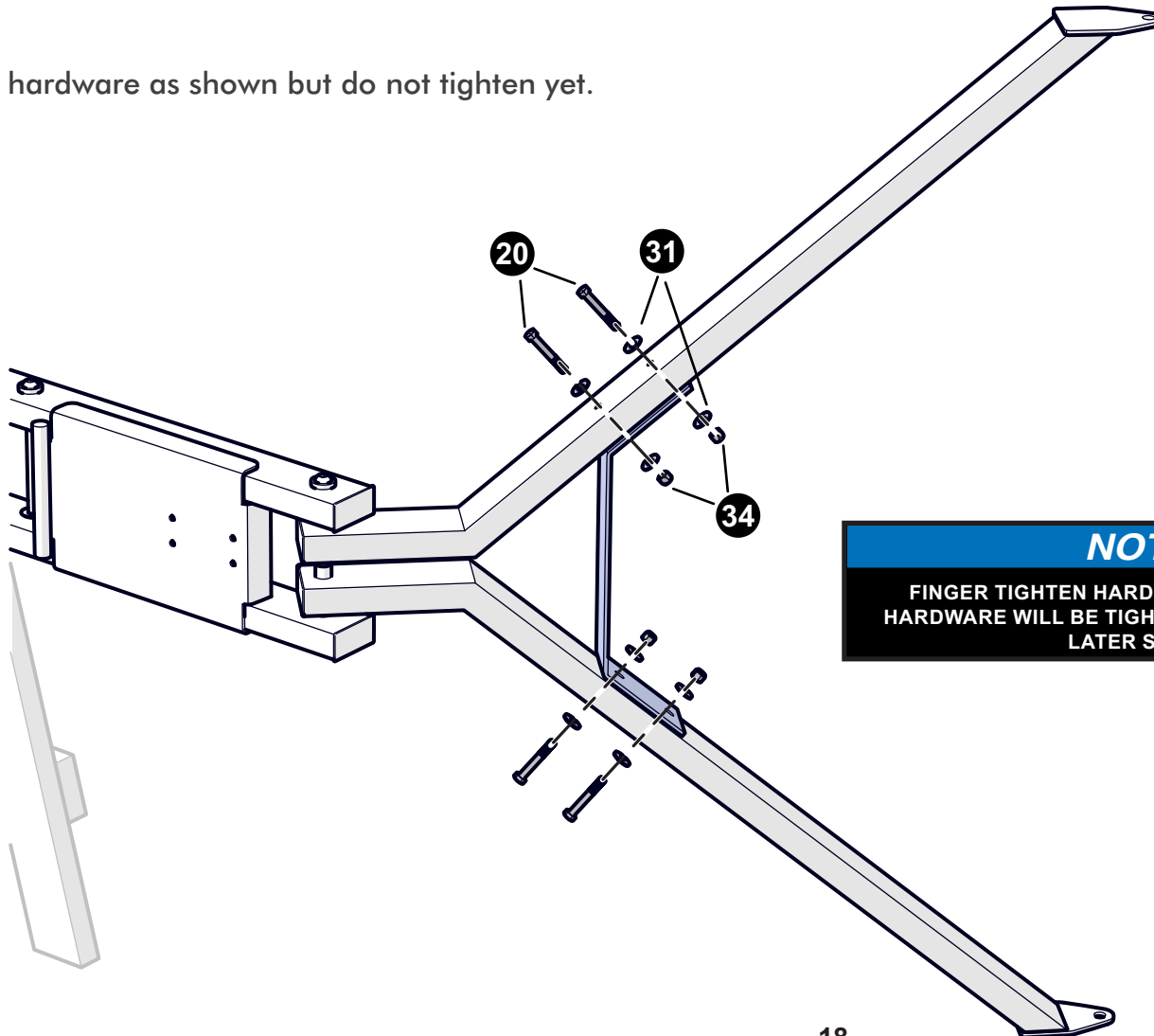

**NOTE**

FINGER TIGHTEN HARDWARE AT THIS POINT.  
HARDWARE WILL BE TIGHTENED COMPLETELY IN  
LATER STEPS.

## HARDWARE NEEDED (ACTUAL SIZE)

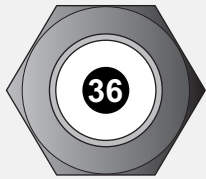

5/8"-11 HEX NUT, BLACK  
2B-6097-02  
**(QTY. 4)**

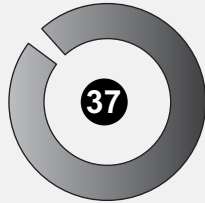

5/8" SPLIT LOCK  
WASHER, BLACK  
2B-6099-02  
**(QTY. 4)**

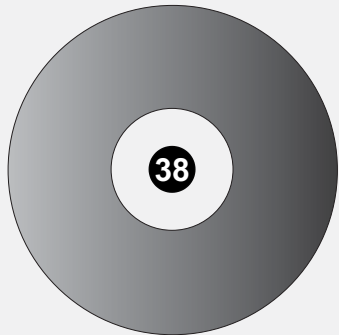

5/8" FLAT WASHER, BLACK  
2B-6098-03  
**(QTY. 8)**

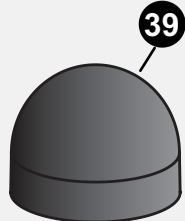

5/8" THREAD  
PROTECTOR  
PLASTIC CAP  
3M-9040-00  
**(QTY. 4)**

**\*Hardware located in Anchor kit box**

10. Lift post onto anchor system and secure with hardware as shown. Tighten Fasteners finger tight, leave loose enough to level pole. Place a level on pole and adjust bottom nuts **36** until pole is level (left to right and front to back). Tighten top four hex nuts **36** tight.

11. Push on Thread Protector Cap **39** until it is securely in place. Cap may be tight, push hard but **DO NOT** hit with a hammer! See **Detail A**.

## TOOLS NEEDED

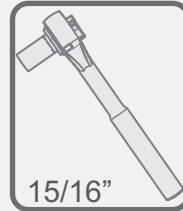

15/16"

OR



15/16"

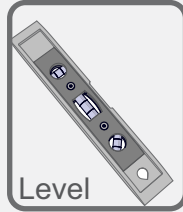

Level



**PLACING THE POST ON THE ANCHOR SYSTEM  
REQUIRES AT LEAST FOUR CAPABLE ADULTS.  
POLE WILL WANT TO LEAN WHILE ATTEMPTING TO  
STAND IT UP ON ANCHOR BOLTS.**

## NOTE

**DO NOT REMOVE BOTTOM NUTS #36 THAT  
YOU INSTALLED IN STEP 2 (PAGE 9).**

Let concrete cure for a  
**MINIMUM** of 72 hours  
before installing pole.

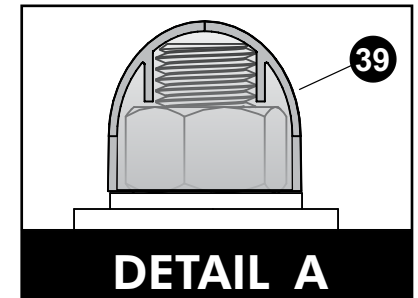
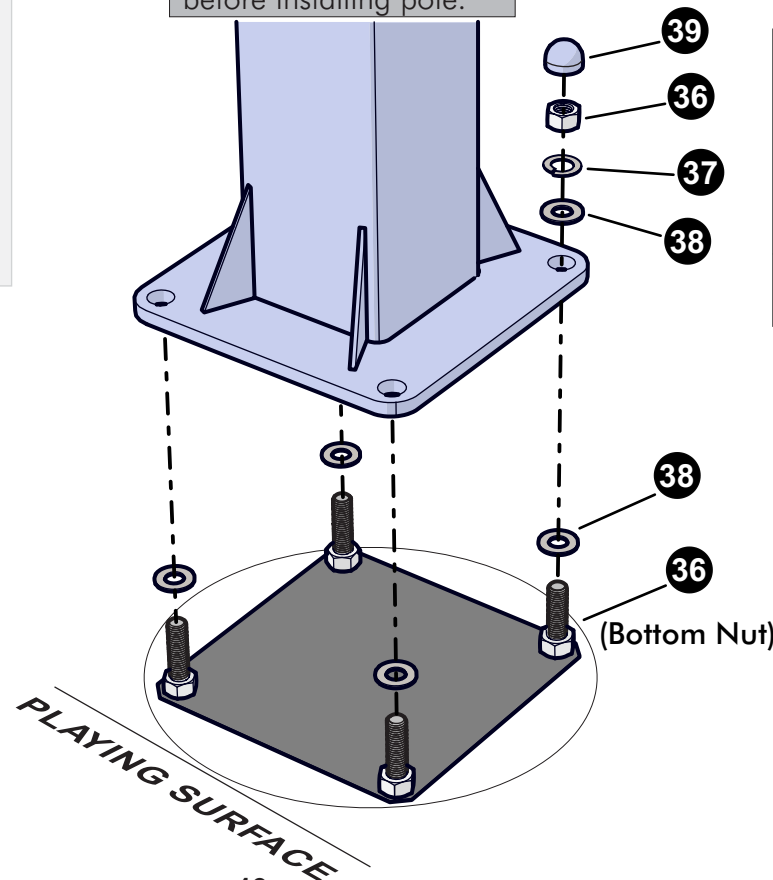

## NOTE:

If basketball system needs to be moved, **do not** try to salvage caps. Caps **39** will be tight, please remove with pliers and discard. New caps will come in new anchor system.

## NOTE:

If **39** caps are missing for any reason please call customer service.

## NOTE:

Bottom nuts **36** can be used for leveling system. See **Step 10**.

12. Attach handle as shown and lower unit until Lower Arm 2 rests on **Safety Stop**.

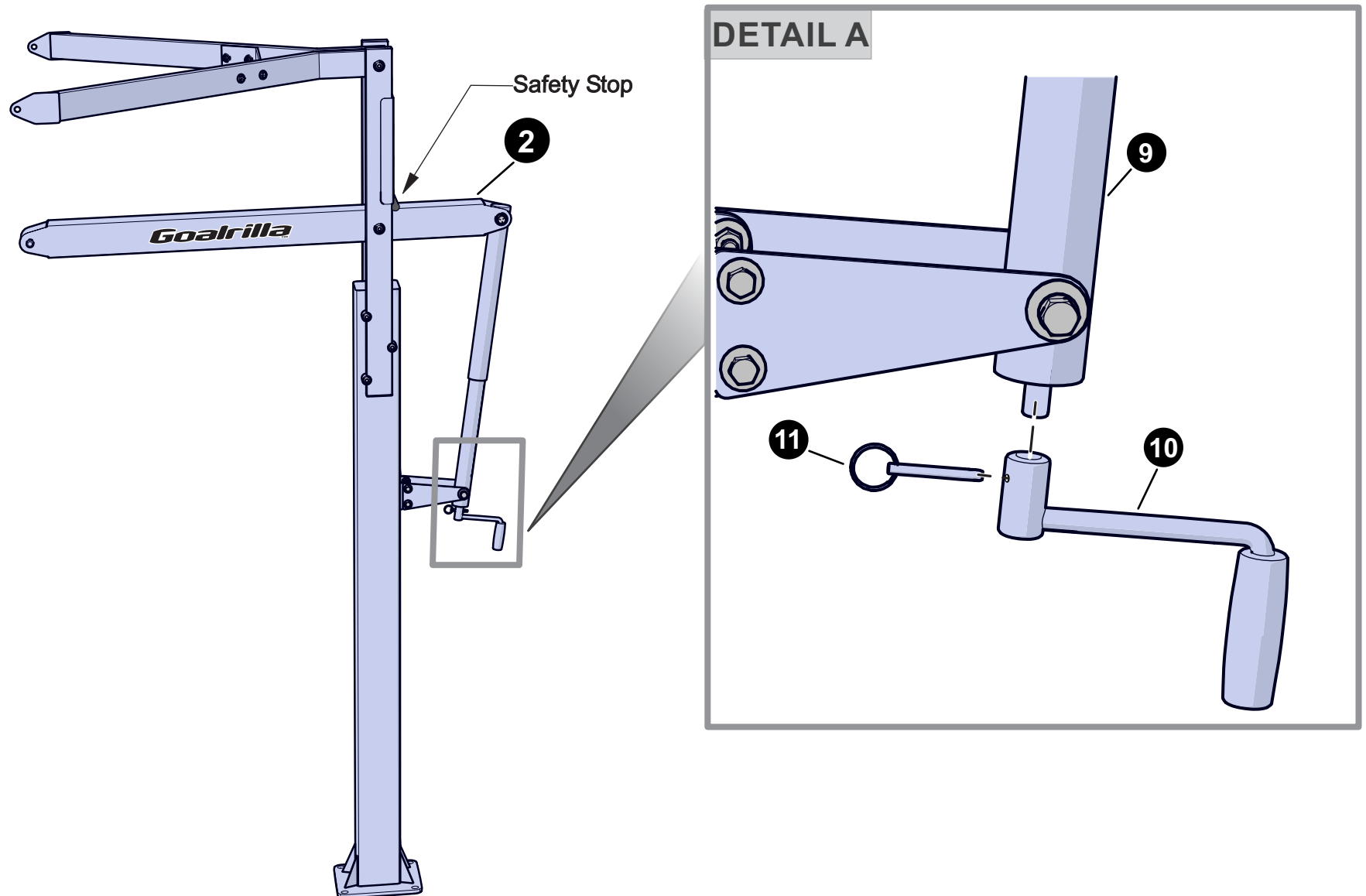

**HARDWARE NEEDED (ACTUAL SIZE)**

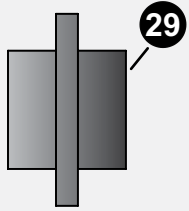

TWO WAY STEP BUSHING  
7B-6439-00  
**(QTY. 2)**

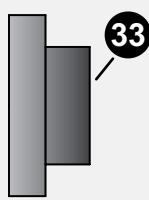

STEP BUSHING  
7B-6391-01  
**(QTY. 2)**

**NOTE**  
IF THE STEP BUSHINGS (#33) AND BOARD BUSHINGS (#29) ARE NOT ALREADY PRE-INSTALLED INSERT AS SHOWN IN DETAIL A & DETAIL B.

13. If not already installed, insert bushings **29** and **33** as shown in **Detail A** & **Detail B**.

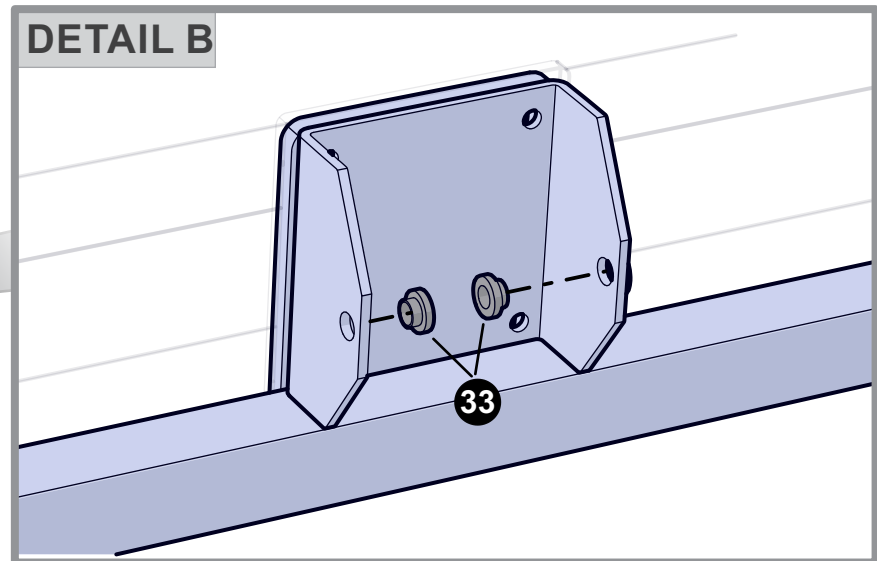
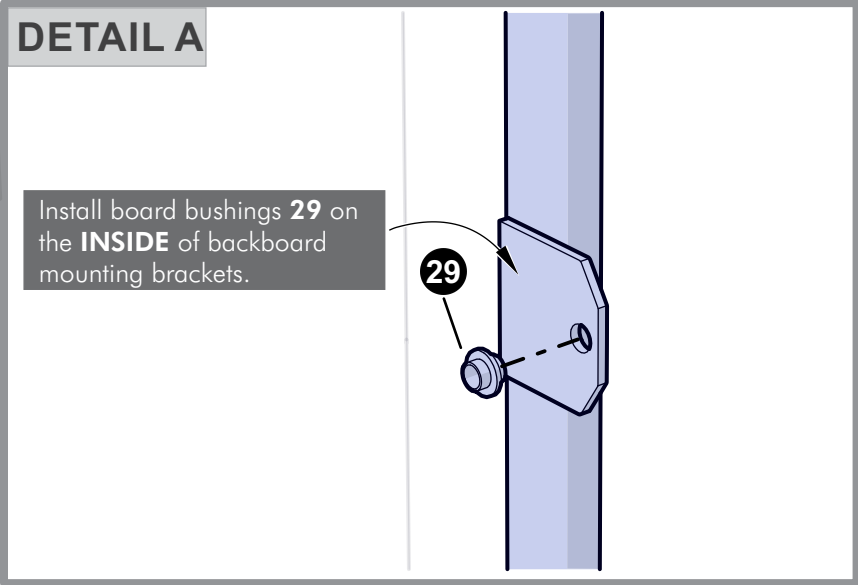
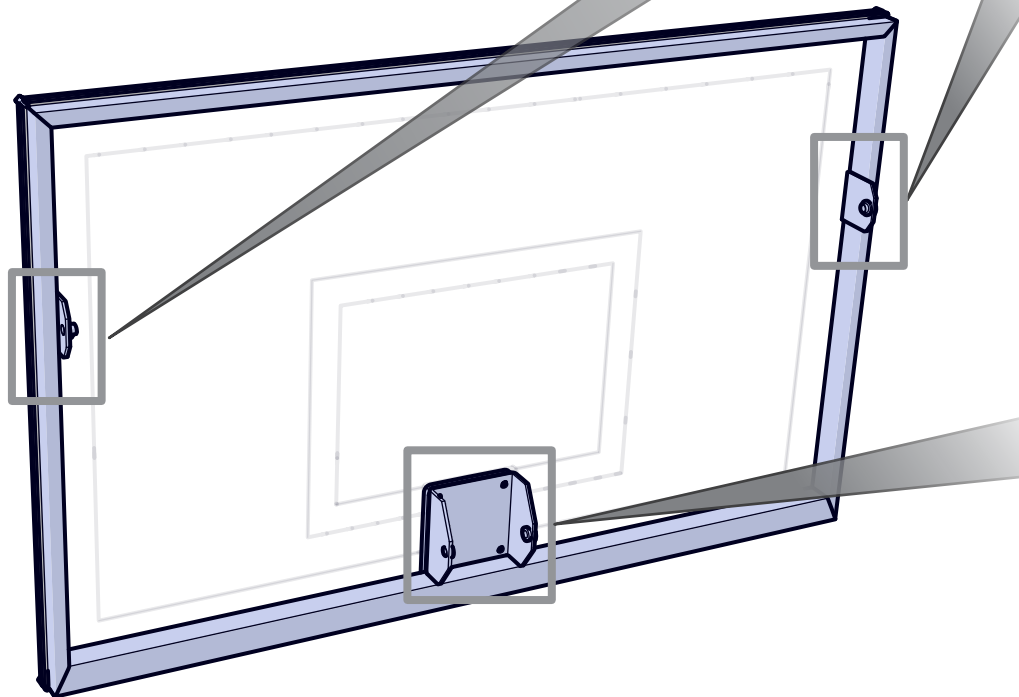

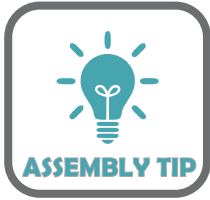

Before proceeding to the next step have the hardware and tools ready along at least 4 other capable people, read the next page completely and understand it before beginning the next step.

### TOOLS NEEDED



3/4"

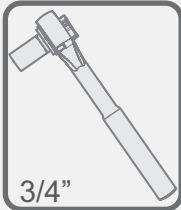

3/4"



### HARDWARE NEEDED (ACTUAL SIZE)

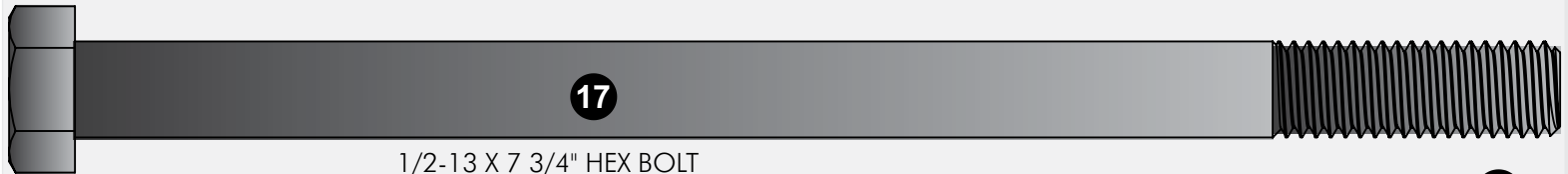

1/2-13 X 7 3/4" HEX BOLT  
1B-7133-00  
**(QTY. 1)**

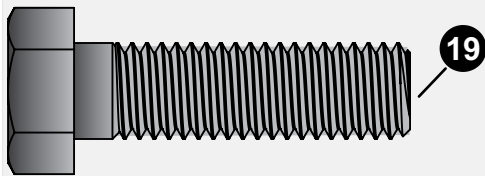

1/2-13 X 1 3/4" HEX BOLT  
1B-6944-10  
**(QTY. 2)**

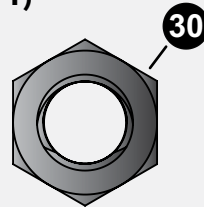

1/2-13 LOCKNUT  
2B-6095-10  
**(QTY. 3)**

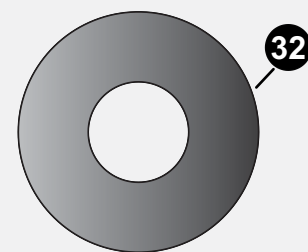

1/2 X 1 1/4" PLASTIC WASHER  
3M-6245-00  
**(QTY. 6)**

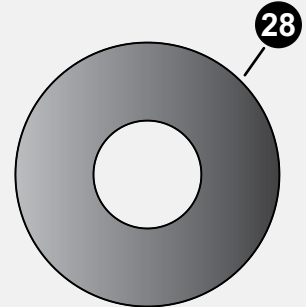

1/2" FLAT WASHER  
2B-6093-10  
**(QTY. 6)**

**! CAUTION !**

ATTACHING BACKBOARD TO BOARD ARMS REQUIRES AT LEAST FIVE CAPABLE ADULTS.

**! CAUTION !**

HANDLE BACKBOARD WITH CARE, IT IS A GLASS PRODUCT ALWAYS WEAR SAFETY GLASSES AND GLOVES WHEN HANDLING GLASS.

14. With at least **four** capable adults, raise the backboard assembly up and have the **fifth** person attach lower board arm **2** to **rim support** as shown in **Detail B**.
15. Attach upper **Board Arms** to the inside of **upper mounting brackets** as shown in **Detail A**. Tighten hardware from **Step 14 & 15** at this time but **DO NOT** over-tighten, these are pivot points.

**NOTE**

DO NOT OVER TIGHTEN THESE BOLTS. THIS IS A PIVOT POINT, SNUG IS TIGHT ENOUGH.

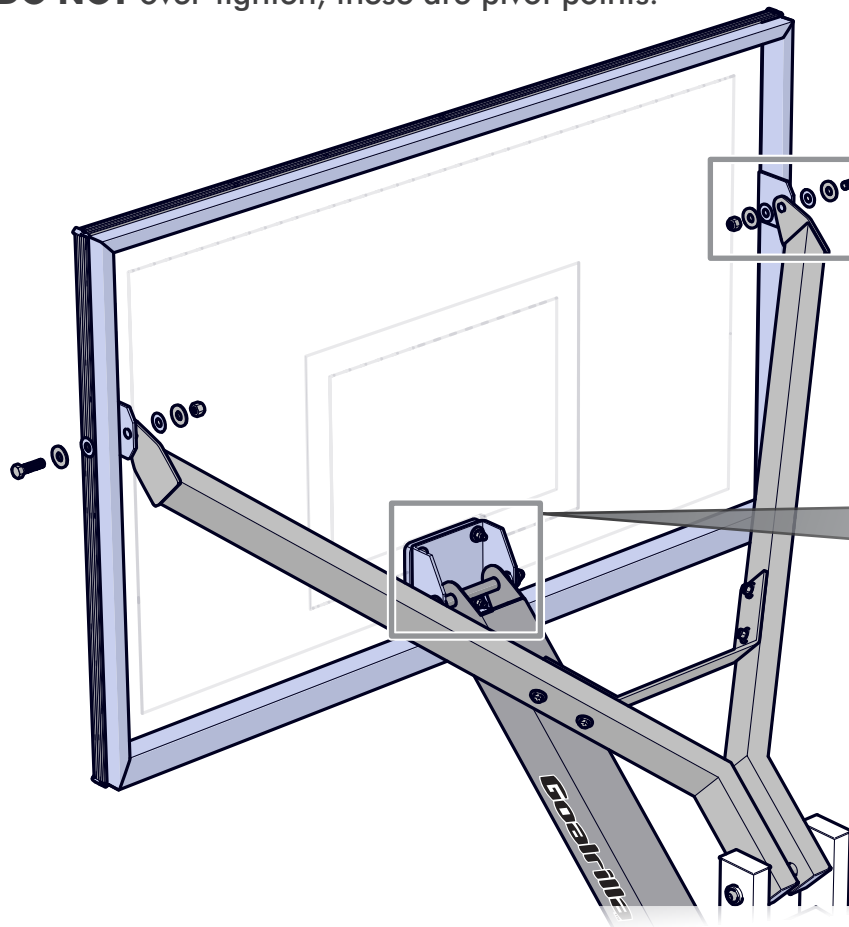

DETAIL A

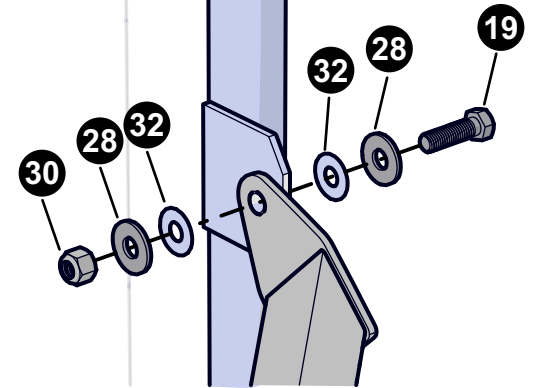

DETAIL B

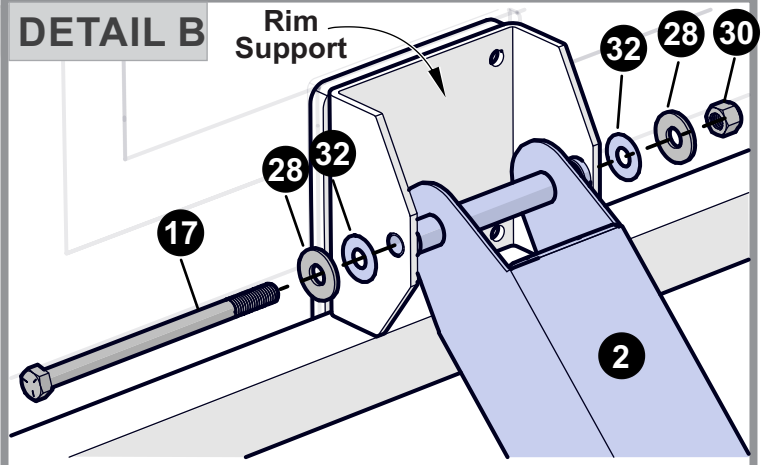

## TOOLS NEEDED

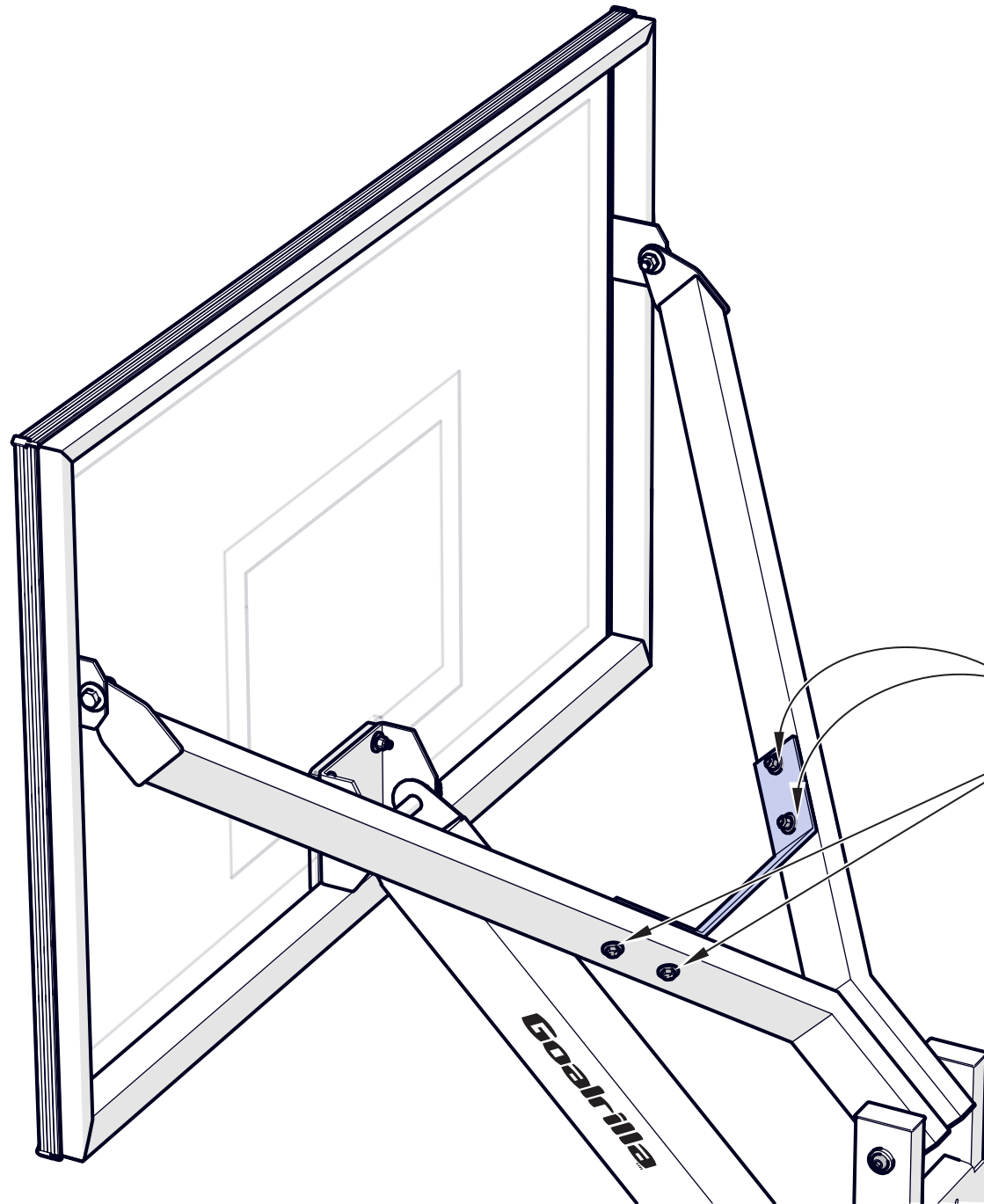
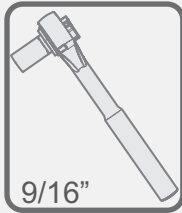

### NOTE

AT THIS TIME TIGHTEN THIS  
HARDWARE BUT, DO NOT  
OVER-TIGHTEN YOU MAY  
CRUSH THE TUBES!



## HARDWARE NEEDED (ACTUAL SIZE)

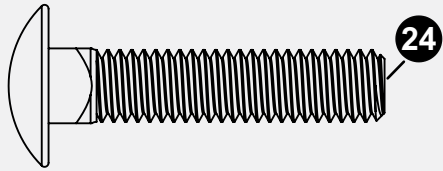

3/8-16 X 1 3/4" CARRIAGE BOLT  
1B-6782-10  
**(QTY. 4)**

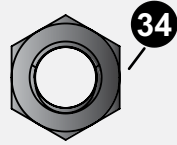

3/8-16 LOCKNUT  
2B-6238-10  
**(QTY. 4)**

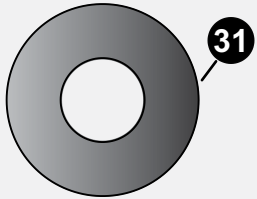

3/8 FLAT WASHER  
2B-6237-10  
**(QTY. 4)**

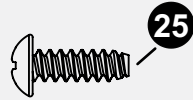

#8 X 1/2" THREAD FORMING SCREW  
1B-6238-01  
**(QTY. 4)**

## TOOLS NEEDED

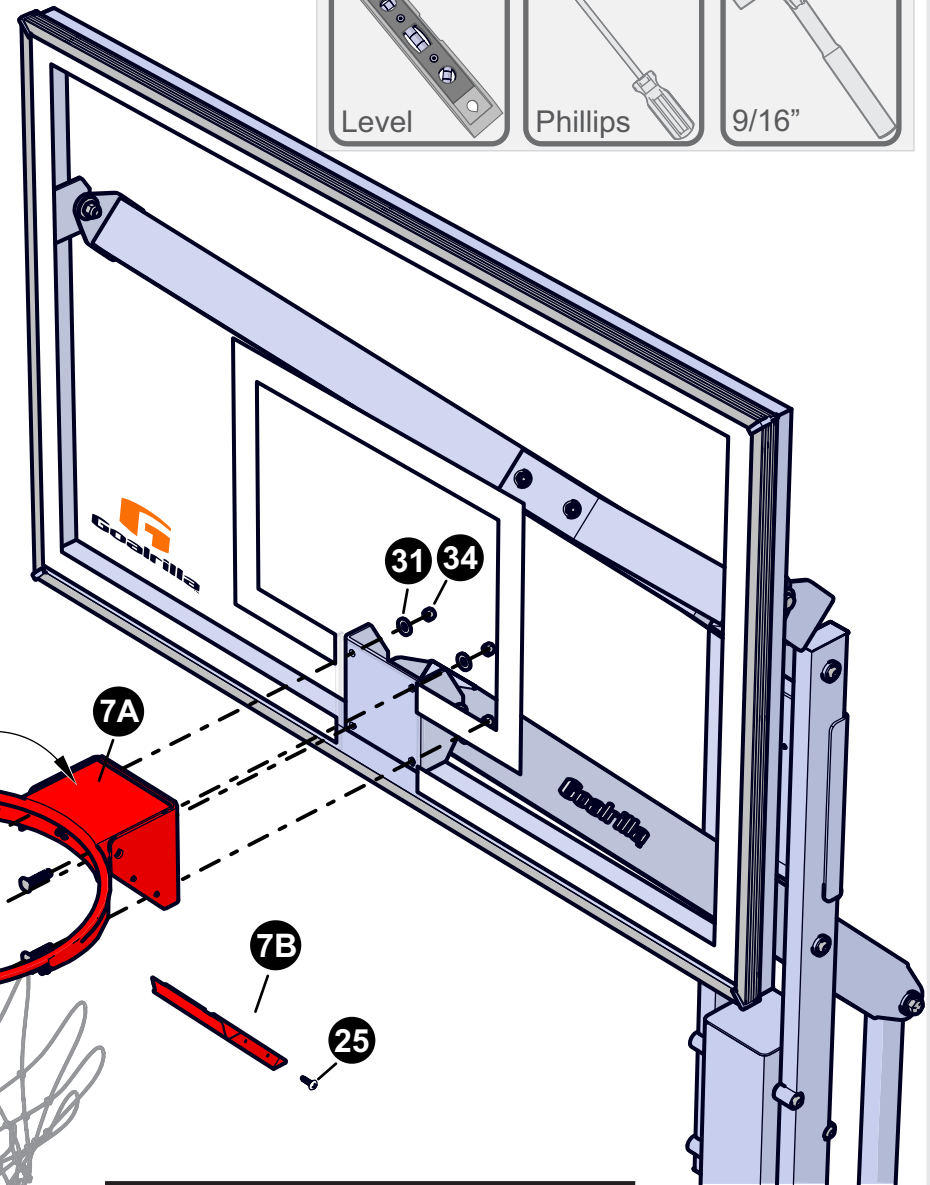
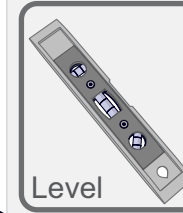

**INSTALL RIM EXACTLY AS SHOWN. FAILURE TO DO SO COULD DAMAGE GLASS.**

16. Mount Goal Assembly **7A** to backboard as shown. Tighten nuts **34** but leave loose enough to level Rim.
17. Place Level across Goal Assembly **7A** and adjust until it is level. Finish tightening nuts **34** until Rim is secure.
18. Attach Rim Cover Plate **7B** with four screws **25** and then Net **8**.



**NEVER USE RIM WITH COVERPLATE REMOVED!**

### TOOLS NEEDED

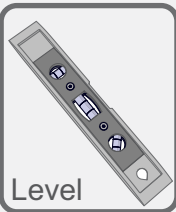

Level

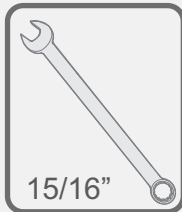

15/16"

### NOTE:

Two adults are recommended for this step, one to level and one to adjust the bottom #36 nuts.

19. If further leveling is required loosen top **36** nuts but do not loosen past the top of **40** "J" Bolt. **DO NOT REMOVE NUTS 36.** Place a level on pole and adjust bottom nuts **36** with a 15/16" open end wrench until pole is level. Tighten top **36** hex nuts. See **Detail A**.

### DETAIL A

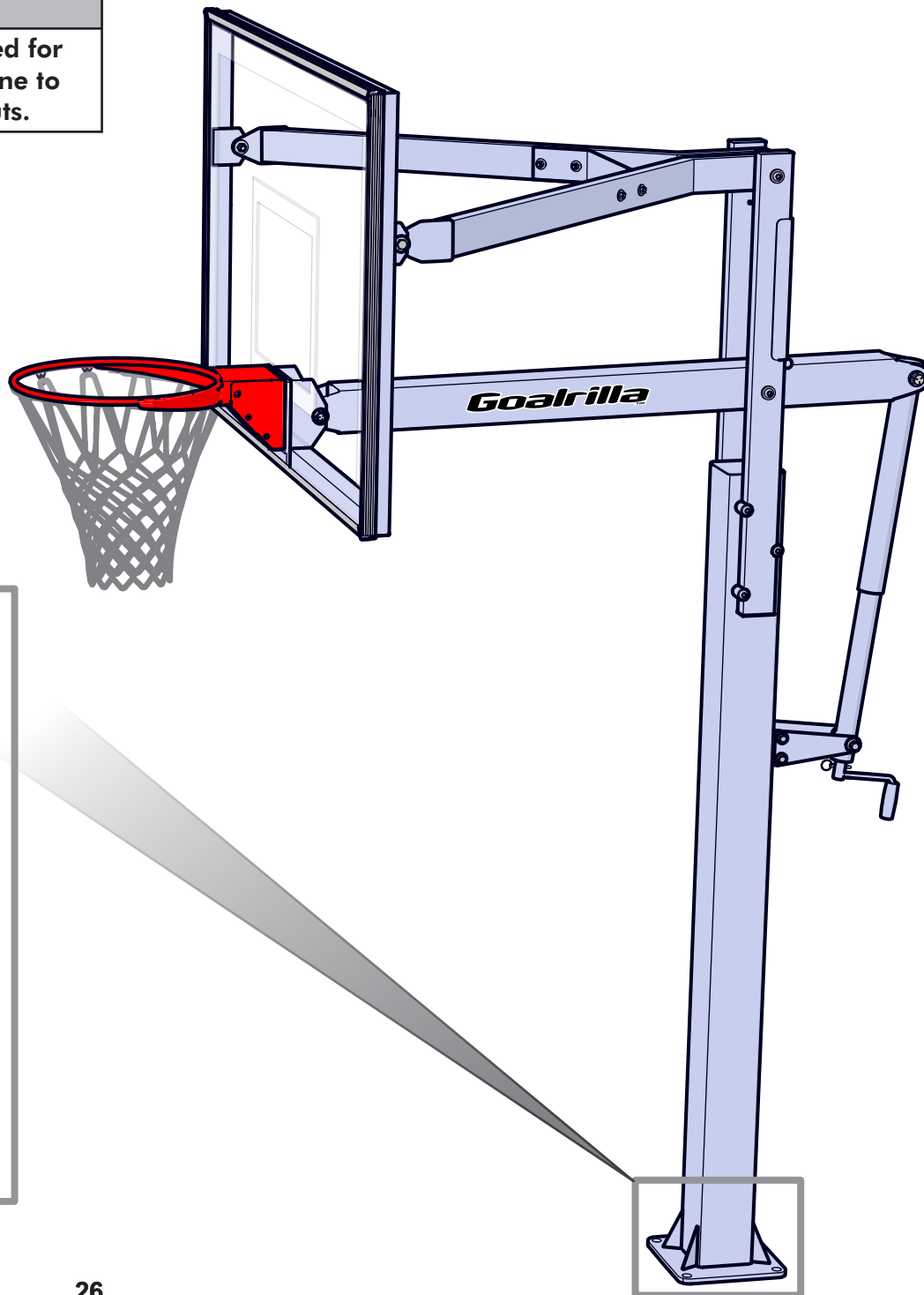
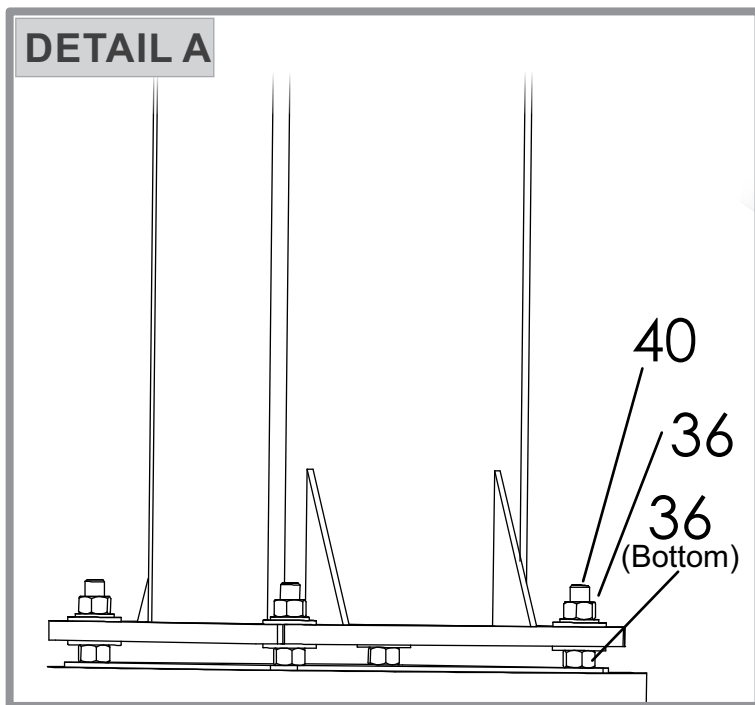

20. Raise Backboard to 10 FT. regulation playing height. Measure from top of rim straight down to the playing surface. Using tape - mark the **side** of the steel actuator **9** just under the plastic actuator sleeve **45** at this 10 ft rim height. See **Detail A**.
21. Lower backboard all the way down. Do not force actuator once backboard is in it's lowest position. See **Detail B**.
22. **Do not** remove adhesive backing from height decal **14** yet. Carefully place height decal on backside of steel actuator and line up the 10 ft mark on the tape with the 10 ft mark on the height decal. Decal should fit correctly onto the backside of the steel actuator. ( If not, simply trim to fit the top of the actuator decal). See **Figure 1**.
23. Remove the adhesive backing from the Height Decal **14**. Next, carefully align and stick decal to backside of steel actuator **9** starting at the **10 ft mark first**. Be sure to keep the height decal straight and rub out all air bubbles. See **Figure 1**.

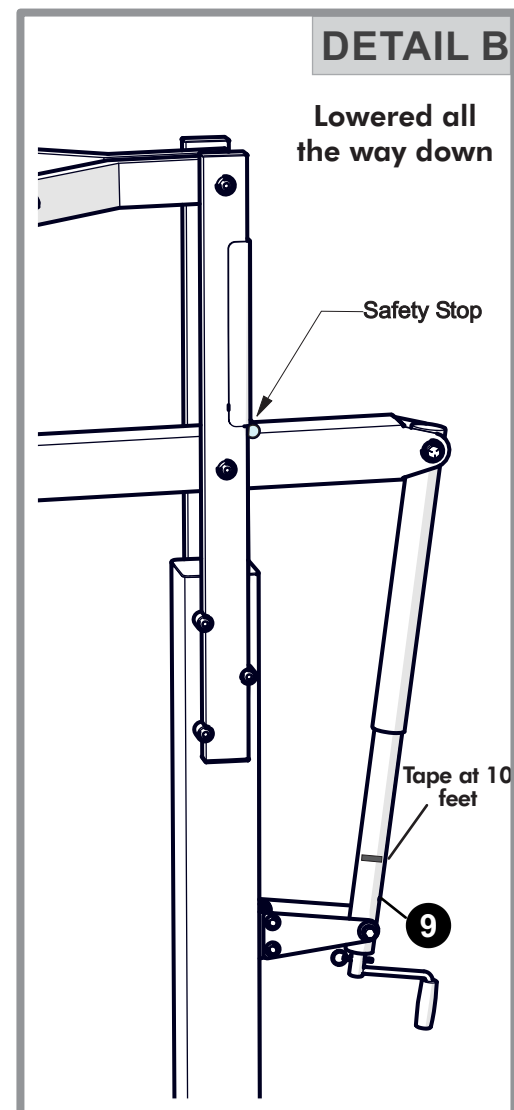
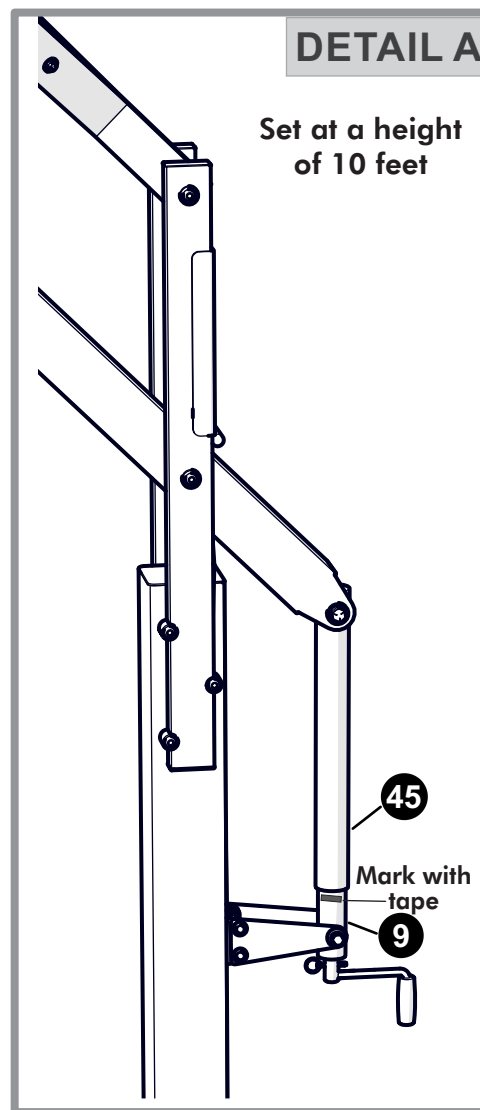
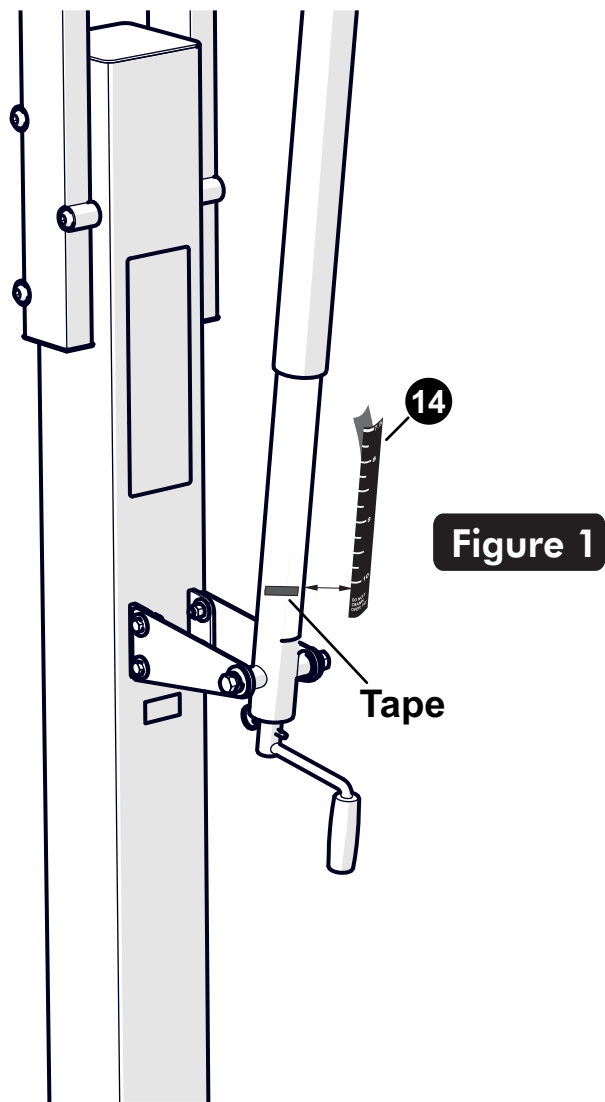

## CARE AND MAINTENANCE

### BACKBOARD CARE AND MAINTENANCE

#### Items needed to clean backboard:

- 100% cotton soft cloth, (only)
- Glass cleaner

Clean backboard using only a **100% Cotton** soft cloth and glass cleaner. Clean glass as you would clean household windows. Strong cleansers will damage backboard and void warranty.

### RIM

**Only hang from the rim briefly to regain balance or avoid injuring others. Release the rim as soon as safely possible.** Rims are not warranted for any defects other than workmanship. Torn back plates, damaged springs, bent rings, damaged eye bolts, and torn or distorted rim supports result from hanging on the rim and are not warranted.

The goal should not be cranked over 10'. Adjustments of the goal should be done under adult supervision.

When attempting slam dunk activity you should always wear a mouth guard to avoid dental injury.

### MAINTENANCE

To ensure ease of operation, lubricate all pivot points at least every 6 months or as needed with a good lubricant such as WD-40.

### RUST

Inspect your pole periodically, if rust should appear, remove loose paint, sand lightly, primer and paint with exterior flat matte finish enamel paint.

## LIMITED LIFETIME WARRANTY

This consumer warranty extends to the original consumer purchase of any Escalade® Sports Product (hereinafter referred to as the "Product").

**WARRANTY COVERAGE:** Escalade® Sports warrants to the original Consumer Purchaser that any Product of its manufacture is free from defects in material and workmanship. THIS WARRANTY IS VOID IF THE PRODUCT HAS BEEN DAMAGED BY ACCIDENT, UNREASONABLE USE, NEGLIGENCE, IMPROPER SERVICE, FAILURE TO FOLLOW INSTRUCTIONS PROVIDED WITH THE PRODUCT OR OTHER CAUSES NOT ARISING OUT OF DEFECTS IN MATERIAL OR WORKMANSHIP.

Subject to proper installation and normal Residential use, Escalade® Sports warrants, subject to the limitations below, to the original retail purchaser all structural components of the Goalrilla™ System to be free of defects in material and workmanship for the duration of ownership by the original retail purchaser.

Merchandise must be shipped prepaid with a copy of proof of purchase to Escalade® Sports factory for examination to determine if the basketball system needs to be repaired or replaced. Any labor costs, travel expenses and any other changes involved in the removal, installation or replacement of the defective/repaired parts from/to your Goalrilla™ System will be the purchaser's responsibility. Shipping charges for replaced or warranted merchandise sent back to the customer from Escalade® Sports factory must be prepaid by the customer in advance. If not, the replacement shipment will be sent out collect.

Escalade® Sports reserves the right to examine photographs or physical evidence of merchandise claimed to be defective, and to recover said merchandise, prior to authorization of warranty claims. A "Returned Goods Authorization" number may be required, please call for details prior to the return of any photographs or merchandise.

This limited lifetime warranty is expressly in lieu of all warranties, expressed or implied, including warranties of merchantability or fitness for use. Escalade® Sports does not assume or authorize any person or representative to assume for us, any other liability in connection with the sale of our products.

The remedy of repair or replacement stated above is Escalade® Sports exclusive remedy. Escalade® Sports will not be liable for any other damages or expenses which may incur, including but not limited to incidental or consequential damages. Escalade® Sports assumes no other obligations or liability on the part of the purchaser, and Escalade® Sports neither assumes nor authorizes any other person to assume for it any other liability in connection with the goods sold.

This warranty shall not apply in any manner to parts or accessories not manufactured by Escalade® Sports.

### NOT COVERED BY THIS WARRANTY

- Merchandise not intended to be in places of public assembly, such as, but not limited to, schools, parks, public or private recreational facilities.
- Any merchandise subjected to Non-residential abuse, negligence, improper installation, vandalism, acts of God, alteration of product, or any other events beyond the control of Escalade® Sports.
- Paint or rusted parts. If rust should appear, remove loose paint, sand lightly, primer and paint with exterior flat matte finish enamel paint.
- Rims are not warranted for any defects other than workmanship. Torn back plates, damaged springs, bent rings, damaged eyebolts, and torn or distorted rim supports result from hanging on the rim and are not warranted.
- Shipping charges both ways. Note: Any merchandise shipped to Escalade® Sports collect will be refused.
- Dealer service charges, labor charges and travel expenses associated with replacement of repair of warranty item.

**WARRANTY DISCLAIMERS:** ANY IMPLIED WARRANTIES ARISING OUT OF THIS SALE, INCLUDING BUT NOT LIMITED TO THE IMPLIED WARRANTIES OF MERCHANTABILITY AND FITNESS FOR A PARTICULAR PURPOSE, ARE LIMITED IN DURATION. ESCALADE® SPORTS SHALL NOT BE LIABLE FOR LOSS OF USE OF THE PRODUCT OR OTHER CONSEQUENTIAL OR INCIDENTAL COSTS. EXPENSES OR DAMAGES INCURRED BY THE CONSUMER OF ANY OTHER USE.

Some states do not allow the exclusion or limitation of implied warranties or consequential or incidental damages, so the above limitations or exclusions may not apply to you.

LEGAL REMEDIES: This warranty gives you specific legal rights, and you may also have other rights which may vary from state to state.

### WARRANTY GUIDELINES IS REQUIRED FOR ALL WARRANTY CLAIMS

1. Proof of Purchase (original retail purchaser) is required for all warranty claims.
2. Call or write Escalade® Sports to receive a Return Authorization # and determine specific needs.

Phone: 1-888-USA-GOAL / Warranty Dept.

Or Write Escalade® Sports at: Escalade® Sports - P.O. Box 889, Evansville, IN 47706 - Attn: Warranty Dept.

Or E-mail us at: [customerservice@escaladesports.com](mailto:customerservice@escaladesports.com)