







HEKMAN

ASSEMBLY INSTRUCTIONS 23823 - UPH SIDE CHAIR

X A HOWARD MILLER COMPANY

A		13mm	P c
B		5 / 16 " x 1 2 . 6 5	x 8 . 5 m m
C		5 / 16 "	9 P s
D		x 3 9 m m	9 P s
E		x 3 8 m m	1 P s
F		x 5 7 m m	P c s
H		5mm	P c

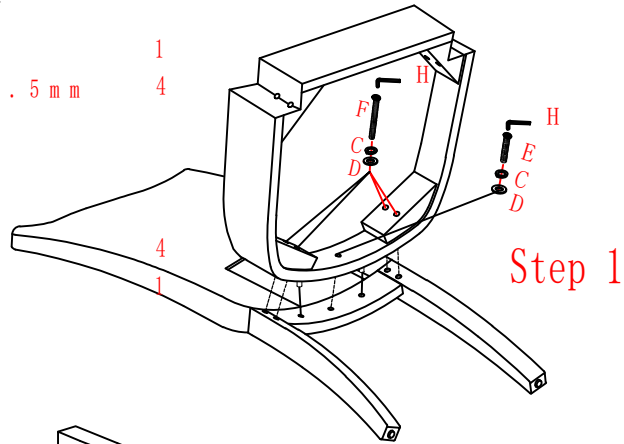

Step 1

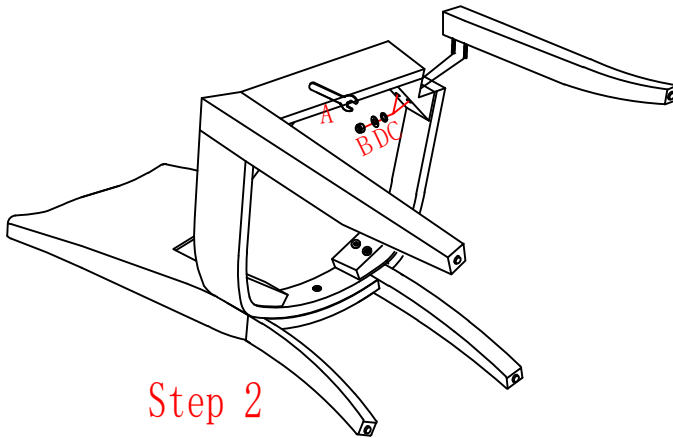

Step 2

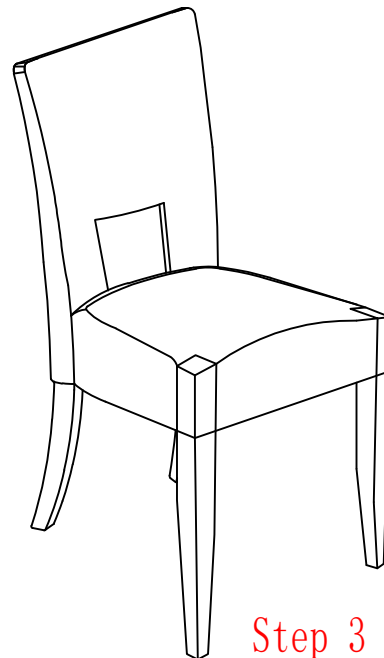

Step 3

Step 1: Assemble the back frame and the chair seat together with Bolt (E, F), Spring Washer (C) and Flat washer (D) using Wrench (H).

Step 2: Assemble the front legs to the chair with Hex Nut (B), Spring Washer (C) and Flat washer (D) using Wrench (A). Do Not tighten the screws or nuts completely.

Step 3: Set the chair upright on a flat surface. Adjust the front legs so all four chair legs touch the floor, tighten nuts completely on the front legs.

MADE IN CHINA