



Model 500XL

Water Pressure Reducing Valve with Integral By-pass Check Valve

Application

Zurn Wilkins model 500XL designed for installation on potable water lines to reduce high inlet pressure to a lower outlet pressure. The high flow capacity makes this device most suitable for industrial water lines and commercial water systems. The direct acting integral by-pass design prevents buildup of excessive system pressure caused by thermal expansion. The balanced piston design enables the regulator to react in a smooth and responsive manner to changes in system flow demand, while at the same time, providing protection from inlet pressure changes.

Standards Compliance

- ASSE® Listed 1003 (1/2" thru 2 1/2")
- cUPC® Listed (1/2" thru 2")
- CSA® Certified B356 (1/2" thru 2")
- City of Los Angeles Approved (1/2" thru 2")
- Meets the requirements of NSF/ANSI/CAN 61 and 372*
*(Less Than 0.25% Weighted Average Lead Content)

Materials

Main valve body	Low Lead Cast bronze	ASTM B 584
Access covers	Low Lead Cast bronze	ASTM B 584
	Low Lead Brass	
Fasteners	Stainless steel, 300 series	
Stem & plunger	Low Lead Cast bronze	ASTM B 584
	Low Lead Brass	
Elastomers	Buna Nitrile (FDA approved)	
	EPDM (FDA approved)	
Cap gaskets	Natural vulcanized fibre	
	Acetal (Delrin™ 500)	
Springs	Oil tempered wire, ASTM A 229	
Seat	Stainless steel, 300 series	

Features

Sizes:	1/2", 3/4", 1", 1 1/4", 1 1/2", 2", 2 1/2", 3"
Maximum working water pressure	300 psi
Maximum working water temperature	140° F
Reduced pressure range	25 psi to 75 psi
Factory preset (field set 2 1/2" & 3")	50 psi
Threaded connections (FNPT)	ANSI B1.20.1
Copper connections (FC)	ANSI B 16.22
CPVC tailpiece: Max.hot water temp.	140°F @ 100 psi
	Cold water rated temp. 73.4°F @ 400 psi

Dimensions & Weights (do not include pkg.)

SIZE		CONNECTIONS	DIMENSIONS (approximate)								WEIGHT	
in.	mm		A		B		C		D		lbs.	kg.
1/2	15	SINGLE UNION	4 1/2	108	6	152	1 5/8	41	2 3/4	70	3	1.5
3/4	20	SINGLE UNION	4 5/8	118	6	152	1 1/8	29	2 3/4	70	4	2.0
1	25	SINGLE UNION	5 1/8	130	6 7/8	175	1 5/8	41	3 5/16	84	6	3.0
1 1/4	32	SINGLE UNION	6 5/16	160	7 1/4	184	1 3/4	45	4	102	7	3.0
1 1/2	40	SINGLE UNION	8 5/16	211	10	254	1 7/8	48	5	127	14	6.5
2	50	SINGLE UNION	9 1/2	241	10 3/4	273	2 1/8	54	6 1/2	165	20	9.0
2 1/2	65	LESS UNION	9 7/8	251	14 1/2	368	3	76	8	203	28	12.5
3	80	LESS UNION	10 15/16	278	16	406	3 1/2	89	8	203	44	20.0

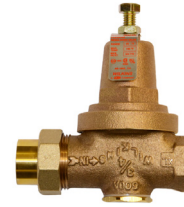

Options

(Suffixes can be combined)

- standard with single union FNPT inlet x FNPT outlet (1/2" thru 2") and less union (2 1/2" & 3")
- C - copper sweat connection (1/2" thru 2")
copper sweat strainer 3/4" & 1" only
All other strainers are FNPT
- L - less integral by-pass check valve (3/4"-2")
- HR - 75 psi to 125 psi spring range, factory set at 85 psi (field set 2 1/2" & 3")
- HLR - 10 psi to 125 psi spring range, factory set at 50 psi
- HTSTSC - 180°F maximum temp, stainless steel trim, spring, sealed cage
- LPV - 180°F maximum temp with 10 psi to 35 psi spring range, factory set at 20 psi
- SC - sealed cage bell housing and stainless steel adjustment screw
- SW - made for salt water service
- YSBR - with lead-free bronze "Y" strainer on inlet
- 510XL - 400 psi inlet rating and 75 psi to 125 psi spring range, factory set at 85 psi (field set 2 1/2" & 3")
- P - tapped and plugged for gauge
- G - tapped and plugged with gauge
- CPVC - CPVC tailpiece connection (3/4"-1")

Accessories

- Repair kit (rubber only)

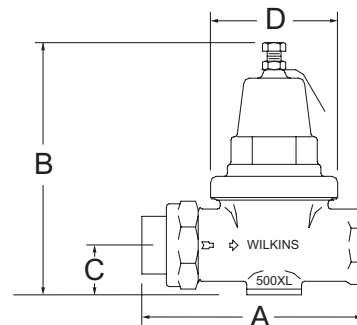

MODEL 500XL 1/2" THRU 3" (STANDARD & METRIC)

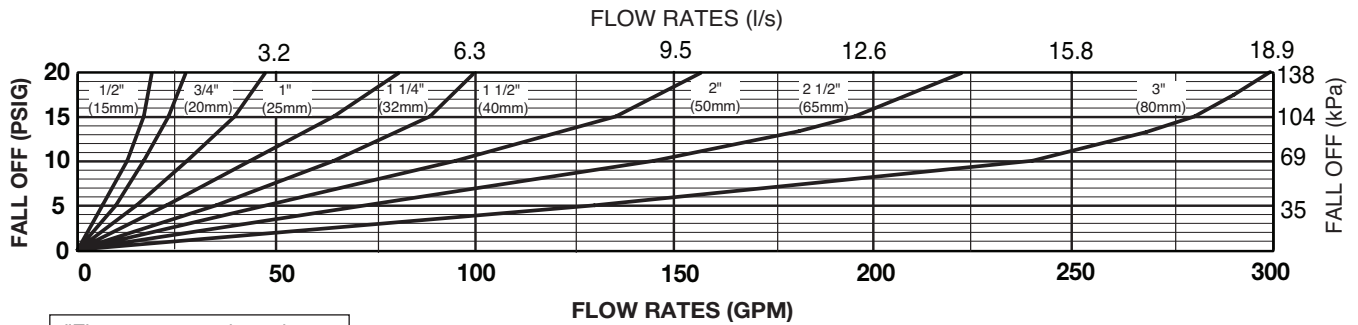

"Flow curves are based on a 50 psi pressure differential"

Typical Installation

Local codes shall govern installation requirements. Unless otherwise specified, the assembly shall be mounted in accordance with the manufacturers' instructions and the latest edition of the Uniform Plumbing Code. The assembly shall be installed with sufficient side clearance for testing and maintenance. The Model 500XL may be installed in any position. If installed in a pit, vault, or inside application, specify the "SC" sealed cage option. Multiple installations are recommend for wide demand variations or where the desired pressure reduction is more than 3 to 1 (i.e.: 150 psi inlet reduced to 50 psi outlet).

Caution: Anytime a reducing valve is adjusted, a pressure gauge must be used downstream to verify correct pressure setting. Do not bottom adjustment bolt on bell housing.

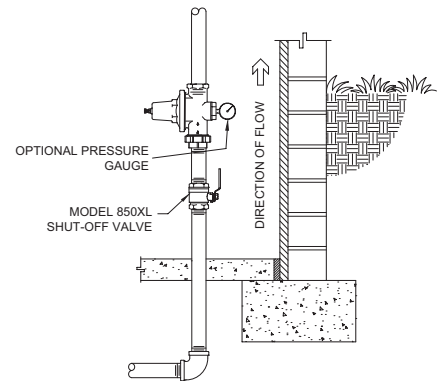
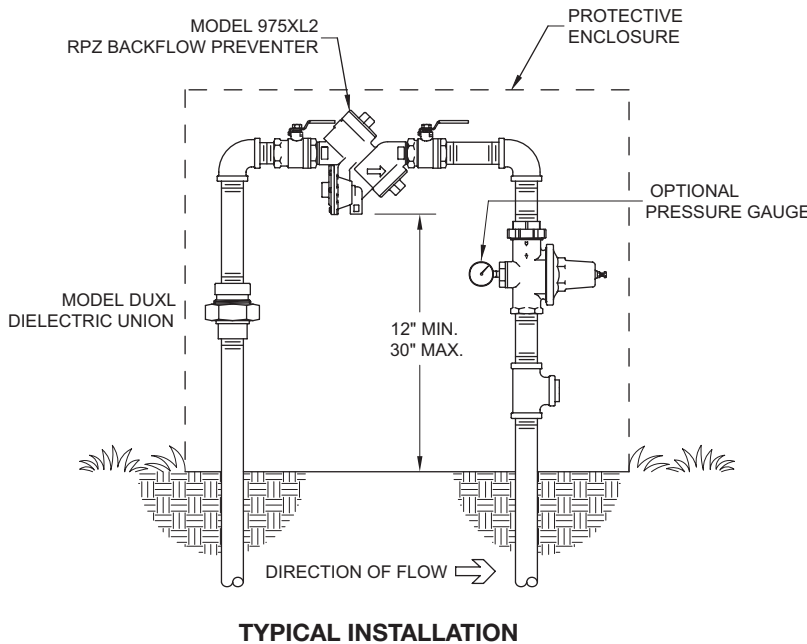

VERTICAL INSTALLATION

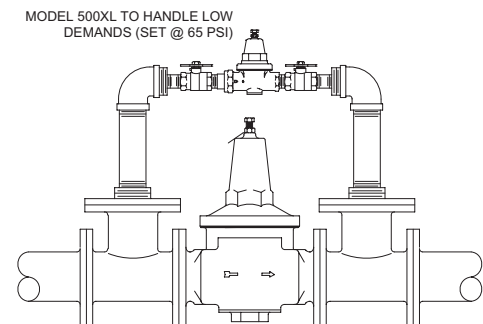

BATTERY INSTALLATION

Specifications

The Pressure Reducing Valve shall be certified to NSF/ANSI/CAN 61, consisting of a low lead bronze body and bronze bell housing, a separate access cover for the plunger and a bolt to adjust the downstream pressure. The bronze bell housing and access cap shall be threaded to the body and shall not require the use of ferrous screws. The assembly shall be of the balanced piston design and shall reduce pressure in both flow and no-flow conditions. The assembly shall be accessible for maintenance without having to remove the body from the line. The Pressure Reducing Valve shall be a ZURN WILKINS Model 500XL.