

2306196B 20x20 Kingsport Carport Container Loading Diagram

(1 set=11 boxes 26 sets/40HQ, 16 pallets/ 40HQ, Gross weight:20812kg)

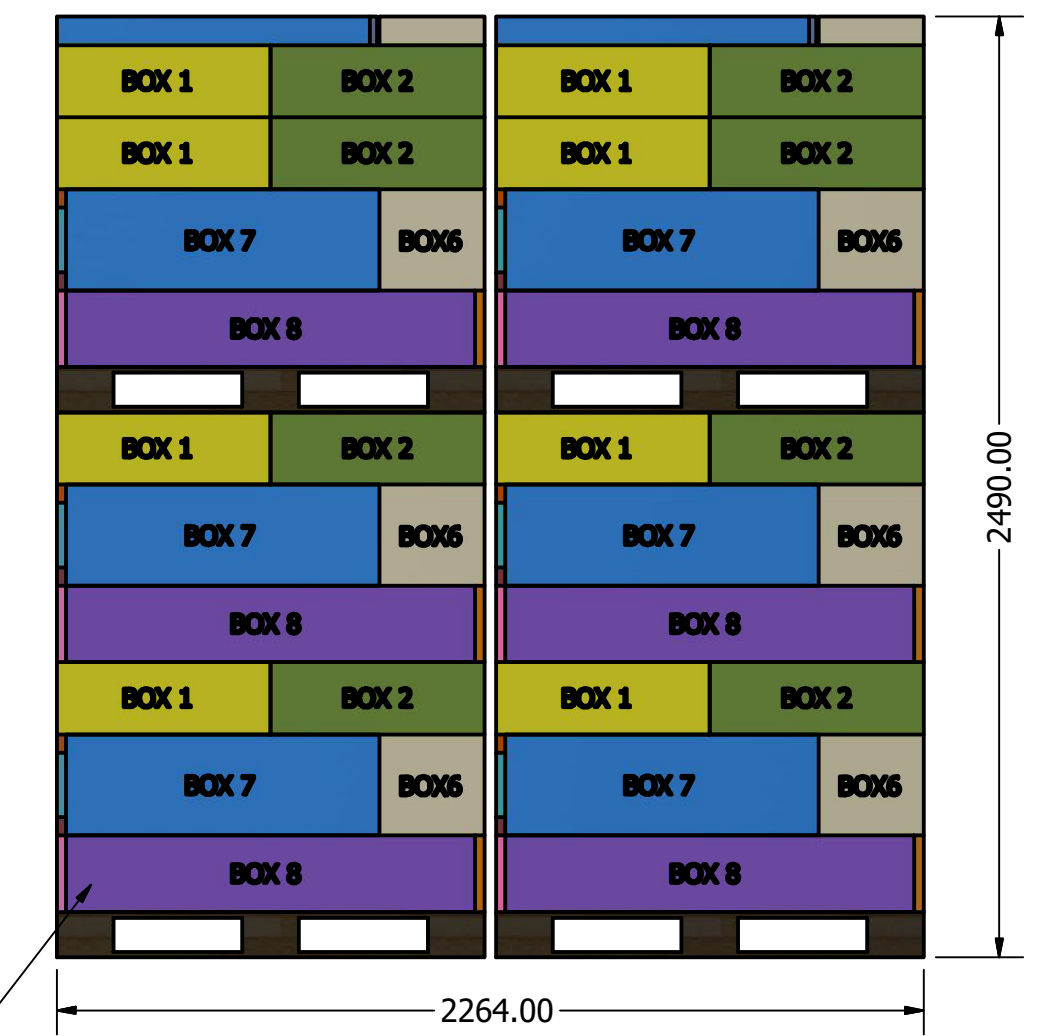
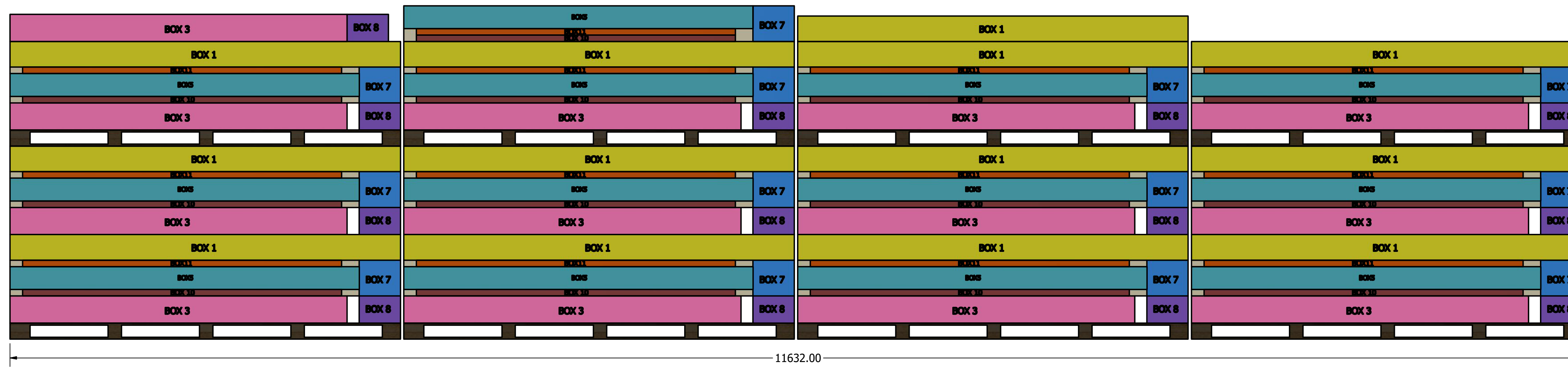
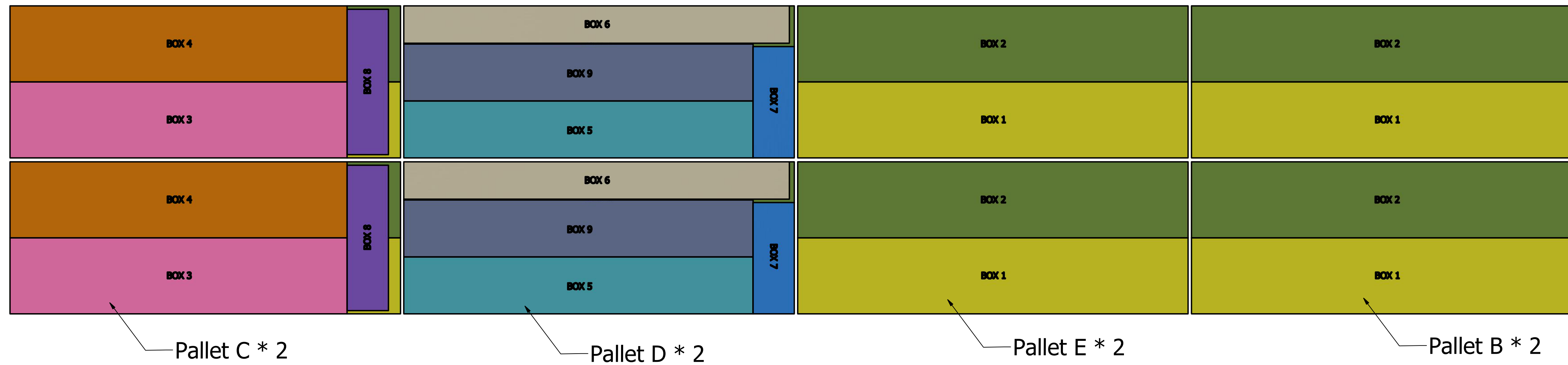
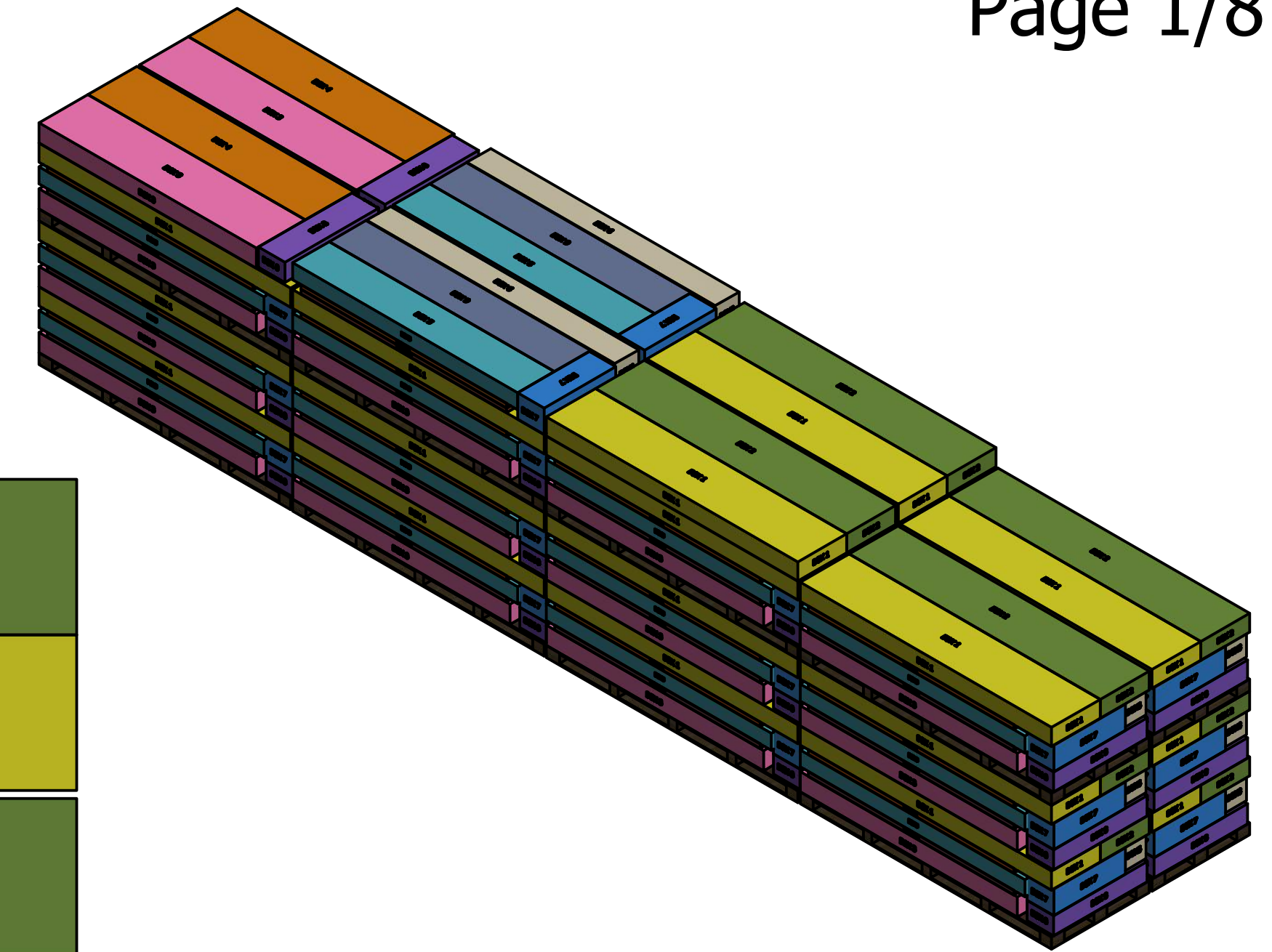

- Pallet A * 8
- Pallet B * 2
- Pallet C * 2
- Pallet D * 2
- Pallet E * 2

Pallet A * 8

DRAWN Rudy		TITLE		
CHECKED				
QA				
MFG				
APPROVED				
		SIZE D	DWG NO	REV
		SCALE 1:20	SHEET 1 OF 1	

Pallet A (2 sets)

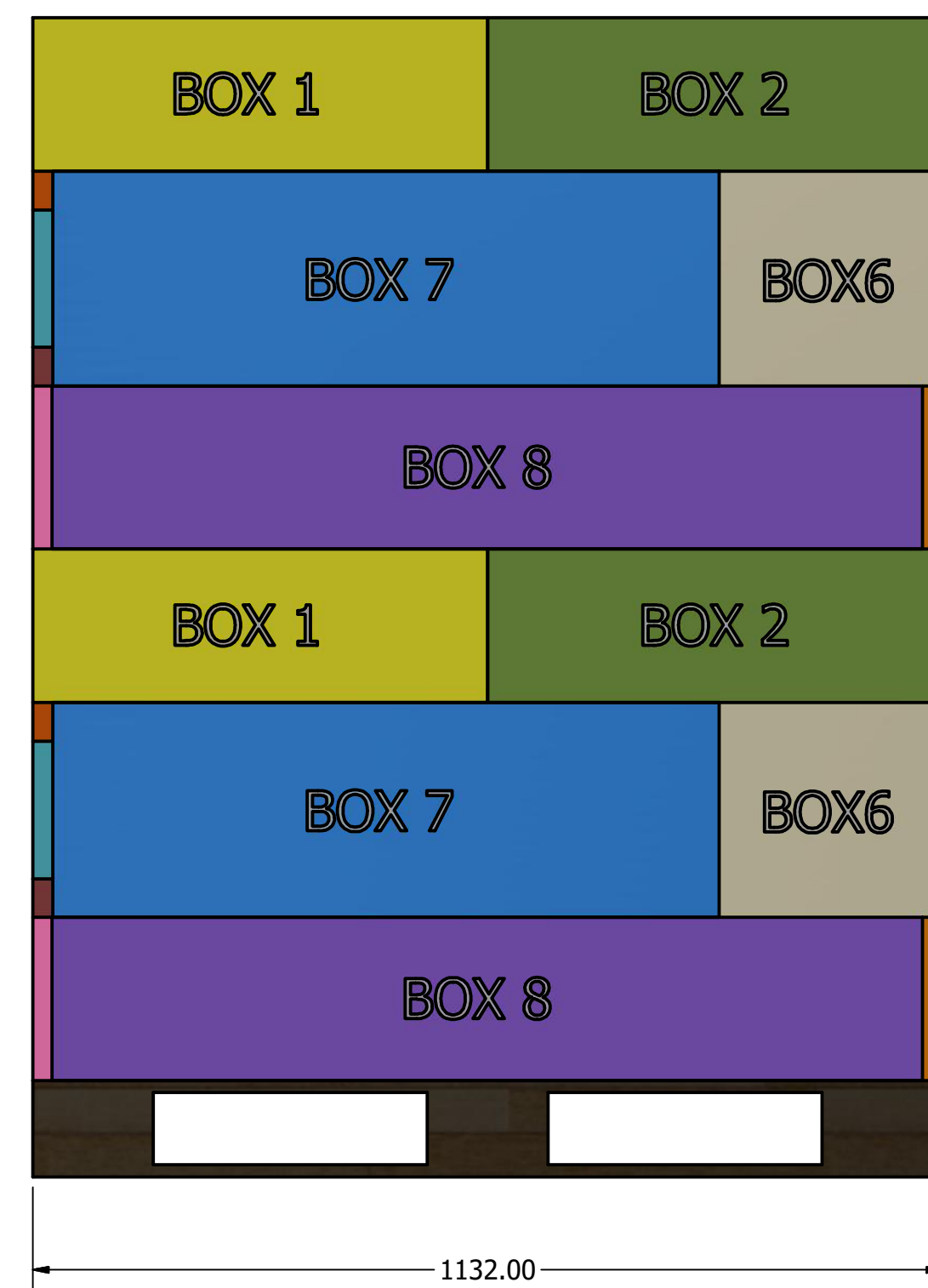
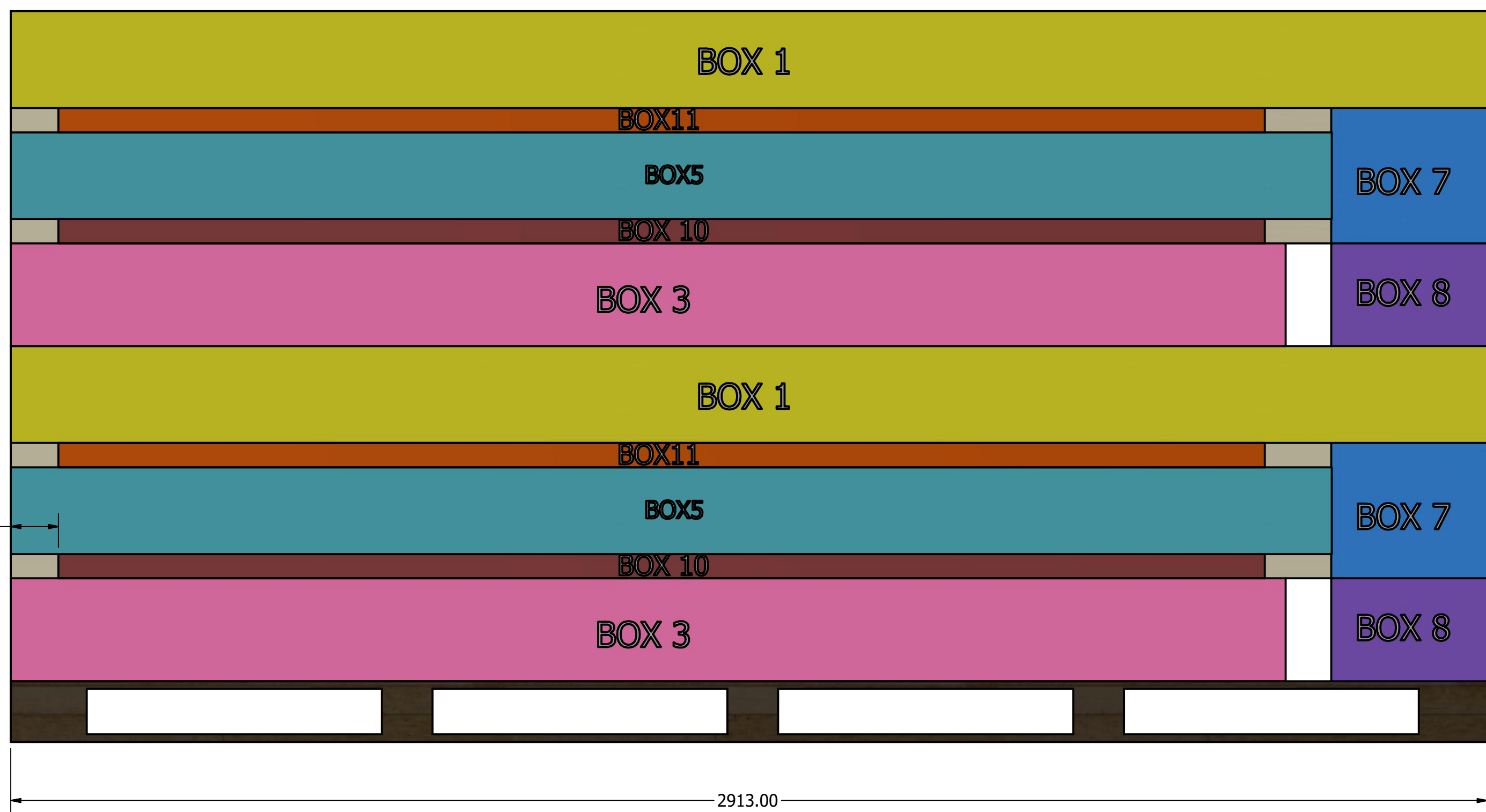
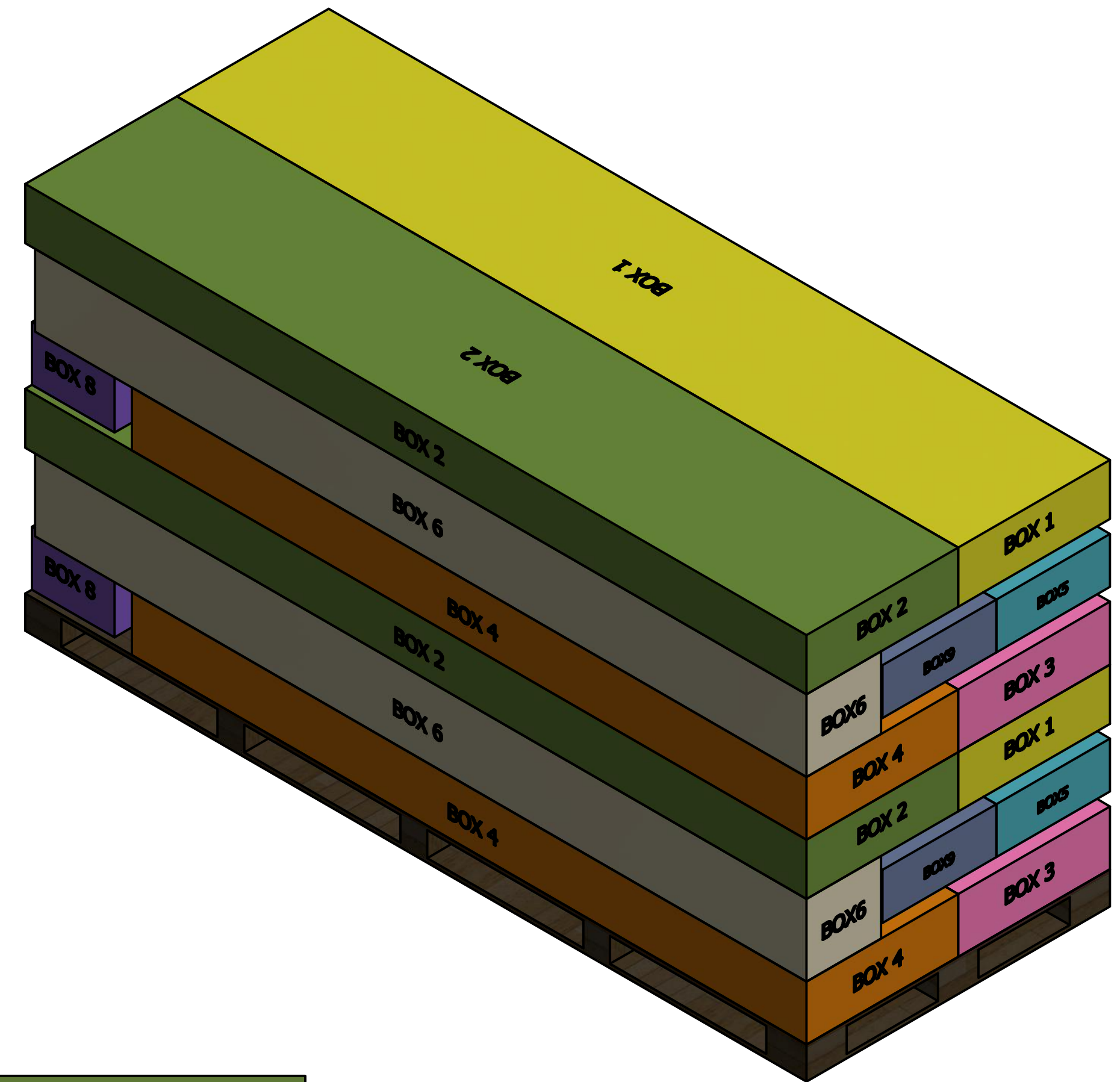

DRAWN Rudy		TITLE		
CHECKED		TITLE		
QA		TITLE		
MFG		TITLE		
APPROVED		TITLE		
		SIZE D	DWG NO Pallet A	REV
		SCALE 1 : 8	SHEET 1 OF 1	

Pallet A

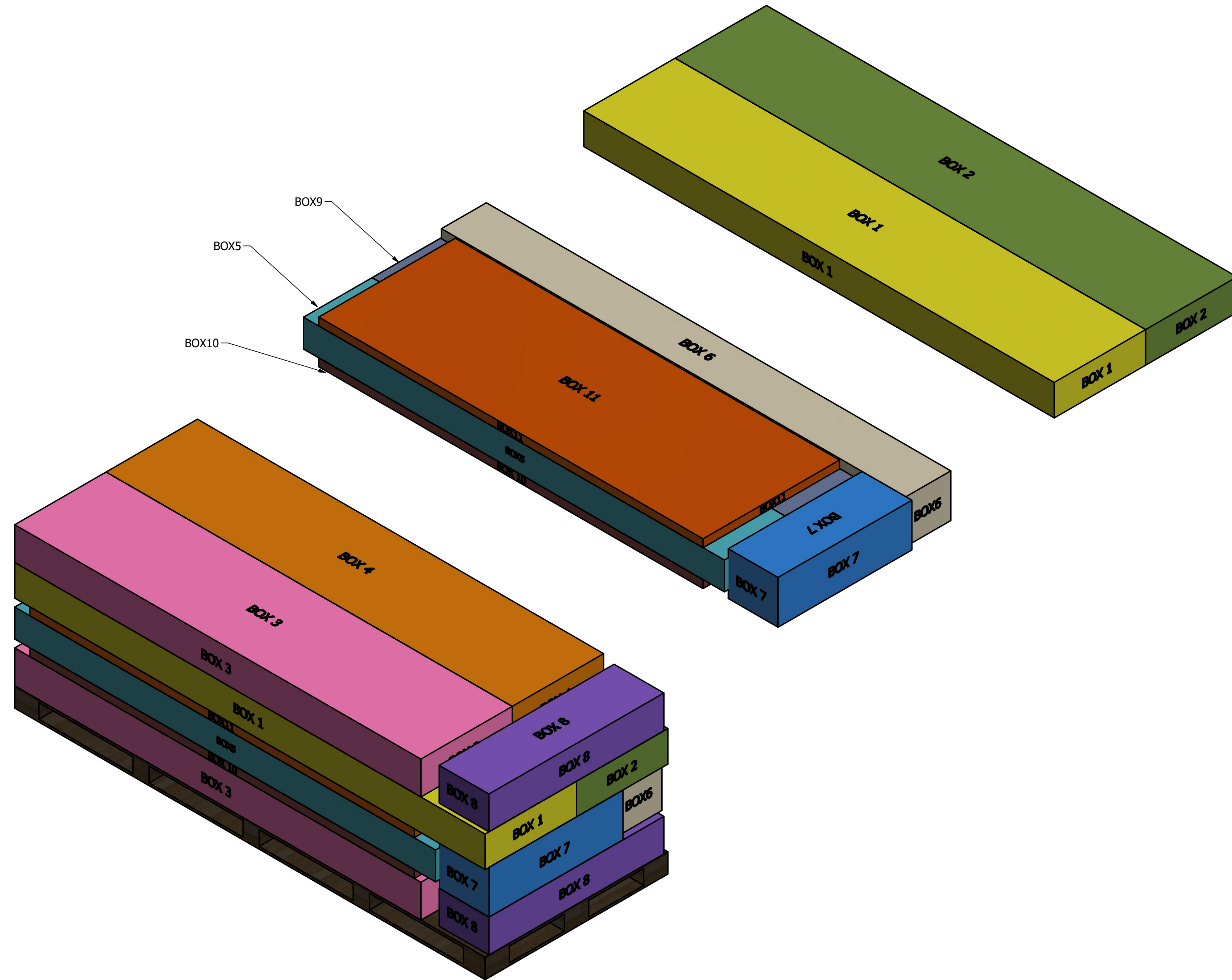

DRAWN Rudy				
CHECKED		TITLE		
QA				
MFG				
APPROVED				
		SIZE D	DWG NO Pallet A	REV
		SCALE 1 : 12	SHEET 1 OF 1	

Pallet B (1 set)

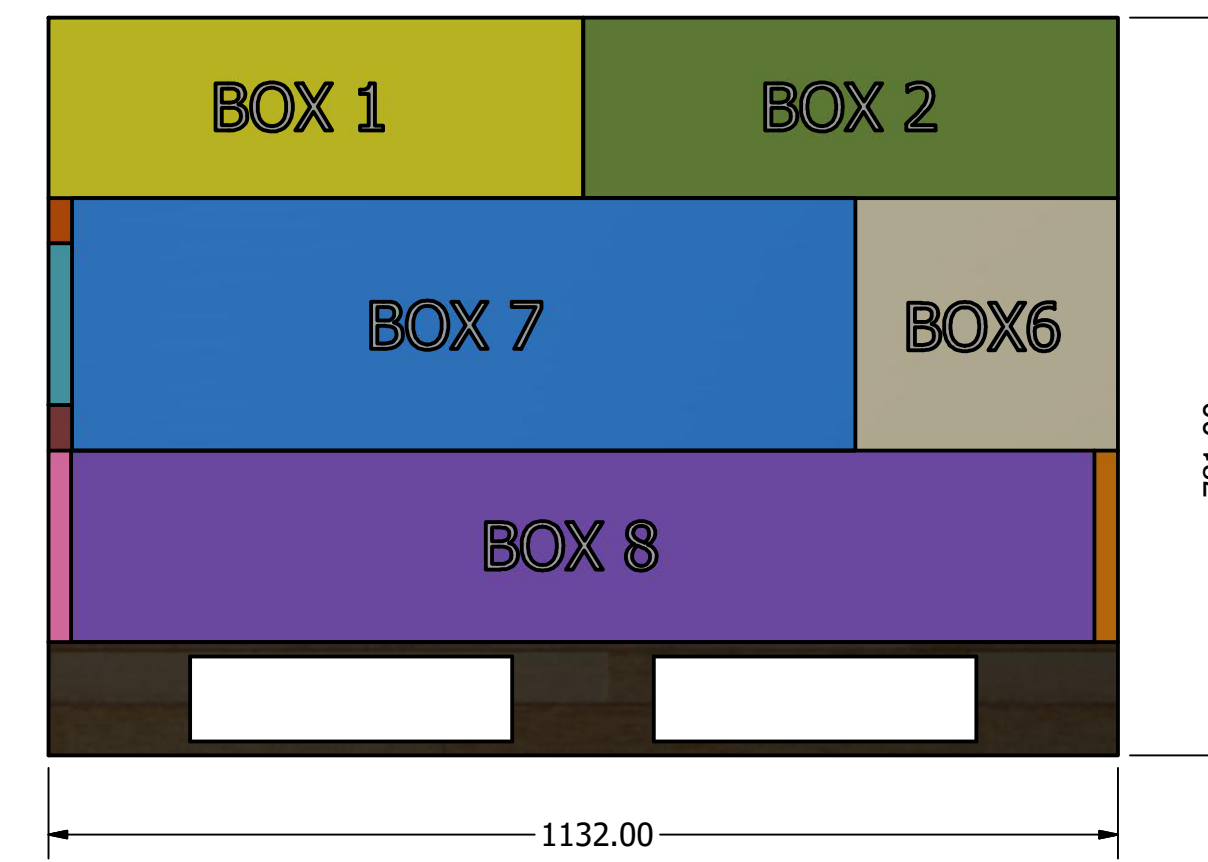
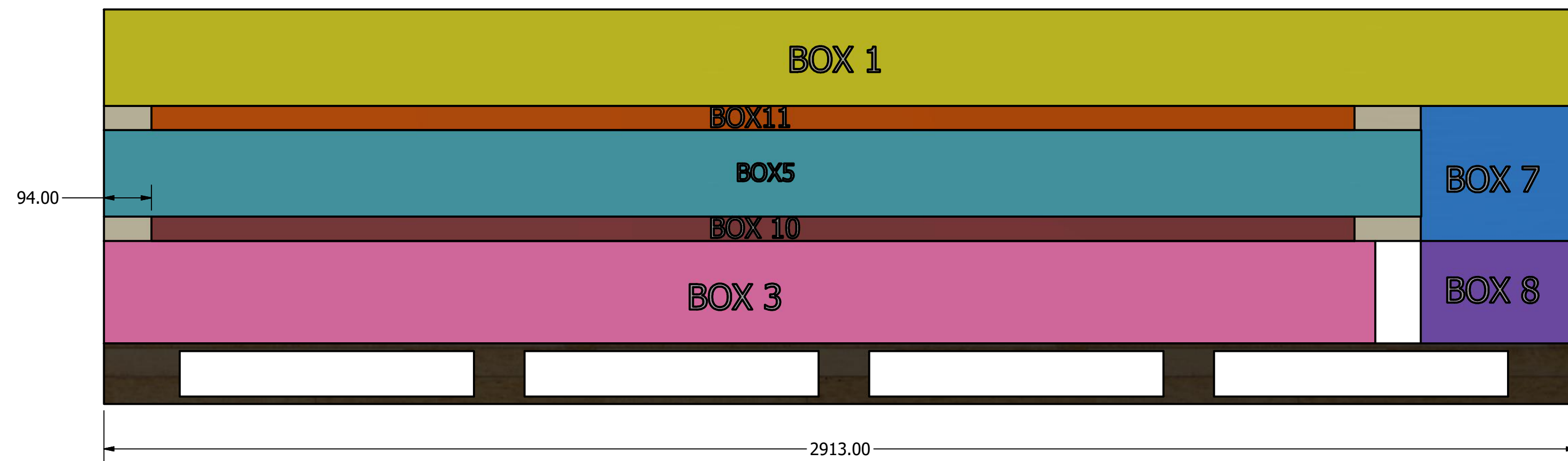
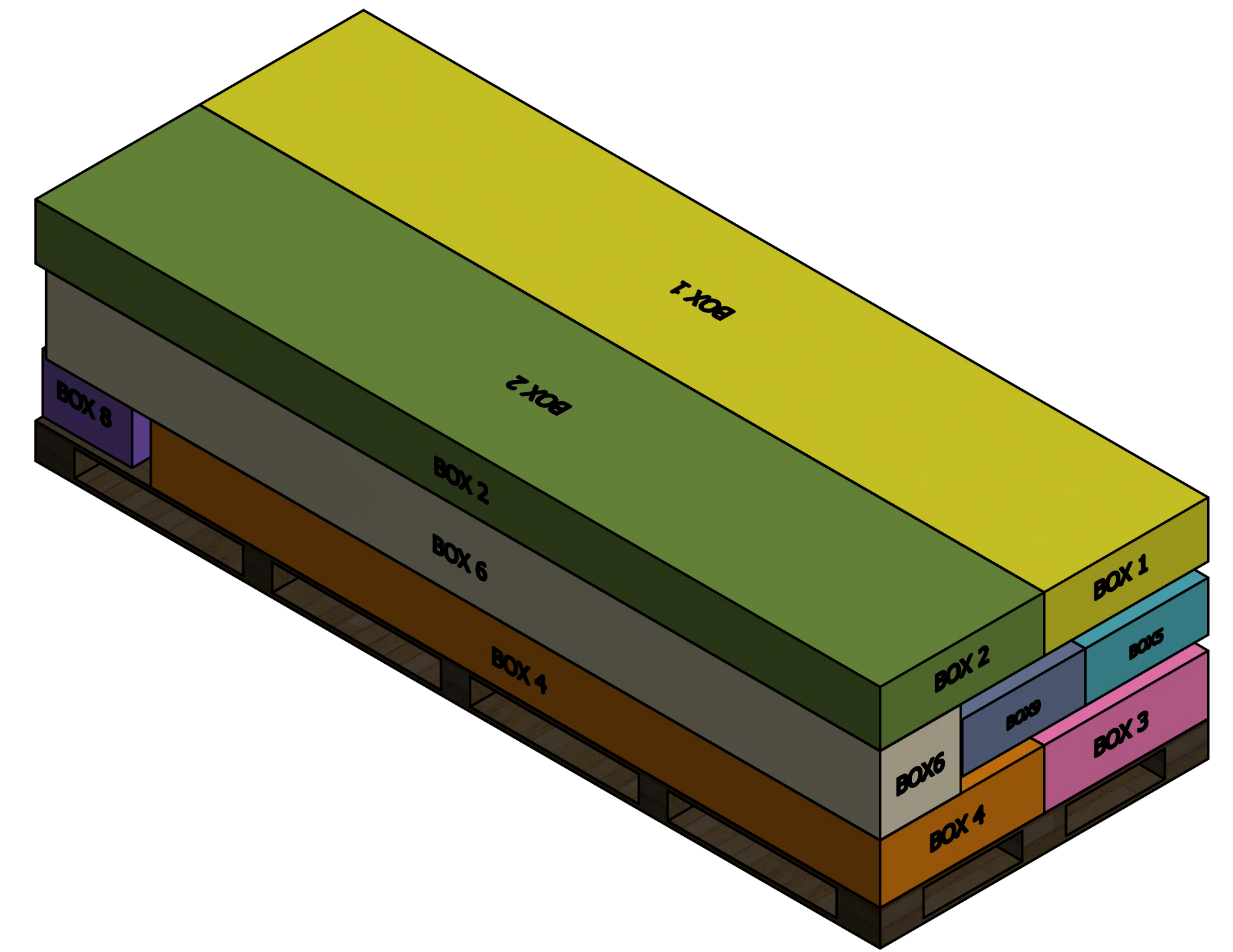
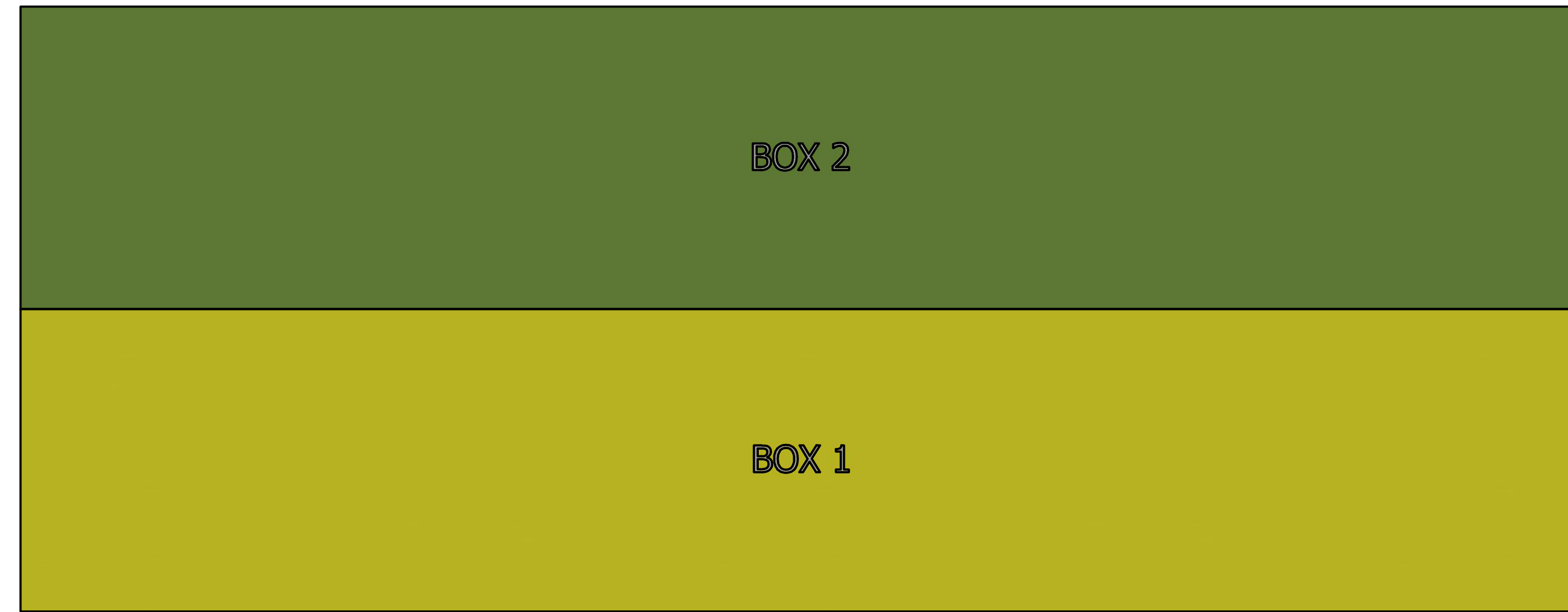

DRAWN Rudy		TITLE		
CHECKED				
QA				
MFG				
APPROVED		SIZE D	DWG NO Pallet A	REV
		SCALE 1 : 8	SHEET 1 OF 1	

Pallet C (1 1set+3boxes)

Note:
 Pallet C needs to be additionally bundled in the length direction after stacking to fix the BOX8 on the top.
 托盘C需要在堆叠好后在长度方向额外进行捆绑, 以固定住顶部的8号盒.

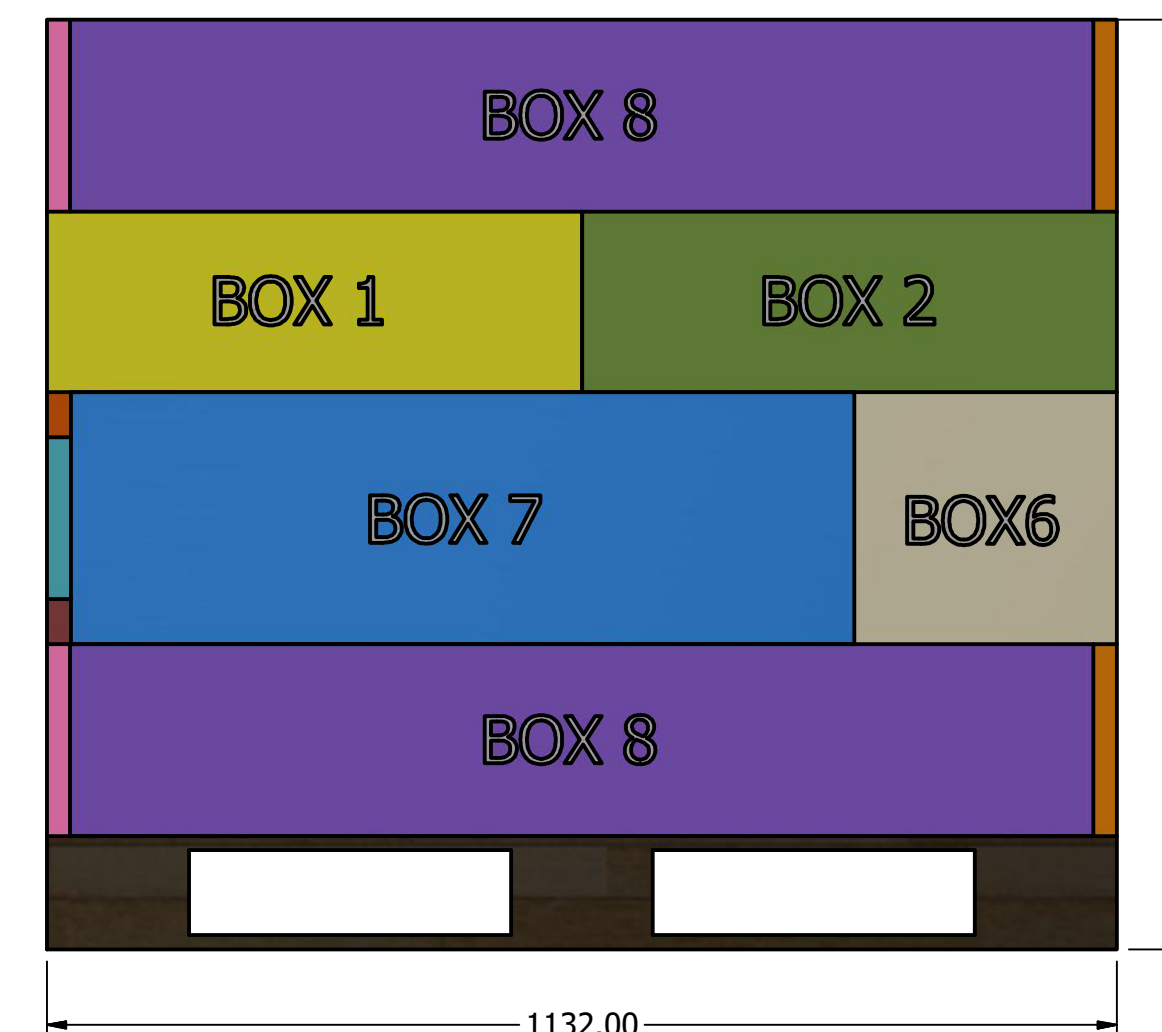
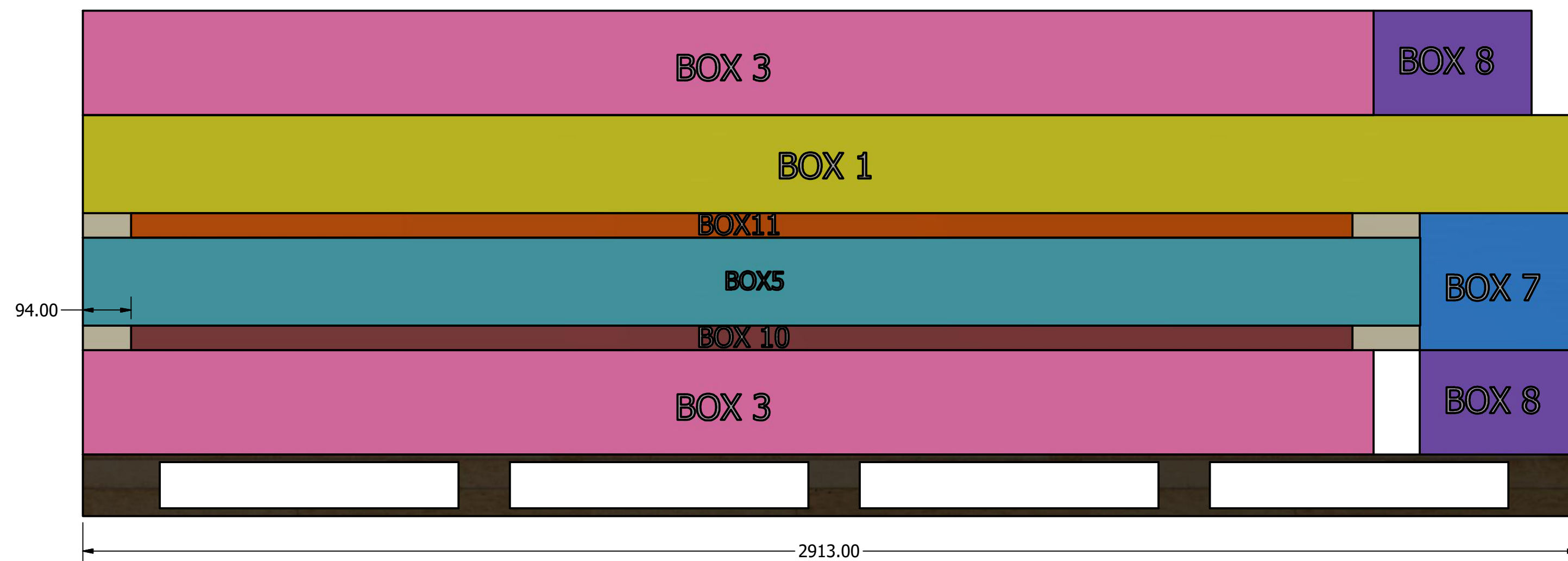
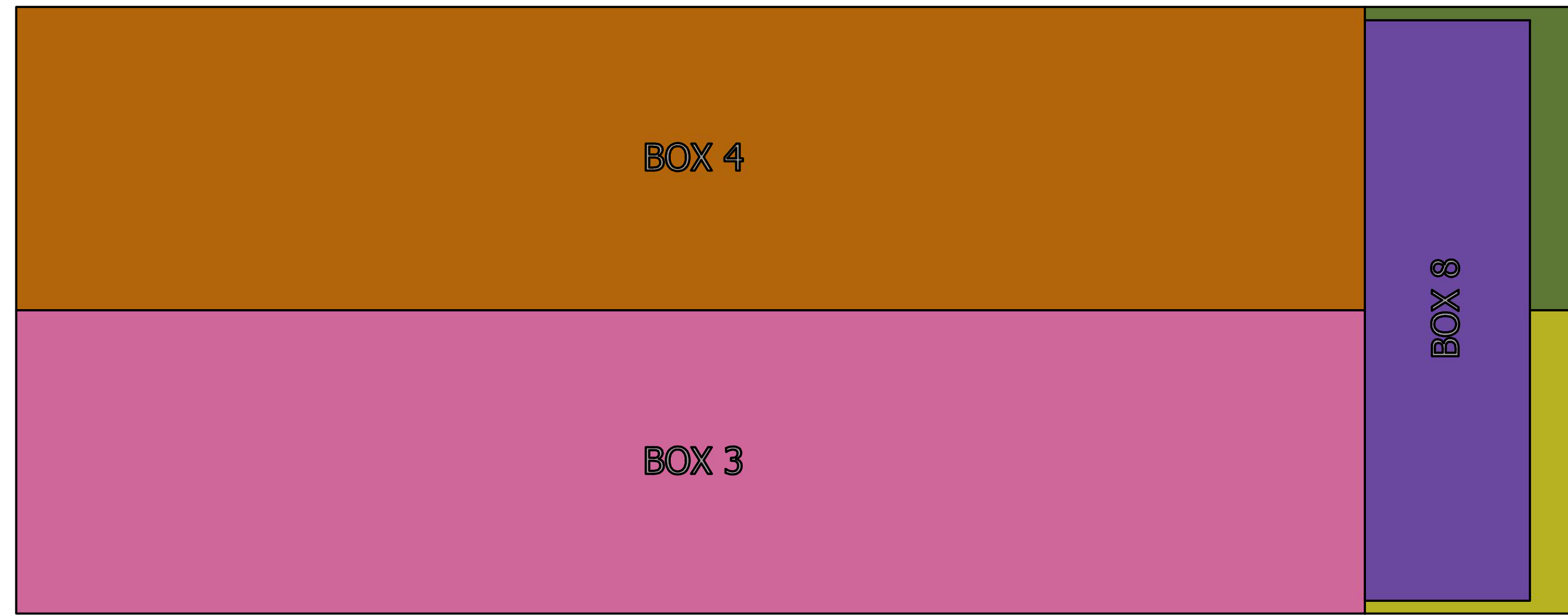
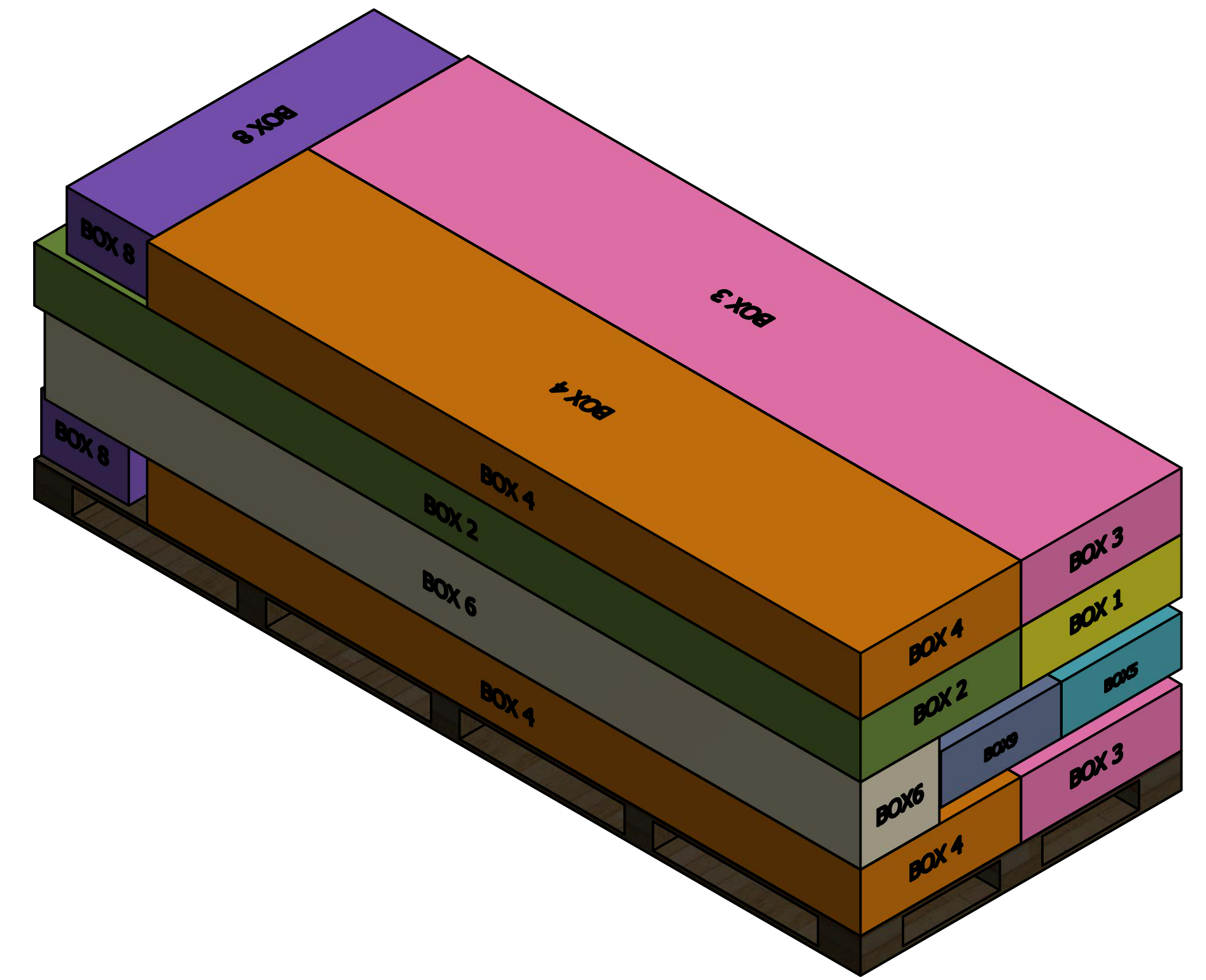

DRAWN Rudy		TITLE	
CHECKED			
QA			
MFG			
APPROVED			
		SIZE D	DWG NO Pallet A
		SCALE 1 : 8	REV
		SHEET 1 OF 1	

Pallet D (1 set+6 boxes)

Note:
 Pallet D needs to be additionally bundled in the length direction after stacking to fix the BOX7 on the top.
 托盘D需要在堆叠好后在长度方向额外进行捆绑, 以固定住顶部的7号盒.

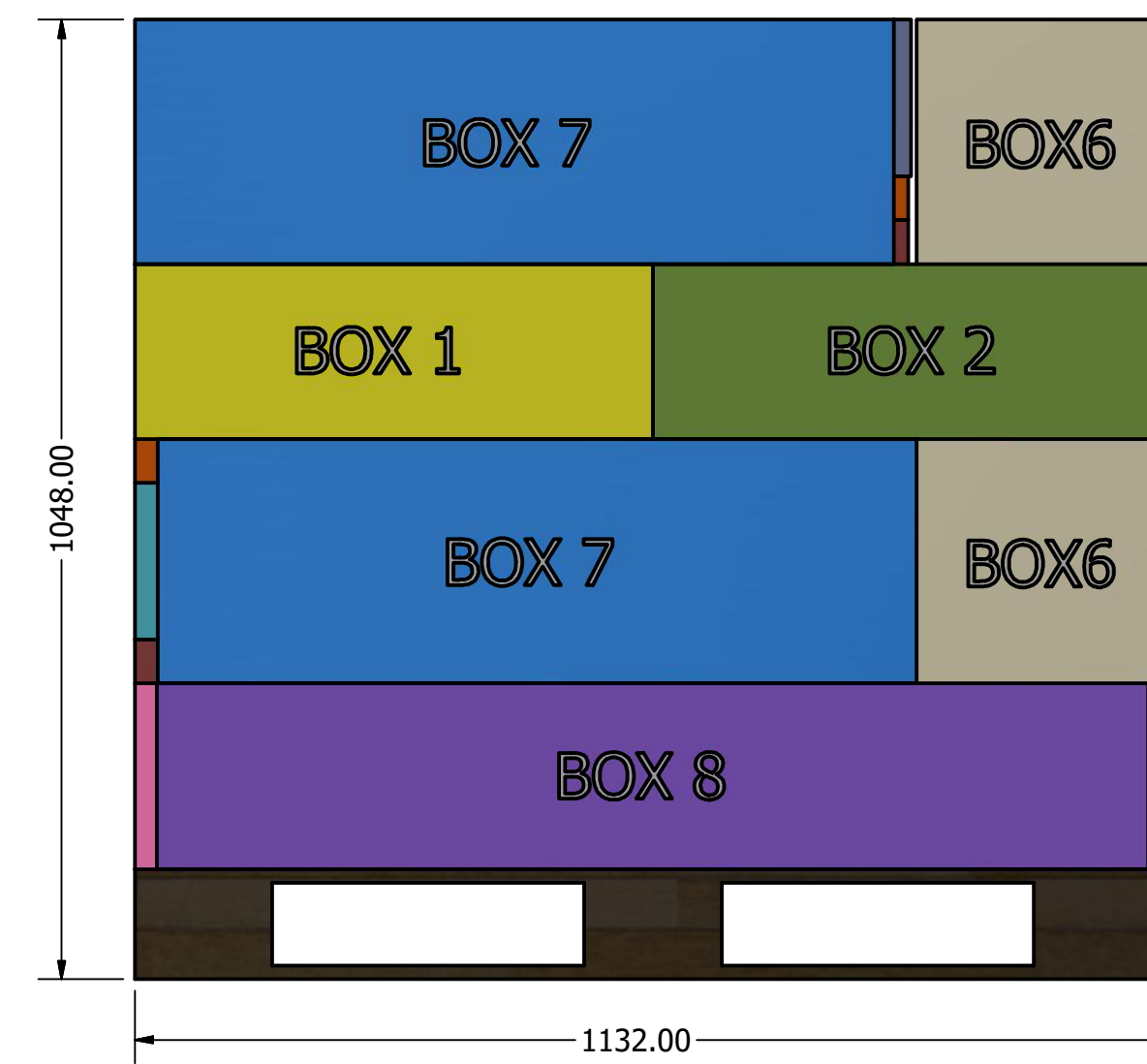
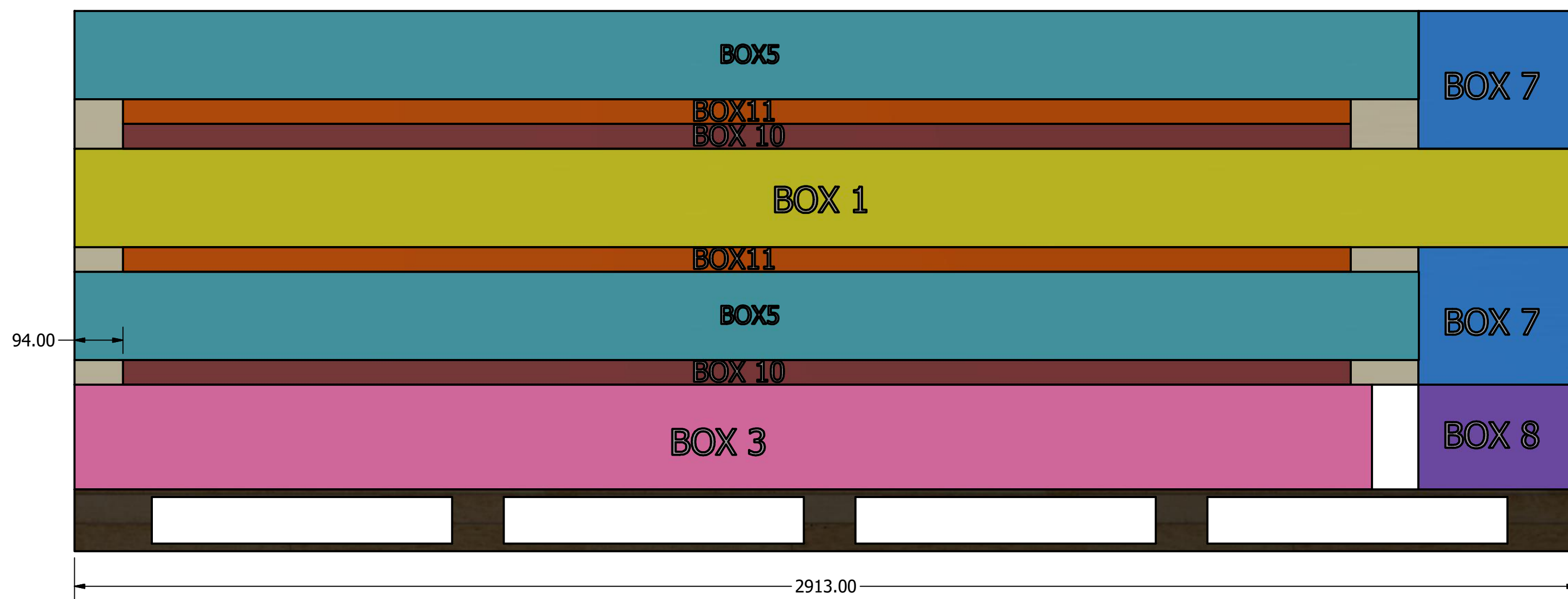
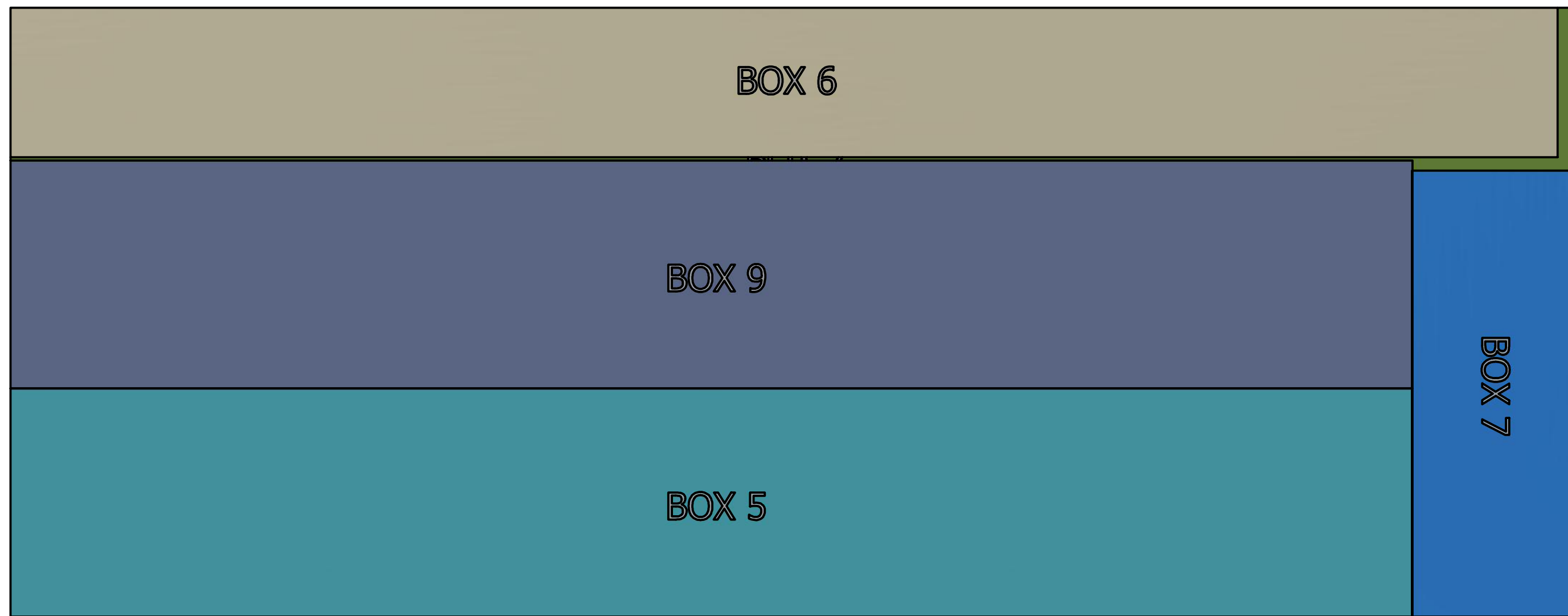
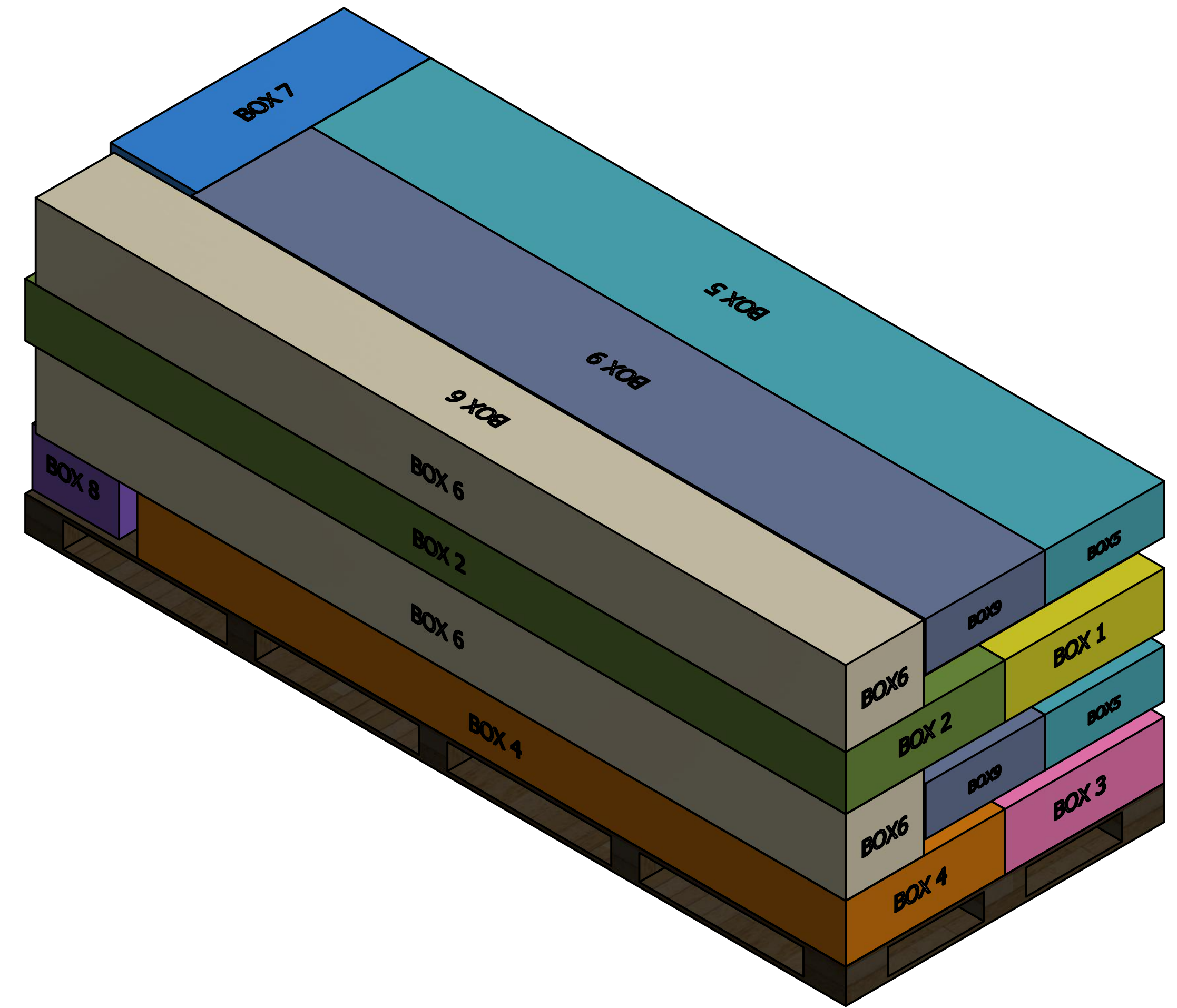

DRAWN Rudy		TITLE	
CHECKED			
QA			
MFG			
APPROVED			
		SIZE D	DWG NO Pallet A
		SCALE 1 : 8	REV
		SHEET 1 OF 1	

Pallet E (1set+2boxes)

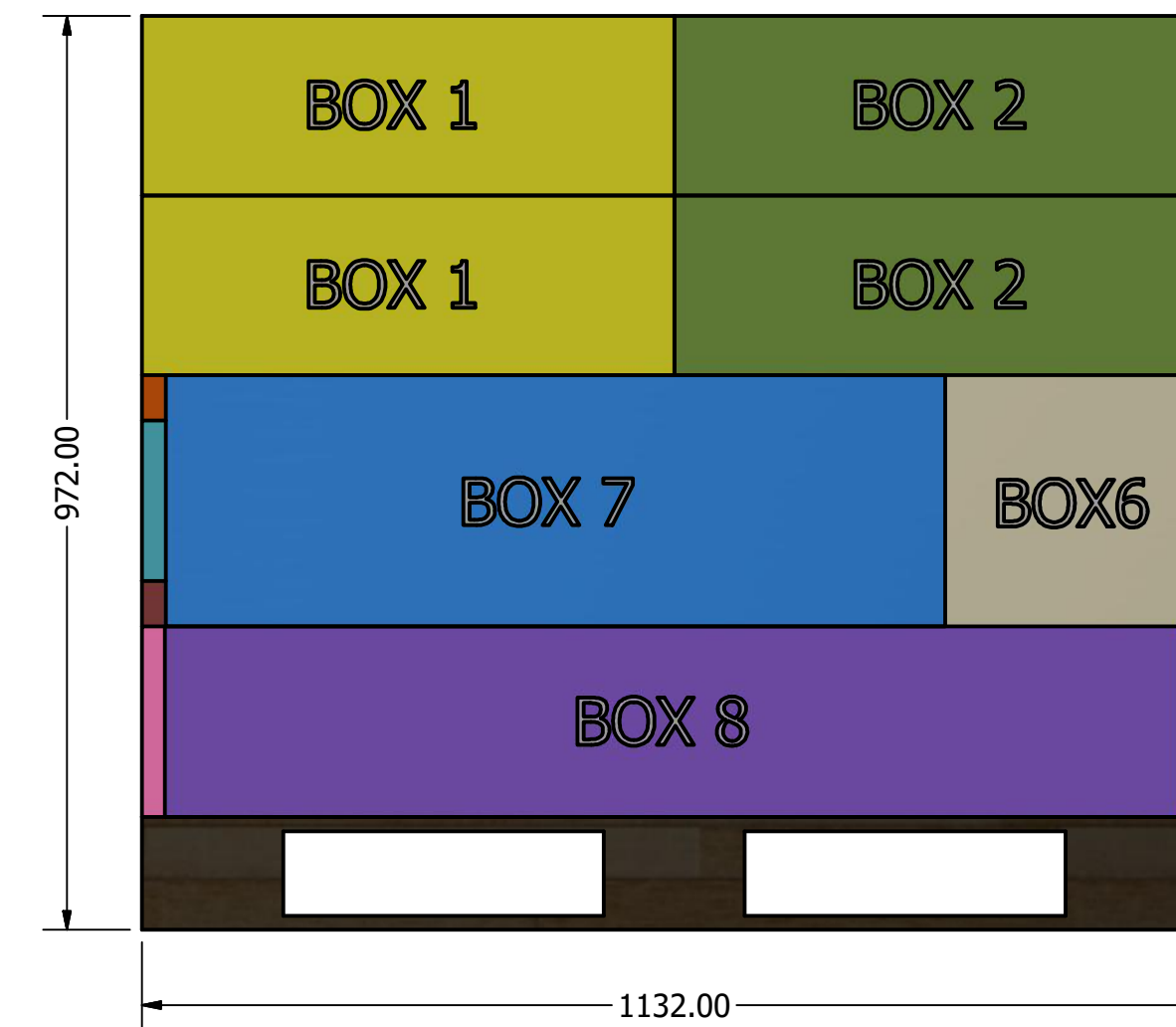
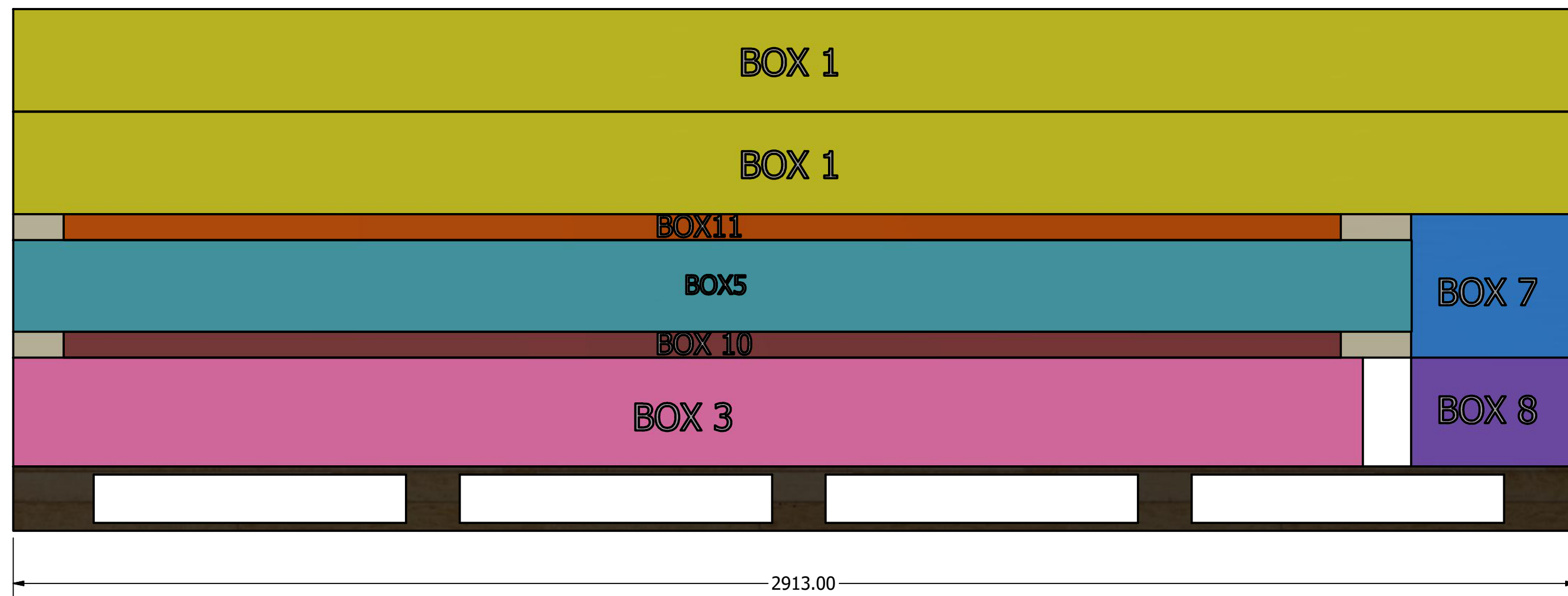
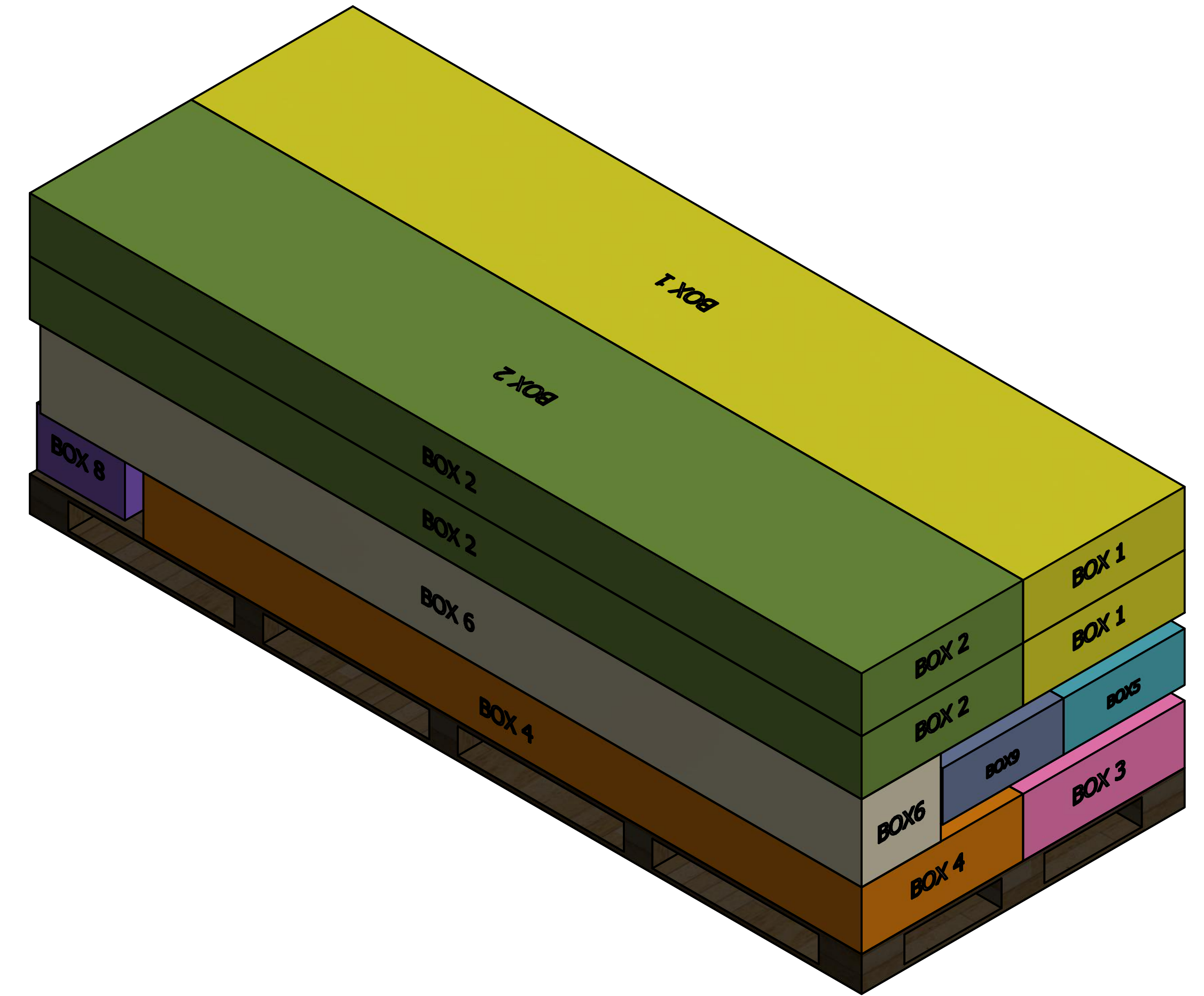

DRAWN Rudy		TITLE		
CHECKED				
QA				
MFG				
APPROVED		SIZE D	DWG NO Pallet A	REV
		SCALE 1 : 8	SHEET 1 OF 1	

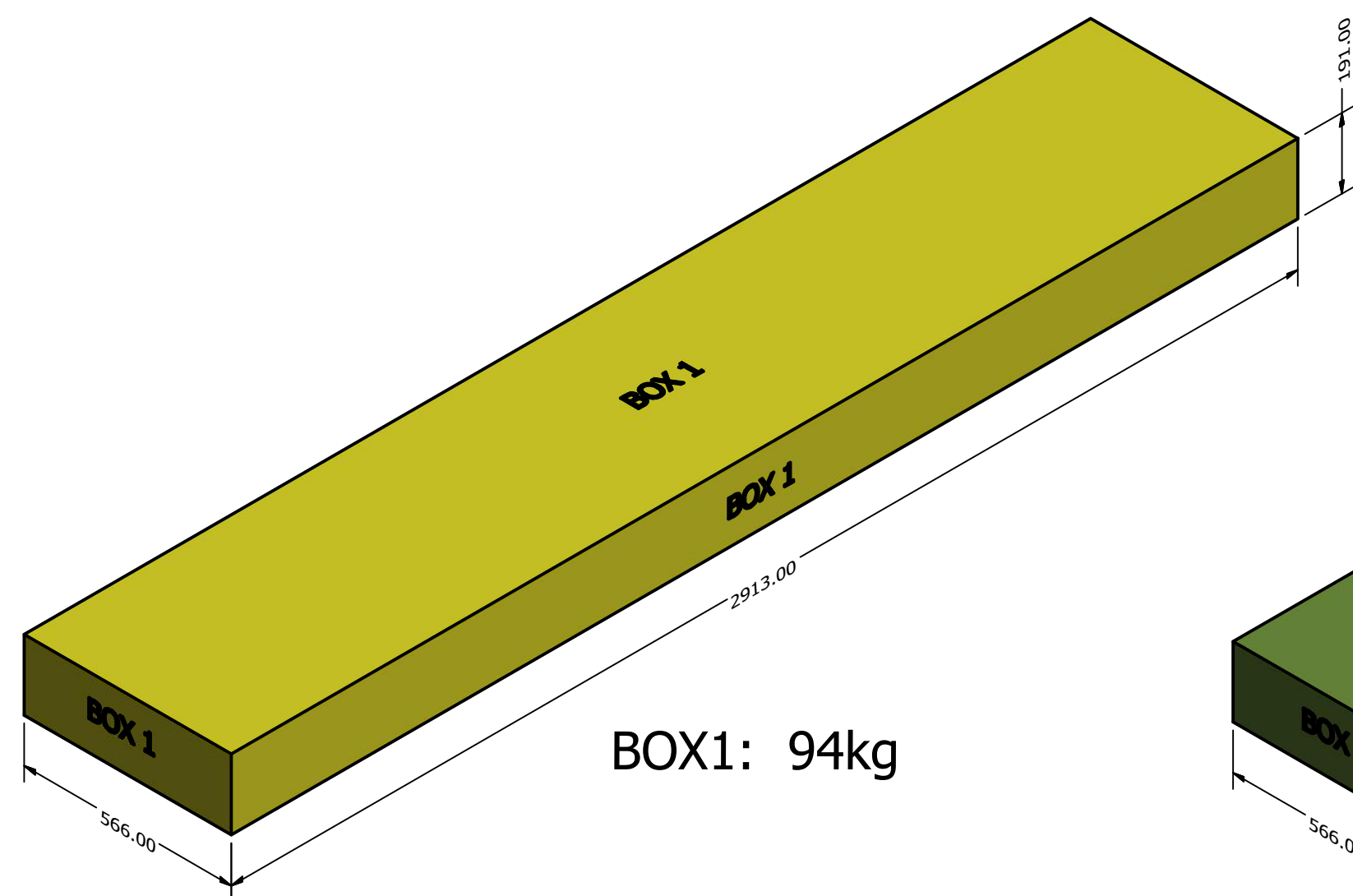

BOX1: 94kg

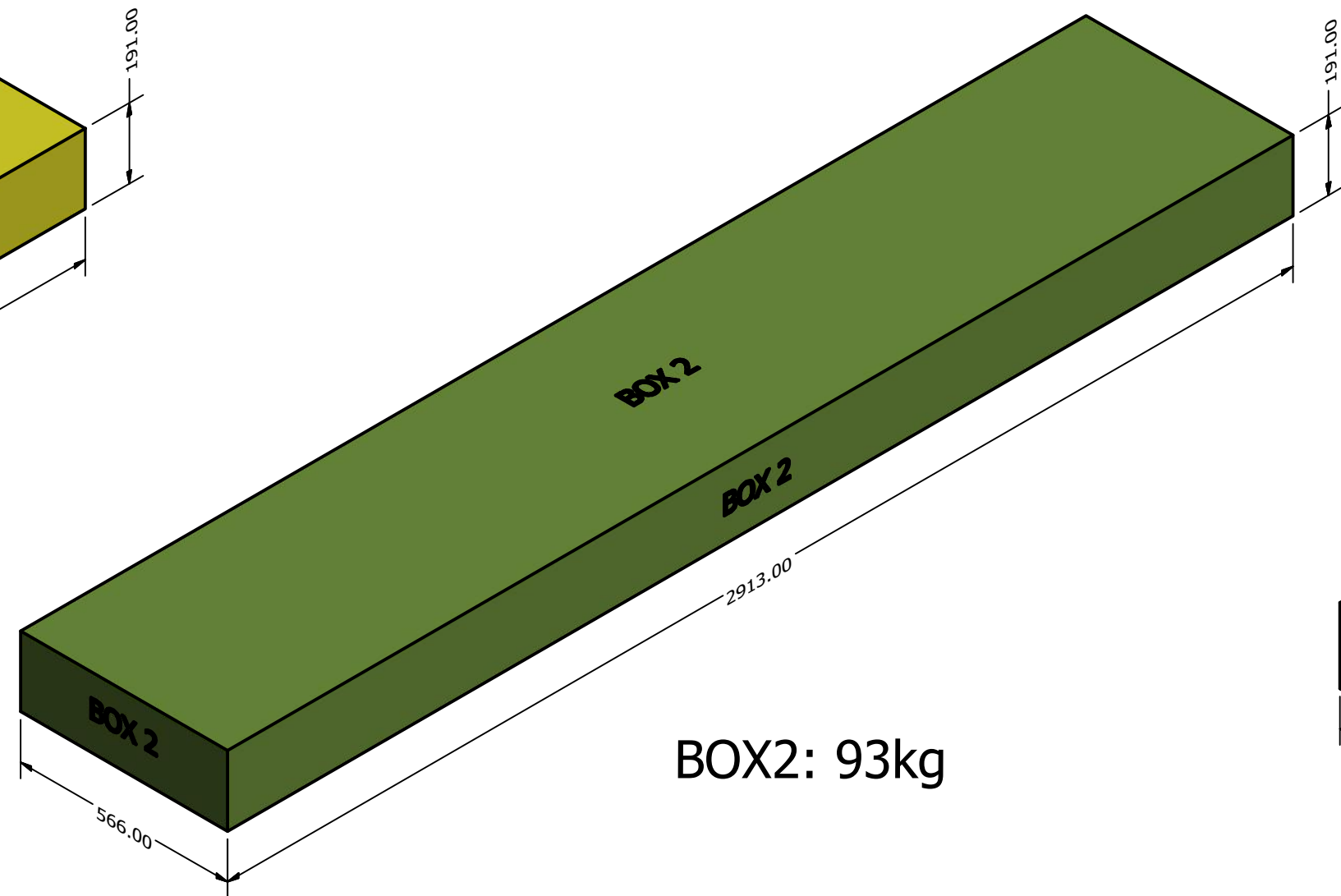

BOX2: 93kg

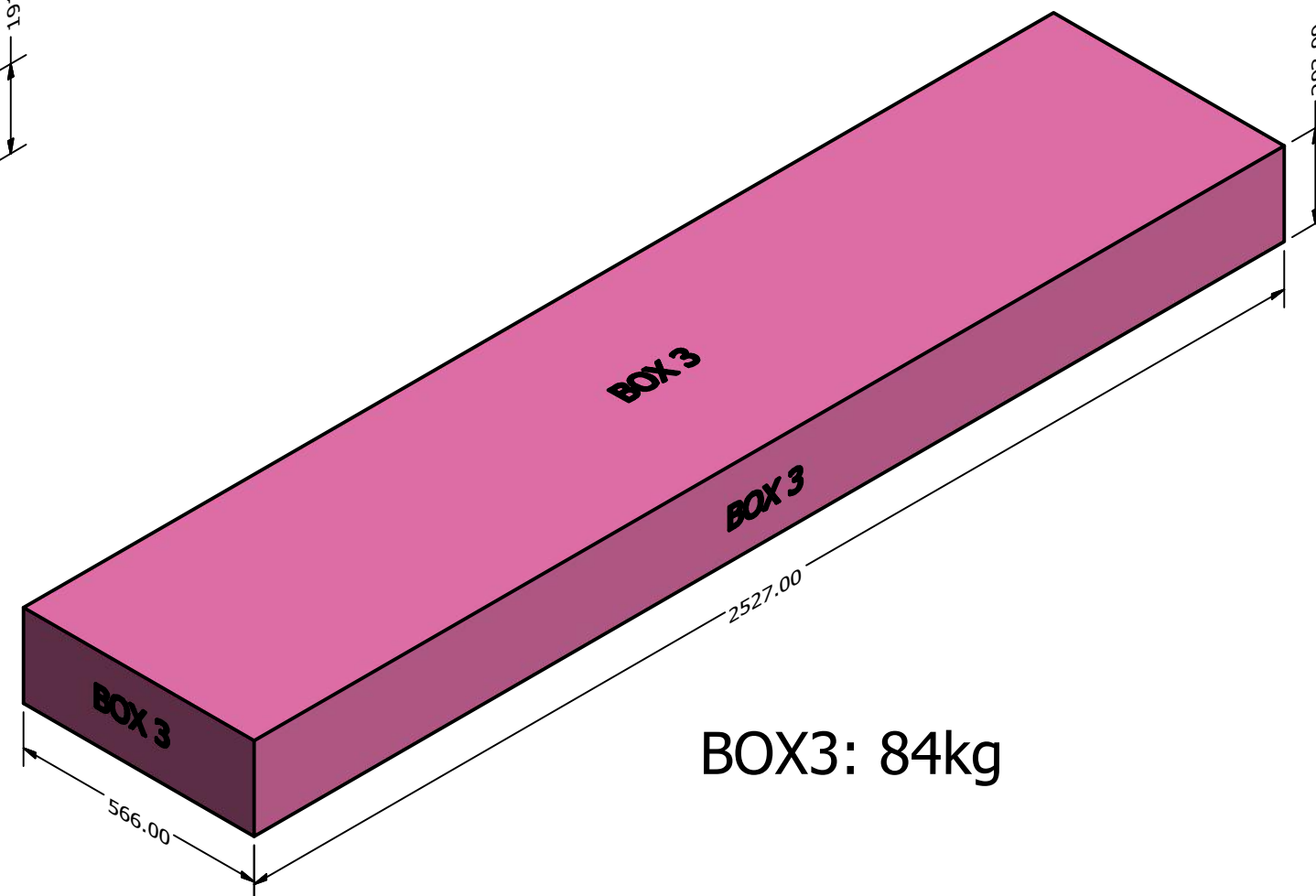

BOX3: 84kg

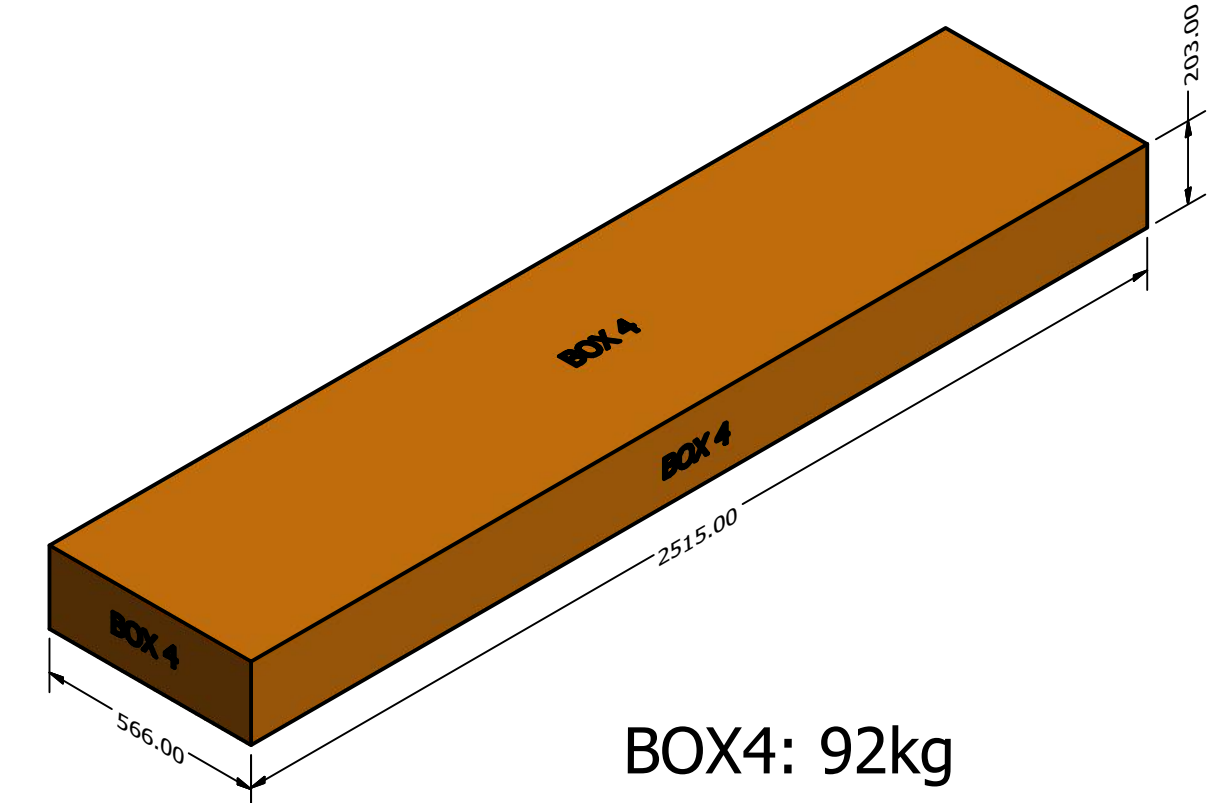

BOX4: 92kg

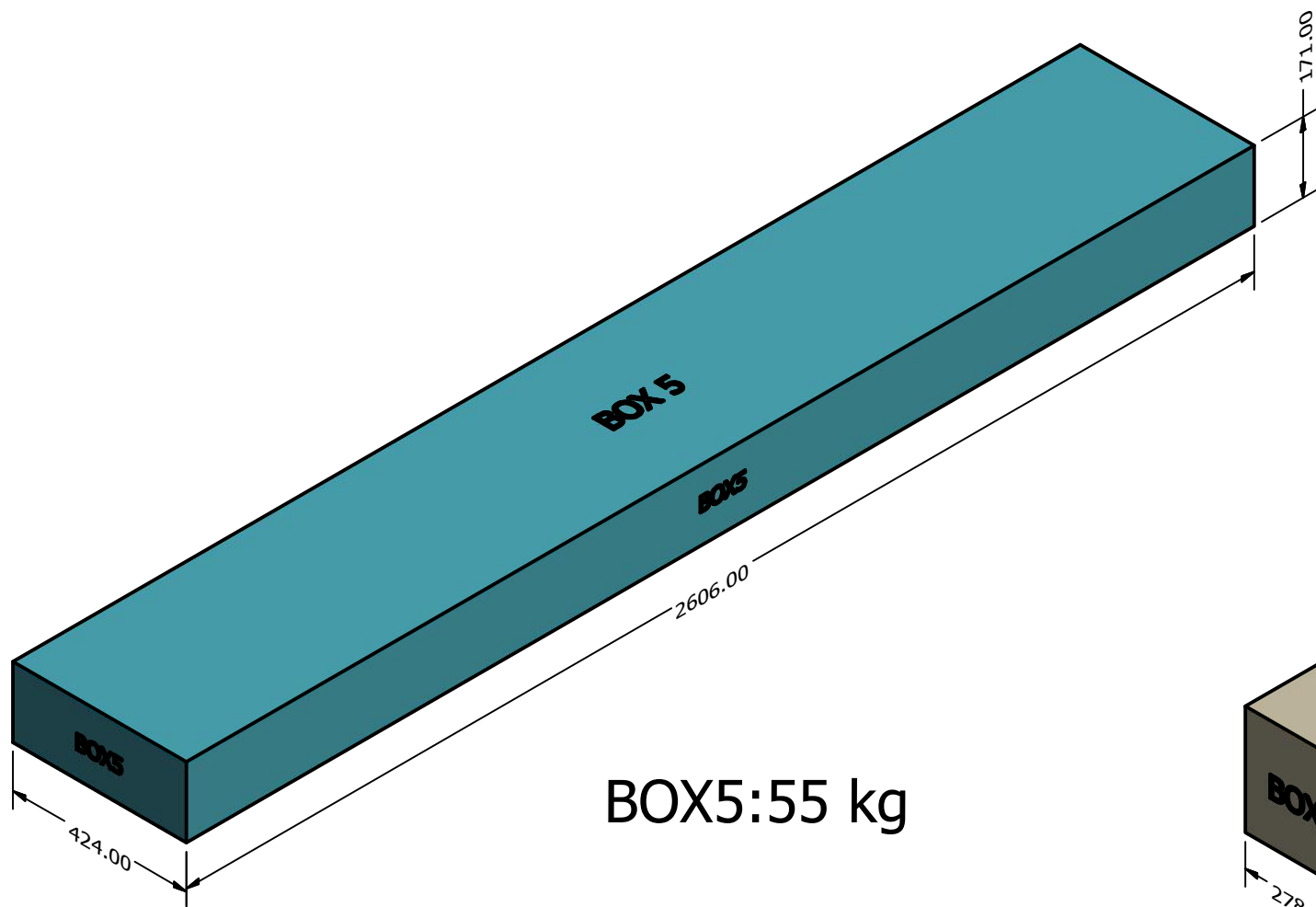

BOX5:55 kg

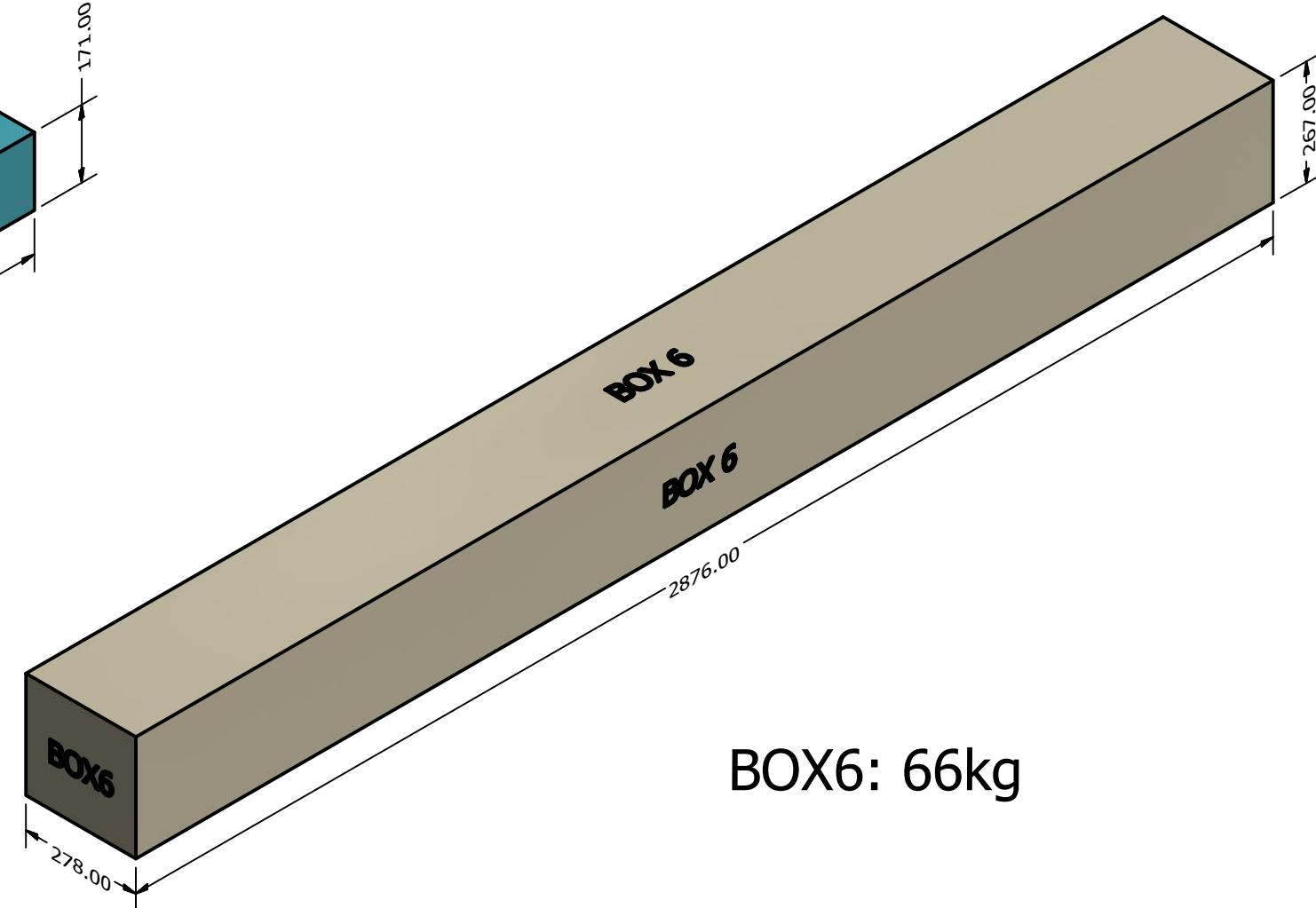

BOX6: 66kg

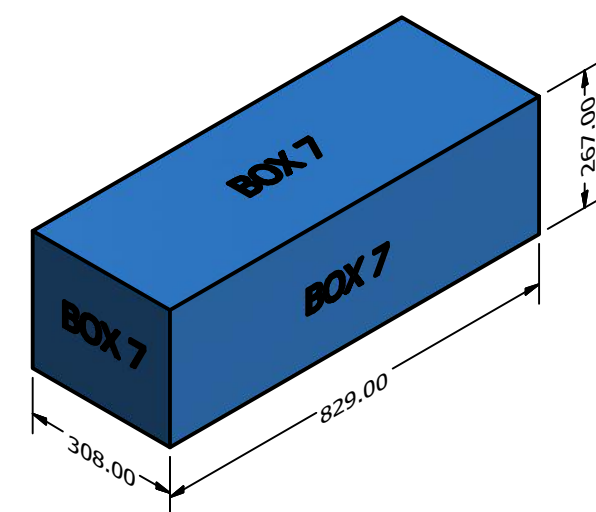

BOX7: 18 kg

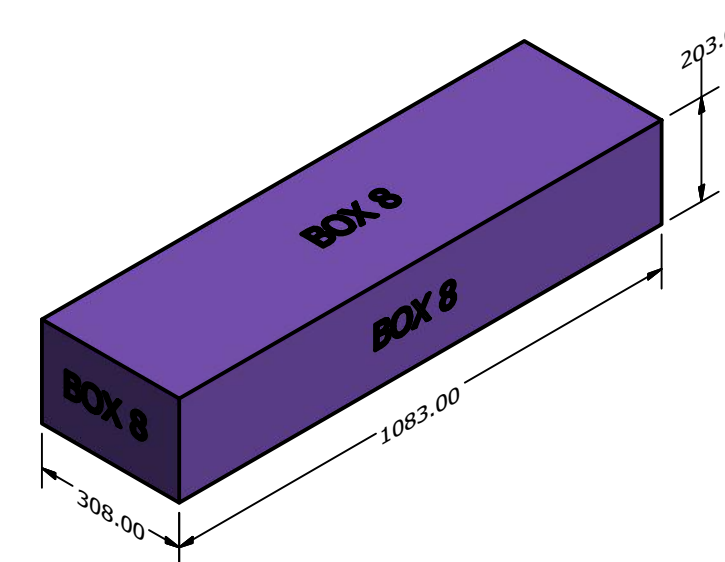

BOX8: 32kg

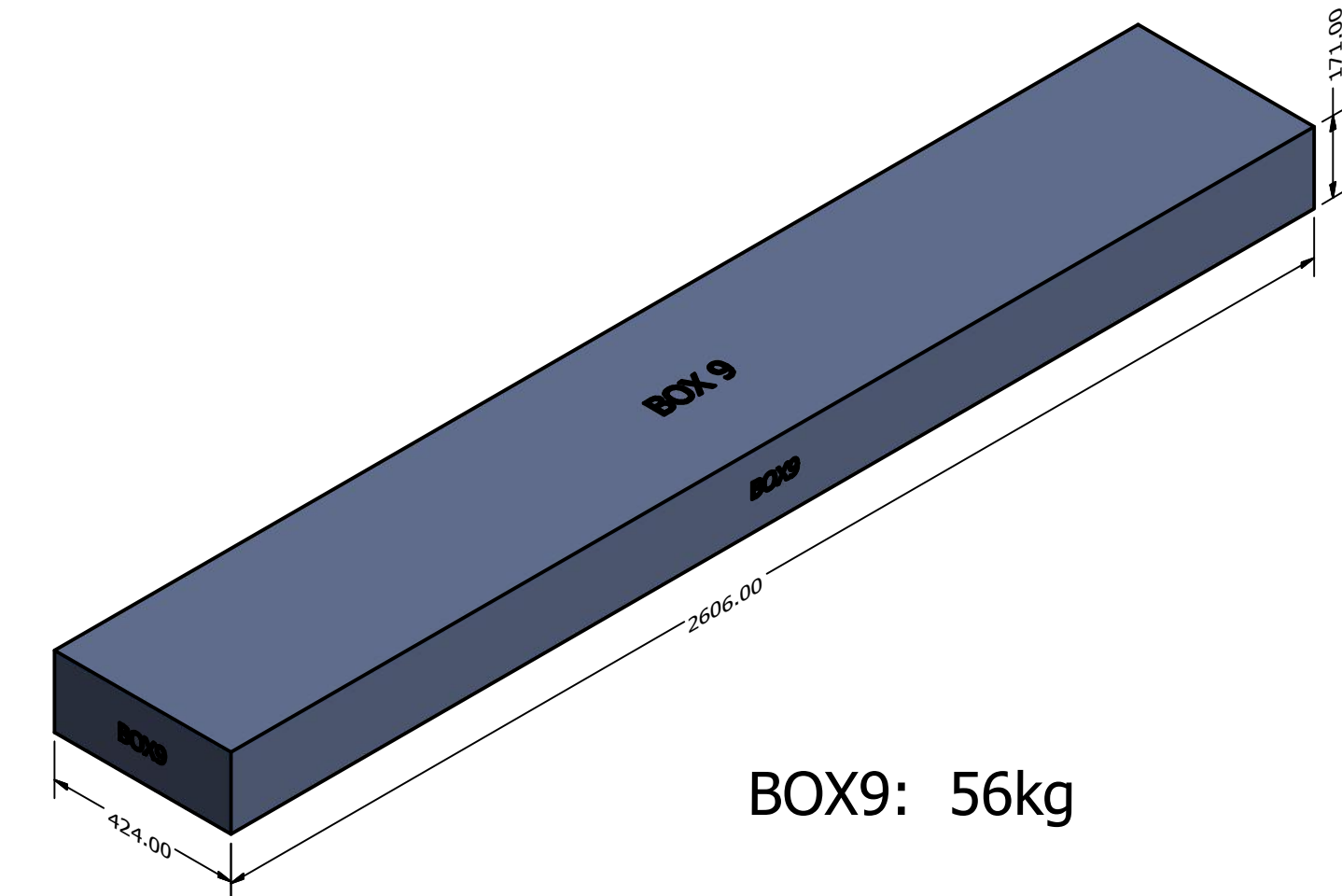

BOX9: 56kg

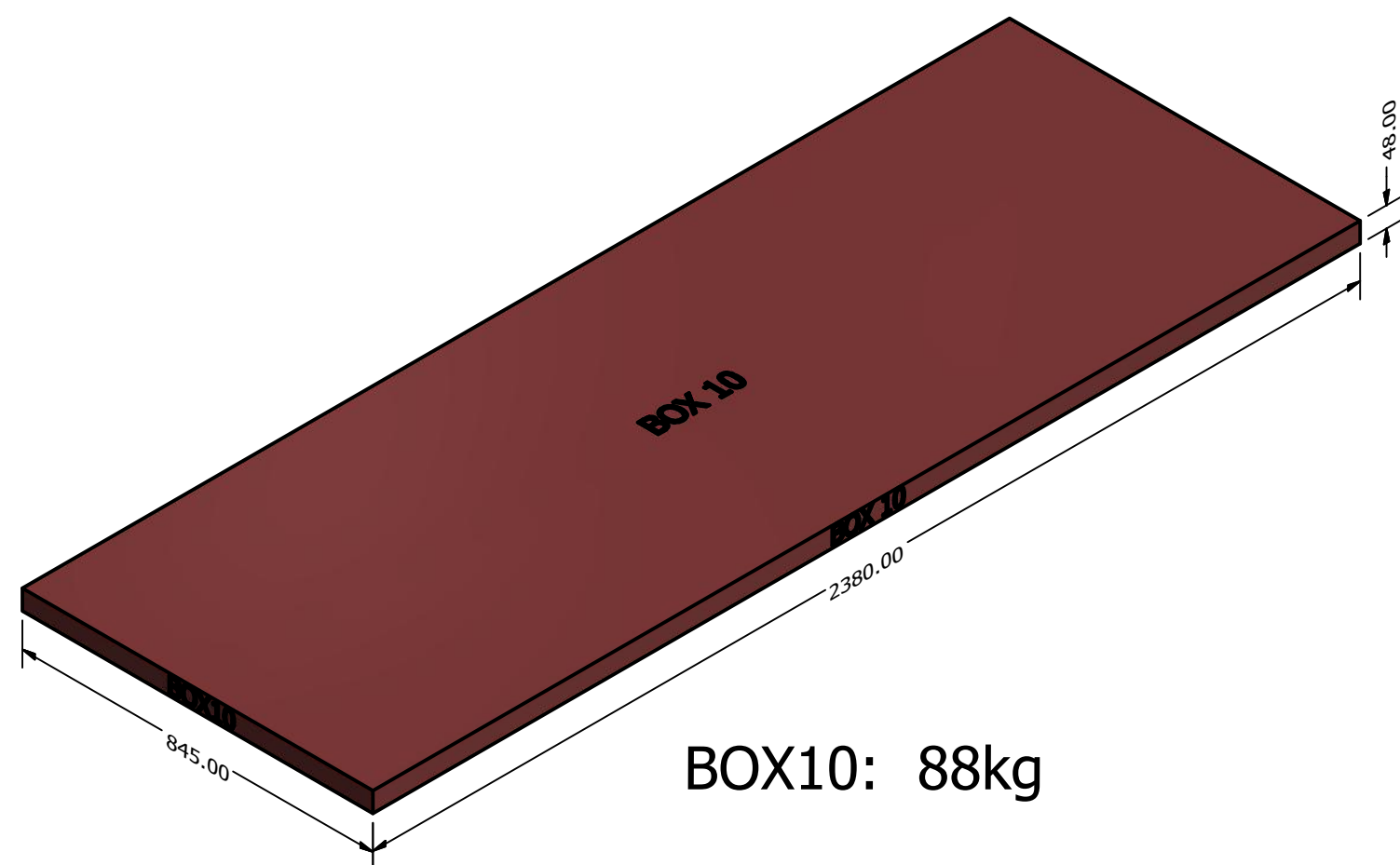

BOX10: 88kg

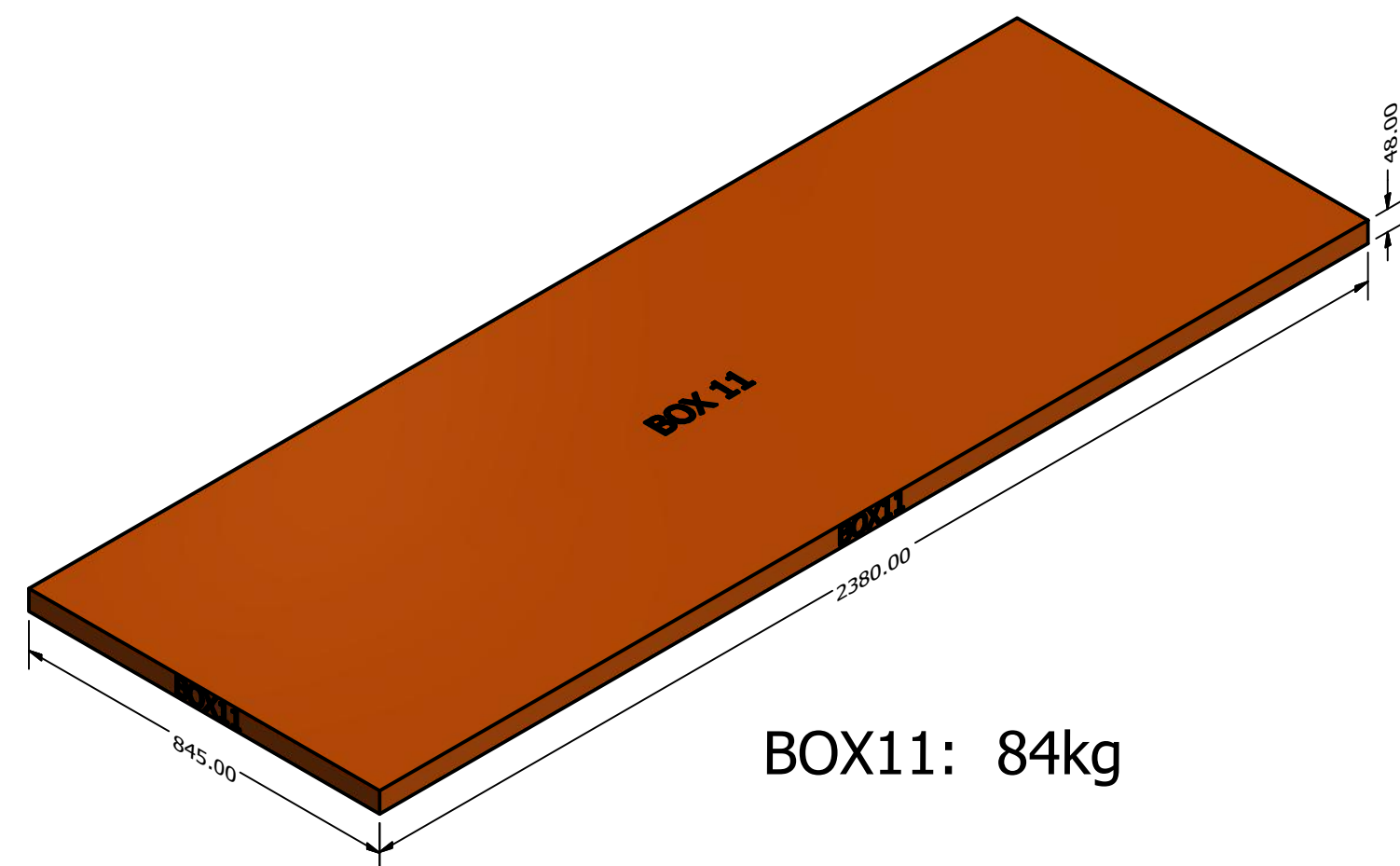

BOX11: 84kg

DRAWN Rudy		TITLE		
CHECKED				
QA		DWG NO BOXES		
MFG				
APPROVED		REV		
		SCALE	1 / 12	SHEET 1 OF 1