

SUMNER DINING TABLE ASSEMBLY INSTRUCTIONS

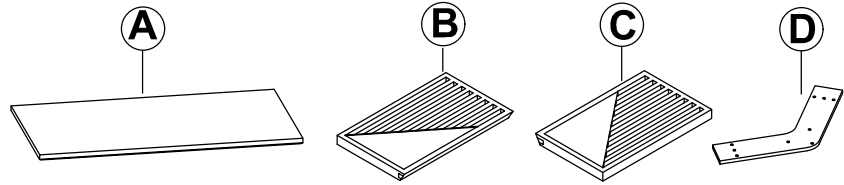

PARTS PACKING CONFIGURATIONS

- A. TABLE TOP 1 PC
- B. LEG B 2 PCS
- C. LEG C 2PCS
- D. CONNECTING PLATE 2PCS



HARDWARE KIT ENCLOSED IN CARTON

FULLY ASSEMBLED

No.	Description	Image	Quantity
1	ALLEN BOLT (5/16" x 1-1/4")		18 PCS
2	ALLEN BOLT (5/16" x 3/4")		8 PCS
3	LOCK WASHER (5/16")		18 PCS
4	FLAT WASHER (5/16")		18 PCS
5	ALLEN KEY(5/16")		1 PC
6	CONNECTING BRACKET		4 PCS

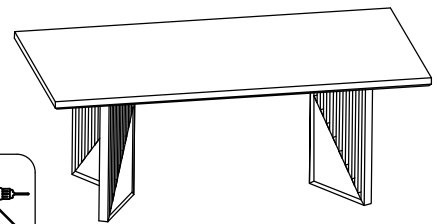

STEP 1:

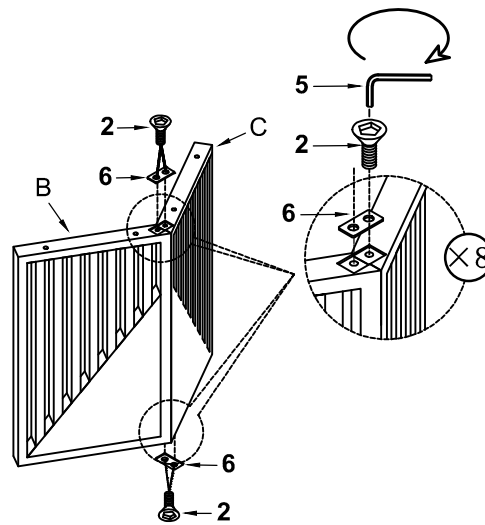

STEP 2:

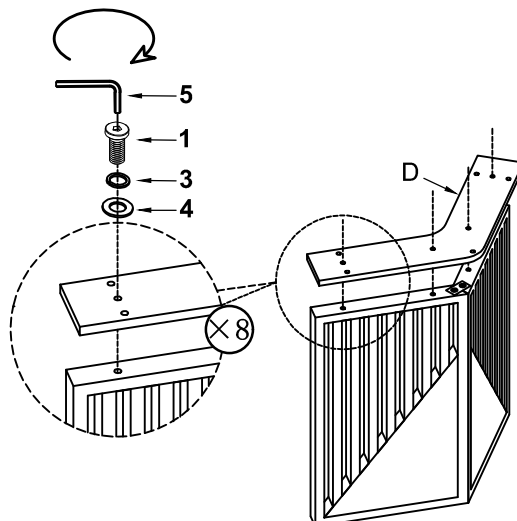

SUMNER DINING TABLE ASSEMBLY INSTRUCTIONS



STEP 3:

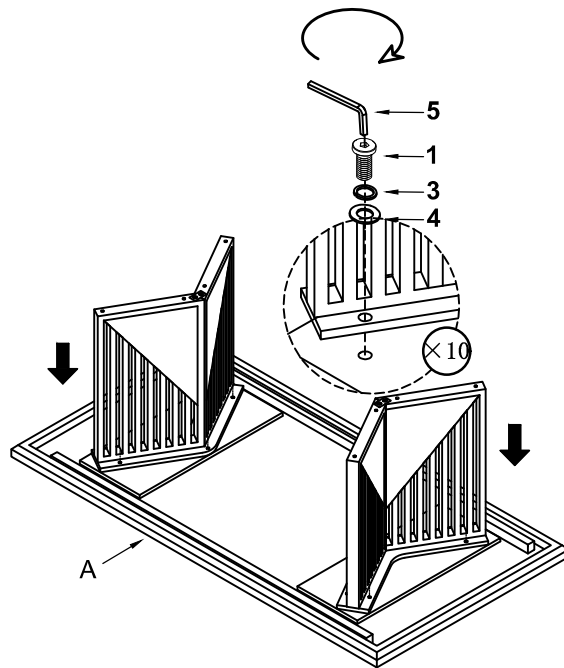

STEP 4:

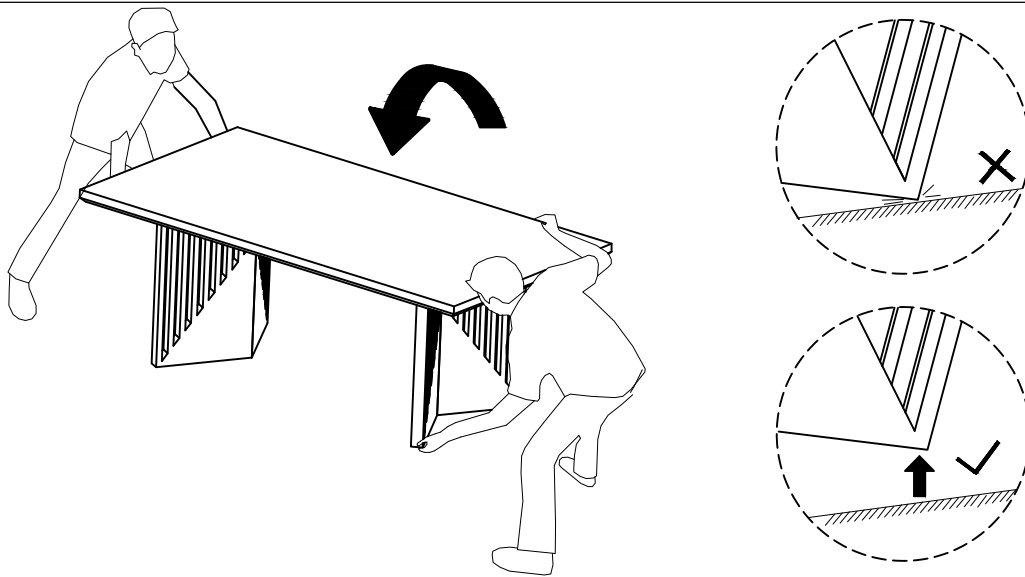

STEP 5:

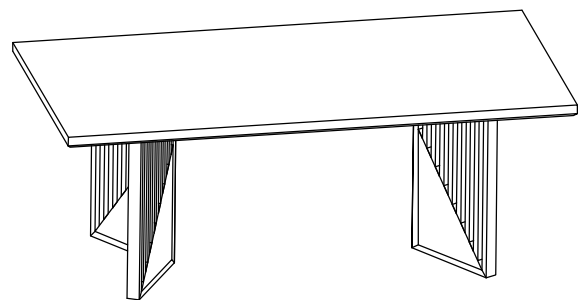
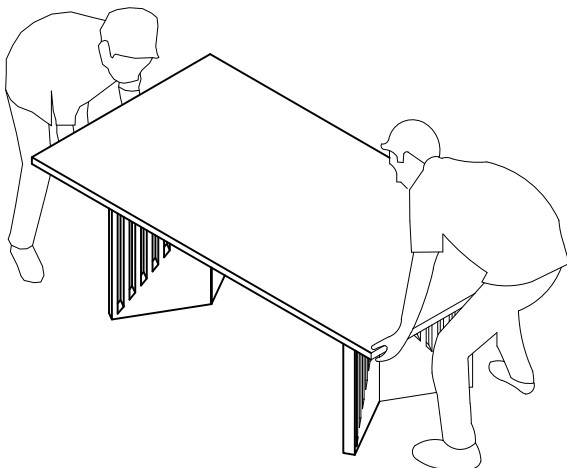

ASSEMBLY COMPLETE