

## Mustang Series

# LEAD FREE\*

## LFM115 (Globe) LFM1115 (Angle) Pressure Reducing Control Valve

### Schematic

- Throttles to reduce high upstream pressure to constant lower downstream pressure
- Reducing setpoint is adjustable

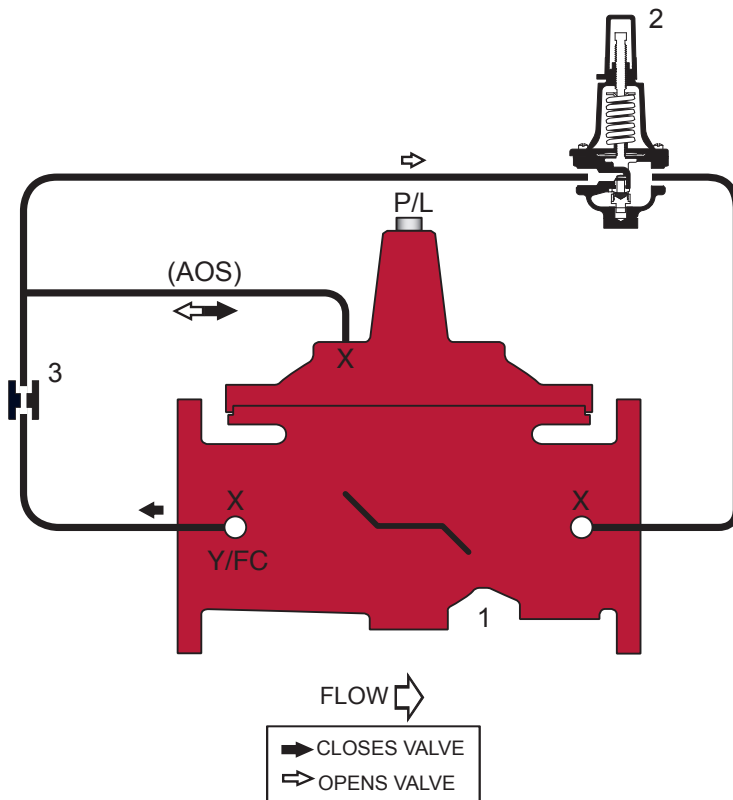

### Standard Components

- 1 – Main Valve (Single Chamber)
- 2 – Pressure Reducing Control
- 3 – Fixed Orifice

### Options & Accessories

- X – Isolation Cocks (2)
- FC – Flo-Clean Strainer (1)
- Y – Y-Strainer (Replaces Flo-Clean) (2)
- ACS – Adjustable Closing Speed (3)  
(Replaces Fixed Orifice)
- AOS – Adjustable Opening Speed (1)
- P – Position Indicator (3)
- L – Limit Switch (3)

(1) Standard 3" & Smaller

(2) Standard 4" & Larger

(3) Optional All Sizes

### Operations

The Watts ACV Pressure Reducing Control Valve is designed to automatically reduce a fluctuating higher upstream pressure to a constant lower downstream pressure regardless of varying flow rates. It is controlled by a normally open, pressure reducing pilot designed to: 1) Open (allowing fluid out of the main valve cover chamber) when downstream pressure is below the adjustable setpoint, and 2) Close (allowing fluid to fill the main valve cover chamber) when downstream pressure is above the adjustable setpoint. A decrease in downstream pressure causes the valve to modulate toward an open position, raising downstream pressure. An increase in downstream pressure causes the valve to modulate toward a closed position, lowering downstream pressure.

\*The wetted surface of this product contacted by consumable water contains less than 0.25% of lead by weight.

## Materials

- Body & Cover:** Ductile Iron ASTM A536
- Coating:** NSF Listed Fusion Bonded Epoxy Lined and Coated
- Trim:** 316 Stainless Steel
- Elastomers:** Buna-N (standard)  
EPDM  
Viton
- Stem, Nut & Spring:** Stainless Steel

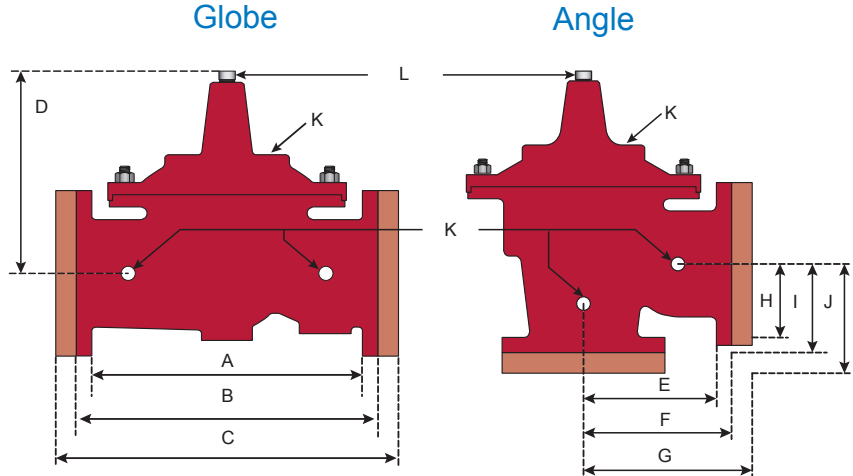

## Operating Pressure

- Threaded = 400 psi
- 150 Flanged = 250 psi
- 300 Flanged = 400 psi

## Operating Temperature

- Buna-N: 160 °F Maximum
- EPDM: 300 °F Maximum
- Viton: 250 °F Maximum

## Pilot System

- Reducing Control**
- 30-300 psi (Standard)
- 0-30 psi (Optional)

## Tubing & Fittings

- Copper / Brass (Standard)
- Stainless Steel (Optional)

## Dimensions

	A	B	C	D	E	F	G	H	I	J	K	L	
VALVE SIZE	GLOBE THRD.	GLOBE 150#	GLOBE 300#	COVER TO CENTER	ANGLE THRD.	ANGLE 150#	ANGLE 300#	ANGLE THRD.	ANGLE 150#	ANGLE 300#	PORT SIZE	PORT SIZE	SHIPPING WEIGHTS*
1-1/4	7-1/4	-	-	5-1/2	3-1/4	-	-	1-7/8	-	-	3/8	1/4	20
1-1/2	7-1/4	8-1/2	9	5-1/2	3-1/4	4	4-1/4	1-7/8	4	4-1/4	3/8	1/4	25
2	9-3/8	9-3/8	10	6-1/2	4-3/4	4-3/4	5	3-1/4	3-1/4	3-1/2	3/8	1/2	40
2-1/2	11	11	11-5/8	7-1/2	5-1/2	5-1/2	5-7/8	4	4	4-5/16	1/2	1/2	65
3	12-1/2	12	13-1/4	8-1/4	6-1/4	6	6-3/8	4-1/2	4	4-3/8	1/2	1/2	95
4	-	15	15-5/8	10-5/8	-	7-1/2	7-7/8	-	5	5-5/16	3/4	3/4	190
6	-	20	21	13-3/8	-	10	10-1/2	-	6	6-1/2	3/4	3/4	320
8	-	25-3/8	26-3/8	16	-	12-3/4	13-1/4	-	8	8-1/2	1	1	650
10	-	29-3/4	31-1/8	17-1/8	-	14-7/8	15-9/16	-	8-5/8	9-5/16	1	1	940
12	-	34	35-1/2	20-7/8	-	17	17-3/4	-	13-3/4	14-1/2	1	1-1/4	1500
14	-	39	40-1/2	24-1/4	-	19-1/2	20-1/4	-	14-7/8	15-5/8	1	1-1/2	1675
16	-	41-3/8	43-1/2	25	-	20-13/16	21-5/8	-	15-11/16	16-1/2	1	2	3100

\*Estimated in lbs.

## Valve Cover Chamber Capacity

Valve Size (in)	1-1/4	1-1/2	2	2-1/2	3	4	6	8	10	12	14	16
fl.oz.	4	4	4	10	10	22	70	-	-	-	-	-
U.S. Gal	-	-	-	-	-	-	-	1-1/4	2-1/2	4	6-1/2	9-1/2

## Valve Travel

Valve Size (in)	1-1/4	1-1/2	2	2-1/2	3	4	6	8	10	12	14	16
Travel (in)	3/8	3/8	1/2	5/8	3/4	1	1-1/2	2	2-1/2	3	3-1/2	4

**Sizing**

Size (in)	1-1/4	1-1/2	2	2-1/2	3	4	6	8	10	12	14	16
Maximum Continuous (GPM)	95	130	210	300	485	800	1850	3100	5000	7000	8500	11100
Maximum Intermittent (GPM)	119	161	265	390	590	1000	2300	4000	6250	8900	10800	14100
Minimum Continuous (GPM)												

Maximum continuous flow based on velocity of 20 ft. per second.  
 Maximum intermittent flow based on velocity of 25 ft. per second.  
 Minimum continuous flow based on velocity of 1 ft. per second.

**NOTE:** The above chart is a suggested guide. Inlet pressure, outlet pressure, minimum, normal and maximum flow rates should be considered for specific valve sizing. Contact Watts ACV for details.

**Cavitation Chart**

After selecting the valve size, locate inlet and outlet pressures on this chart. If the intersection point falls in the shaded area, cavitation can occur. Operation of valves continually in the cavitation zone should be avoided. Consult Watts ACV for alternatives.

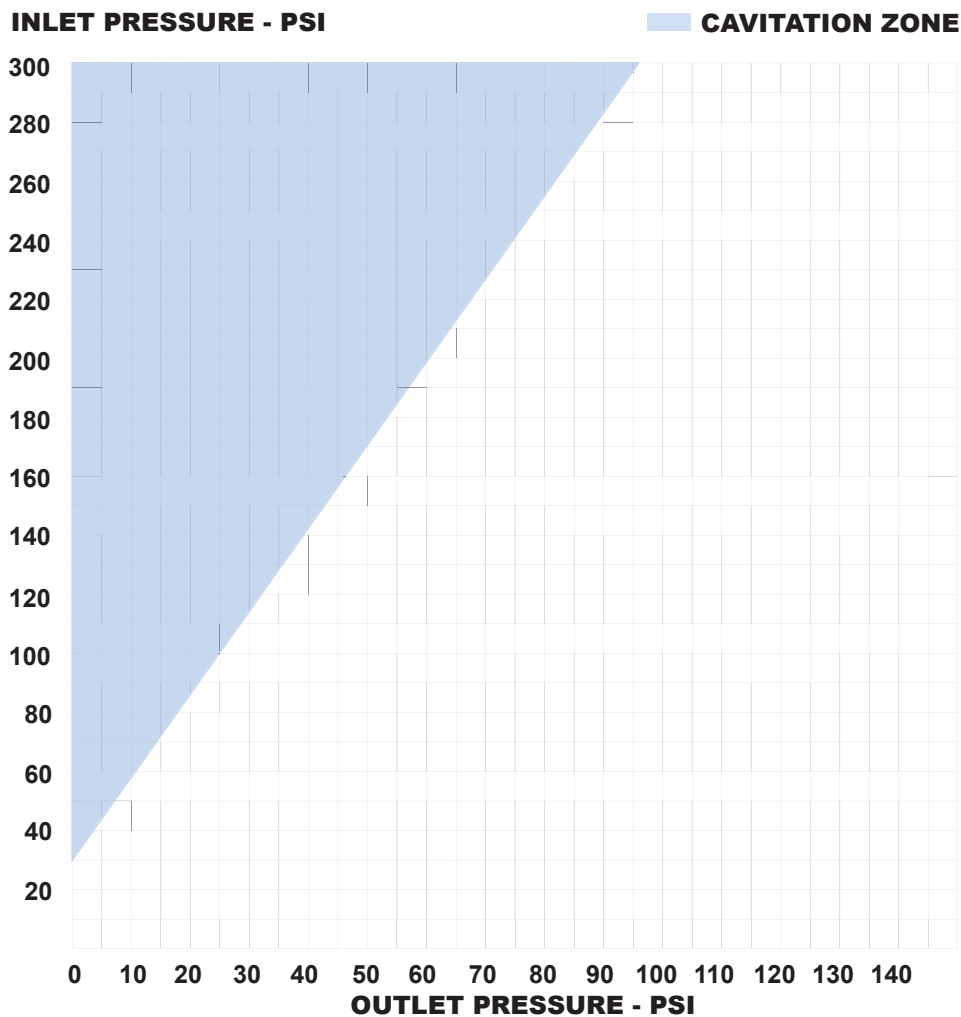

Cross-Sectional Detail

Main Valve

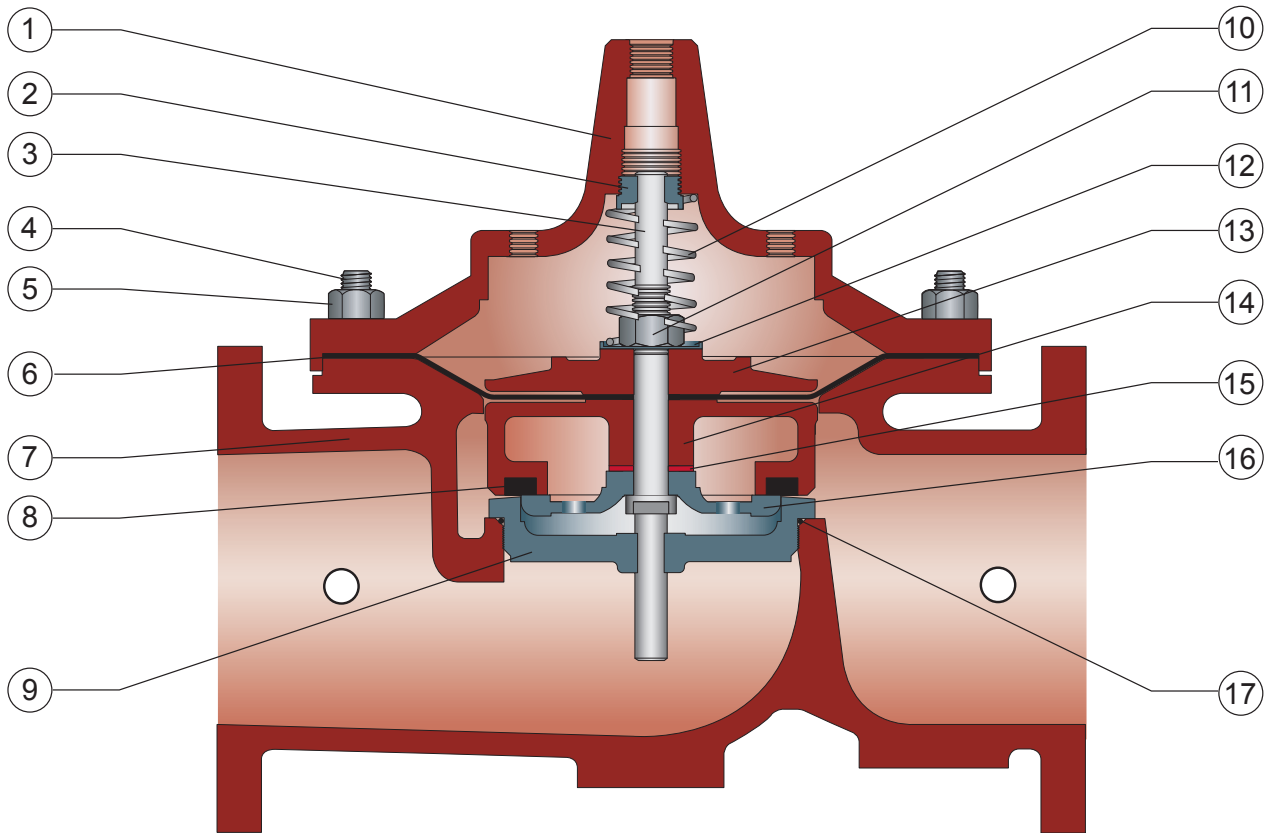

ITEM	DESCRIPTION	MATERIAL
1	Cover	ASTM A536 65-45-12 Epoxy Coated Ductile Iron
2	Cover Bearing	ASTM A276 304 Stainless Steel
3	Shaft / Stem	ASTM A276 304 Stainless Steel
4	Stud	ASTM A570 Gr.33 Zinc Plated Steel
5	Cover Nut	ASTM A570 Gr.33 Zinc Plated Steel
6	<b>Diaphragm*</b>	Buna-N (Nitrile)
7	Body	ASTM A536 65-45-12 Epoxy Coated Ductile Iron
8	<b>Seat Disc*</b>	Buna-N (Nitrile)
9	Seat Ring	ASTM A743 CF8M (316) Stainless Steel
10	Spring	ASTM A276 302 Stainless Steel
11	Stem Nut	ASTM A276 304 Stainless Steel
12	Spring Washer	ASTM A276 304 Stainless Steel
13	Diaphragm Washer	ASTM A536 65-45-12 Epoxy Coated Ductile Iron
14	Disc Retainer	ASTM A536 65-45-12 Epoxy Coated Ductile Iron
15	<b>Spacer Washer*</b>	Fiber*
16	Disc Guide	ASTM A743 CF8M (316) Stainless Steel
17	<b>Seat Gasket*</b>	Buna-N (Nitrile)

\* Contained in Main Valve Repair Kit

**Controls and Accessories**

*Model LFCP-15*

*Pressure Reducing Pilot*

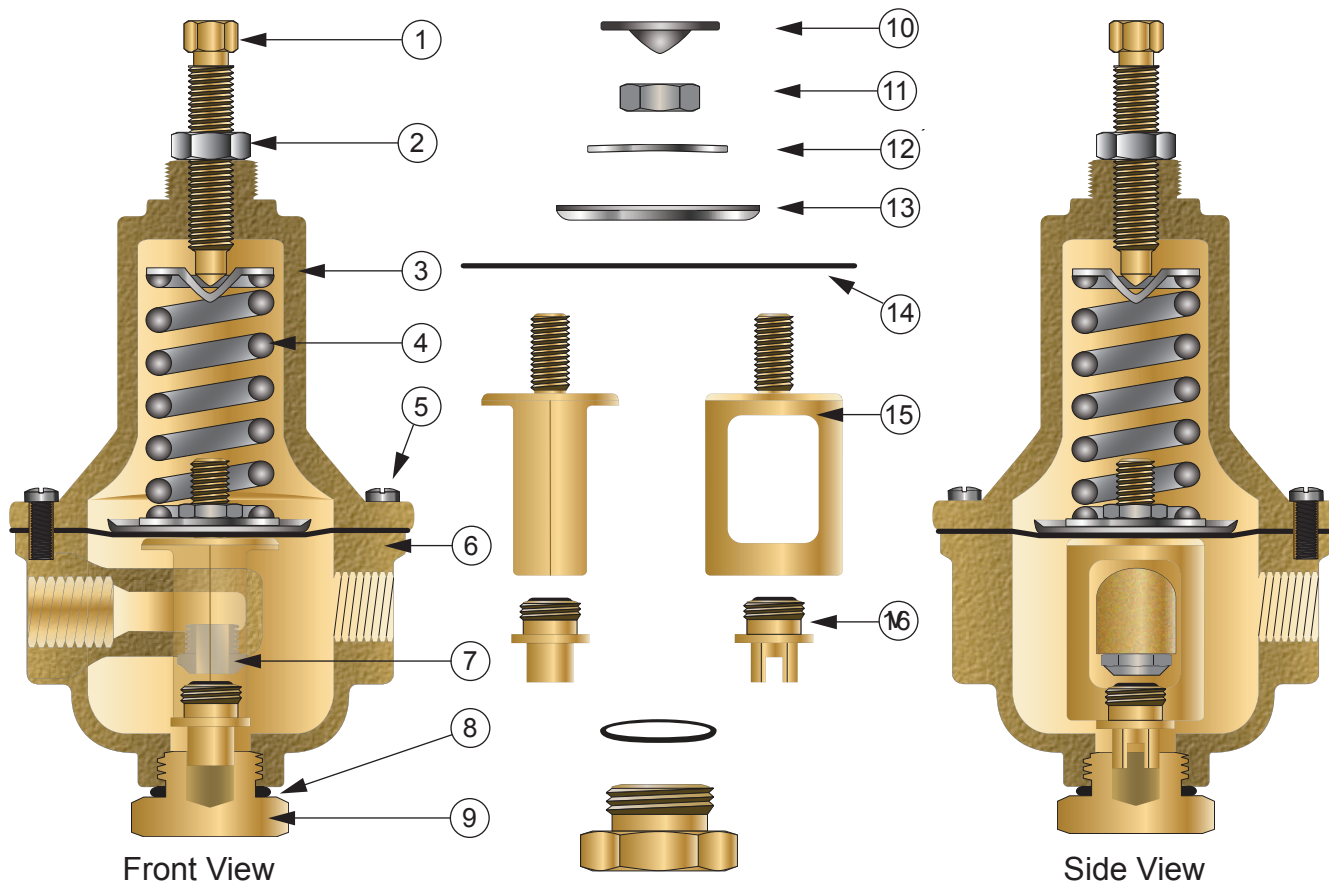

ITEM NUMBER	DESCRIPTION
1	Adjusting Screw
2	Jam Nut
3	Spring Housing
4	Spring
5	Cap Screw
6	Body
7	Seat
8	O-Ring*
9	Bottom Cap
10	Spring Guide

ITEM NUMBER	DESCRIPTION
11	Nut
12	Belleville Washer
13	Diaphragm Washer
14	Diaphragm *
15	Yoke
16	Disc and Retainer Assembly*

*\* Included in Repair Kit*

## Installations

- Prior to installation, flush line to remove debris.
- Install valve horizontally “in line” (cover facing up), so flow arrow matches flow through the line. **Avoid installing valves 6" and larger vertically.** Consult factory **prior** to ordering if installation is other than described.
- Install inlet and outlet isolation valves.

### NOTICE

When using butterfly valves, insure disc does not contact control valve. Damage or improper valve seating may occur.

- Provide adequate clearance for valve servicing and maintenance.
- Install pressure gauges to monitor valve inlet and outlet pressure.
- If installation is subjected to very low flow or potentially static conditions, it is recommended a pressure relief valve (1/2" minimum) be installed downstream of the Pressure Reducing Valve for additional system protection.

## Start-Up

Proper Automatic Control Valve startup requires bringing the valve into service in a controlled manner. All adjustments to control pilots and speed controls should be made slowly, allowing the valve to respond and the system to stabilize.

### NOTICE

**Control Valves should be set-up in a dynamic (flowing) condition for proper start-up. Provisions for flow must be made to insure proper settings.**

1. Close upstream and downstream valves to isolate the valve from line pressure. Release spring tension on Pressure Reducing Control by turning adjustment screw out (counterclockwise), decreasing setpoint. Open all Isolation Ball Valves, if so equipped. If valve is fitted with adjustable speed controls, turn needle(s) in (clockwise) until seated, and return out (counterclockwise) 11/2 to 21/2 turns. These are approximate settings, and should be fine tuned to suit system requirements after pressure adjustments have been made.
2. Slowly open upstream isolation valve to allow controlled filling of the valve. Vent entrapped air by carefully loosening control tubing or pipe plug at the highest point possible. If valve is equipped with a Position Indicator, open Air Bleed Petcock to vent air. Water will be milky in appearance and will begin to clear as air is vented. Carefully loosen enough cover screws on control pilot(s) to vent entrapped air. Retighten when water vents clearly.
3. **Setting Reducing Control:** Slowly open downstream isolation valve. Gradually turn adjustment screw on the Pressure Reducing Control in (clockwise) to raise downstream pressure. Allow valve and system to stabilize. Observe inlet and outlet pressure gauges. Continue to adjust as needed, pausing approximately every 11/2 turns, allowing valve and system to stabilize. Turning adjustment screw clockwise raises outlet pressure. Turning adjustment screw counterclockwise lowers outlet pressure. When desired downstream pressure is reached, tighten locknut on adjustment screw.
4. Fine tune Speed Controls to suit system requirements. Adjust Closing Speed Control (if equipped) clockwise for slower closure, and counterclockwise for faster closure. Adjust Opening Speed Control (if equipped) clockwise for slower opening, and counterclockwise for faster opening.

## Specifications

The Lead Free\* Pressure Reducing Control Valve shall be a pilot operated diaphragm valve designed to automatically reduce a fluctuating higher upstream pressure to a constant lower downstream pressure regardless of varying flow rates.

The main valve shall be a hydraulically operated, single diaphragm actuated, globe or angle pattern valve. Y-pattern valves shall not be permitted. The valve shall contain a disc and diaphragm assembly that forms a sealed chamber below the valve cover, separating operating pressure from line pressure. The diaphragm shall be constructed of nylon reinforced Buna-N, and shall not seal directly against the valve seat and shall be fully supported by the valve body and cover. Rolling diaphragm construction will not be allowed and there shall be no pistons operating the main valve or any pilot controls.

The main valve body and cover shall be Ductile Iron ASTM A536, and all internal cast components shall be Ductile Iron or CF8M (316) Stainless Steel. All Ductile Iron components, including the body and cover, shall be lined and coated with an NSF 61 Certified Epoxy Coating applied by the electrostatic heat fusion process. All main valve trim and throttling components (cover bearing, valve seat and disc guide) shall be Stainless Steel. The valve body and cover must be machined with a 360-degree locating lip to assure proper alignment.

The disc and diaphragm assembly shall contain a Buna-N synthetic rubber disc with a rectangular cross-section that is securely retained on 3-1/2 sides by a disc retainer and disc guide. Diaphragm assemblies utilizing bolts or cap screws for component retention will not be permitted.

The exposed portion of the seat disc shall contact the valve seat and seal drip-tight. The disc and diaphragm assembly must be guided by two separate bearings, one installed in the valve cover and one concentrically located within the valve seat, to avoid deflection and assure positive disc-to-seat contact. Center guided valves will not be permitted. All necessary repairs shall be made from the top of the valve while the body remains in line.

Pilot control systems for valves 3" and smaller shall contain a Flow Clean Strainer, Fixed Orifice Closing Speed, Adjustable Opening Speed Control and Pressure Reducing Pilot. Pilot control systems for valves 4" and larger shall contain an external Y-Strainer, Fixed Orifice Closing Speed, Pressure Reducing Pilot and Isolation Ball Valves on all body connections. All pilot control systems shall utilize copper tubing and brass fittings regardless of valve size. The adjustment range of the pressure reducing pilot shall be 30-300 psi.

The valve shall be Watts ACV Model LFM115 (Globe) or LFM1115 (Angle) pattern Pressure Reducing Control Valve.

## Other Watts ACV Pressure Reducing Control Valves

LFM115-3 / LFM1115-3	Pressure Reducing Valve with Hydraulic Check Feature
LFM115-7 / LFM1115-7	Pressure Reducing Valve with Downstream Surge Control Feature
LFM115-74 / LFM1115-74	Pressure Reducing Valve with Low Flow By-Pass

\*The wetted surface of this product contacted by consumable water contains less than 0.25% of lead by weight.