



TACOMA FALLS SWING SET

MANUFACTURED BY:
Backyard Discovery
3305 Airport Drive
Pittsburg, KS 66762
800-856-4445

Model # 1902022B | Owner's Manual & Assembly Instructions



WARNING

Adult Assembly Required.

The assembly manual must be retained since it contains important information

Not suitable for children under two years due to sharp points and small parts.

FOR DOMESTIC USE ONLY. INTENDED FOR OUTDOOR USE.

CAN ICES-003 (B)/NMB-003(B)



INSTALLATION SERVICES AVAILABLE!*

Need a helping hand?

Let our team of professionals handle the installation for you!

GOCONFIGURE
888-888-5424

*Installation services are only available to U.S. customers.

average 2 person assembly time

INTERMEDIATE
12
HOURS

average tube slide assembly time

INTERMEDIATE
3
HOURS

assembly time may vary based on skill level

Before you begin

FOR QUICK & EASY ASSEMBLY

FIND 3D INSTRUCTIONS FOR THIS PRODUCT IN

BILT.

DOWNLOAD THE FREE APP



For the most up to date assembly manual, to register your set, or to order replacement parts please visit www.backyarddiscovery.com

SAVE THIS ASSEMBLY MANUAL FOR FUTURE REFERENCE IN THE EVENT THAT YOU NEED TO ORDER REPLACEMENT PARTS.

Para obtener instrucciones en español, visite www.backyarddiscovery.com



GOCONFIGURE
Putting it all together for you

INSTALLATION SERVICES AVAILABLE!*

Need a helping hand?

Let our team of professionals handle the installation for you!

GOCONFIGURE
888-888-5424

**Installation services are only available
to U.S. customers.*

With Go Configure, we bring you 18 years of experience right to your doorstep. We service a wide array of indoor and outdoor recreation products that most consumers don't have the time or ability to deliver & install themselves.

We do the heavy lifting, so you don't have to!

- 18+ Years of Experience Servicing Big Box Retailers and Direct Consumers
- Highly Skilled, Specialized, Courteous, Professional Service Technicians
- Over 140,000 Installations Annually
- White Glove Service

- Satisfaction Guarantee
- Flexible Appointments, including weekends
- Coverage across the nation

Visit www.goconfigure.com for more info!

**Installation services are only available to U.S. customers.*



The store where you made your purchase does not stock parts for this item. If you have assembly questions or you are missing or have damaged parts, please call

1-800-856-4445

you can also visit www.backyarddiscovery.com
or e-mail customerservice@backyarddiscovery.com

Please have the following information ready when you make your call:

- Model Number of the product located on the front of the assembly manual
 - The item description and number from the parts list from the manual that was included in your box
-
- Read entire assembly manual, paying special attention to the important tips and safety information.
 - To ensure there are no missing pieces do a complete inventory by first separating and identifying all parts.
 - Make sure to check packing material for small parts that may have fallen out during shipment.
 - Structures are not intended for public use. The Company does not warranty any of its residential structures subjected to commercial use.
 - This manual contains helpful information concerning assembly preparation, installation procedure and required maintenance.
 - Always keep safety in mind as your structure is being built.
 - Keep these instructions for future reference.



Please read entire booklet completely before beginning the assembly process

Please retain these instructions and your receipt for future reference. Keep them in a safe place where you can refer to them as needed. In order to provide you with the most efficient service, it is required that you provide us with the part numbers when ordering parts.

For Your Records:

Please take time and fill out the information below. This information will be needed for warranty issues.

Where Purchased: _____
 Date of Purchase: _____
 Installation Date: _____
 Installed by: _____
 Tracking Number: _____

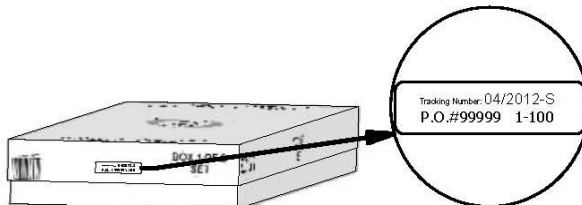
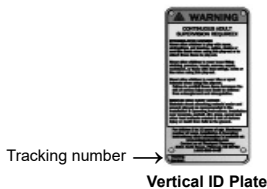

Tracking Number Reference Label

Tracking ID number on the carton and on the bottom of the vertical ID plate are included for tracking purposes associated with warranty claims.

This Limited Warranty by Backyard Discovery applies to products manufactured under the Backyard Discovery brand or its other brands including but not limited to Backyard Botanical, Adventure Playsets, and Leisure Time Products.

Backyard Discovery warrants that this product is free from defect in materials and workmanship for a period of one (1) year from the original date of purchase. This one (1) year warranty covers all parts including wood, hardware, and accessories. All wood carries a five (5) year pro-rated warranty against rot and decay. Refer to the schedule below for charges associated with replacement of parts under this Limited Warranty. In addition, Backyard Discovery will replace any parts within the first 30 days from date of purchase found to be missing from or damaged in the original packaging.

This warranty applies to the original owner and registrant and is non-transferable. Regular maintenance is required to assure maximum life and performance of this product. Failure by the owner to maintain the product according to the maintenance requirements may void this warranty. Maintenance guidelines are provided in the Owner's Manual.

This Limited Warranty does not cover:

- Installation
- Labor for any inspection
- Labor for replacement of any defective item(s)
- Incidental or consequential damages
- Cosmetic defects which do not affect performance or integrity of a part or the entire product
- Vandalism, improper use, failure due to loading or use beyond the capacities stated in the applicable Assembly Manual.
- Acts of nature including but not limited to wind, storms, hail, floods, excessive water exposure
- Improper installation including but not limited to installation on uneven, unlevel, or soft ground
- Minor twisting, warping, checking, or any other natural occurring properties of wood that do not affect performance or integrity

Backyard Discovery products have been designed for safety and quality. Any modifications made to the original product could damage the structural integrity of the unit leading to failure and possible injury. Modification voids any and all warranties and Backyard Discovery assumes no liability for any modified products or consequences resulting from failure of a modified product.

This product is warranted for RESIDENTIAL USE ONLY. Under no circumstance should a Backyard Discovery product be used in public settings. Such use may lead to product failure and potential injury. Any and all public use will void this warranty. Backyard Discovery disclaims all other representations and warranties of any kind, express or implied.

Pro Rated Part Replacement Schedule

| <u>Product Age</u> | <u>Customer Pays</u> |
|---------------------------------|-----------------------|
| All Parts | |
| 0-30 days from date of purchase | \$0 and free shipping |
| 31 days to 1 year | \$0 + S&H |
| Wood Rot and Decay Only | |
| 1 year | \$0 and free shipping |
| 2 year | 20% + S&H |
| 3 year | 40% + S&H |
| 4 year | 60% + S&H |
| 5 year | 80% + S&H |
| Over 5 years | 100% + S&H |



NOTE:

Your Children's Safety Is Our #1 Concern!

Observe the following statements and warnings to reduce the likelihood of serious or fatal injury. Please review these safety rules regularly with your children.



WARNING: BURN HAZARD

- Pay special attention to plastic and metal surfaces as they may be hot enough to cause burns.
- Always check the temperature of the product before letting your children play on it.
- Remember that the product may cause burns if left in direct sunlight.
- Always be aware of the sun and weather conditions, and do not assume that the equipment is safe because the air temperature is not very high.

- Children **MUST NOT** use this playcenter until unit has been completely assembled and inspected by an adult to ensure set has been properly installed and anchored.
- Equipment is recommended for use by children 3 to 10 years of age.
- This Playcenter is designed for a specific number of occupants whose combined weight should not exceed the designated weight on the elevated floor or the swing area. The total unit capacity is outlined in the Basic Setup Dimensions section of instruction manual. The maximum fall height and recommended play area is also available in the Basic Setup Dimensions section of the manual.
- On-site, continuous adult supervision is **REQUIRED. MOST SERIOUS INJURIES AND DEATHS ON PLAYGROUND EQUIPMENT HAVE OCCURRED WHILE CHILDREN WERE UNSUPERVISED!**
- **DO NOT** allow children to walk close to, in front of, behind, or between moving swings or other moving playground equipment.
- **DO NOT** let children stand on swings.
- Children should **NOT** twist the chains and ropes and should not loop them over the top support bar, this could reduce the strength of the chain or rope.
- **DO NOT** let children push empty seats. The seat could hit them and cause serious injury.
- Instruct and teach children to sit in the center of the swings with their full weight on the seats.
- **DO NOT** allow children to use the equipment in a manner other than intended.
- Instruct children **NOT** to get off equipment while it is in motion.
- Instruct children to **ALWAYS** go down slides feetfirst. Never slideheadfirst.
- Instruct children to **LOOK** before they slide to make sure no one is at the bottom.
- **DO NOT** allow children to go down slide head first or run up slide.
- **DRESS CHILDREN APPROPRIATELY.** (Examples would include wearing well-fitting shoes and the avoidance of ponchos, scarfs, and other loose-fitting clothing that is potentially hazardous while using equipment). Children must wear shoes when using the play set. Do not allow children to wear open toe or heel footwear like sandals, flip-flops or clogs.
- **DO NOT** allow children to climb when the equipment is wet.
- Children should **NEVER** jump from a fort deck. They should always use the ladder, ramp or slide.
- Children should **NEVER** be allowed to crawl or walk across the top of monkey bars.
- **DO NOT** allow children to crawl on top of a fort roof.
- Verify that any suspended climbing ropes, chain, or cable are secured at both ends and that they cannot be looped back on themselves as to create an entanglement hazard.
- **DO NOT** let children attach items to the playground equipment that are not specifically designed for use with the equipment. Items such as, but not limited to, jump ropes, clothesline, pet leashes, cables and chain can cause a strangulation hazard.
- Children should **NEVER** wrap their legs around swing chain.
- **DO NOT** allow children to slide down the swing chain.
- Instruct children to remove their bike or other sports helmet before playing on playground equipment.
- **NEVER** add extra length to chain or rope. The chains or ropes provided are the maximum length designed for the swinging element(s).
- On sunny and/or hot days, check the slide and other plastic rides to assure that they are not hot to the touch to cause burns. Cool hot slide and rides with water and wipe dry prior to using.

Modifications

- Modifications made by the consumer to the original activity toy shall be carried out according to the instructions of the manufacturer. In particular, instructions shall be provided with kit/accessory about the installation of rope/nets concerning the minimum diameter, the need for fixation at both ends, overall length, and positioning in relation to other structures.



Positioning Your Playcenter

- The playcenter is designed to be installed on a level surface by an adult with an adult helper. Place in a flat area of your yard to minimize ground preparation.
- Choose a level location for the equipment. This can reduce the likelihood of the play set tipping over and loose-fill surfacing material washing away during heavy rains.
- Place the equipment not less than 6 ft (1.8 m) from any structure or obstruction such as a fence, garage, house, overhanging branches, laundry lines, or electrical wires.
- Provide enough room so that the children can use the equipment safely. For example, for structures with multiple play activities, a slide should not exit in front of a swing.
- It is a good idea to place your playcenter in an area that is convenient for adults to watch children at play.
- Create a site free of obstacles that could cause injuries – such as low overhanging tree branches, overhead wires, tree stumps and/or roots, large rocks, bricks and concrete. Additional suggestions in the Suggested Playground Surfacing Section.
- Do not build your playset on top of surfacing material.
- Locate bare metal platforms and slides out of direct sunlight to reduce the likelihood of serious burns. A slide that faces north will receive the least direct sunlight.
- Separate active and quiet activities from each other. For example, locate sandboxes away from swings or use a guardrail or barrier to separate the sandbox from the movement of the swings.

Suggested Playground Surfacing

- Do not install home playground equipment over concrete, asphalt, packed earth, grass, carpet, or any other hard surface. A fall onto a hard surface can result in serious injury to the equipment user.
- Do not install loose fill surfacing over hard surfaces such as concrete or asphalt.
- Shredded bark mulch, wood chips, fine sand and fine gravel, are added as shock absorbing materials after assembly. If used properly these materials can absorb some of the impact of a child's fall.
- All surface material should extend a minimum of 6ft (1.8m) feet in all directions around the play area.
- Do not apply playground surfacing until after the unit is completely constructed. Playset should not be built on top of surfacing.
- Use containment, such as digging out around the perimeter and/or lining the perimeter with landscape edging.
- Installations of rubber tiles or poured-in-place surfaces (other than loose-fill materials) generally require a professional and are not "do-it-yourself" projects.
- Shall use Playground Surfacing Materials (other than loose-fill material) which comply with the safety standard ASTM F1292 Standard Specification of Impact Attenuation of Surfacing Materials within the Use Zone of Playground Equipment.

The following chart explains the fall height in feet from which a life threatening head injury would not be expected

Critical Heights in feet (m) of Tested Materials

| Material | Uncompressed Depth | | | Compressed Depth to 9" (228mm) |
|----------------------------|--------------------|-------------------|--------------|-----------------------------------|
| | 6" (152mm) | 9" (228mm) | 12" (304mm) | |
| Wood Chips | 7' (2.13m) | 10-12' (3.0-3.6m) | 11' (3.35m) | 10' (3.05m) |
| Double-Shredded Bark Mulch | 6' (1.83m) | 10-12' (3.0-3.6m) | 11' (3.35m) | 7' (2.13m) |
| Engineered Wood Fibers | 6' (1.83m) | 7' (2.13m) | >12' (3.66m) | 6' (1.83m) |
| Fine Sand | 5' (1.52m) | 5' (1.52m) | 9' (2.74m) | 5' (1.52m) |
| Coarse Sand | 5' (1.52m) | 5' (1.52m) | 6' (1.83m) | 4' (1.22m) |
| Fine Gravel | 5' (1.52m) | 7' (2.13m) | 10' (3.05m) | 6' (1.83m) |
| Medium Gravel | 5' (1.52m) | 5' (1.52m) | 6' (1.83m) | 5' (1.52m) |
| Shredded Tires* | 10-12' (3.0-3.6m) | N/A | N/A | N/A |

*This data is from tests conducted by independent testing laboratories on a 6-inch depth of uncompressed shredded tire samples produced by four manufacturers. The tests reported critical heights, which varied from 10 feet to greater than 12 feet. It is recommended that persons seeking to install shredded tires as a protective surface request test data from the supplier showing the critical height of the material when it was tested in accordance with ASTM F1292.



APPENDIX A

The following information is from the United States Consumer Product Safety Commission's Information Sheet for playground surfacing material; also see the following website for additional information: www.cpsc.gov

X3. SECTION 4 OF THE CONSUMER PRODUCT SAFETY COMMISSION'S OUTDOOR HOME PLAYGROUND SAFETY HANDBOOK⁹

X3.1 Select Protective Surfacing—One of the most important things you can do to reduce the likelihood of serious head injuries is to install shock-absorbing protective surfacing under and around your play equipment. The protective surfacing should be applied to a depth that is suitable for the equipment height in accordance with ASTM Specification F 1292. There are different types of surfacing to choose from; whichever product you select, follow these guidelines:

X3.1.1 Loose-Fill Materials:

X3.1.1.1 Maintain a minimum depth of 9 inches of loose-fill materials such as wood mulch/chips, engineered wood fiber (EWF), or shredded/recycled rubber mulch for equipment up to 8 feet high; and 9 inches of sand or pea gravel for equipment up to 5 feet high. NOTE: An initial fill level of 12 inches will compress to about a 9-inch depth of surfacing overtime. The surfacing will also compact, displace, and settle, and should be periodically refilled to maintain at least a 9-inch depth.

X3.1.2 Use a minimum of 6 inches of protective surfacing for play equipment less than 4 feet in height. If maintained properly, this should be adequate. (At depths less than 6 inches, the protective material is too easily displaced or compacted.)

NOTE: Do not install home playground equipment over concrete, asphalt, or any other hard surface. A fall onto a hard surface can result in serious injury to the equipment user. Grass and dirt are not considered protective surfacing because wear and environmental factors can reduce their shock absorbing effectiveness. Carpeting and thin mats are generally not adequate protective surfacing. Ground level equipment such as a sandbox, activity wall, playhouse or other equipment that has no elevated play surface – does not need any protective surfacing.

X3.1.3 Use containment, such as digging out around the perimeter and/or lining the perimeter with landscape edging. Don't forget to account for water drainage.

X3.1.3.1 Check and maintain the depth of the loose-fill surfacing material. To maintain the right amount of loose-fill materials, mark the correct level on play equipment support posts. That way you can easily see when to replenish and/or redistribute the surfacing.

X3.1.3.2 Do not install loose-fill surfacing over hard surfaces such as concrete or asphalt.

X3.1.4 Poured-In-Place Surfaces or Pre-Manufactured Rubber Tiles — You may be interested in using surfacing other than loose-fill materials – like rubber tiles or poured-in-place surfaces.

X3.1.4.1 Installations of these surfaces generally require a professional and are not “do-it-yourself” projects.

X3.1.4.2 Review surface specification before purchasing this type of surfacing. Ask the installer/manufacture for a report showing that the product has been tested to the following safety standard: ASTM F 1292 Standard Specification for Impact Attenuation of Surfacing Materials within the Use Zone of Playground Equipment. This report should show the specific height for which the surface is intended to protect against serious head injury. This height should be equal to or greater than the fall height – vertical distance between a designated play surface (elevated surface for standing, sitting, or climbing) and the protective surfacing below – of your play equipment

X3.1.4.3 Check the protective surfacing frequently for wear.

X3.1.5 Placement — Proper placement and maintenance of protective surfacing is essential. Be sure to:

X3.1.5.1 Extend surfacing at least 6 feet from the equipment in all directions.

X3.1.5.2 For to-fro swings, extend protective surfacing in front of and behind the swing to a distance equal to twice the height of the top bar from which the swing is suspended.

⁹This information has been extracted from the CPSC publications “Playground Surfacing — Technical Information Guide” and “Handbook for Public Playground Safety.” Copies of these reports can be obtained by sending a postcard to the: Office of Public Affairs, U.S. Consumer Product Safety Commission, Washington, D.C., 20207 or call the toll-free hotline: 1-800-638-2772.

The American Society for Testing and Materials takes no position respecting the validity of any parent right asserted in connection with any item mentioned in this standard. Users of this standard are expressly advised that determination of the validity of any such parent rights, and the risk of infringement of such rights, are entirely their own responsibility.

The standard is subject to revision at any time by the responsible technical committee and must be reviewed every five years and if not revised, either approved or withdrawn. Your comments are invited either for revision of this standard or for additional standards and should be addressed to ASTM Headquarters. Your comments will receive careful consideration at a meeting of the responsible technical committee, which you may attend. If you feel that your comments have not received a fair hearing you should make your views known to the ASTM Committee on Standards. 100 Barr Harbor Drive, West Conshohocken, PA 19428.



IT IS IMPORTANT TO CHECK AND TIGHTEN ALL HARDWARE AT THE BEGINNING AND DURING THE SEASON AS THEY MAY LOOSEN DUE TO WOOD EXPANSION AND CONTRACTION.

At the beginning of each play season

- Tighten all hardware.
- Lubricate all metallic moving parts per manufacturer's instructions.
- Check all protective coverings on bolts, pipes, edges, and corners. Replace if they are loose, cracked, or missing.
- Check all moving parts including swing seats, ropes, cables, and chains for wear, rust, or other deterioration. Replace as needed.
- Check metal parts for rust. If found, sand and repaint using a non lead-based paint meeting the requirements of 16 CFR 1303.
- Check all wood members for deterioration and splinters. Sand down splinters and replace deteriorating wood members.
- Reinstall any plastic parts, such as swing seats or any other items that were removed for the cold season.
- Rake and check depth of loose fill protective surfacing materials to prevent compaction and to maintain appropriate depth. Replace as necessary.

Twice a month during play season

- Tighten all hardware.
- Check all protective coverings on bolts, pipes, edges, & corners. Replace if they are loose, cracked, or missing.
- Rake and check depth of loose fill protective surfacing materials to prevent compaction and to maintain appropriate depth. Replace as necessary.

Once a month during play season.

- Lubricate all metallic moving parts per manufacturer's instructions.
- Check all moving parts including swing seats, ropes, cables, and chains for wear, rust, or other deterioration. Replace as needed.

At the end of each season or when the temperature drops below 32° F

- Remove plastic swing seats and other items as specified by the manufacturer and take indoors or do not use.
- Rake and check depth of loose fill protective surfacing materials to prevent compaction and to maintain appropriate depth. Replace as necessary.

Additional Maintenance

- Check the swing beam and hardware every two weeks due to wood expansion and contraction. It is particularly important that this procedure be followed at the beginning of each season.
- Inspect wood parts monthly. The grain of the wood sometimes will lift in the dry season causing splinters to appear. Light sand may be necessary to maintain a safe playing environment. Treat your playset with stain regularly, to help prevent severe checking/ splitting and other weather damage.
- A waterborne transparent stain has been applied to your playset. This is done for color only. Once or twice a year, depending on your climate conditions, you must apply some type of protection (sealant) to the wood of your unit. Prior to the application of sealant, lightly sand any "rough" spots on your playset. Please note this is a requirement of your warranty.
- Assembling and maintaining the playset on a level location is very important. As your children play, your playset will slowly dig its way into the soil, and it is very important that it settles evenly. Make sure the playset is level and true one each year or at the beginning of each play season.

Disposal Instructions

When the Playcenter use is no longer desired, it should be disassembled and disposed of in such a way that no unreasonable hazards will exist at the time the unit is discarded.

Third Party Assembly

Customer may, in their sole discretion, elect to use a third party person or service to assemble this product. Backyard Discovery assumes no responsibility or liability for any charge incurred by the Customer for any assembly services'. Please see our warranty for more information about damaged and missing part replacement coverage. Backyard Discovery will not reimburse Customer for the price of parts purchased.

OWNERS SHALL BE RESPONSIBLE FOR MAINTAINING THE LEGIBILITY OF THE WARNING LABELS



Your Backyard Discovery structure is designed and constructed of quality materials. As with all outdoor products it will weather and wear. To maximize the enjoyment, safety and life of your structure it is important that you properly maintain it.

About Our Wood

Backyard Discovery uses 100% Cedar (C. Lanceolata) wood. Although we take great care in selecting the best quality lumber available, wood is still a product of nature and susceptible to weathering which can change the appearance of your set.

What causes weathering? Does it affect the strength of my product?

One of the main reasons for weathering is the effects of water (moisture); the moisture content of the wood at the surface is different than the interior of the wood. As the climate changes, moisture moves in or out of the wood, causing tension which can result in checking and or warping. You can expect the following due to weathering. These changes will not affect the strength of the product:

1. Checking is surface cracks in the wood along the grain. A post (4" x 4") will experience more checking than a board (1" x 4") because the surface and interior moisture content will vary more widely than in thinner wood.

2. Warping results from any distortion (twisting, cupping) from the original plane of the board and often happens from rapid wetting and drying of the wood.

3. Fading happens as a natural change in the wood color as it is exposed to sun-light and will turn grey over time.

How can I reduce the amount of weathering to wood product?

1. Your wood product is coated with a water-based stain. Sunlight will break down the coating, so we recommend applying a water repellent or stain on a yearly basis (see your local stain and paint supplier for a recommended product). You must apply some type of protection (sealant) to the wood of your product. **Please note this is a requirement of your warranty.** Most weathering is just the normal result of nature and will not affect safety. However if you are concerned that a part has experienced a severe weathering problem please call our customer service department for further assistance.

2. Inspect wood parts monthly. The grain of the wood sometimes will lift in the dry season causing splinters to appear. Light sanding may be necessary to maintain a safe environment. Treating your Product with protection (sealant) after sanding will help prevent severe checking/ splitting and other weather damage.



Protrusion Hazard

Incorrect

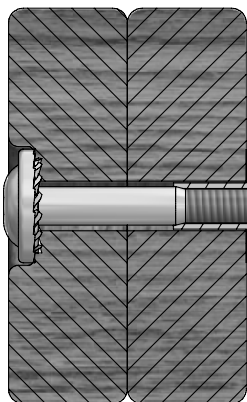

If you see exposed threads and your bolt protrudes beyond the T-Nut you may have overtightened the bolt or used incorrect hardware. If you've overtightened, remove the bolt and add washers to eliminate the protrusion.

Correct

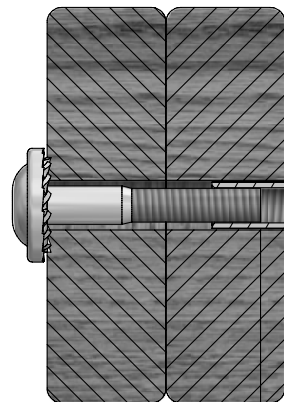

1/8"

Proper Hardware Assembly

Bolt and T-Nut Assembly

Tap T-nut into the provided hole. Insert your bolt through the lock washer and insert into the provided hole opposite from the T-Nut. Turn clockwise to thread into T-nut. Do not completely tighten until instructed.

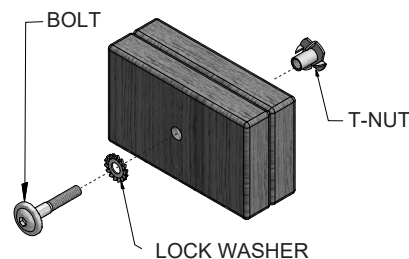

Bolt and Barrel Nut Assembly

Insert barrel nut through the lock washer and press the pair through the provided hole. Insert your bolt through the second lock washer and insert the pair into the provided hole opposite from the barrel nut. Turn clockwise to thread into the barrel nut. Do not completely tighten until instructed.

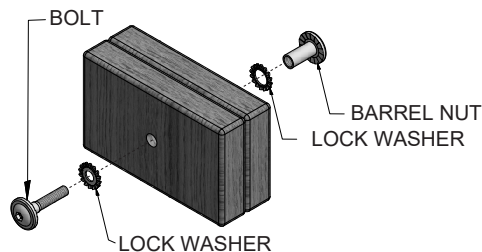

Lag Assembly

Normally there will be a pre-drilled pilot hole on assemblies that require a Lag Screw. If there is no pilot hole, line up the two boards as they are to be attached and use the factory drilled hole as a guide to drill another pilot hole into the adjoining board. This will keep the wood from splitting. Only a lock washer is required for steps with Lag Screws.

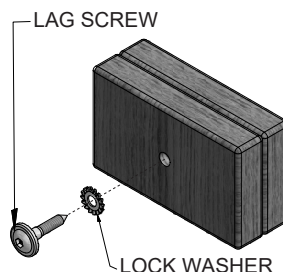



ASSEMBLY TIP:

Keep and eye out for these boxes which will contain helpful pictures and information making the assembly process as quick and painless as possible.

Sorting Wood

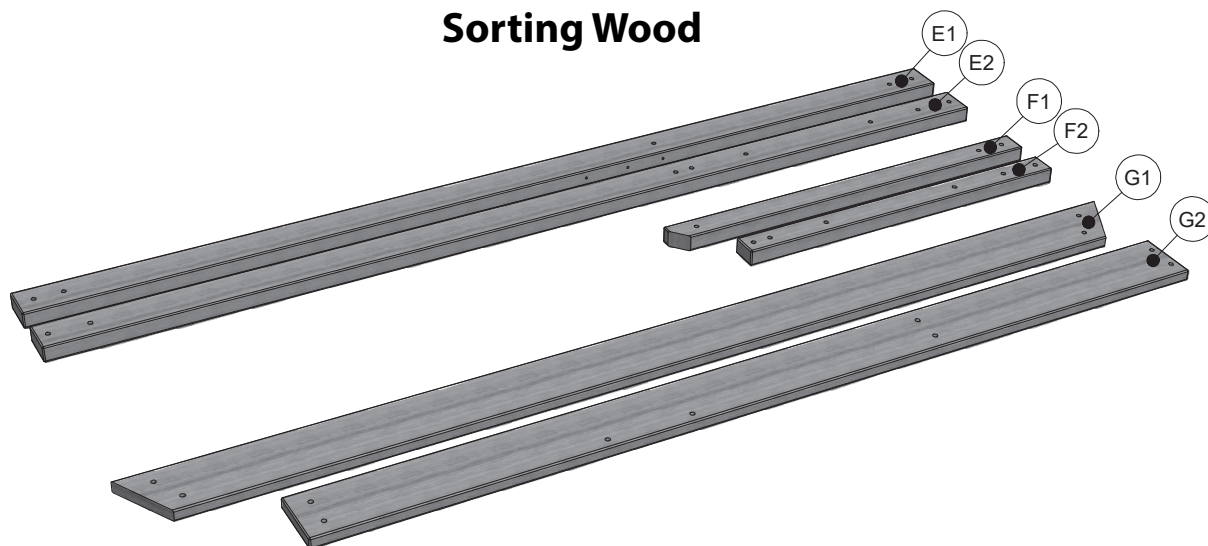

When removing the wood from the boxes we recommend arranging them by part number before you begin assembly. This will allow for faster assembly and easily identify any parts that may be missing or damaged.

Sorting Hardware

NUT BARREL
H100545



SCREW
H100695



T-NUT
H100699



WASHER FLAT
H100706



BOLT HEX
H100716



BOLT
H100718

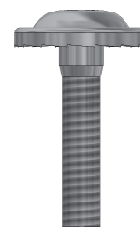

SCREW PWH
H100742



To help with assembly we recommend sorting your hardware bags with the seven digit alpha-numeric number printed on the bags or by hardware type (i.e. bolts, nuts, etc.). Organizing your hardware will make assembly easier.

Hardware Identification

Hardware bags are printed with a seven digit alpha-numeric part number. During assembly you only need to reference the last three digits of the part number as noted in each step. This will make finding the correct hardware easier.

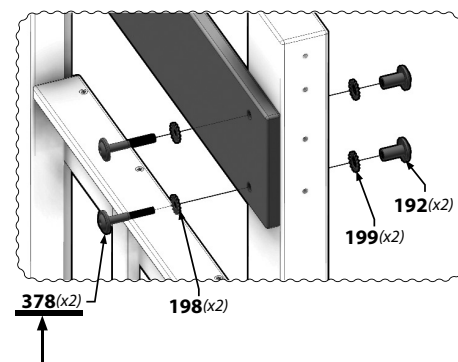
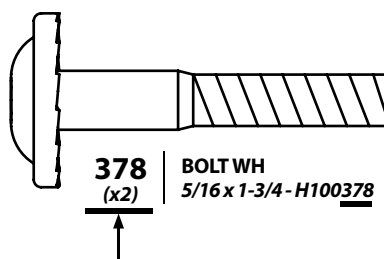

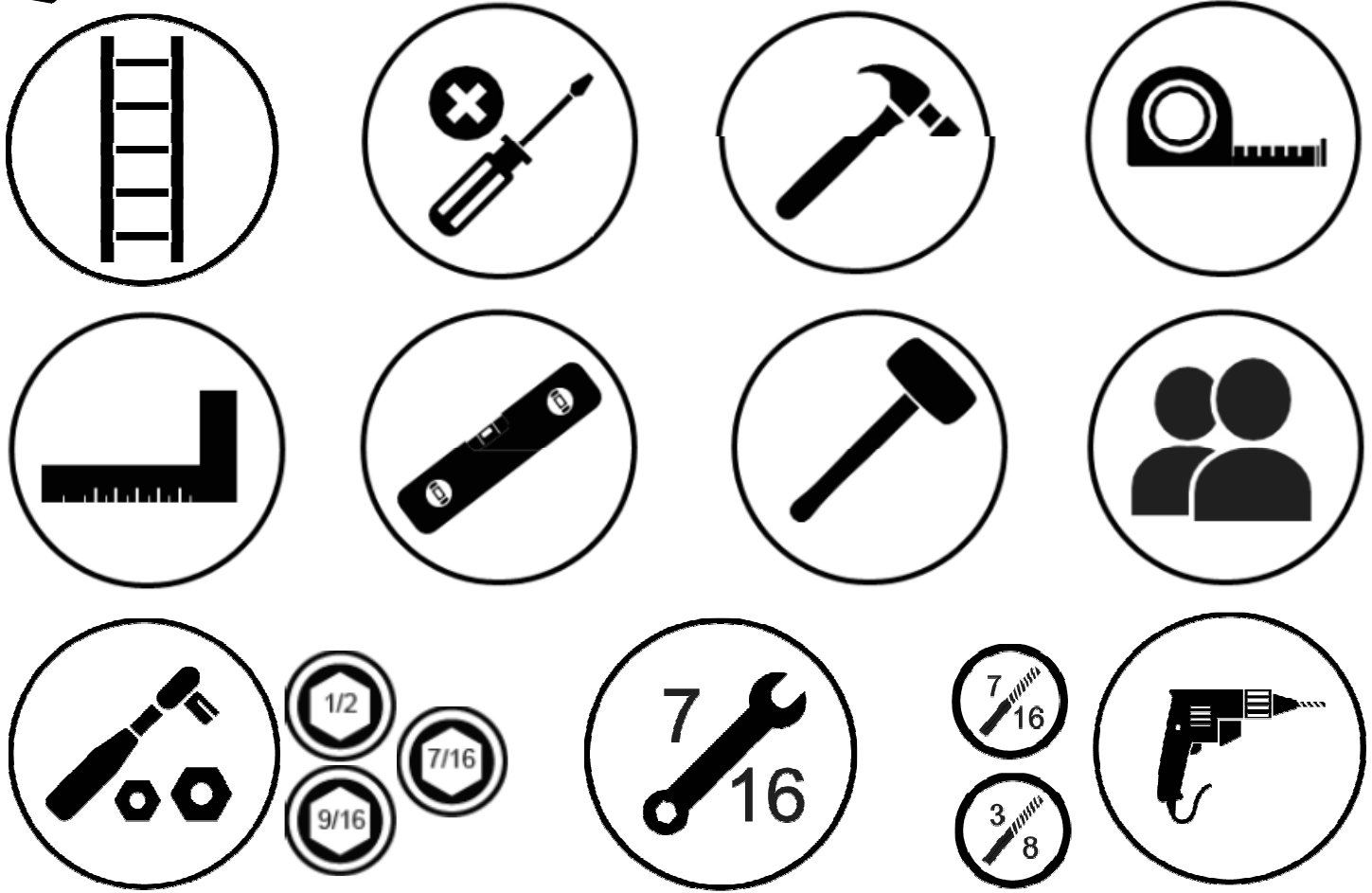
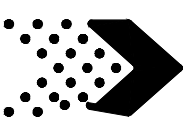

Icons and their uses you will see throughout this manual

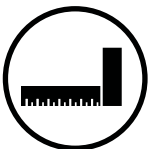

You will need to make sure that your assembly is square before tightening your bolts.



For proper assembly you will need to ensure that your structure is level before proceeding to the next step.



Some steps in the assembly process will require an extra set of hands. Make sure you have a helper available.



This icon shows the size of an open ended wrench. Using the wrench as the fraction bar.



When you see this icon you will need a socket wrench. The icons below show the size of attachments needed for assembly 1/2.

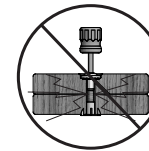

This icon warns you to not over tighten your bolts. This is to prevent structural damage and also splintering your wood.

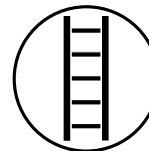

When you see this icon you will need a ladder to complete the step. Do NOT stand on the set when it is unstable and not anchored. Failure to do so may result in injury.



This icon will show you what drill attachments are needed. For this example you will need a Phillips head attachment and 3/8 socket.

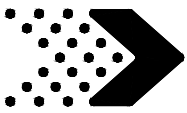

Place the set on level ground, not less than 6'-7" [2 m] from any structure or obstruction such as a fence, garage, house, overhanging branches, laundry lines, or electrical wires.

- While assembling unit, take time before and after each phase to make sure fort is level. If fort is not level, assembly will be difficult and improper assembly may result. Extra care must be taken to insure the fort is square.
- The safe play area refers to a zone extending 6'-7" (2m) beyond the play product on all sides, including the space above the play product.

SAFE PLAY AREA DIAGRAM

Ground Dimension

19'-7" x 14'-3 1/4" x 10'-2 3/4"
6m x 4.4m x 3.1m

Safe Play Area

32'-8 1/2" x 27'-4 7/8"
10m x 8.4m

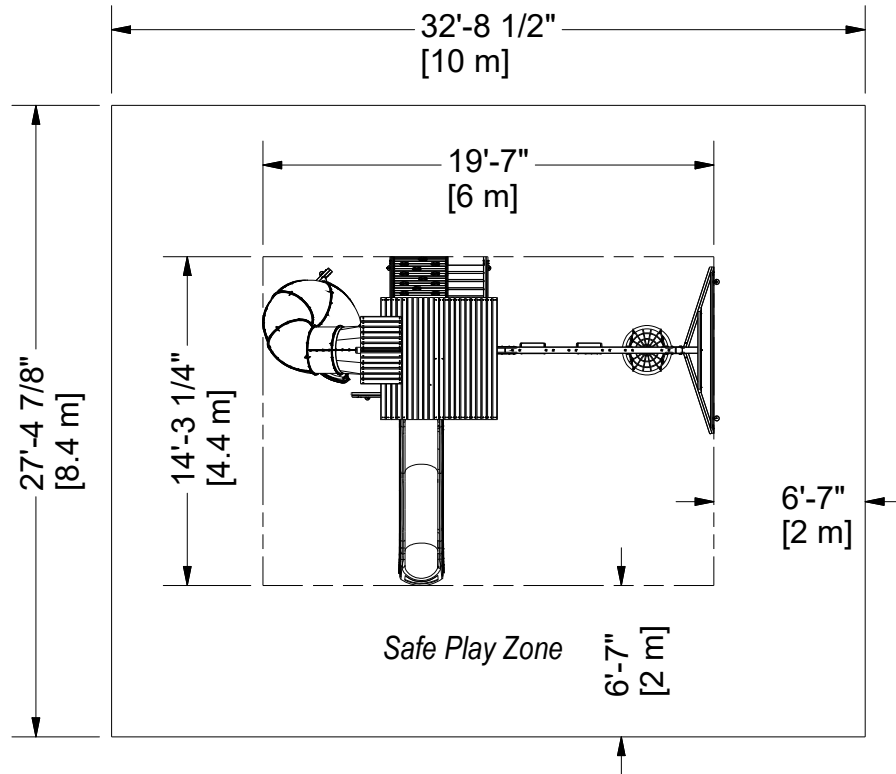

SAFE PLAY HEIGHT: 16'-9 3/4" [5.1 m]
MAXIMUM FALL HEIGHT: 7'-1/4" [2.1 m]

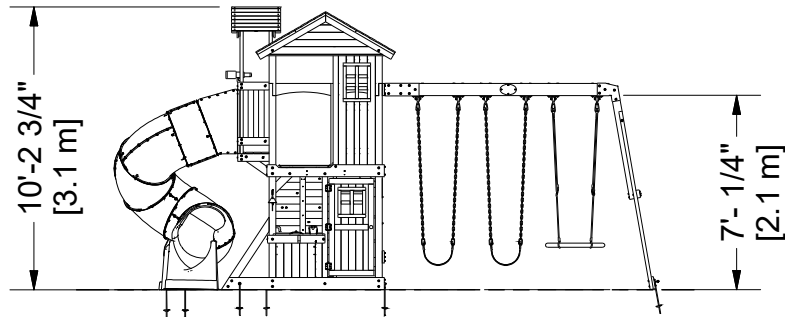

General Information:

Your set has been designed and engineered for children only and for residential use only.
A maximum of 150 lbs. per child is recommended for play activities designed for individual use.
A maximum of 120 lbs. per child is recommended for play activities designed for multiple child use.
A maximum of 9 children is recommended for this swing set.

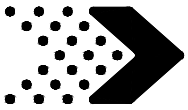

A1 | **SWING BEAM - W4L12440**
 (x1) | 3 3/8"x5 1/4"x89 1/2" (86x134x2274)



A2 | **SB 9" BLOCK - W4L12441**
 (x1) | 3 3/8"x5 1/4"x9" (86x134x228)



B1 | **POST - W4L12286**
 (x1) | 3"x3"x89 1/2" (76x76x2274)



B2 | **POST - W4L12287**
 (x1) | 3"x3"x89 1/2" (76x76x2274)



B3 | **POST - W4L12288**
 (x1) | 3"x3"x89 1/2" (76x76x2274)



B4 | **POST - W2A02758**
 (x1) | 3"x3"x89 1/2" (76x76x2274)



B5 | **UPPER POST - W4L12397**
 (x2) | 3"x3"x21 1/4" (76x76x541)

B6 | **UPPER POST - W4L12428**
 (x2) | 3"x3"x21 1/4" (76x76x541)

E1 | **BRACE - W4L12312**
 (x3) | 1 3/8"x3 3/8"x13 5/8" (36x86x347)



E2 | **BRACE - W4L12418**
 (x2) | 1 3/8"x3 3/8"x13 7/8" (36x86x351)

E4 | **S.B. ANGLE BRACE - W4L12444**
 (x2) | 1 3/8"x3 3/8"x88 3/4" (36x86x2254)

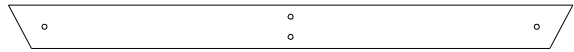

E3 | **BRACE - W4L12500**
 (x1) | 1 3/8"x3 3/8"x37 3/4" (36x86x959)

E5 | **S.B. END SUPPORT - W4L12443**
 (x1) | 1 3/8"x3 3/8"x44 1/8" (36x86x1120)

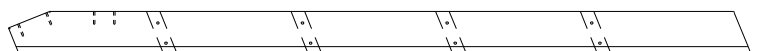
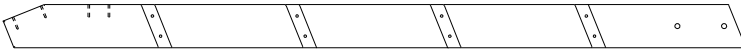

E6 | **LEFT UPRIGHT - W4L12490**
 (x1) | 1 3/8"x3 3/8"x58" (36x86x1474)

E7 | **MIDDLE UPRIGHT - W4L12491**
 (x1) | 1 3/8"x3 3/8"x58" (36x86x1474)

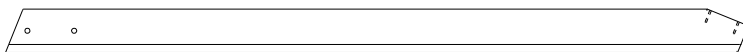

E8 | **RIGHT UPRIGHT - W4L12495**
 (x1) | 1 3/8"x3 3/8"x58" (36x86x1474)

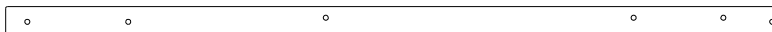

F1 | **WALL UPRIGHT - W4L12398**
 (x2) | 1 3/8"x2 3/8"x60 3/8" (36x60x1533)

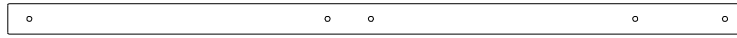
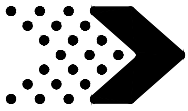

F2 | WALL UPRIGHT - W4L12405
(x2) | 1 3/8"x2 3/8"x57 3/4" (36x60x1467)



F3 | DOOR STOP - W4L12501
(x2) | 1 3/8"x1 3/8"x3 7/8" (36x36x100)



G1 | GROUND BOARD - W4L12290
(x1) | 1"x5 1/4"x70 3/4" (24x134x1798)



G2 | GROUND BOARD - W4L12291
(x1) | 1"x5 1/4"x72 1/4" (24x134x1835)



G4 | GROUND BOARD - W4L12293
(x1) | 1"x5 1/4"x72 1/4" (24x134x1835)



G3 | GROUND BOARD - W4L12292
(x1) | 1"x5 1/4"x49 1/8" (24x134x1248)

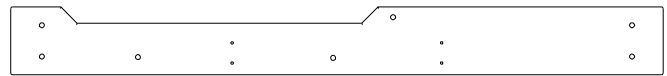

G5 | DECK RAIL - W4L12294
(x1) | 1"x5 1/4"x51" (24x134x1296)



G6 | DECK RAIL - W4L12295
(x1) | 1"x5 1/4"x47" (24x134x1194)



G7 | DECK RAIL - W4L12296
(x1) | 1"x5 1/4"x51" (24x134x1296)



G8 | DECK RAIL - W4L12297
(x1) | 1"x5 1/4"x47" (24x134x1194)



G9 | UPPER DECK RAIL - W4L12299
(x1) | 1"x5 1/4"x50 1/8" (24x134x1272)

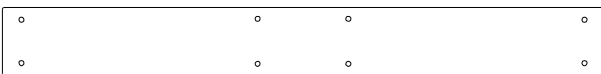

G10 | UPPER DECK RAIL - W4L12301
(x1) | 1"x5 1/4"x47" (24x134x1194)



G12 | CROSS SUPPORT - W4L12315
(x1) | 1"x5 1/4"x65 1/4" (24x134x1658)



G14 | COUNTER TOP SUPPORT - W4L12322
(x3) | 1"x5 1/4"x9 7/8" (24x134x250)



G13 | CROSS SUPPORT - W4L12314
(x1) | 1"x5 1/4"x65 1/4" (24x134x1658)

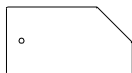

G15 | COUNTER TOP SUPPORT - W4L12425
(x1) | 1"x5 1/4"x9 7/8" (24x134x250)

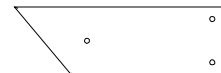

G17 | CROSS BRACE - W4L12966
(x2) | 1"x5 1/4"x17" (24x134x430)

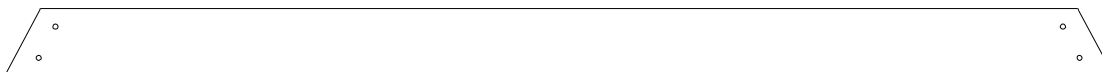

G16 | GROUND BOARD - W4L12442
(x1) | 1"x5 1/4"x86 3/4" (24x134x2202)

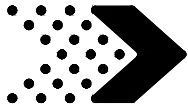

Parts Identification

Wood Components (Not to Scale)



H1 | DECK SUPPORT - W4L12306
(x2) | 1"x3 3/8"x47" (24x86x1194)



H3 | DECK SUPPORT - W4L12410
(x1) | 1"x3 3/8"x11 3/4" (24x86x297)



H5 | DECK SUPPORT - W4L12408
(x1) | 1"x3 3/8"x30 3/8" (24x86x772)



H7 | TOP RAIL BOARD - W4L12404
(x1) | 1"x3 3/8"x30 3/8" (24x86x772)



H9 | FACIA - W4L12402
(x1) | 1"x3 3/8"x49 1/8" (24x86x1248)

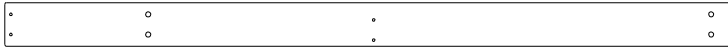

H11 | FACIA - W4L12401
(x1) | 1"x3 3/8"x56 3/4" (24x86x1440)



H13 | FACIA - W4L12427
(x1) | 1"x3 3/8"x49 1/8" (24x86x1248)



H15 | COUNTER SUPPORT - W4L12424
(x1) | 1"x3 3/8"x3 3/4" (24x86x94)

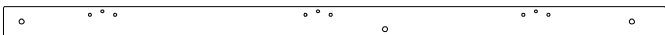

J1 | WALL UPRIGHT - W4L12303
(x1) | 1"x2 3/8"x51 3/4" (24x60x1314)

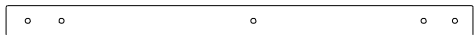

J3 | WALL UPRIGHT - W4L12396
(x1) | 1"x2 3/8"x36 1/2" (24x60x927)



K1 | WALL BOARD - W4L12399
(x2) | 5/8"x5 1/4"x52 3/8" (16x134x1329)



K3 | COUNTER TOP - W4L12318
(x1) | 5/8"x5 1/4"x23 5/8" (16x134x600)



H2 | DECK SUPPORT - W4L12403
(x2) | 1"x3 3/8"x13 5/8" (24x86x345)

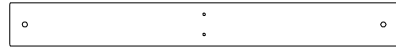

H4 | DECK SUPPORT - W4L12414
(x1) | 1"x3 3/8"x30 3/8" (24x86x772)



H6 | TOP RAIL BOARD - W4L12406
(x4) | 1"x3 3/8"x13 5/8" (24x86x345)

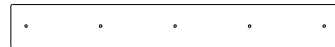

H8 | TOP RAIL BOARD - W4L12417
(x1) | 1"x3 3/8"x25 5/8" (24x86x652)



H10 | FACIA - W4L12429
(x1) | 1"x3 3/8"x51" (24x86x1296)



H12 | FACIA - W4L12400
(x1) | 1"x3 3/8"x56 3/4" (24x86x1440)



H14 | ROOF JOIST - W4L12432
(x2) | 1"x3 3/8"x30 3/8" (24x86x770)



H16 | LADDER RUNG - W4L12492
(x4) | 1"x3 3/8"x19 1/4" (24x86x489)



J2 | WALL UPRIGHT - W4L12302
(x1) | 1"x2 3/8"x52 1/2" (24x60x1334)



J4 | SLIDE ATTACHMENT BOARD - W4L12407
(x2) | 1"x2 3/8"x27 5/8" (24x60x703)



K4 | COUNTER TOP - W4L12319
(x1) | 5/8"x5 1/4"x23 5/8" (16x134x600)



Parts Identification

Wood Components (Not to Scale)

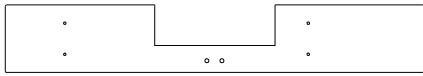

K5 | **COUNTER TOP - W4L12320**
(x1) 5/8"x5 1/4"x32 3/4" (16x134x832)



K7 | **COUNTER TOP - W4L12423**
(x1) 5/8"x5 1/4"x22 1/2" (16x134x570)



L1 | **FACIA - W4L12431**
(x1) 5/8"x4 3/8"x51" (16x112x1296)



M2 | **DECK BOARD - W4L12411**
(x2) 5/8"x3 3/8"x32 1/4" (16x86x820)



M6 | **LOWER RAIL - W4L12304**
(x1) 5/8"x3 3/8"x47" (16x86x1194)



M8 | **PICKET - W4L12395**
(x2) 5/8"x3 3/8"x21" (16x86x533)



M10 | **PICKET - W4L12323**
(x2) 5/8"x3 3/8"x21" (16x86x533)



M12 | **REAR SUPPORT - W4L12493**
(x1) 5/8"x3 3/8"x21 1/4" (16x86x541)

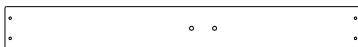

M14 | **ROCK BOARD - W4L12497**
(x4) 5/8"x3 3/8"x27 3/4" (16x86x706)

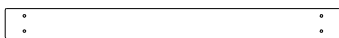

N1 | **UPPER PICKET - W4L12416**
(x4) 5/8"x2 3/8"x26 1/4" (16x60x666)



N3 | **ROOF CLEAT - W4L12433**
(x1) 5/8"x2 3/8"x3 15/16" (16x60x100)



K6 | **COUNTER TOP - W4L12321**
(x1) 5/8"x5 1/4"x32 3/4" (16x134x832)



K8 | **FACIA - W4L12430**
(x1) 5/8"x5 1/4"x51" (16x134x1296)

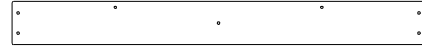

M1 | **DECK BOARD - W4L12409**
(x1) 5/8"x3 3/8"x32 1/4" (16x86x820)



M3 | **DECK BOARD - W4L12412**
(x1) 5/8"x3 3/8"x32 1/4" (16x86x820)



M5 | **LOWER RAIL - W4L12305**
(x1) 5/8"x3 3/8"x24 7/8" (16x86x632)

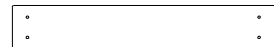

M7 | **PICKET - W4L12316**
(x7) 5/8"x3 3/8"x21" (16x86x533)



M9 | **PICKET - W4L12317**
(x1) 5/8"x2 7/8"x21" (16x74x533)



M11 | **TOP RAIL BOARD - W4L12434**
(x2) 5/8"x3 3/8"x30 3/8" (16x86x772)



M13 | **ROCK BOARD - W4L12496**
(x8) 5/8"x3 3/8"x27 3/4" (16x86x706)



M15 | **ROCK BOARD - W4L12498**
(x4) 5/8"x3 3/8"x27 3/4" (16x86x706)

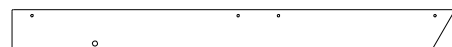

M16 | **FACIA BOARD - W4L12967**
(x4) 5/8"x3 3/8"x34 5/8" (16x86x880)



N2 | **COUNTERTOP CLEAT - W4L12426**
(x1) 5/8"x2 3/8"x5 7/8" (16x60x150)

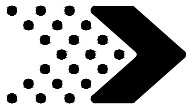

Parts Identification

Wood Components (Not to Scale)



N4 | **ROCK BOARD - W4L12499**
(x1) | 5/8"x2 3/8"x27 3/4" (16x60x706)

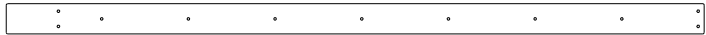

N5 | **ROCKWALL CLEAT - W4L12965**
(x1) | 5/8"x2 3/8"x54 1/2" (16x60x1385)

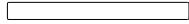

O1 | **WINDOW TRIM - W4L12419**
(x2) | 5/8"x1 3/8"x14 1/4" (16x34x361)

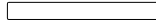

O2 | **WINDOW TRIM - W4L12420**
(x2) | 5/8"x1 3/8"x11 7/8" (16x34x301)

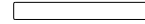

O3 | **WINDOW TRIM - W4L12435**
(x2) | 5/8"x1 3/8"x10 3/8" (16x34x265)



O4 | **WINDOW TRIM - W4L12436**
(x2) | 5/8"x1 3/8"x12" (16x34x306)

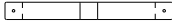

O5 | **WINDOW TRIM - W4L12437**
(x1) | 5/8"x1 3/8"x13 1/8" (16x34x333)

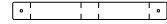

O6 | **WINDOW TRIM - W4L12438**
(x1) | 5/8"x1 3/8"x12" (16x34x306)

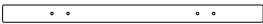

O70 | **SLIDE MOUNTING BOARD - W4L09040**
(x1) | 5/8"x1 3/8"x20 3/8" (16x34x517)



SP1 | **SWING BEAM SUPPORT - W4L12439**
(x1) | 3 3/8"x3 3/8"x49 3/8" (86x86x1254)

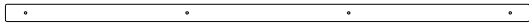

T1 | **DECK SUPPORT - W4L12308**
(x2) | 1"x1 3/8"x41" (24x34x1040)



T2 | **DECK SUPPORT - W4L12311**
(x4) | 1"x1 3/8"x3" (24x34x76)

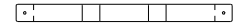

T3 | **WINDOW FRAME - W4L12421**
(x1) | 1"x1 3/8"x16 7/8" (24x34x429)



T4 | **WINDOW FRAME - W4L12422**
(x2) | 1"x1 3/8"x11 7/8" (24x34x301)

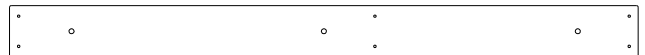

Y2 | **ATTACHMENT BOARD - W4L12494**
(x1) | 5/8"x4"x49 1/8" (16x102x1248)

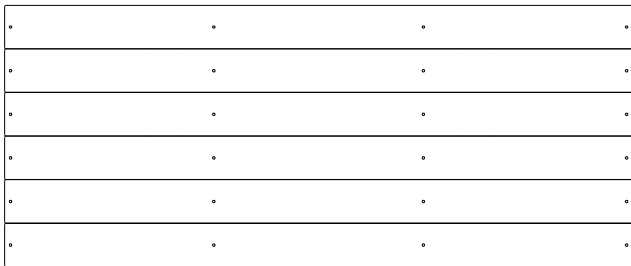

FP1 | **FLOOR PANEL - W2A02746**
(x1) | 1 1/4"x20 7/16"x49 1/16" (32x519x1247)

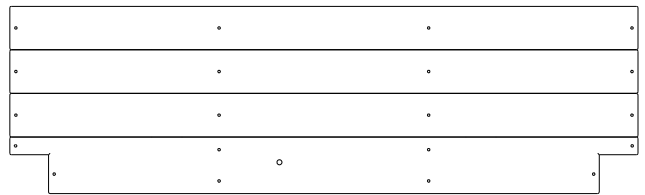

FP2 | **FLOOR PANEL - W2A02747**
(x1) | 1 1/4"x14 5/8"x49 1/16" (32x372x1247)

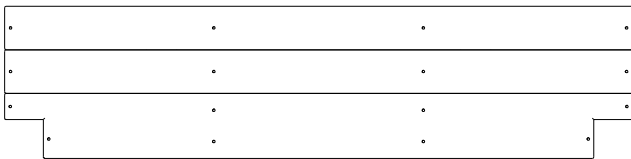

FP3 | **FLOOR PANEL - W2A02749**
(x1) | 1 1/4"x11 7/8"x49 1/16" (32x302x1247)

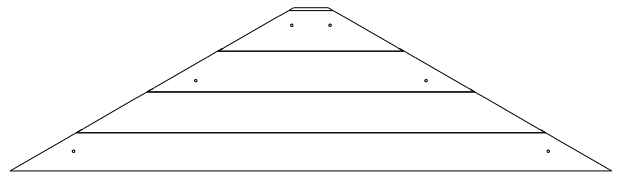

GP1 | **GUSSET PANEL - W2A02752**
(x2) | 5/8"x47"x12 3/4" (16x1194x324)

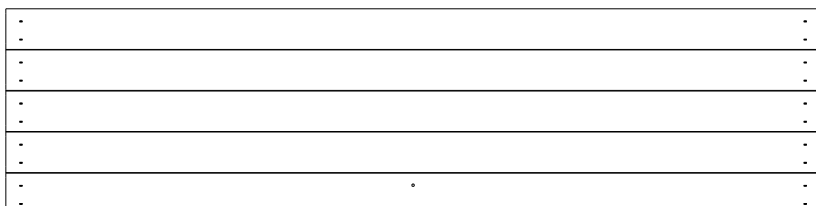

RP1 | **ROOF PANEL - W2A02753**
(x2) | 1 3/8"x15 13/16"x63 5/8" (35x401x1616)

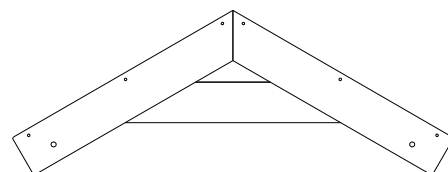

GP2 | **GUSSET PANEL - W2A02750**
(x2) | 1 1/16"x12 3/4"x34 9/16" (27x326x874)

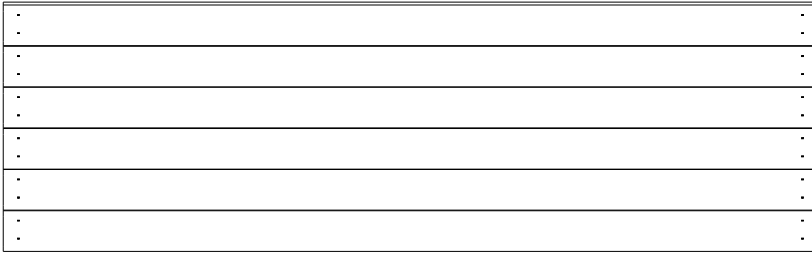
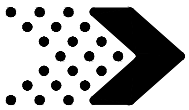

RP2 | ROOF PANEL - W2A02754
(x1) | 1 3/8"x19 7/16"x63 5/8" (35x494x1616)

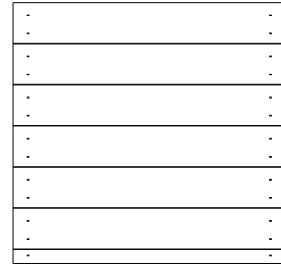

RP4 | ROOF PANEL - W2A02756
(x2) | 1 3/8"x20 3/8"x21 5/16" (35x517x541)

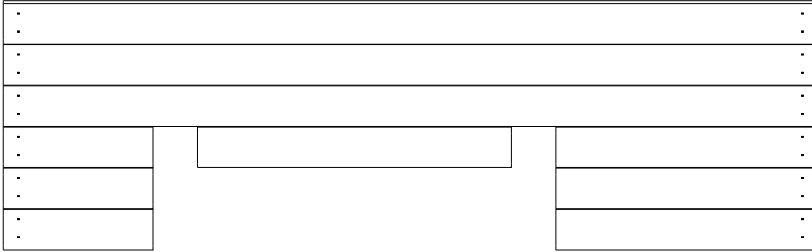

RP3 | ROOF PANEL - W2A02755
(x1) | 1 3/8"x19 7/16"x63 5/8" (35x494x1616)

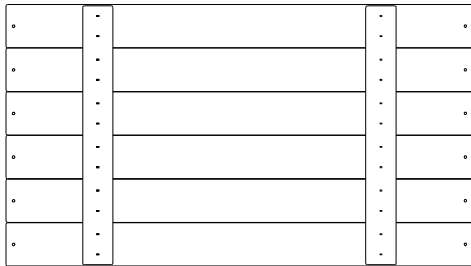

WP2 | WALL PANEL - W2A02751
(x2) | 1 1/16"x20 7/16"x36 1/2" (27x519x927)

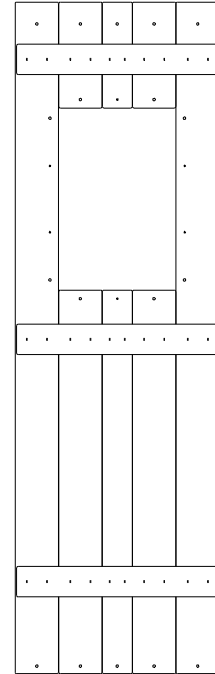

WP1 | WALL PANEL - W2A02748
(x1) | 1 1/16"x15 15/16"x52 3/8" (27x405x1331)

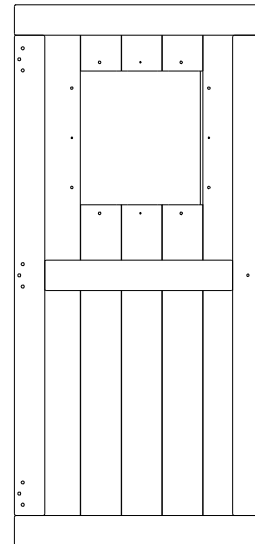

DP1 | DOOR PANEL - W2A02757
(x1) | 1 1/8"x16 1/2"x43 7/8" (27x493x1072)

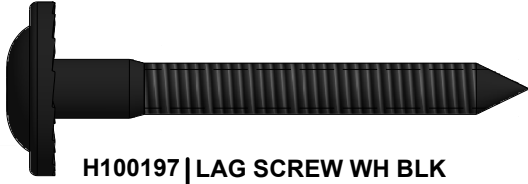
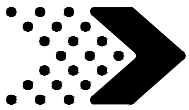

H100197 | LAG SCREW WH BLK
(x27) | 5/16x2 1/2



H100458 | LAG SCREW WH BLK
(x3) | 5/16x2



H100201 | SCREW PFH BLK
(x39) | 8x2-1/2



H100797 | SCREW PWH BLK
(x20) | 8x1



H100391 | SCREW PFH BLK
(x15) | 8x2



H100202 | SCREW PWH BLK
(x26) | 8x5/8



H100382 | SCREW PFH BLK
(x6) | 8x1 3/4



H100807 | SCREW POH BLK
(x10) | 8/32x1



H100200 | SCREW PFH BLK
(x252) | 8x1 1/2



H100806 | SCREW POH BLK
(x10) | 8/32x1 1/8



H100387 | SCREW PFH BLK
(x9) | 8x1-1/4



H100088 | SCREW PFH
(x4) | 8x1 1/8



H100380 | SCREW PFH BLK
(x138) | 8x1 1/8



H100489 | BOLT PTH BLK
(x26) | 1/4x3/4



H100385 | SCREW PFH BLK
(x2) | 8x1



H100816 | SCREW PFH BLK
(x17) | 8x7/8



H100481 | BOLT HEX BLK
(x4) | 5/16x1 1/4



H100395 | SCREW PFH BLK
(x2) | 8x3/4



H100665 | BOLT HEX SD
(x13) | 3/8x5 3/4

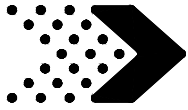

H100363 | BOLT WH BLK
(x1) | 5/16X6

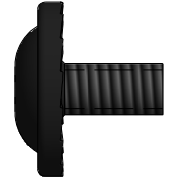

H100396 | BOLT WH BLK
(x9) | 5/16x1/2



H100534 | BOLT WH BLK
(x2) | 5/16x4 1/2



H100468 | BOLT WH BLK
(x17) | 5/16x1

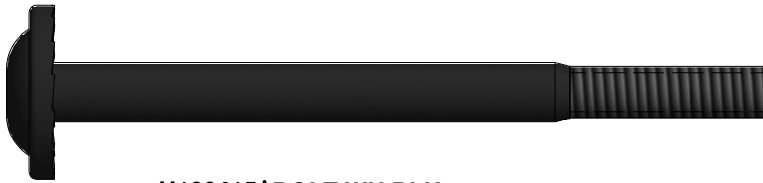

H100415 | BOLT WH BLK
(x46) | 5/16x3 3/4



H100407 | BOLT WH BLK
(x8) | 5/16x1 1/2

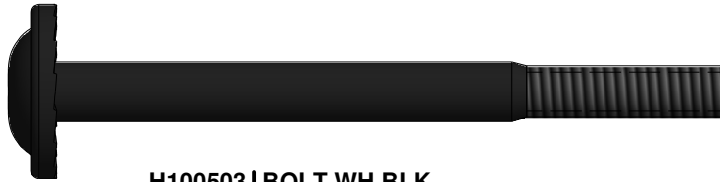

H100503 | BOLT WH BLK
(x4) | 5/16x3-1/2



H100457 | BOLT WH BLK
(x11) | 5/16x2

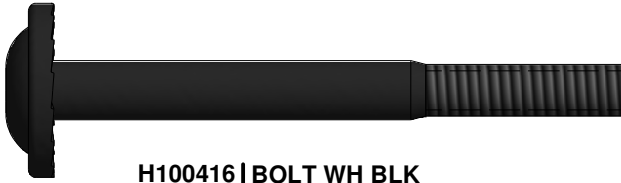

H100416 | BOLT WH BLK
(x22) | 5/16x3



H100194 | BOLT WH BLK
(x4) | 5/16x2 1/2



H100205 | BOLT WH BLK
(x25) | 5/16x2-1/4



H100831 | NUT BARREL PTH
(4) | BLK
1/4x3/4



H100832 | BOLT PTH
(4) | 1/4x3/4



H100378 | BOLT WH BLK
(x12) | 5/16x1 3/4

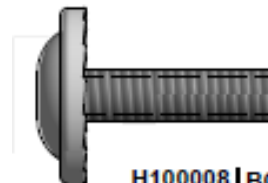

H100008 | BOLT WH
(x3) | 5/16x1



H100193 | NUT BARREL WH BLK
(x2) | 5/16x1-1/2

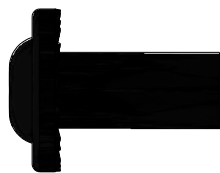

H100192 | NUT BARREL WH BLK
(x39) | 5/16x7/8



H100469 | NUT BARREL WH BLK
(x7) | 5/16x5/8

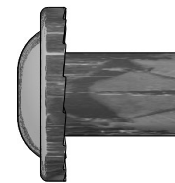

H100004 | NUT BARREL WH
(x3) | 5/16 x 5/8



H100379 | T-NUT BLK
(x110) | 5/16



H100398 | T-NUT BLK
(x26) | 1/4



H100804 | T-NUT
(x20) | 8/32



H100477 | WASHER SPLIT BLK
(x4) | 5/16



H100473 | WASHER LOCK INT BLK
(x26) | 8x15



H100199 | WASHER LOCK EXT BLK
(x36) | 12x19

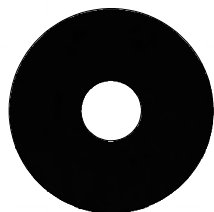

H100478 | WASHER FLAT BLK
(x4) | 8x27

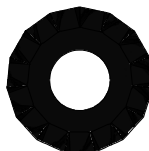

H100198 | WASHER LOCK EXT BLK
(x143) | 8x19

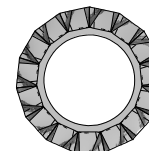

H100031 | WASHER LOCK EXT
(x3) | 12x19

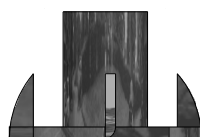

H100700 | T-NUT SD
(x13) | 3/8

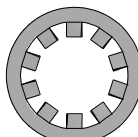

H100708 | WASHER LOCK INT SD
(x13) | 10x18

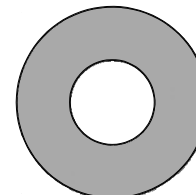

H100703 | WASHER FLAT SD
(x13) | 11x25

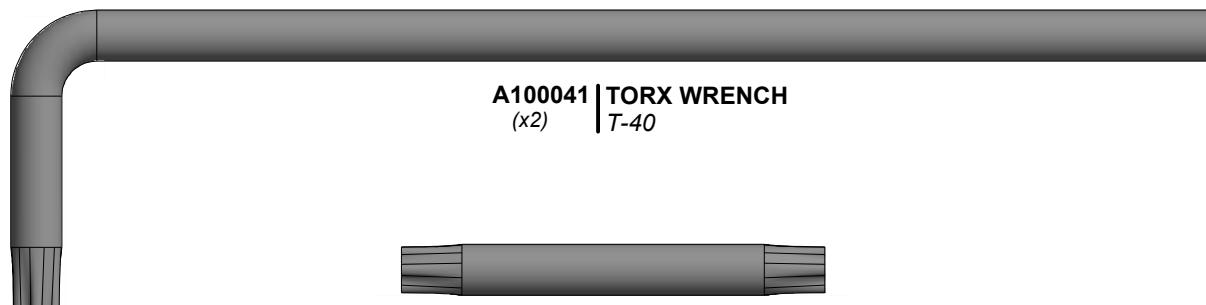

A100041 | TORX WRENCH
(x2) | T-40



A100042 | TORX BIT
(x2) | T-40

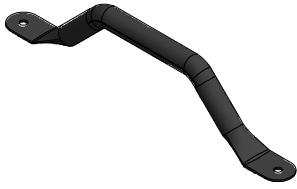
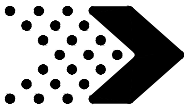

A100118 (x3) | HAND GRIP METAL GREEN 381 c/c

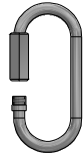

A4M00927 (x4) | QUICK LINK SD



A100164 (x1) | BYD ID TAG (LARGE) AGES 3-10

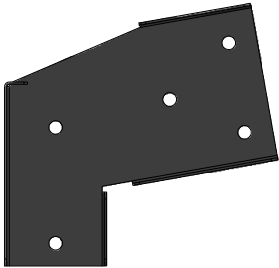

A100325 (x1) | SWING BEAM EXTENSION BRACKET-LEFT

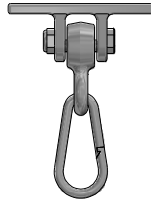

A4M00926 (x6) | CARABINER SD

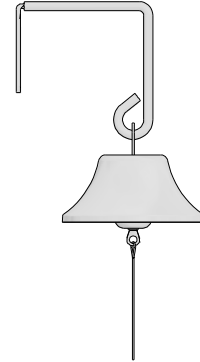

A4M01045 (1) | BELL ASSEMBLY

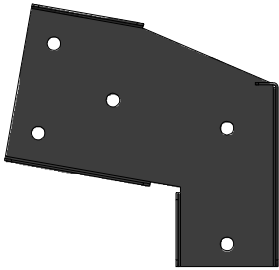

A100326 (x1) | SWING BEAM EXTENSION BRACKET-RIGHT



A100178 (x6) | METAL GROUND STAKE BROWN

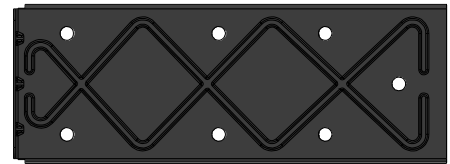

A4M00993 (x2) | EXTENDED SWING BEAM BRACKET

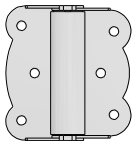

A4M00624 (x2) | HINGE (DOOR, SPRING LOADED)

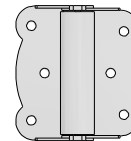

A4M00994 (x1) | HINGE (DOOR, NON-SPRING LOADED)



A100340 (x7) | L BRACKET 2.5x38x50x55



A4M01005 (x4) | CHAIN GREEN 7mm x 1452mm (57in)

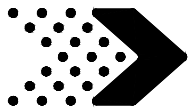

A6P00362 | 26" HD BELT SWING
(x2)



A6P00037 | GREEN HC ROCK #2
(x12)

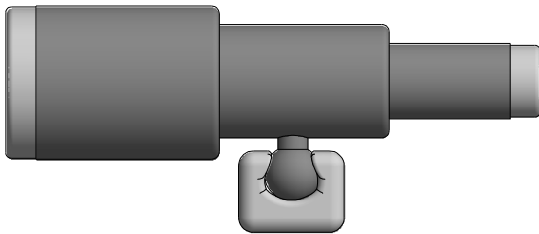

A6P00096 | Telescope
(x1)



A6P00274 | KNOB - DR.BRN
(x1)



A6P00331 | BLENDER
(x1)

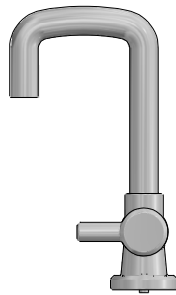

A6P00333 | FAUCET
(x1)



A6P00330 | INDUCTIVE BURNER KIT
(1)

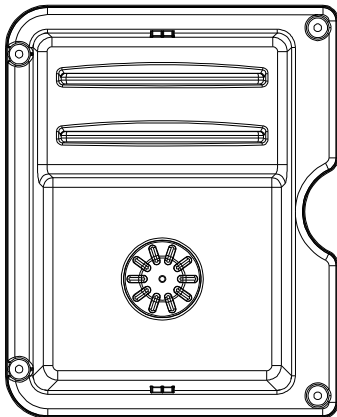

A6P00332 | PREMIUM SINK
(x1)

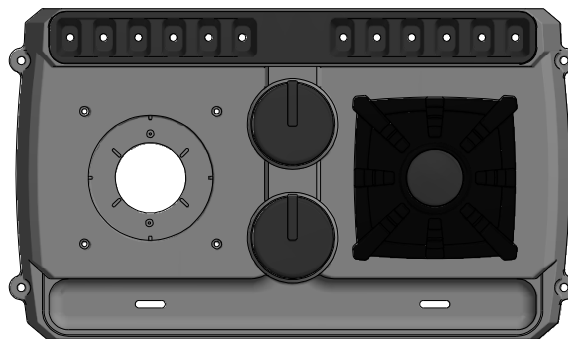

A6P00335 | STOVE BASE
(x1)

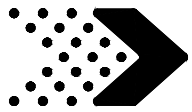

A6P00336 | BOIL POT
(x1)

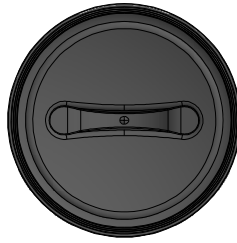

A6P00337 | POT/PAN LID
(x2)

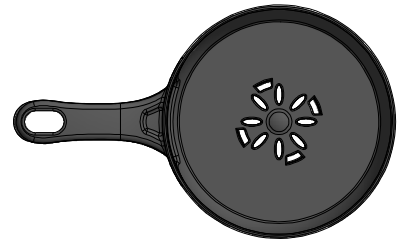

A6P00338 | FRY PAN
(x1)

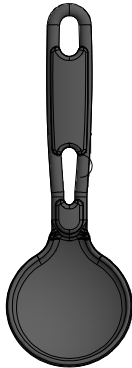

A6P00340 | LADLE
(x1)

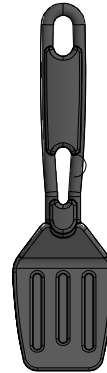

A6P00339 | SPATULA
(x1)

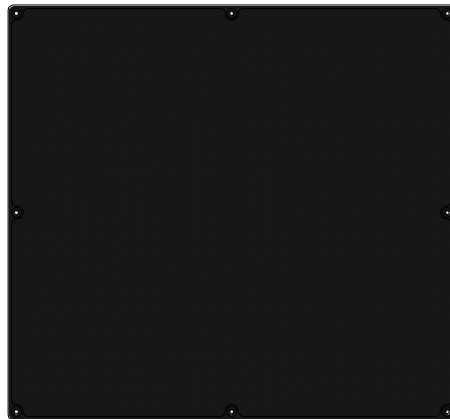

A6P00324 | CHALK BOARD LARGE
(x1)

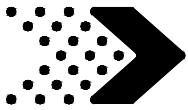

A100287 | SLIDE VF 10 FT
(x1)



A4M01126 | 26" WEB SWING
(x1)

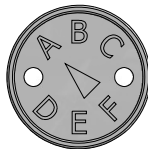

A100314 | "A" REVISION TAG
(x1)

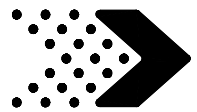

Phase 1

STEP 1

B6 | UPPER POST - W4L12428
(x1) | 3"x3"x21 1/4" (76x76x541)

B3 | POST - W4L12288
(x1) | 3"x3"x89 1/2" (76x76x2274)

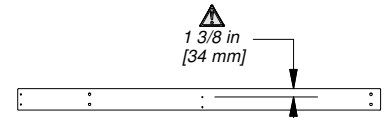

B5 | UPPER POST - W4L12397
(x1) | 3"x3"x21 1/4" (76x76x541)

B4 | POST - W2A02758-1
(x1) | 3"x3"x89 1/2" (76x76x2274)

H11 | FACIA - W4L12401
(x1) | 1"x3 3/8"x56 3/4" (24x86x1440)

G8 | DECK RAIL - W4L12297
(x1) | 1"x5 1/4"x47" (24x134x1194)

G4 | GROUND BOARD - W4L12293
(x1) | 1"x5 1/4"x72 1/4" (24x134x1835)

G10 | UPPER DECK RAIL - W4L12301
(x1) | 1"x5 1/4"x47" (24x134x1194)

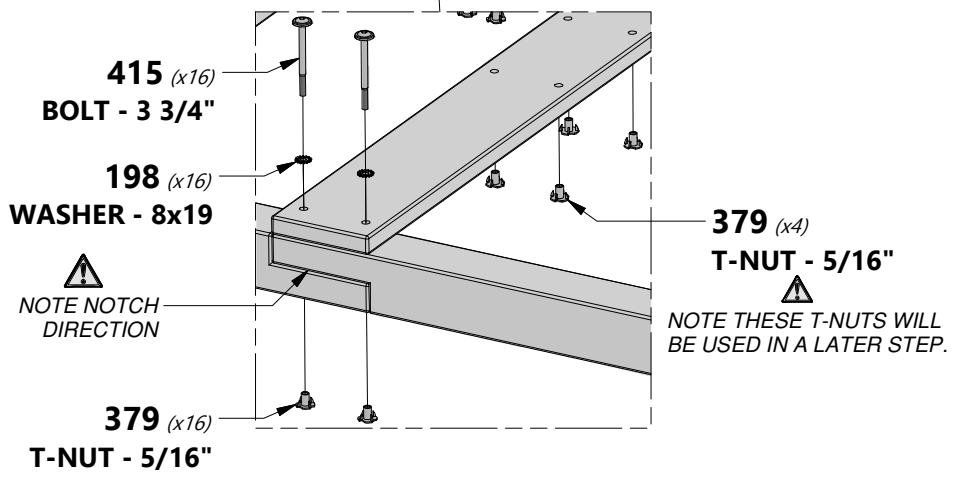
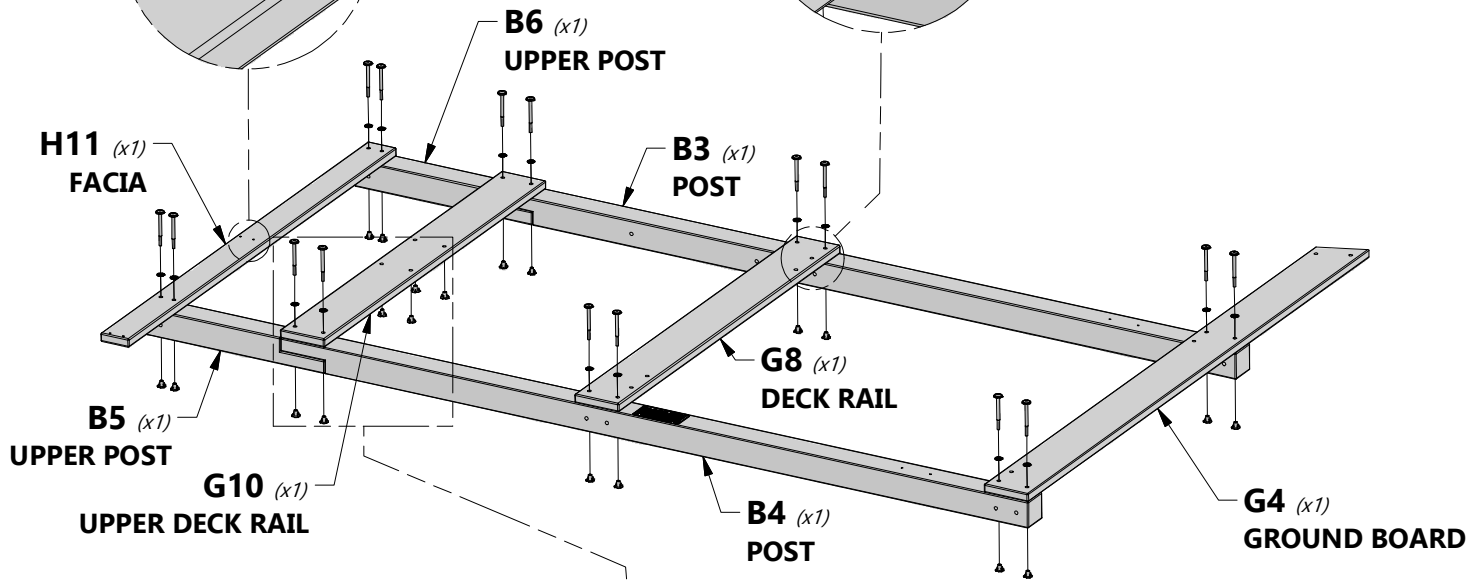
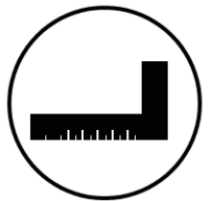
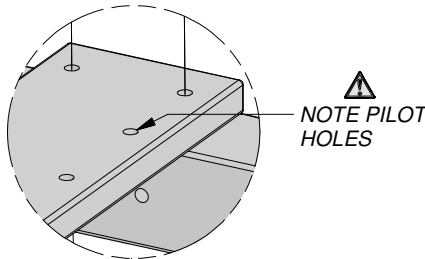
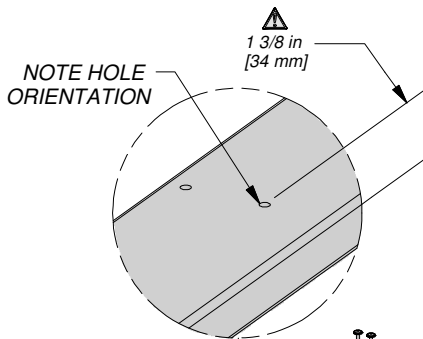
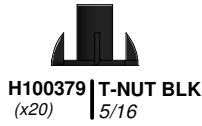
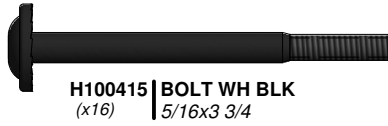

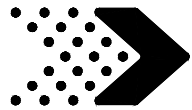

Phase 1

STEP 2

B6 | UPPER POST - W4L12428
(x1) | 3"x3"x21 1/4" (76x76x541)

B1 | POST - W4L12286
(x1) | 3"x3"x89 1/2" (76x76x2274)

H12 | FACIA - W4L12400
(x1) | 1"x3 3/8"x56 3/4" (24x86x1440)

1 3/8 in [34 mm]

B5 | UPPER POST - W4L12397
(x1) | 3"x3"x21 1/4" (76x76x541)

B2 | POST - W4L12287
(x1) | 3"x3"x89 1/2" (76x76x2274)

G6 | DECK RAIL - W4L12295
(x1) | 1"x5 1/4"x47" (24x134x1194)

9 1/2 in [241 mm]

THESE HOLES UP

G2 | GROUND BOARD - W4L12291
(x1) | 1"x5 1/4"x72 1/4" (24x134x1835)

H100415 | BOLT WH BLK
(x12) | 5/16x3 3/4

H100416 | BOLT WH BLK
(x4) | 5/16x3

H100198 | WASHER LOCK EXT BLK
(x16) | 8x19

H100379 | T-NUT BLK
(x16) | 5/16

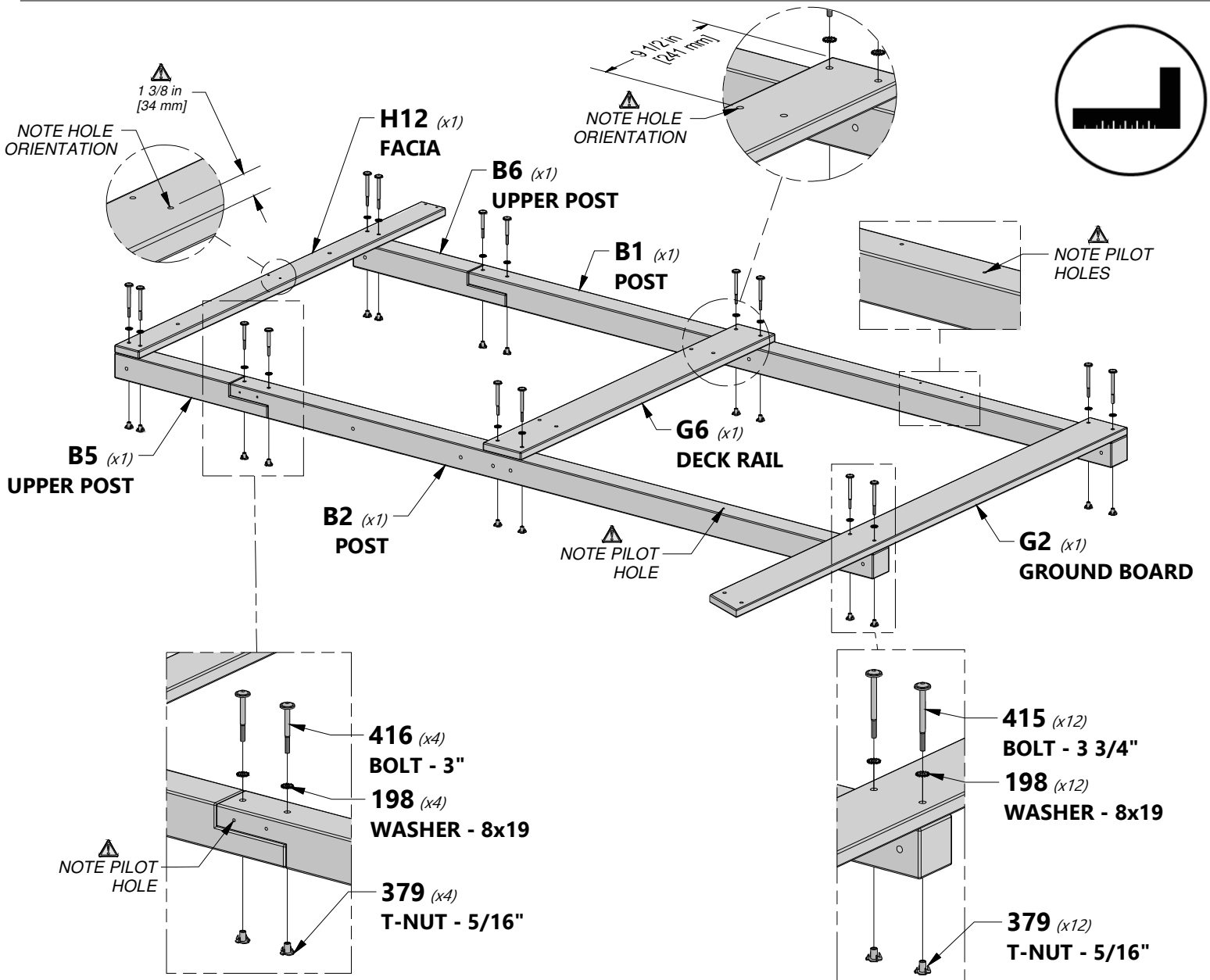

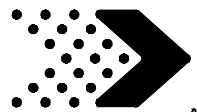

Phase 1

STEP 3

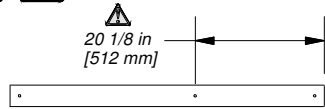

H9 | **FACIA - W4L12402**
(x1) | 1"x3 3/8"x49 1/8" (24x86x1248)



G1 | **GROUND BOARD - W4L12290**
(x1) | 1"x5 1/4"x70 3/4" (24x134x1798)

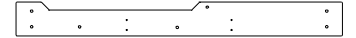

G5 | **DECK RAIL - W4L12294**
(x1) | 1"x5 1/4"x51" (24x134x1296)



H100415 | **BOLT WH BLK**
(x10) | 5/16x3 3/4



H100379 | **T-NUT BLK**
(x10) | 5/16



H100198 | **WASHER LOCK EXT BLK**
(x10) | 8x19

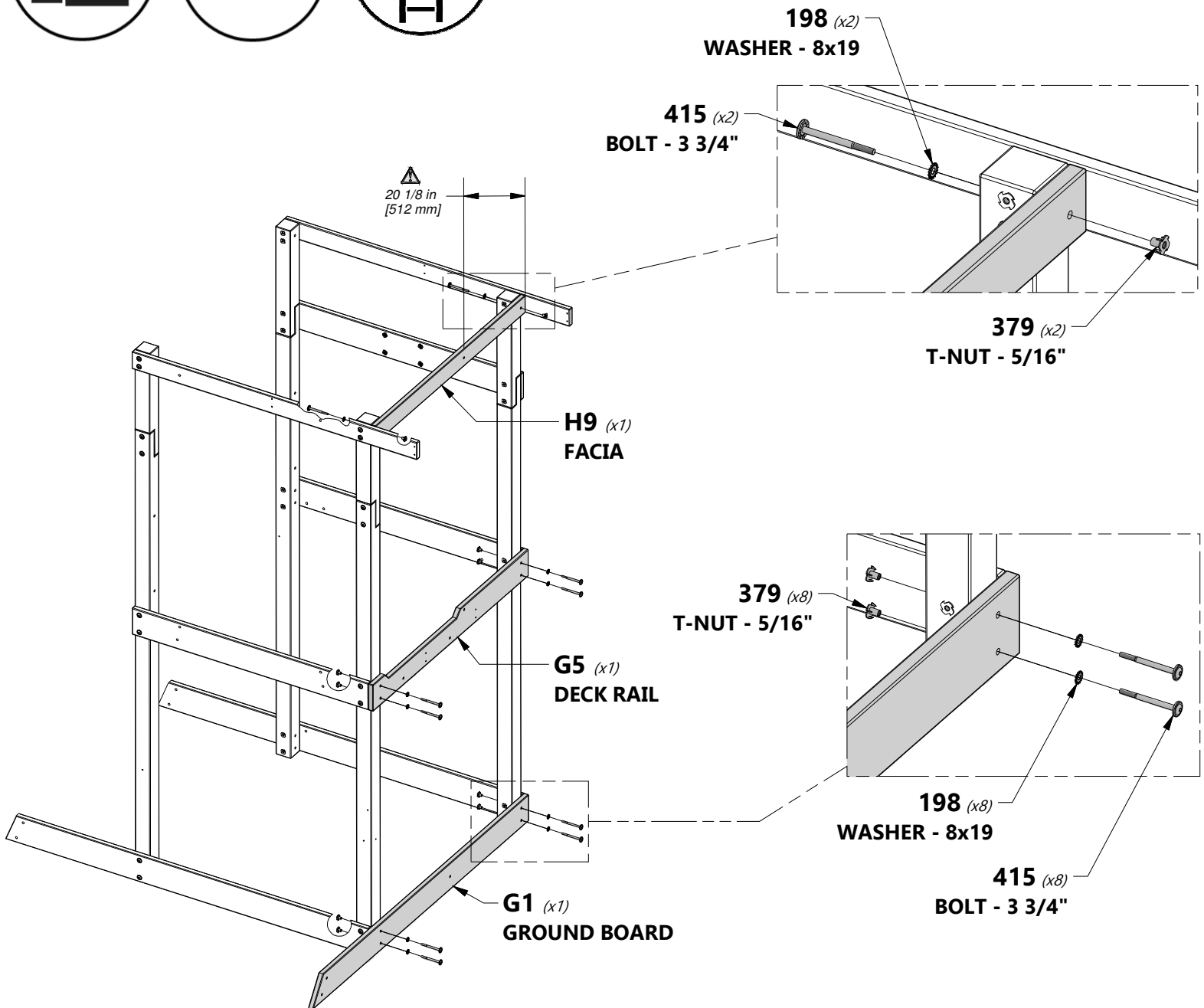
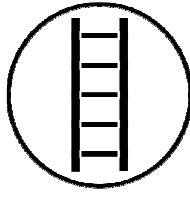
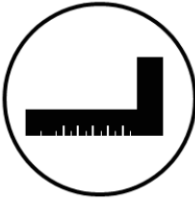

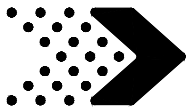

Phase 1

STEP 4

G9 | UPPER DECK RAIL - W4L12299
 (x1) | 1"x5 1/4"x50 1/8" (24x134x1272)

G7 | DECK RAIL - W4L12296
 (x1) | 1"x5 1/4"x51" (24x134x1296)

G3 | GROUND BOARD - W4L12292
 (x1) | 1"x5 1/4"x49 1/8" (24x134x1248)

H100503 | BOLT WH BLK
 (x4) | 5/16x3-1/2

H100197 | LAG SCREW WH BLK
 (x4) | 5/16x2 1/2

H100198 | WASHER LOCK EXT BLK
 (x12) | 8x19

H100415 | BOLT WH BLK
 (x4) | 5/16x3 3/4

H100379 | T-NUT BLK
 (x8) | 5/16

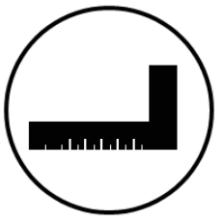

NOTE: FACE COUNTER BORE OUTWARDS

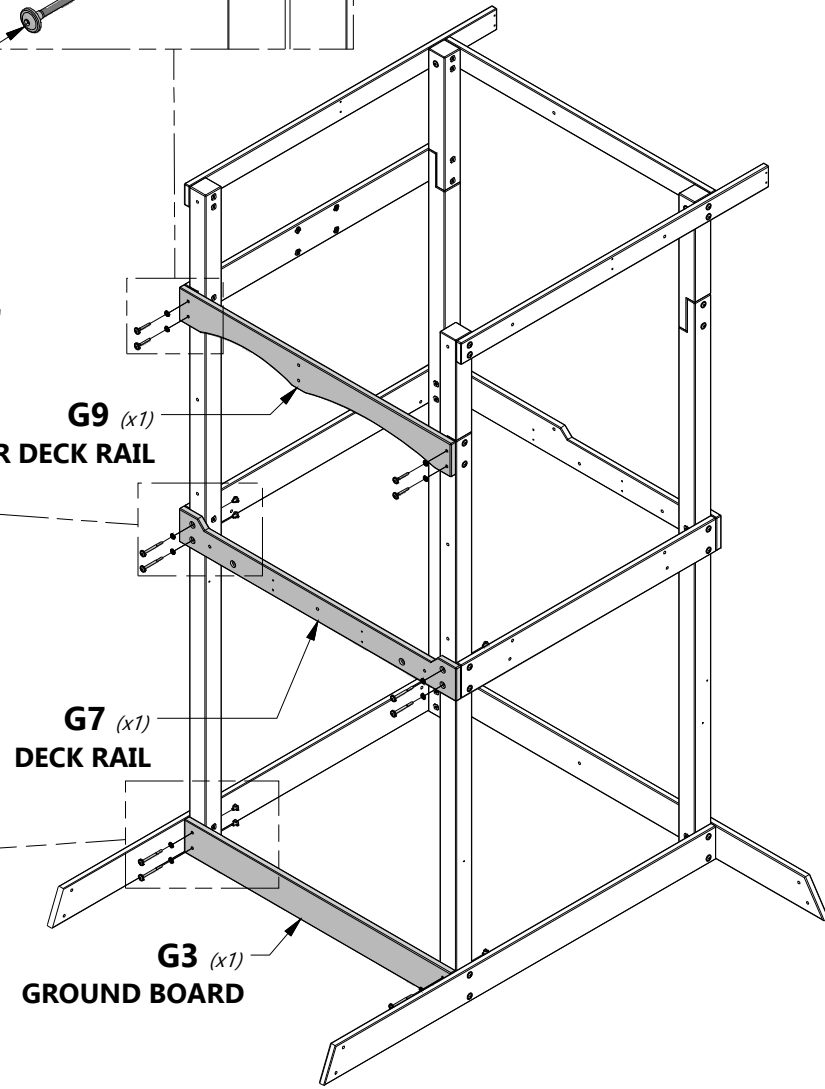
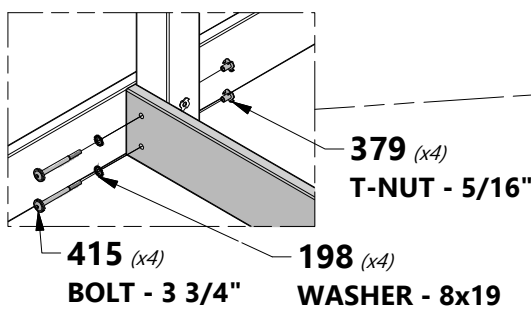
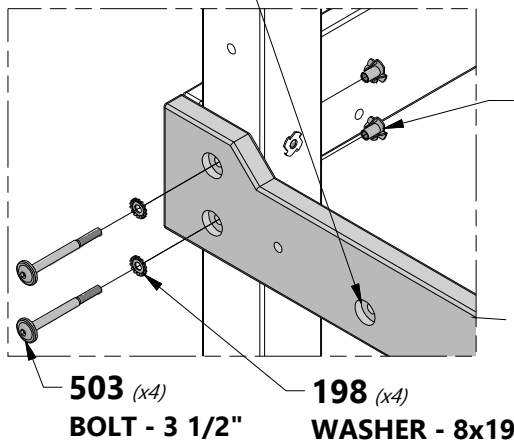
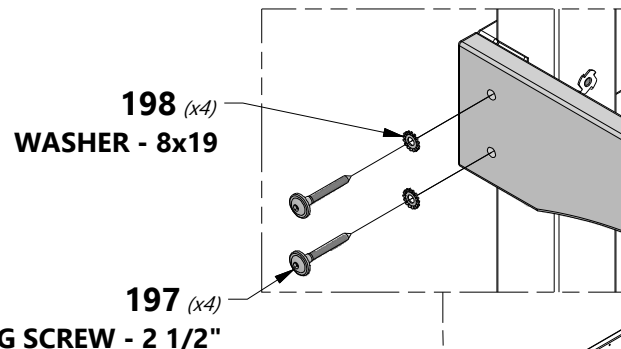

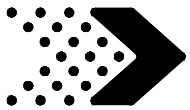

Phase 1

STEP 5

H13 | **FACIA - W4L12427**
 (x1) | 1"x3 3/8"x49 1/8" (24x86x1248)

H100201 | **SCREW PFH BLK**
 (x4) | 8x2-1/2"

H100379 | **T-NUT BLK**
 (x2) | 5/16"

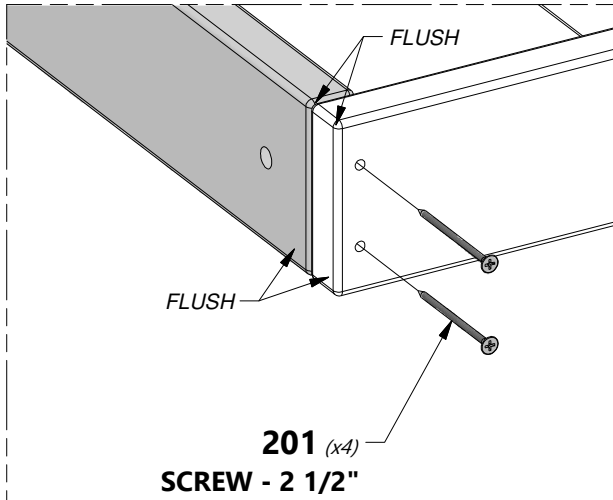
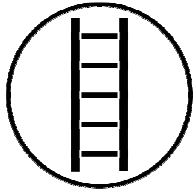

H13 (x1)
FACIA

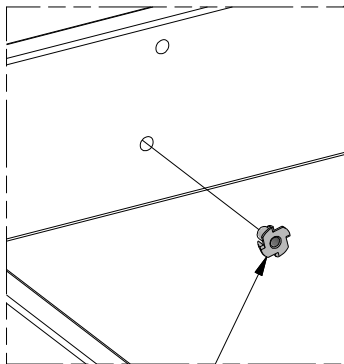
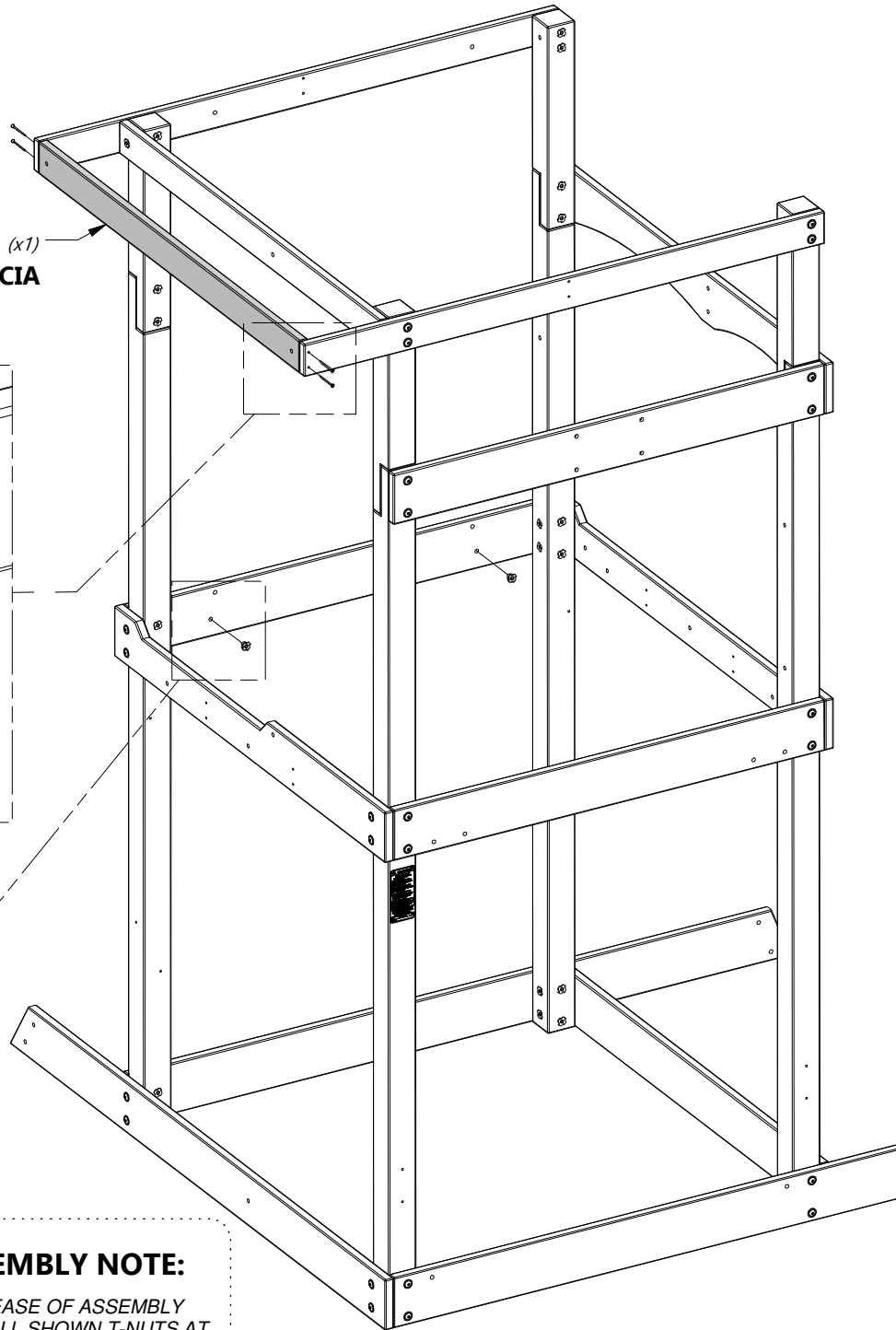

ASSEMBLY NOTE:
 FOR EASE OF ASSEMBLY
 INSTALL SHOWN T-NUTS AT
 THIS TIME. NOTE THESE
 WILL BE USED IN A LATER
 STEP.

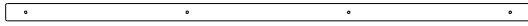
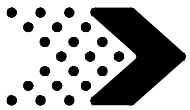

T1 | **DECK SUPPORT - W4L12308**
(x2) | 1"x1 3/8"x41" (24x34x1040)



T2 | **DECK SUPPORT - W4L12311**
(x4) | 1"x1 3/8"x3" (24x34x76)



H100200 | **SCREW PFH BLK**
(x16) | 8x1 1/2



ASSEMBLY NOTE:

REPEAT THIS ON
BOTH SIDES AS
SHOWN

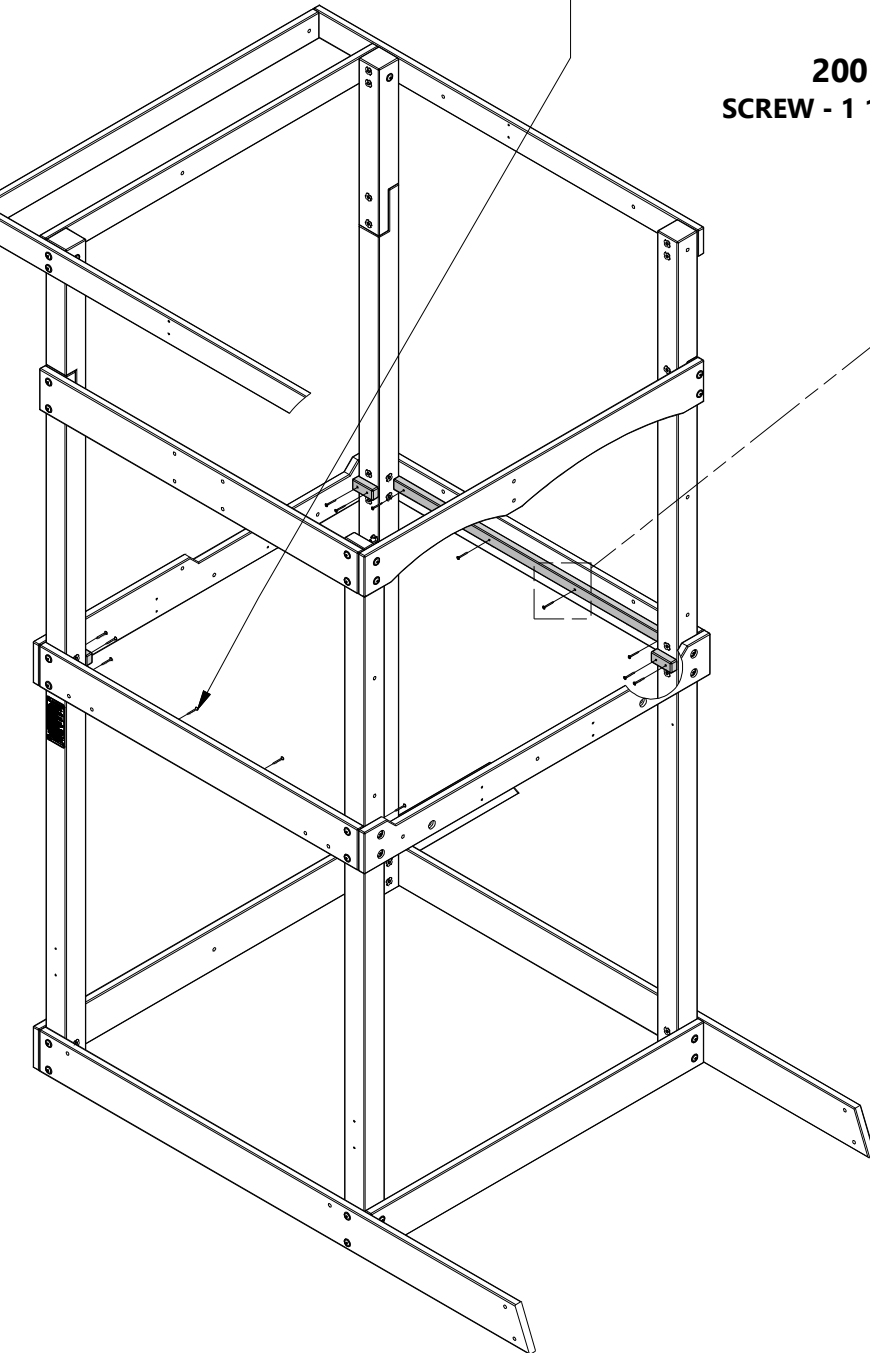

200 (x16)
SCREW - 1 1/2"

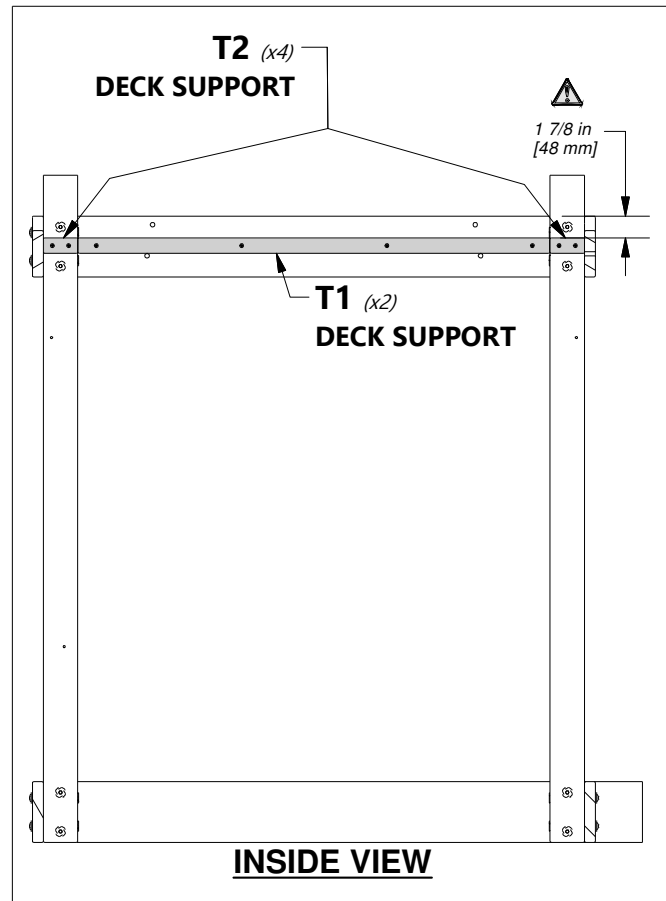
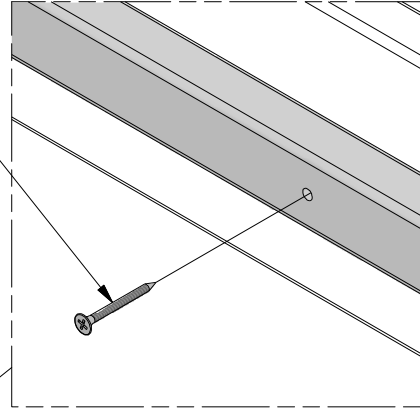

INSIDE VIEW

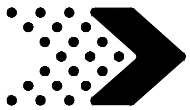

Phase 1

STEP 7



E1 | **BRACE - W4L12312**
(x3) | 1 3/8"x3 3/8"x13 5/8" (36x86x347)

H100197 | **LAG SCREW WH BLK**
(x3) | 5/16x2 1/2

H100457 | **BOLT WH BLK**
(x2) | 5/16x2



H100198 | **WASHER LOCK EXT BLK**
(x6) | 8x19

H100205 | **BOLT WH BLK**
(x1) | 5/16x2-1/4

H100379 | **T-NUT BLK**
(x3) | 5/16

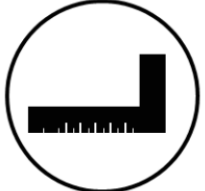
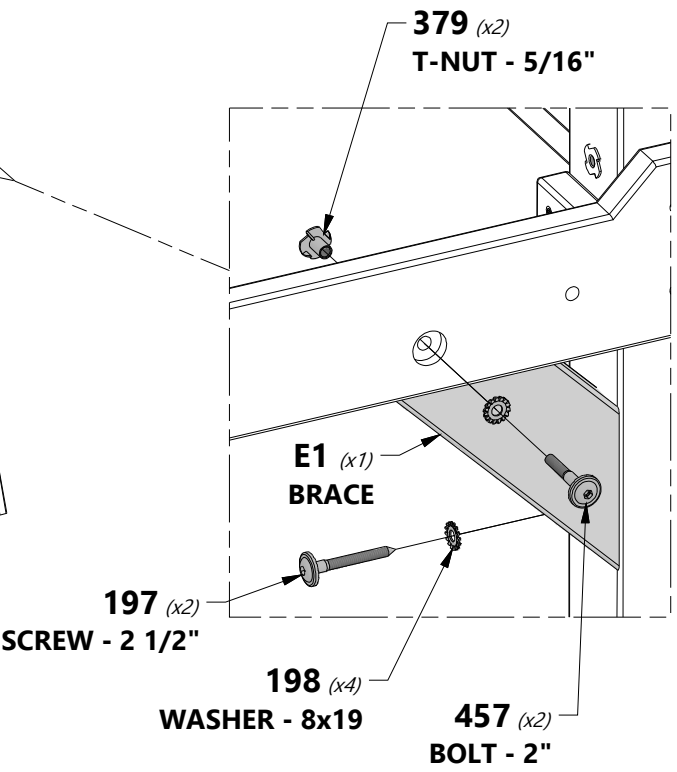
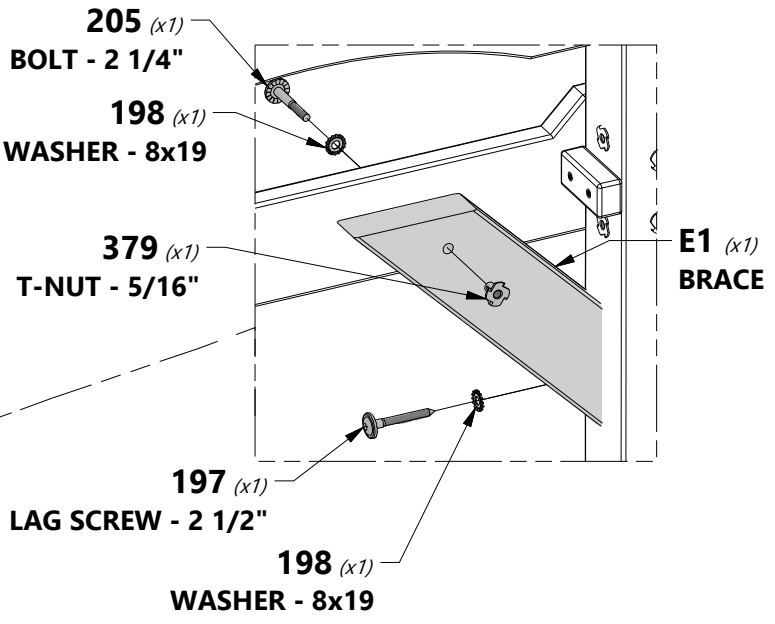
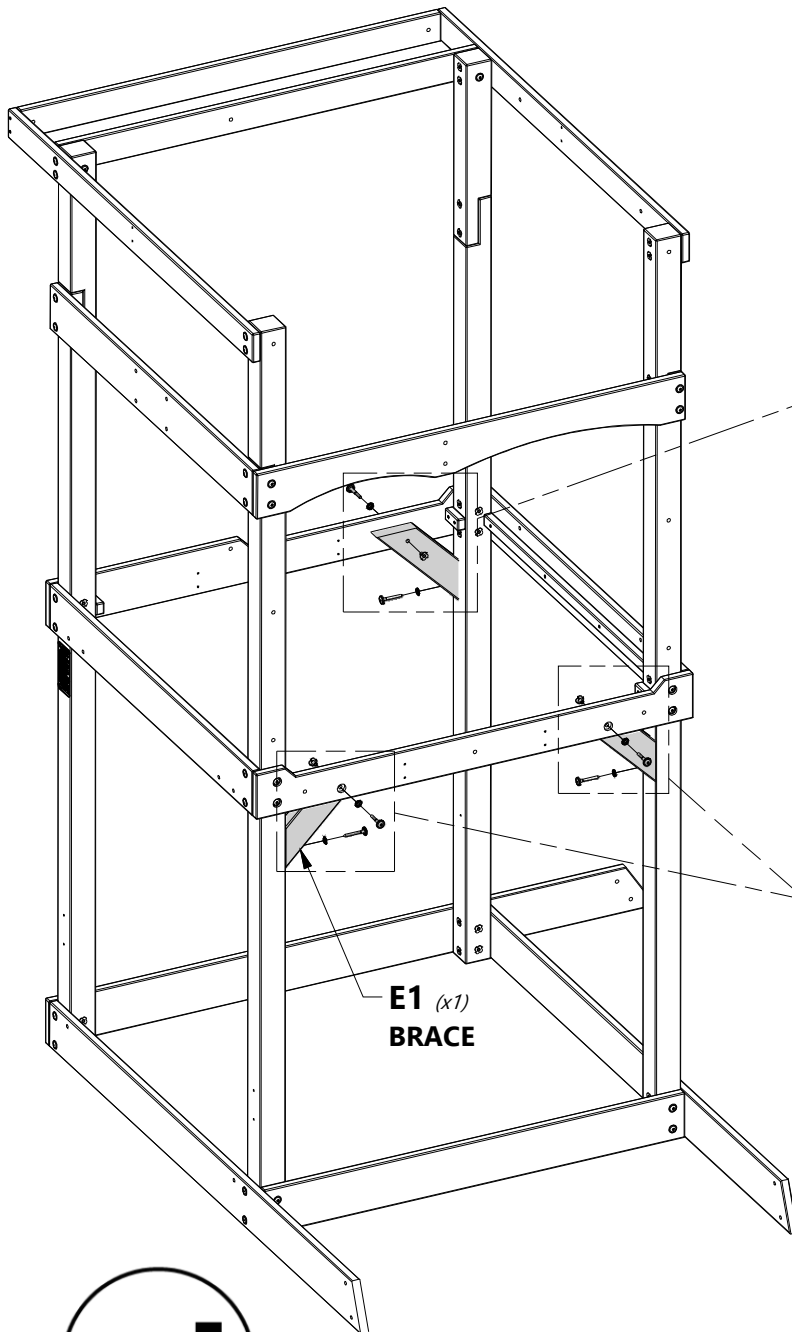

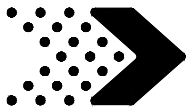

Phase 1

STEP 8



H1 | **DECK SUPPORT - W4L12306**
(x2) | 1"x3 3/8"x47" (24x86x1194)



H100201 | **SCREW PFH BLK**
(x8) | 8x2-1/2

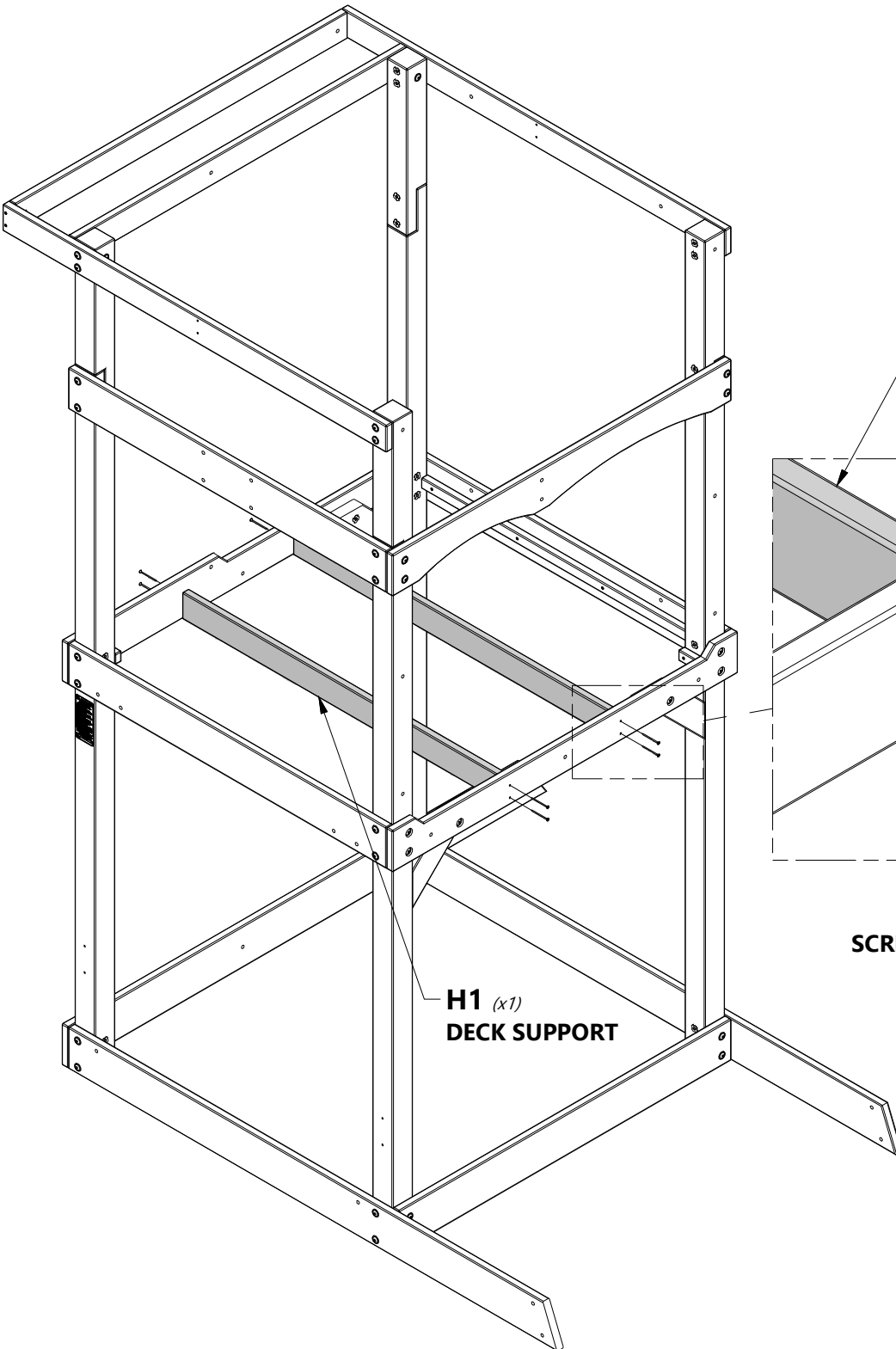

H1 (x1)
DECK SUPPORT

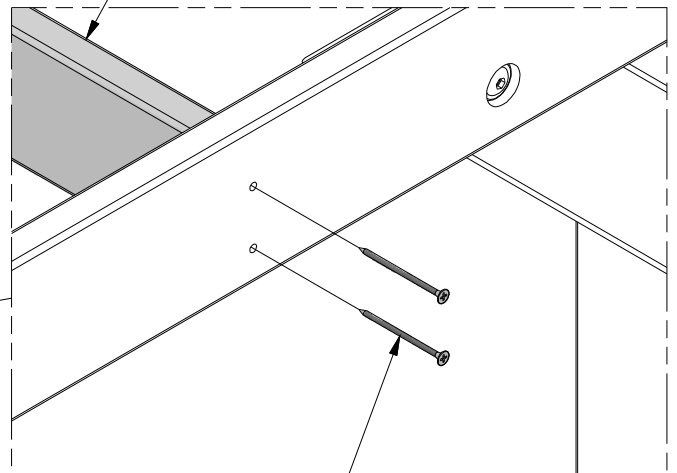

201 (x8)
SCREW - 2 1/2"

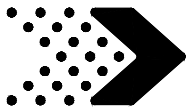

Phase 1

STEP 9

G12 | CROSS SUPPORT - W4L12315
(x1) | 1"x5 1/4"x65 1/4" (24x134x1658)

G13 | CROSS SUPPORT - W4L12314
(x1) | 1"x5 1/4"x65 1/4" (24x134x1658)

H100378 | BOLT WH BLK
(x6) | 5/16x1 3/4

H100468 | BOLT WH BLK
(x1) | 5/16x1

H100379 | T-NUT BLK
(x7) | 5/16

H100198 | WASHER LOCK EXT BLK
(x7) | 8x19

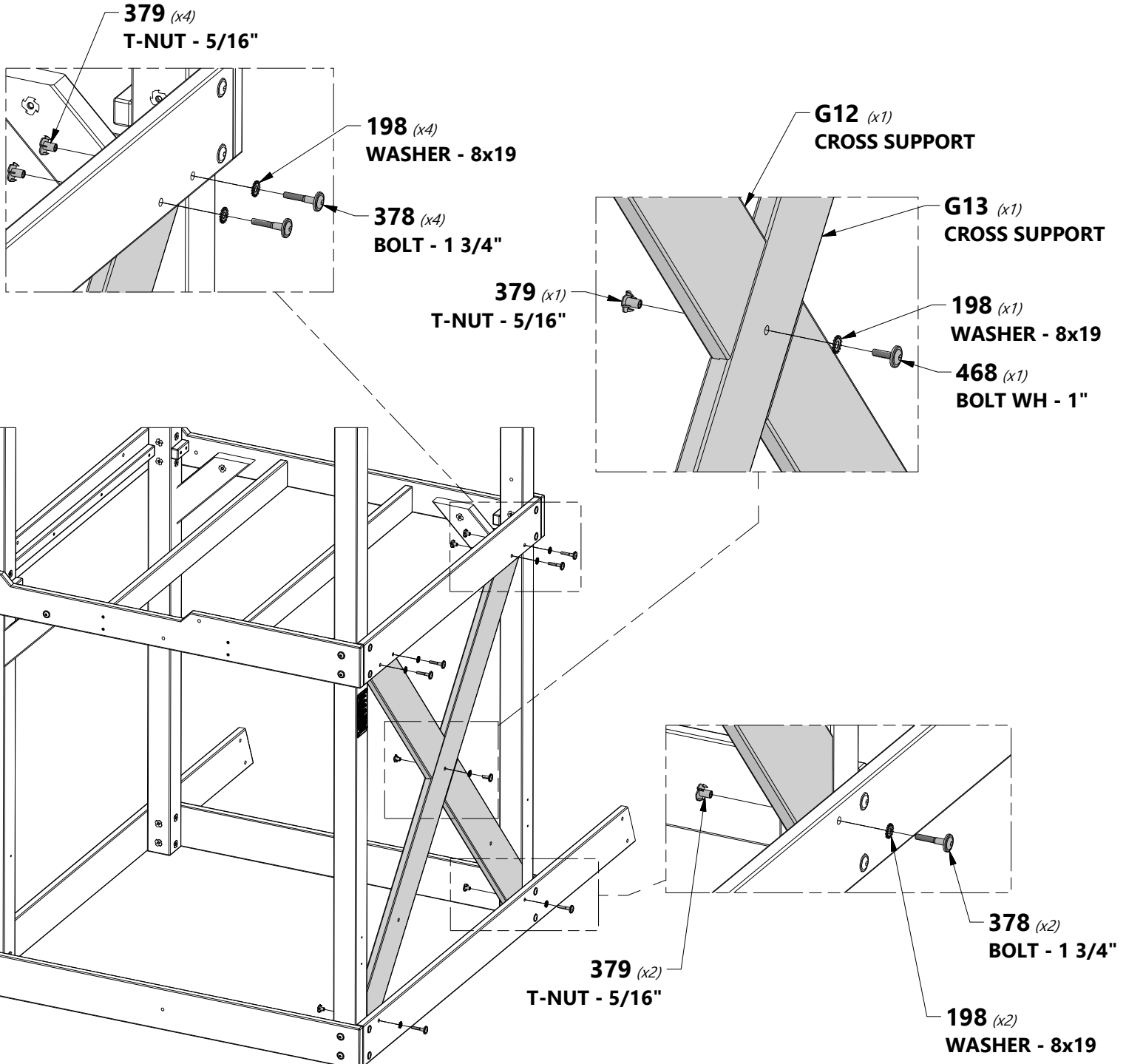

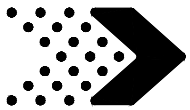

Phase 1

STEP 10



G17 | **CROSS BRACE - W4L12966**
(x2) | 1"x5 1/4"x17" (24x134x430)



H100197 | **LAG SCREW WH BLK**
(x4) | 5/16x2 1/2



H100378 | **BOLT WH BLK**
(x2) | 5/16x1 3/4



H100379 | **T-NUT BLK**
(x2) | 5/16



H100198 | **WASHER LOCK EXT BLK**
(x6) | 8x19

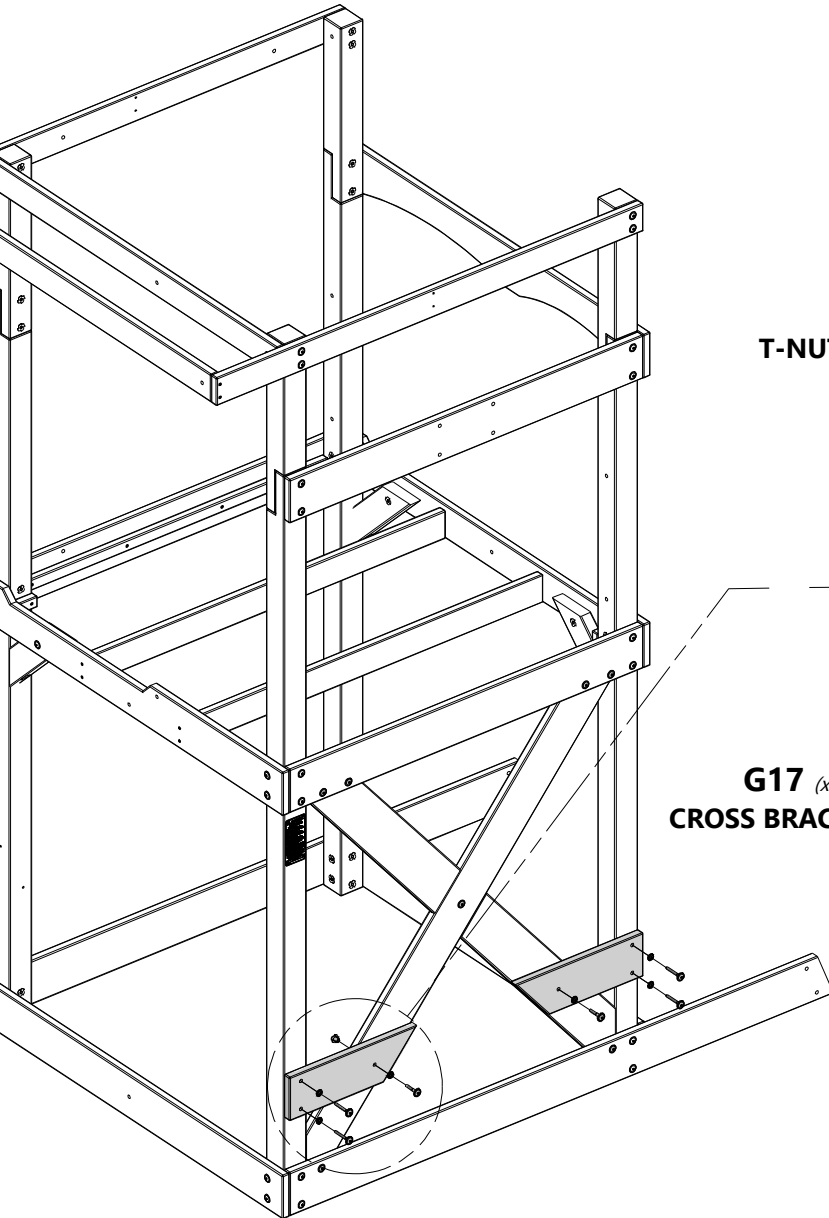

379 (x2)
T-NUT - 5/16"

198 (x2)
WASHER - 8x19

378 (x2)
BOLT - 1 3/4"

G17 (x2)
CROSS BRACE

197 (x4)
LAG SCREW - 2 1/2"

198 (x4)
WASHER - 8x19

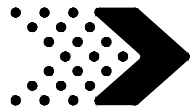

Phase 1

STEP 11

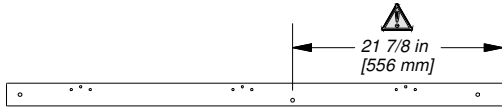

J1
(x1) | **WALL UPRIGHT - W4L12303**
1"x2 3/8"x51 3/4" (24x60x1314)

H100407 | **BOLT WH BLK**
(x2) | 5/16x1 1/2

H100192 | **NUT BARREL WH BLK**
(x2) | 5/16x7/8

H100199 | **WASHER LOCK EXT BLK**
(x2) | 12x19

H100198 | **WASHER LOCK EXT BLK**
(x2) | 8x19

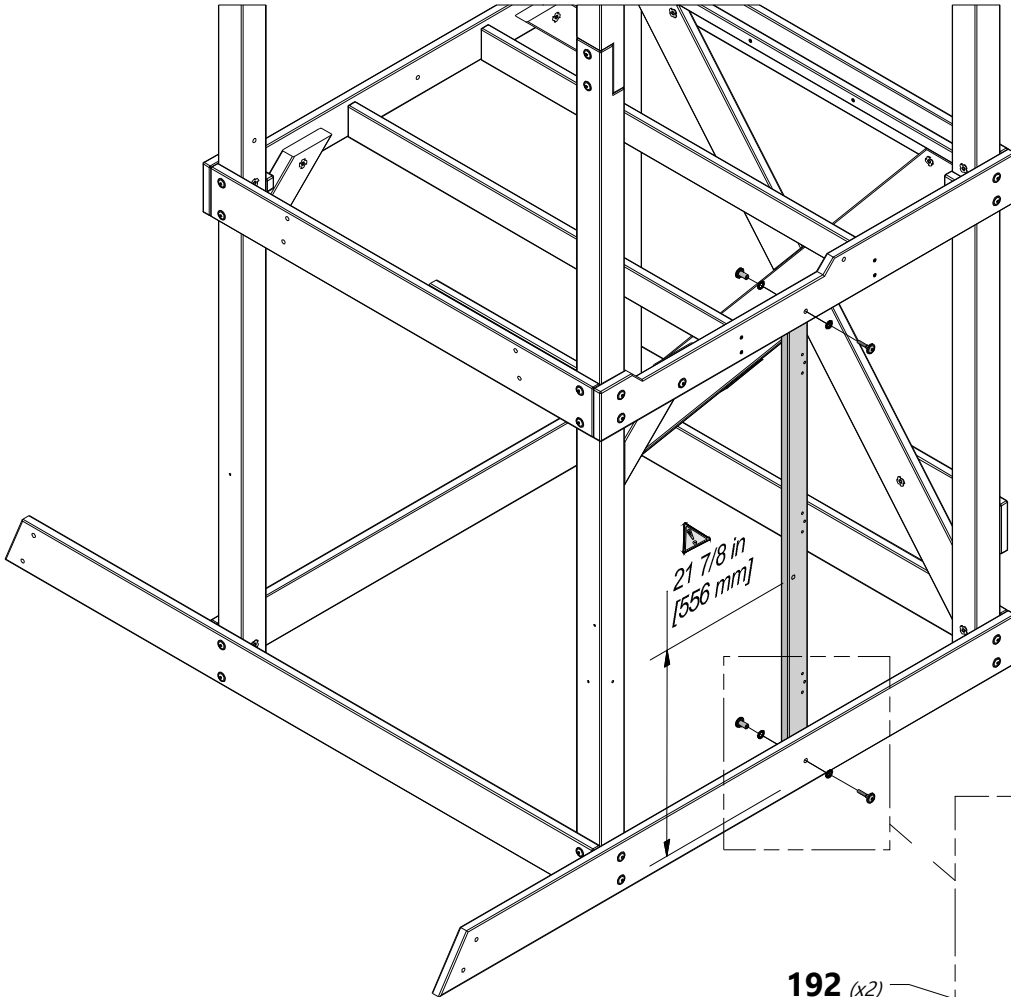

 **ASSEMBLY NOTE:**
INSTALL J1 BOARD WITH
HINGE HOLES FACING
RIGHT AS SHOWN.

192 (x2)
NUT BARREL - 7/8"

199 (x2)
WASHER - 12x19

198 (x2)
WASHER - 8x19

407 (x2)
BOLT - 1 1/2"

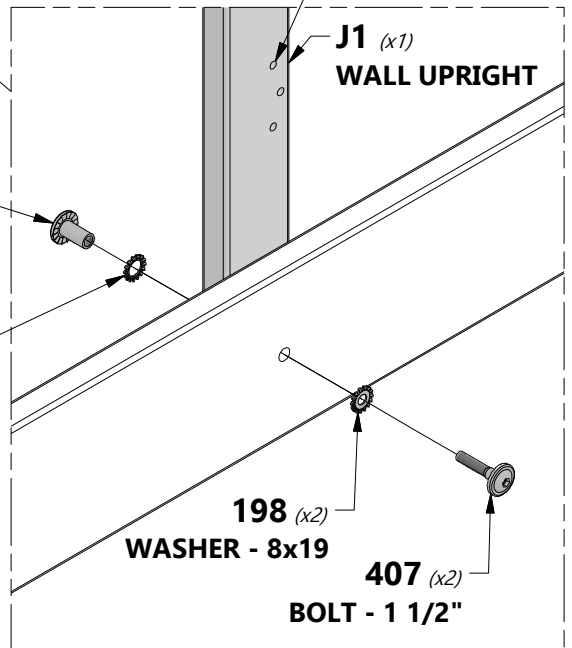

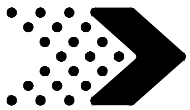

Phase 1

STEP 12



M6 | LOWER RAIL - W4L12304
(x1) | 5/8"x3 3/8"x47" (16x86x1194)



H100458 | LAG SCREW WH BLK
(x2) | 5/16x2



H100198 | WASHER LOCK EXT BLK
(x2) | 8x19

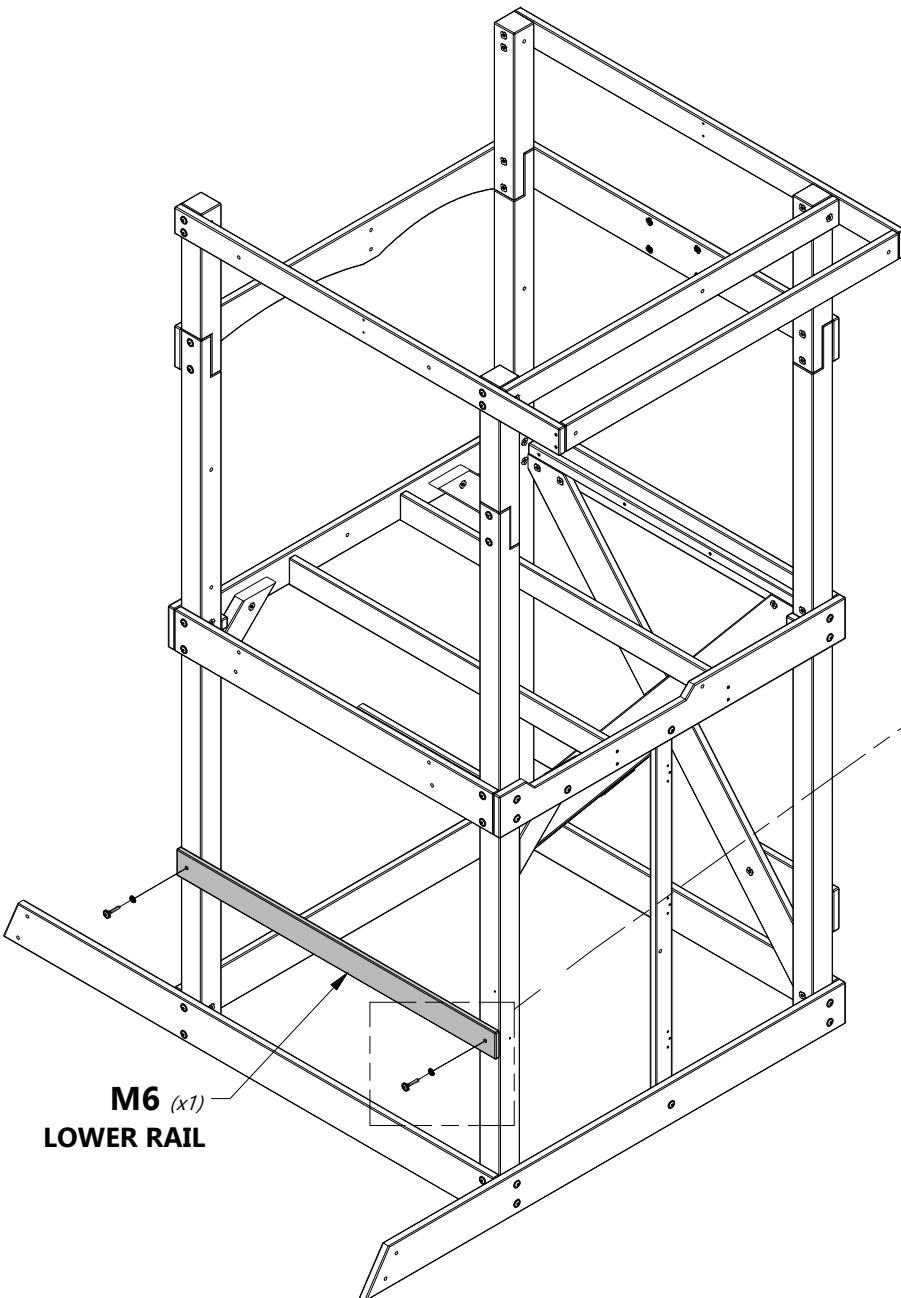

M6 (x1)
LOWER RAIL

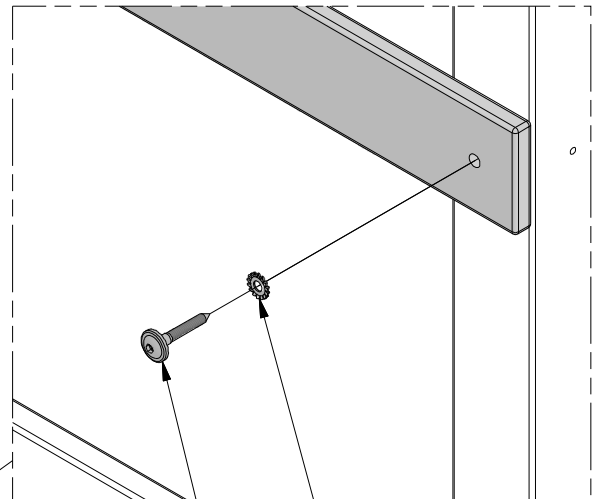

198 (x2)
WASHER - 8x19

458 (x2)
LAG SCREW - 2"

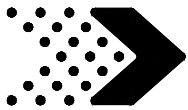

Phase 1

STEP 13



E3 | **BRACE - W4L12500**
(x1) | 1 3/8"x3 3/8"x37 3/4" (36x86x959)



H100197 | **LAG SCREW WH BLK**
(x1) | 5/16x2 1/2



H100198 | **WASHER LOCK EXT BLK**
(x3) | 8x19



H100205 | **BOLT WH BLK**
(x2) | 5/16x2-1/4



H100379 | **T-NUT BLK**
(x2) | 5/16

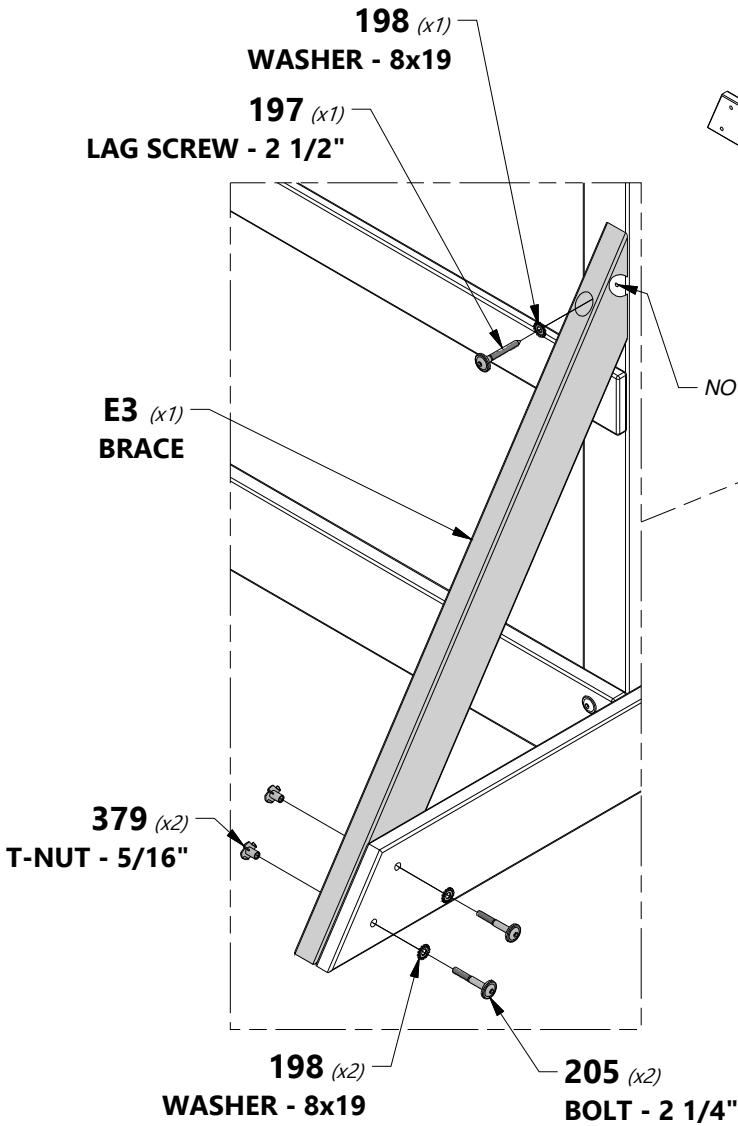
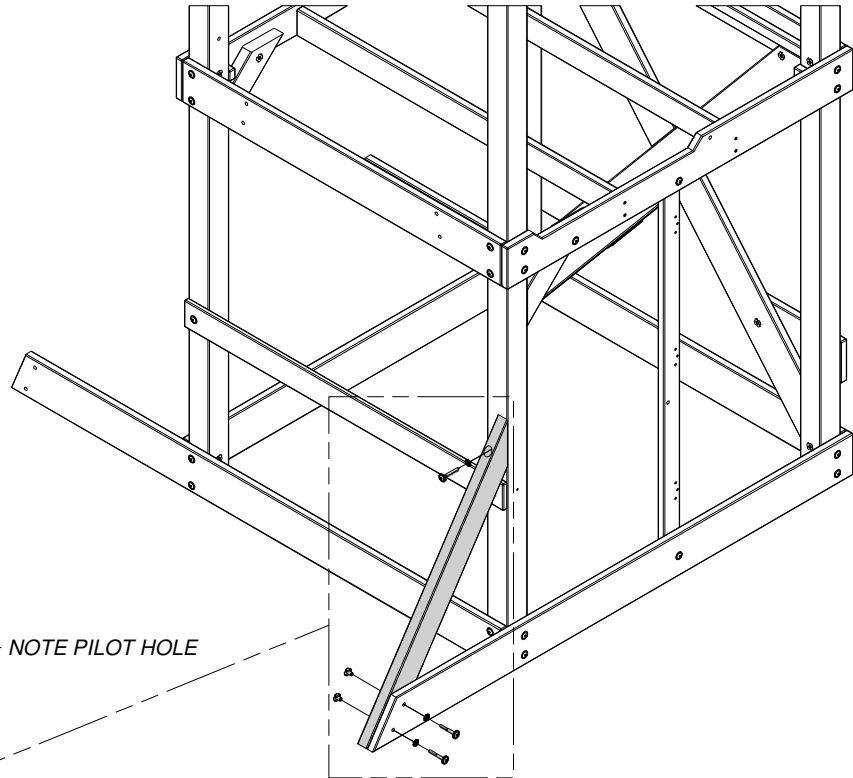
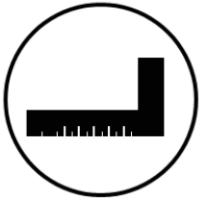



Phase 1

STEP 14

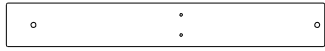

M5 | LOWER RAIL - W4L12305
(x1) | 5/8"x3 3/8"x24 7/8" (16x86x632)



H15 | COUNTER SUPPORT - W4L12424
(x1) | 1"x3 3/8"x3 3/4" (24x86x94)



H100200 | SCREW PFH BLK
(x2) | 8x1 1/2



H100458 | LAG SCREW WH BLK
(x1) | 5/16x2



H100468 | BOLT WH BLK
(x1) | 5/16x1

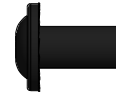

H100192 | NUT BARREL WH BLK
(x1) | 5/16x7/8



H100198 | WASHER LOCK EXT BLK
(x2) | 8x19



H100199 | WASHER LOCK EXT BLK
(x1) | 12x19

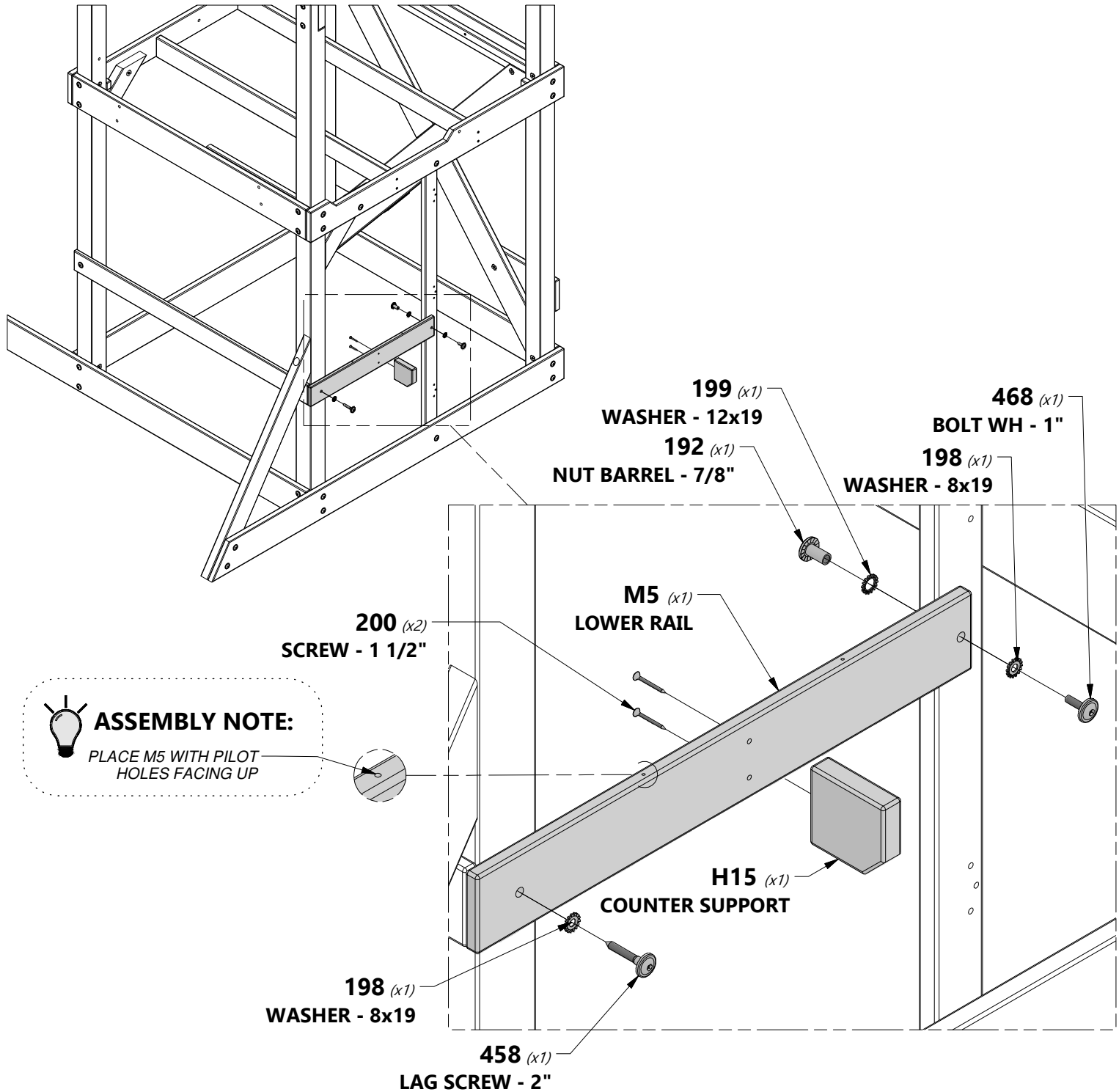

ASSEMBLY NOTE:

PLACE M5 WITH PILOT HOLES FACING UP

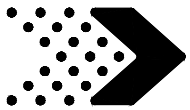

Phase 1

STEP 15



M7 | PICKET - W4L12316
(x3) | 5/8"x3 3/8"x21" (16x86x533)



M9 | PICKET - W4L12317
(x1) | 5/8"x2 7/8"x21" (16x74x533)



M10 | PICKET - W4L12323
(x2) | 5/8"x3 3/8"x21" (16x86x533)



H100380 | SCREW PFH BLK
(x24) | 8x1 1/8

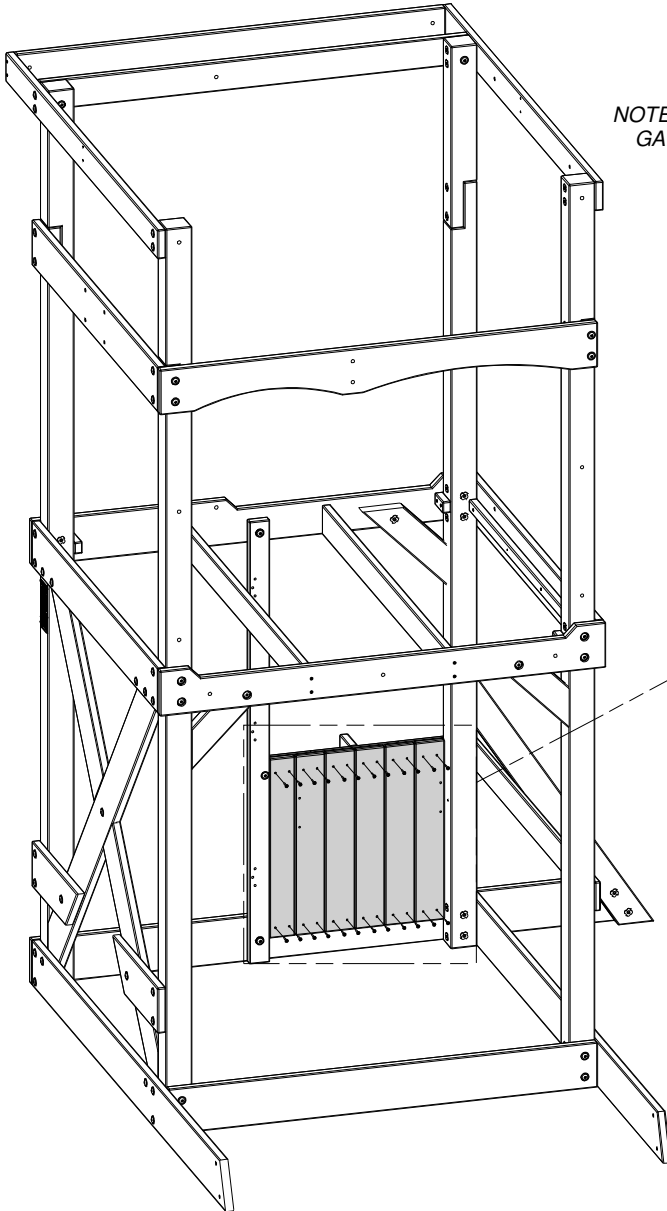

NOTE: EVENLY SPACE ANY GAPS BETWEEN BOARDS.

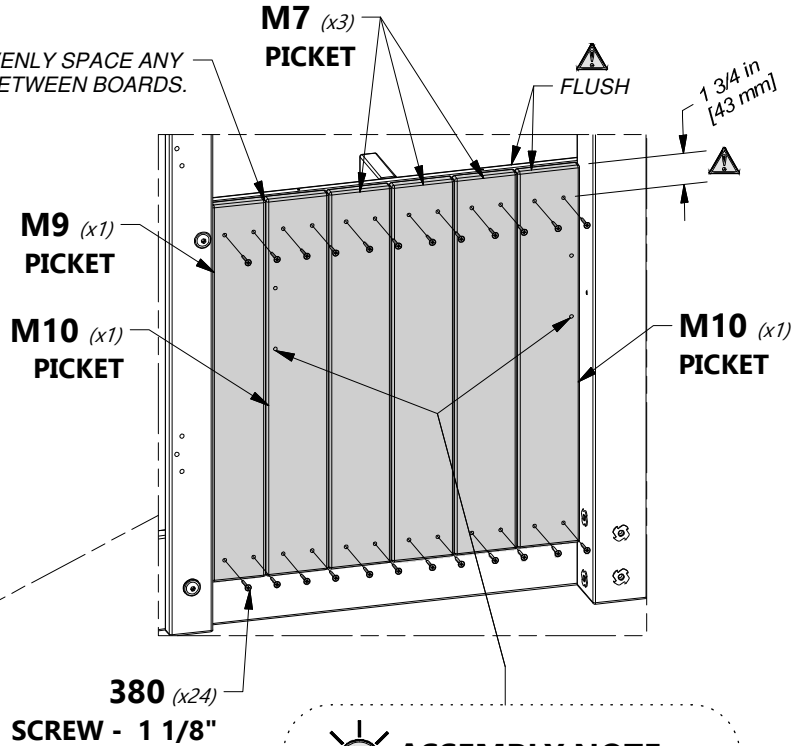

ASSEMBLY NOTE:
NOTE HOLE LOCATIONS AND BOARD ORIENTATION ON M10 BOARDS.

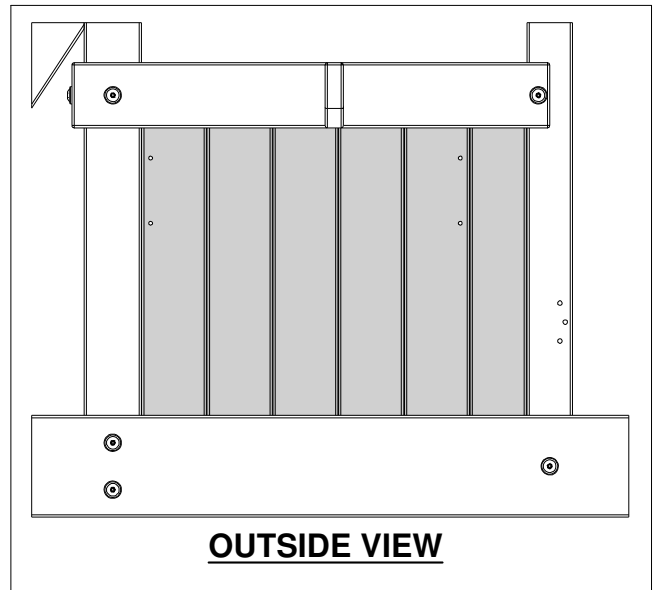

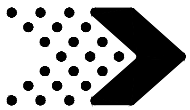

Phase 1

STEP 16

M7
(x4) **PICKET - W4L12316**
5/8"x3 3/8"x21" (16x86x533)

M8
(x2) **PICKET - W4L12395**
5/8"x3 3/8"x21" (16x86x533)

H100380 | **SCREW PFH BLK**
(x24) | 8x1 1/8

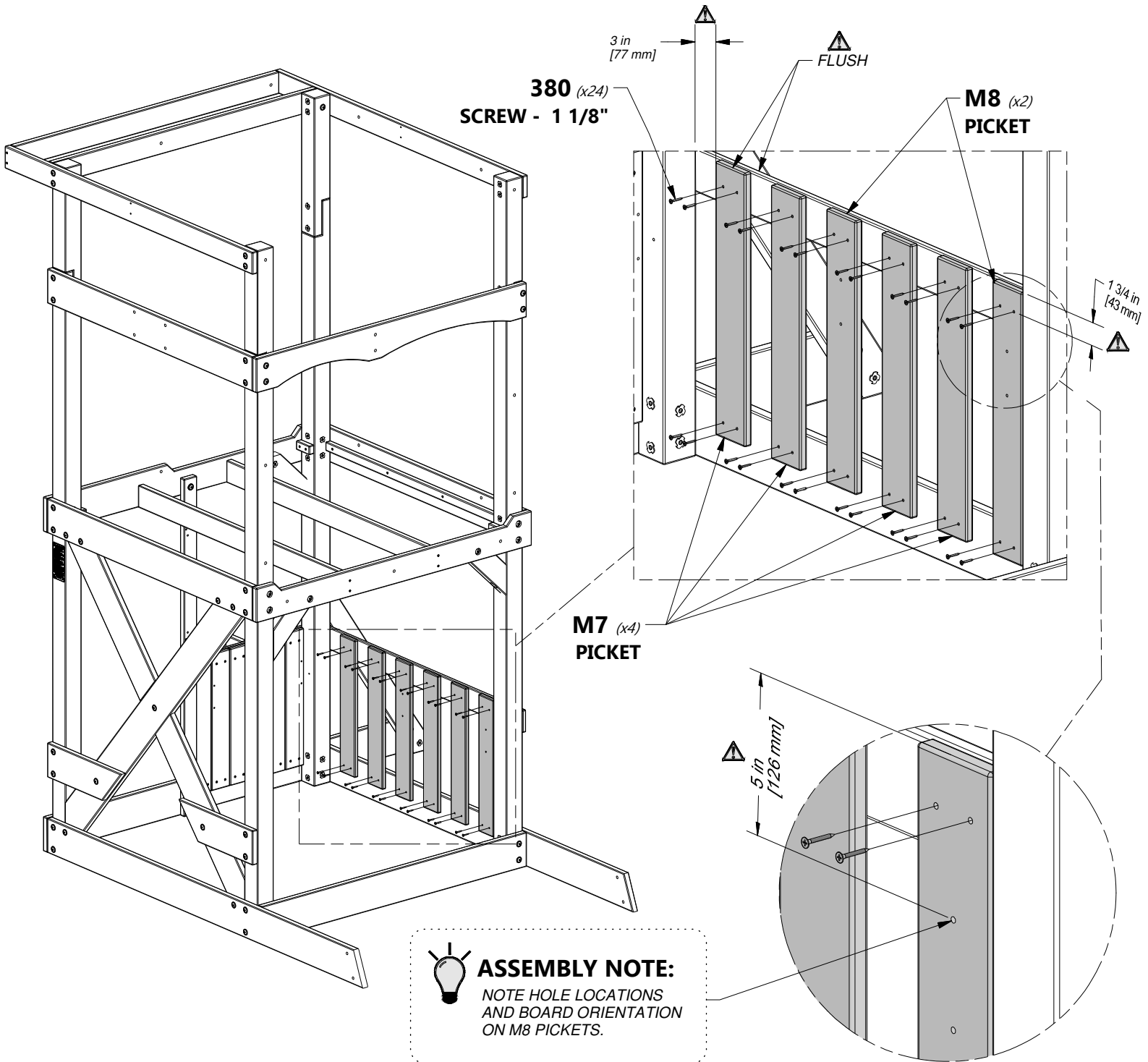



Phase 1

STEP 17

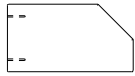

G14 | COUNTER TOP SUPPORT - W4L12322
(x3) | 1"x5 1/4"x9 7/8" (24x134x250)

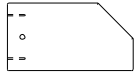

G15 | COUNTER TOP SUPPORT - W4L12425
(x1) | 1"x5 1/4"x9 7/8" (24x134x250)



H100197 | LAG SCREW WH BLK
(x1) | 5/16x2 1/2



H100198 | WASHER LOCK EXT BLK
(x1) | 8x19



H100391 | SCREW PFH BLK
(x8) | 8x2

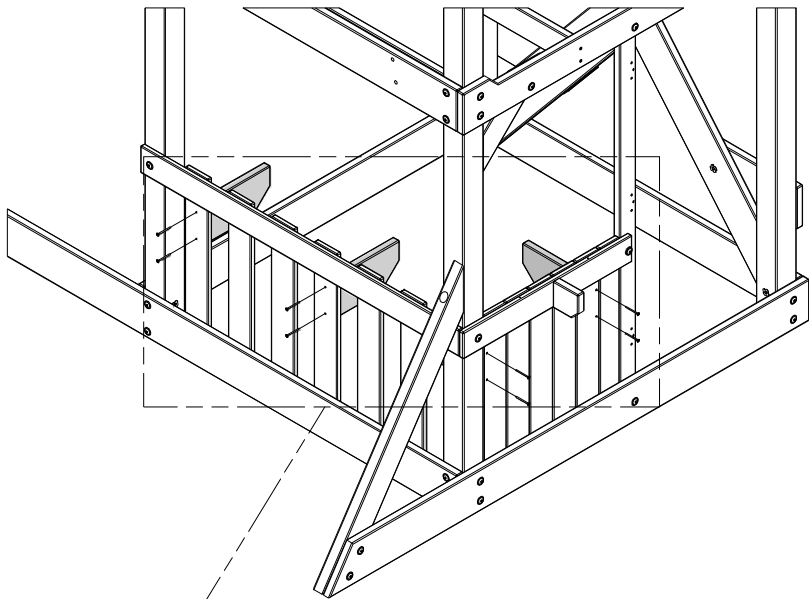

G14 (x3)
COUNTER TOP SUPPORT

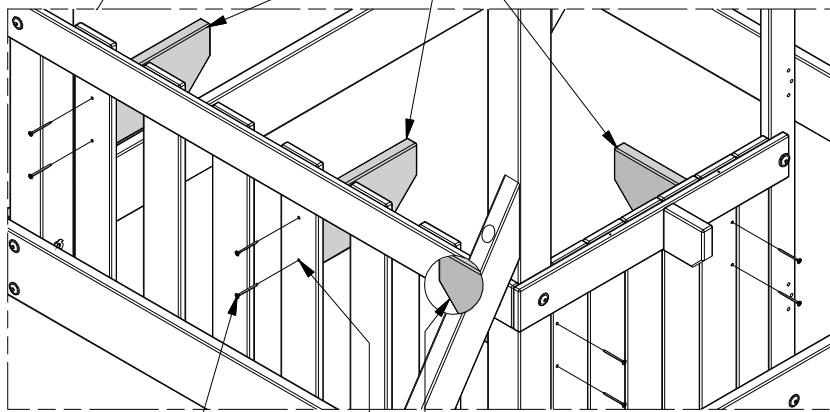

391 (x8)
SCREW - 2"

G15 FROM INSIDE VIEW



ASSEMBLY NOTE:
USE THE PILOT HOLES TO
INSTALL THE COUNTER
SUPPORTS.

INSIDE VIEW

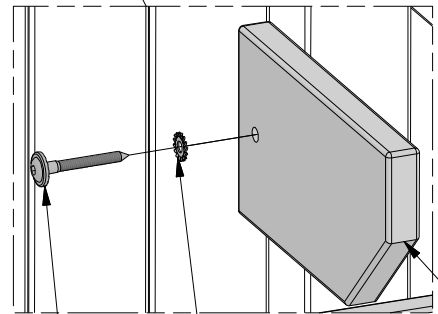
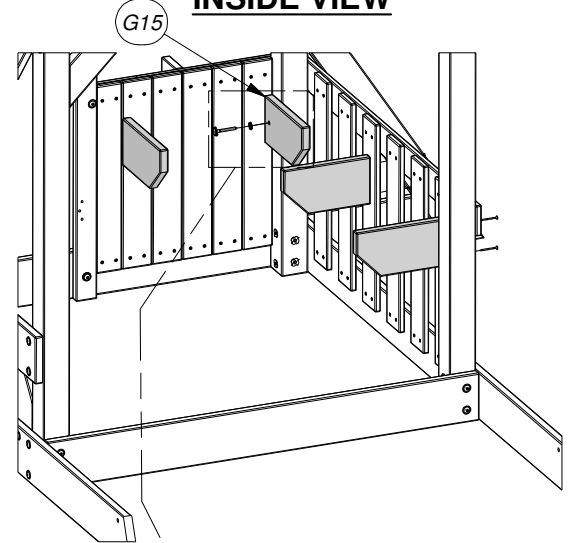

198 (x1)
WASHER - 8x19

197 (x1)
LAG SCREW - 2 1/2"

G15 (x1)
COUNTER TOP SUPPORT

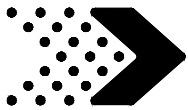

Phase 1

STEP 18

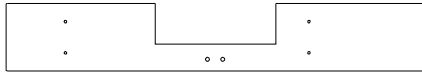

K5 | COUNTER TOP - W4L12320
(x1) | 5/8"x5 1/4"x32 3/4" (16x134x832)



K6 | COUNTER TOP - W4L12321
(x1) | 5/8"x5 1/4"x32 3/4" (16x134x832)



K3 | COUNTER TOP - W4L12318
(x1) | 5/8"x5 1/4"x23 5/8" (16x134x600)



K4 | COUNTER TOP - W4L12319
(x1) | 5/8"x5 1/4"x23 5/8" (16x134x600)



H100200 | SCREW PFH BLK
(x16) | 8x1 1/2

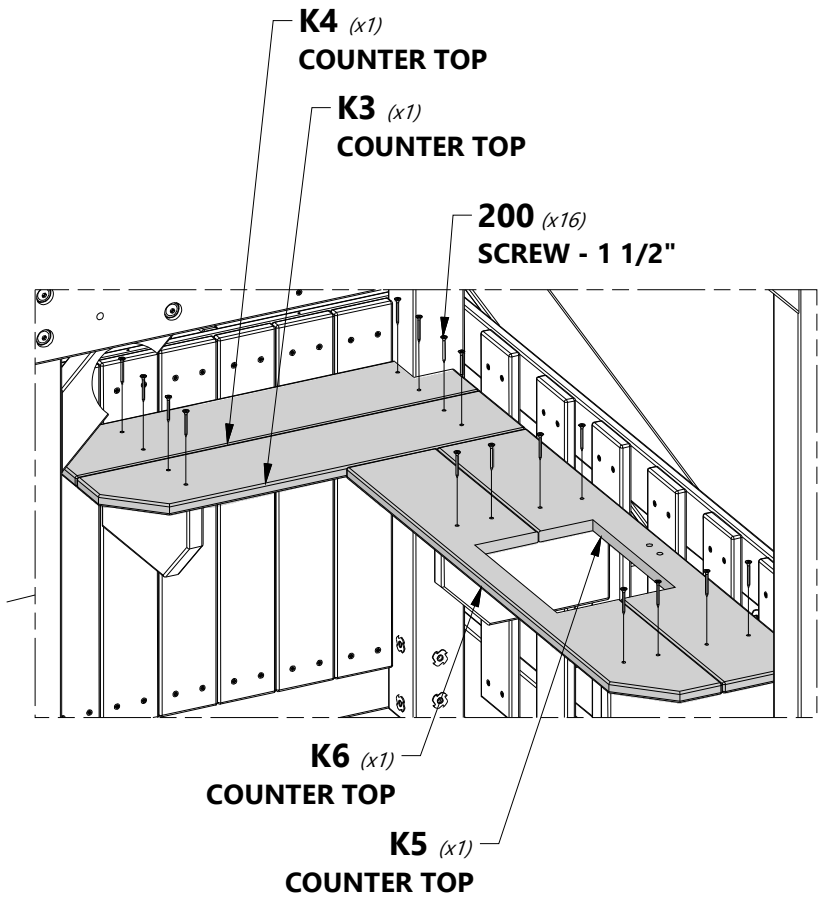
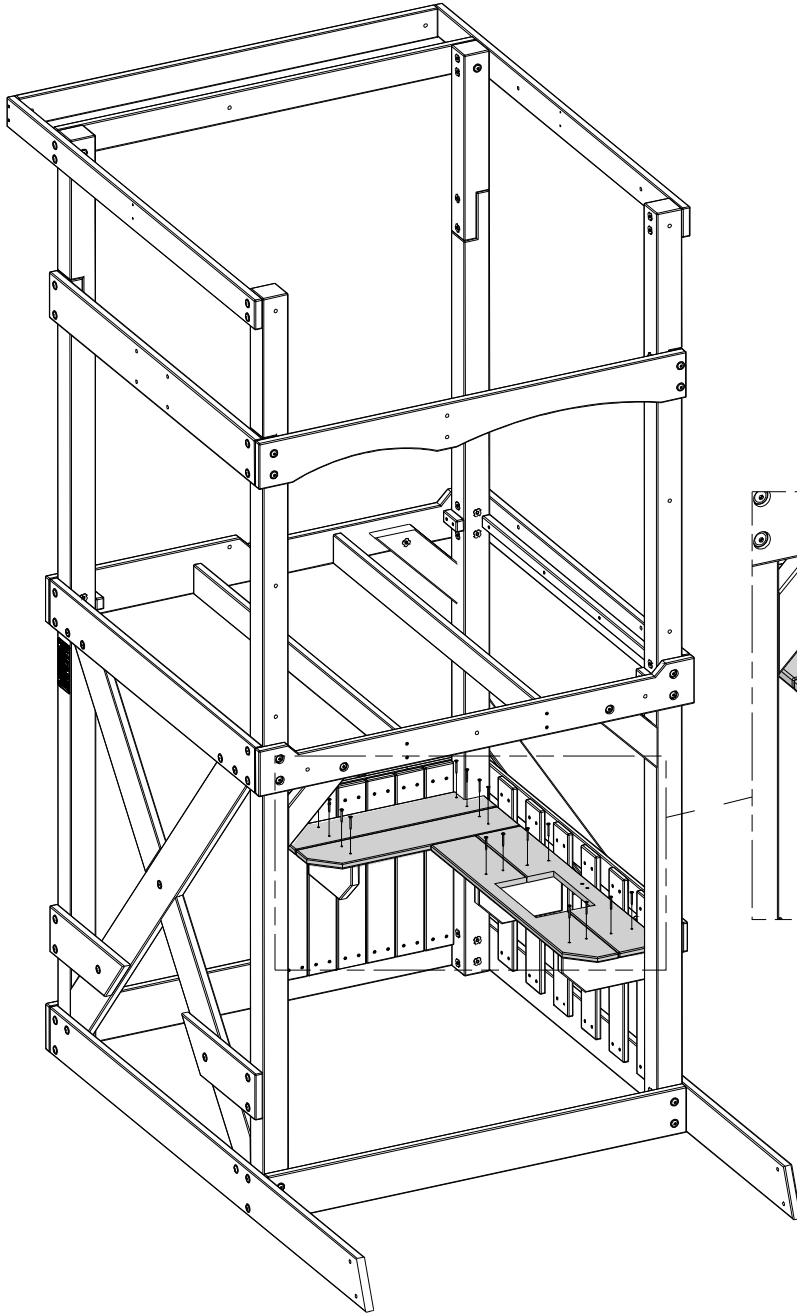

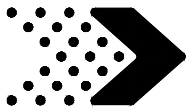

Phase 1

STEP 19



N2 | COUNTERTOP CLEAT - W4L12426
(x1) | 5/8"x2 3/8"x5 7/8" (16x60x150)



H100380 | SCREW PFH BLK
(x4) | 8x1 1/8

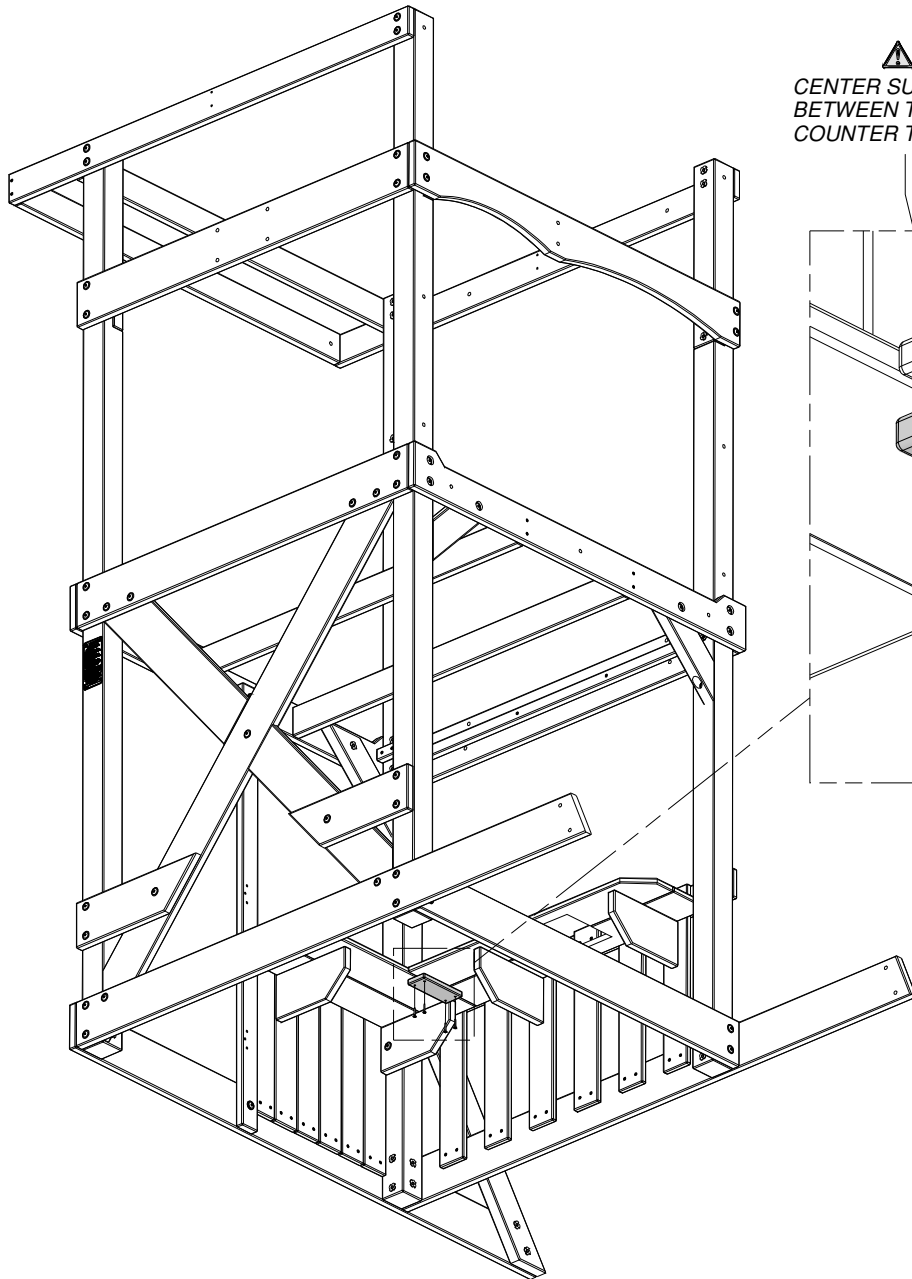

 CENTER SUPPORT
BETWEEN THE SHOWN
COUNTER TOP BOARDS.

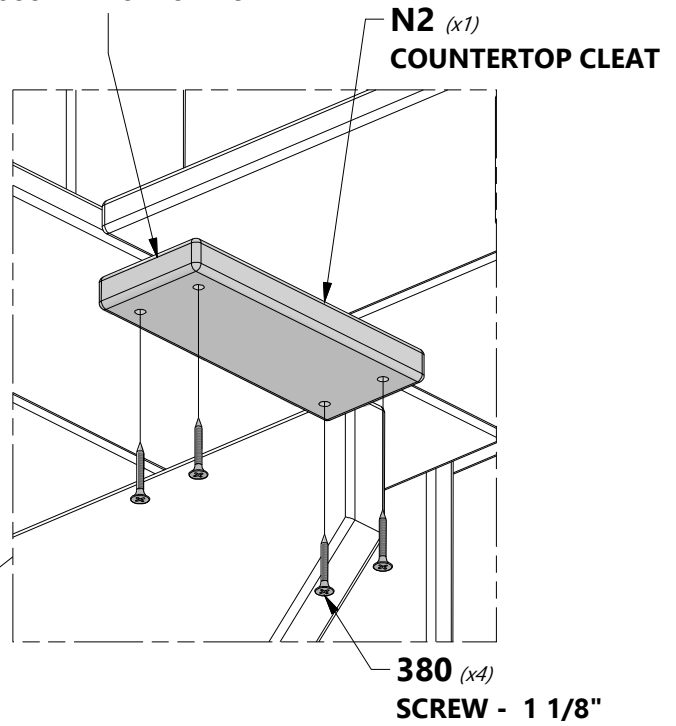

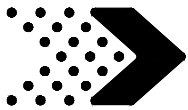

Phase 1

STEP 20

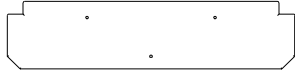

K7 | **COUNTER TOP - W4L12423**
(x1) | 5/8"x5 1/4"x22 1/2" (16x134x570)



H100200 | **SCREW PFH BLK**
(x3) | 8x1 1/2

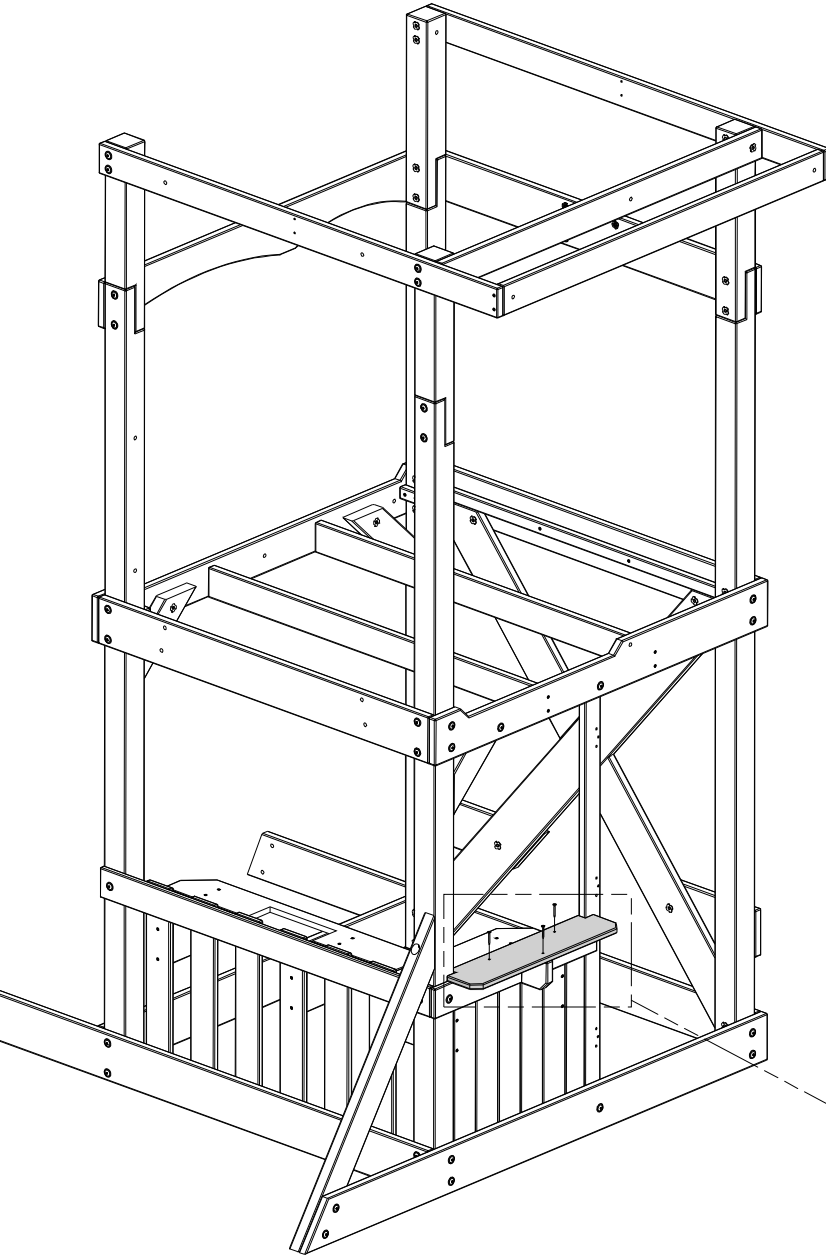

ASSEMBLY NOTE:
ALIGN THE PILOT HOLES TO
LOCATE K7 BOARD.

200 (x3)
SCREW - 1 1/2"

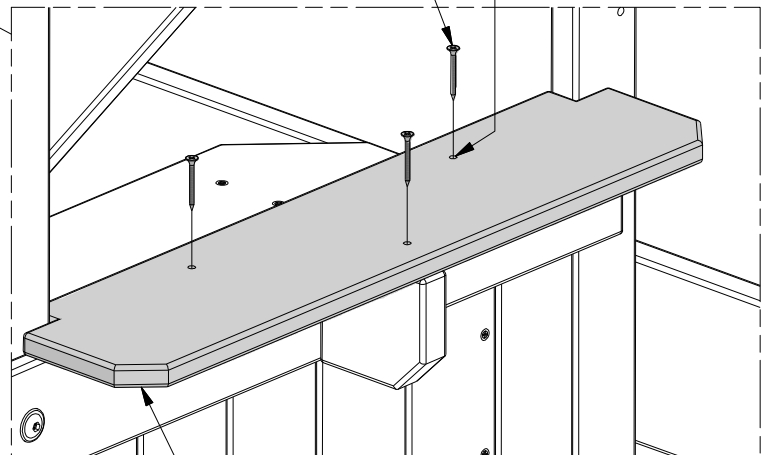

K7 (x1)
COUNTER TOP

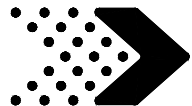

Phase 1

STEP 21

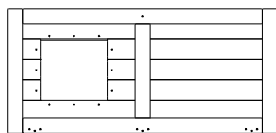

DP1 | DOOR PANEL - W2A02757
(x1) 1 1/8"x16 1/2"x43 7/8" (27x493x1072)

H100807 | SCREW POH BLK
(x9) 8/32x1

H100806 | SCREW POH BLK
(x9) 8/32x1 1/8

H100804 | T-NUT
(x18) 8/32

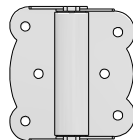

A4M00624 | HINGE (DOOR, SPRING LOADED)
(x2)

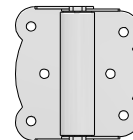

A4M00994 | HINGE (DOOR, NON-SPRING LOADED)
(x1)



ASSEMBLY NOTE:

START BY ATTACHING THE HINGES TO THE DOOR FIRST. MAKE SURE THE NON-SPRING LOADED HINGE IS MOUNTED USING THE CENTER PILOT HOLES ON THE DOOR.

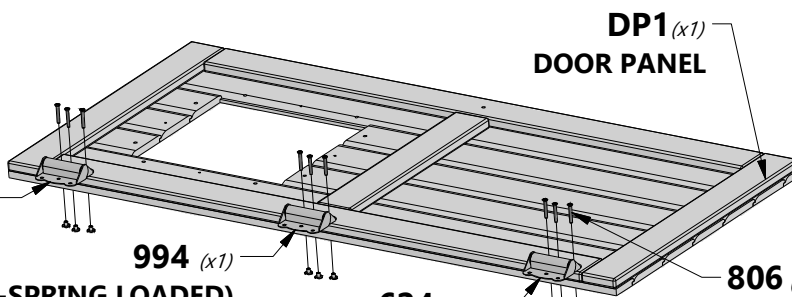

624 (x1) | HINGE (DOOR, SPRING LOADED)

994 (x1) | HINGE (DOOR, NON-SPRING LOADED)

624 (x1) | HINGE (DOOR, SPRING LOADED)

806 (x9) | SCREW - 1 1/8"

804 (x9) | T-NUT - 8/32"

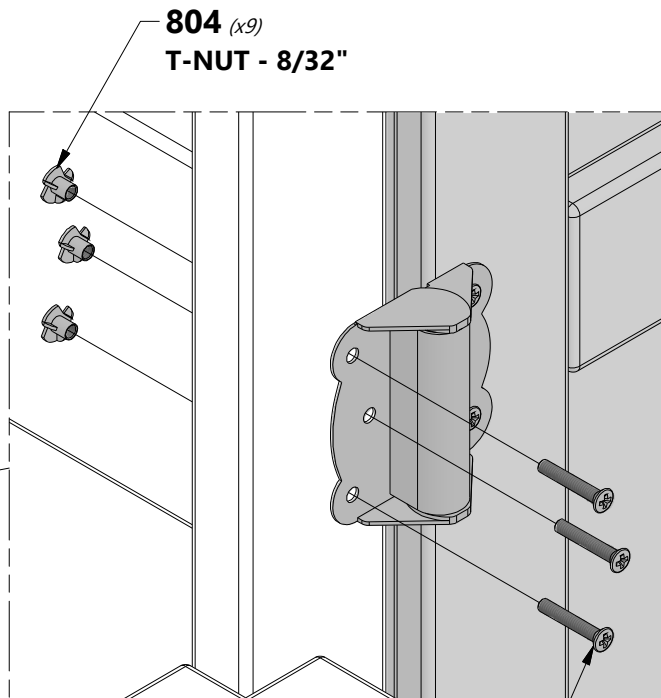
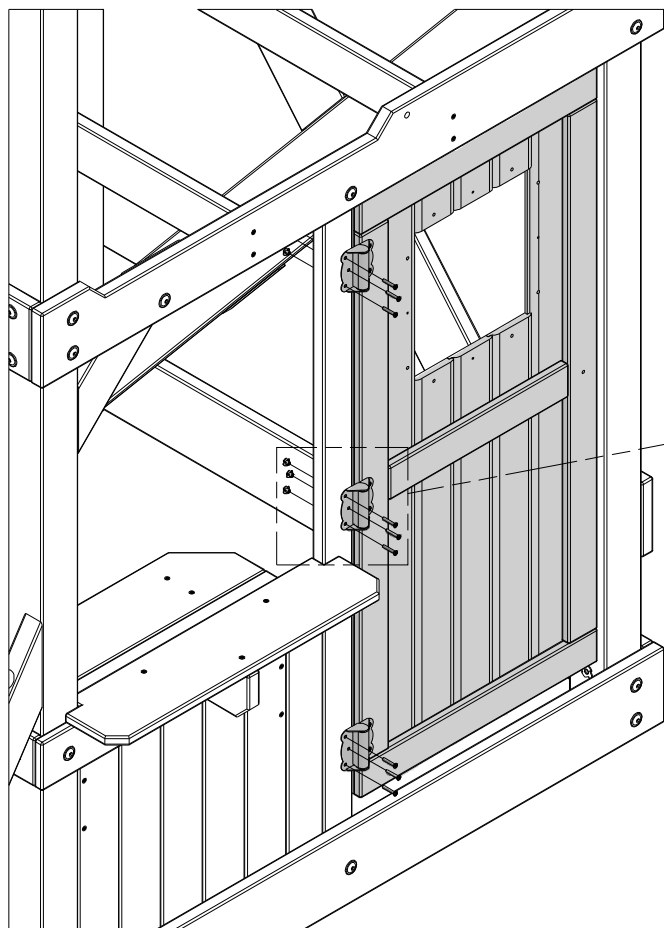
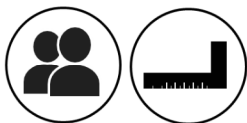

804 (x9) | T-NUT - 8/32"

807 (x9) | SCREW - 1"



ASSEMBLY TIP:

USE AN ADULT HELPER TO HOLD THE DOOR SQUARE WHILE YOU INSTALL THE DOOR.

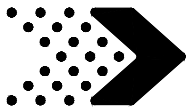

Phase 1

STEP 22



A6P00274 | **KNOB - DR.BRN**
(x1)



H100382 | **SCREW PFH BLK**
(x1) | 8x1 3/4

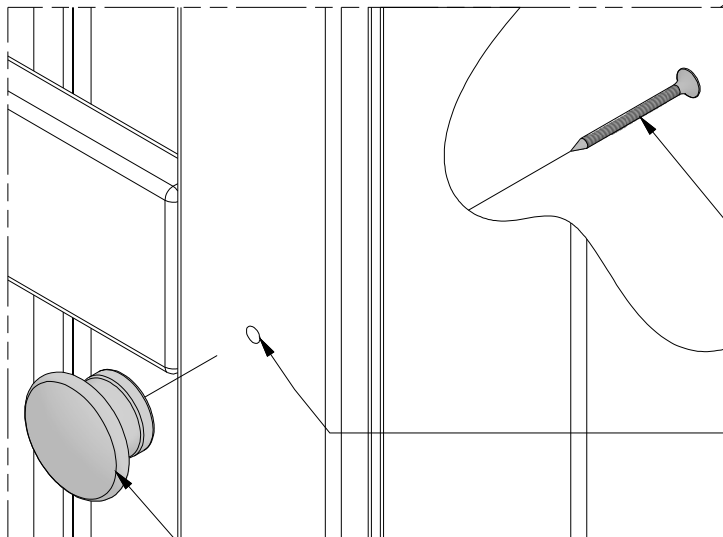
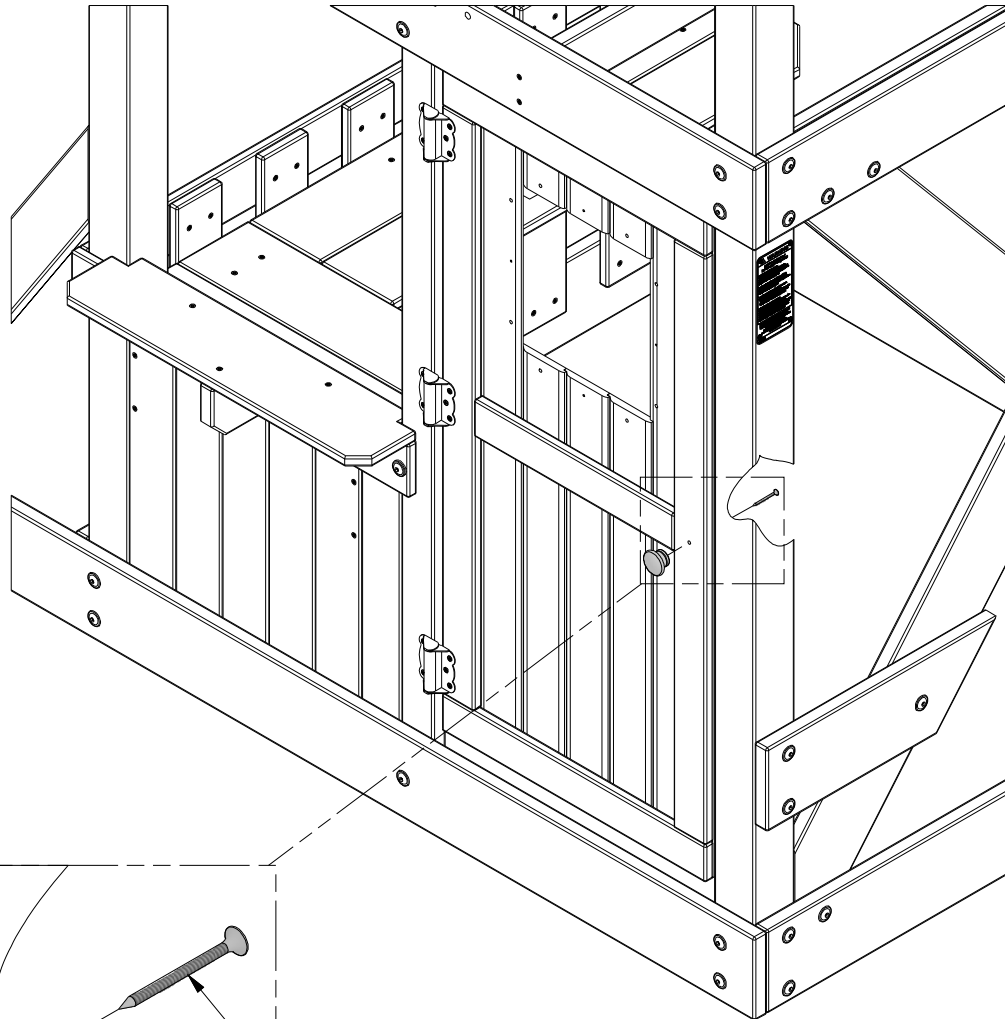

382 (x1)
SCREW - 1 3/4"

NOTE PILOT HOLE

274 (x1)
KNOB - DR.BRN

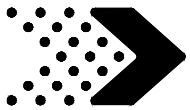

Phase 1

STEP 23

O3 | WINDOW TRIM - W4L12435
(x2) | 5/8"x1 3/8"x10 3/8" (16x34x265)

O4 | WINDOW TRIM - W4L12436
(x2) | 5/8"x1 3/8"x12" (16x34x306)

O6 | WINDOW TRIM - W4L12438
(x1) | 5/8"x1 3/8"x12" (16x34x306)

O5 | WINDOW TRIM - W4L12437
(x1) | 5/8"x1 3/8"x13 1/8" (16x34x333)

H100816 | SCREW PFH BLK
(x8) | 8x7/8

H100387 | SCREW PFH BLK
(x4) | 8x1-1/4

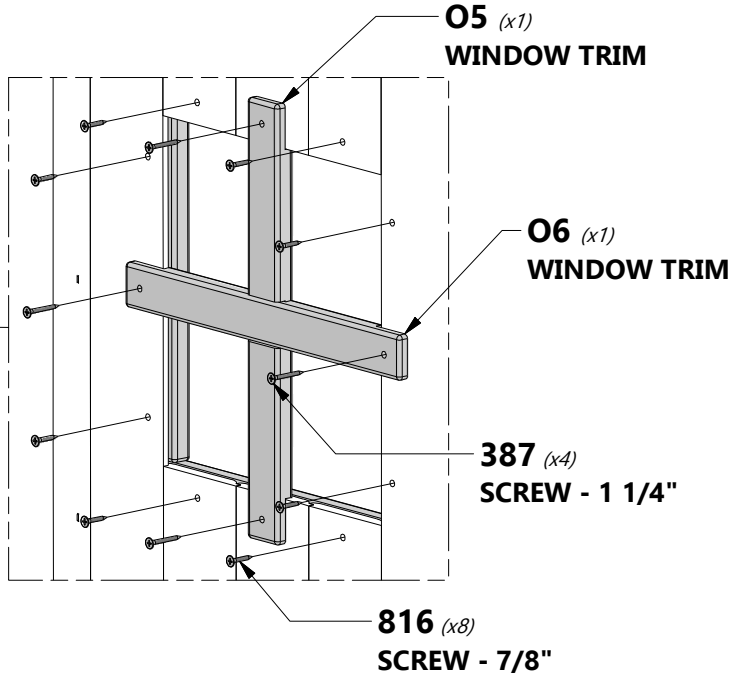
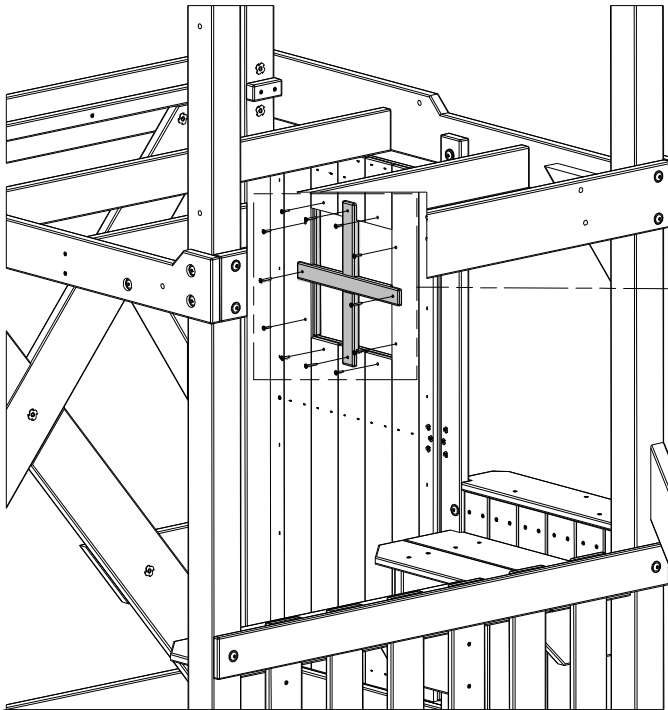

ASSEMBLY NOTE:

INSTALL OUTER WINDOW TRIM FIRST USING 7/8" SCREWS THEN INSTALL THE INSIDE TRIM USING 1-1/4" SCREWS.

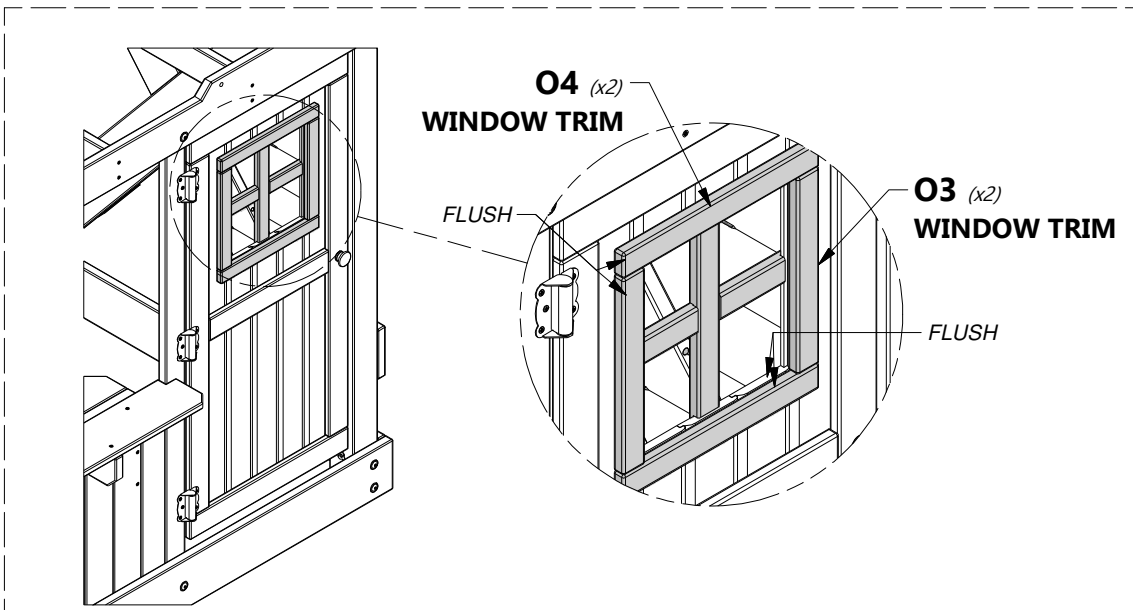

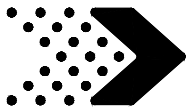

Phase 1

STEP 24

F3 | DOOR STOP - W4L12501
 (x2) | 1 3/8"x1 3/8"x3 7/8" (36x36x100)

H100201 | SCREW PFH BLK
 (x4) | 8x2-1/2

 **ASSEMBLY NOTE:**
 MOUNT THE DOOR STOPS
 USING THE DIMENSIONS AS
 SHOWN.

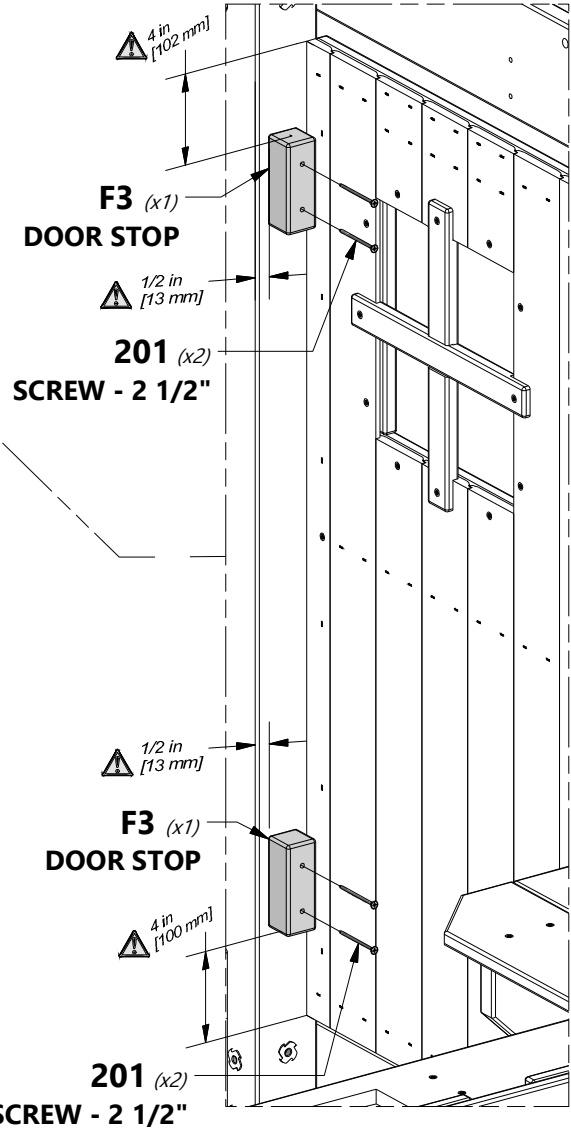
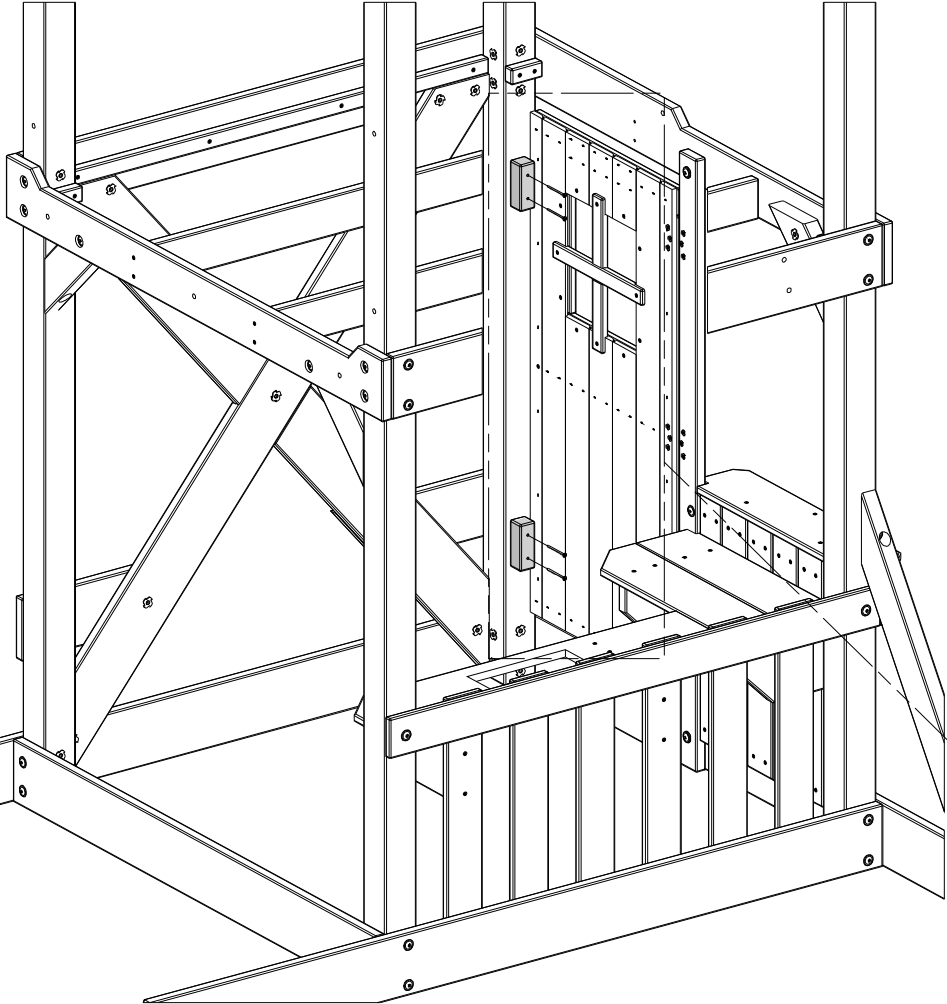

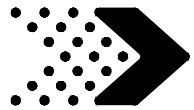

Phase 1

STEP 25

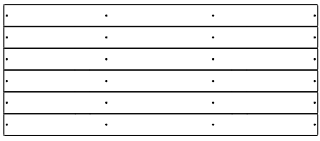

FP1 | FLOOR PANEL - W2A02746
(x1) 1 1/4"x20 7/16"x49 1/16" (32x519x1247)

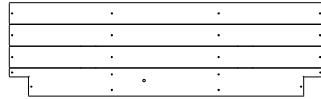

FP2 | FLOOR PANEL - W2A02747
(x1) 1 1/4"x14 5/8"x49 1/16" (32x372x1247)

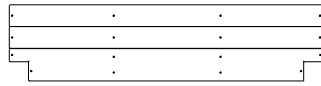

FP3 | FLOOR PANEL - W2A02749
(x1) 1 1/4"x11 7/8"x49 1/16" (32x302x1247)



H100200 | SCREW PFH BLK
(x60) 8x1 1/2



ASSEMBLY TIP:
PLACE FLOOR PANELS AS SHOWN FIRST. THEN USING THE PRE-DRILLED HOLES MOUNT THEM WITH THE PROVIDED SCREWS.

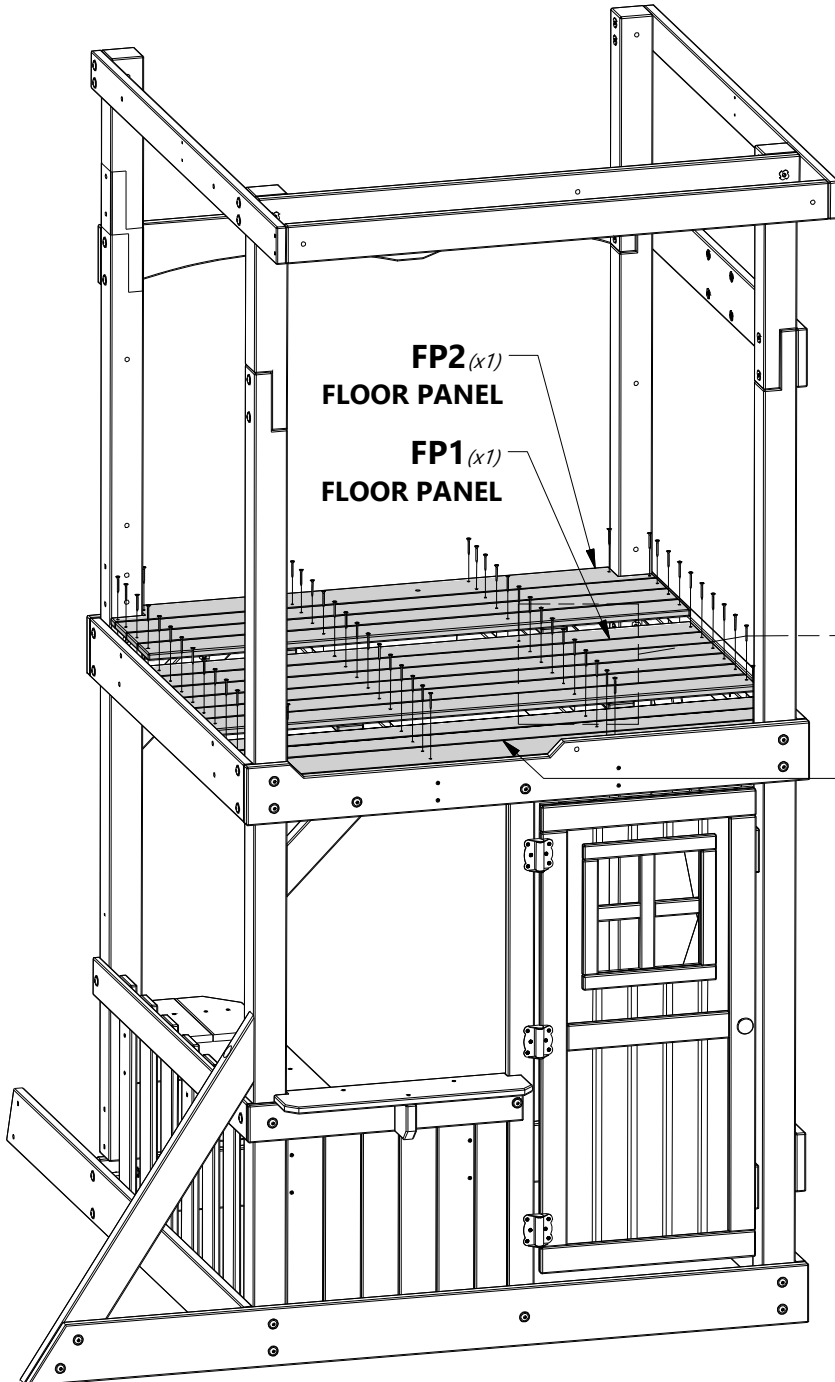

FP2 (x1)
FLOOR PANEL

FP1 (x1)
FLOOR PANEL

FP3 (x1)
FLOOR PANEL

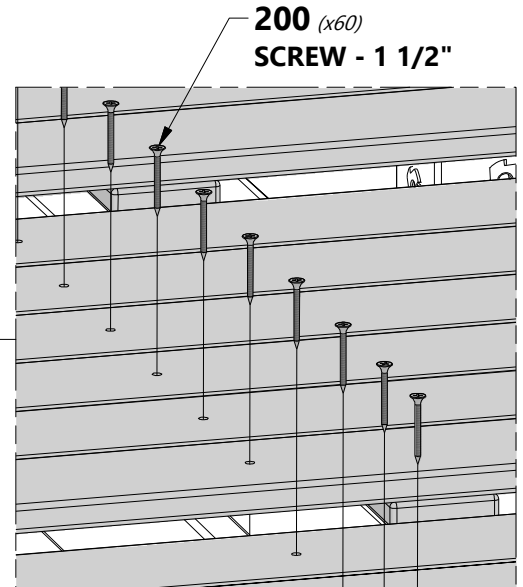

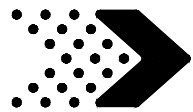

Phase 1

STEP 26



F1 | WALL UPRIGHT - W4L12398
(x2) | 1 3/8"x2 3/8"x60 3/8" (36x60x1533)



H100205 | BOLT WH BLK
(x4) | 5/16x2-1/4



H100198 | WASHER LOCK EXT BLK
(x4) | 8x19



H100379 | T-NUT BLK
(x4) | 5/16

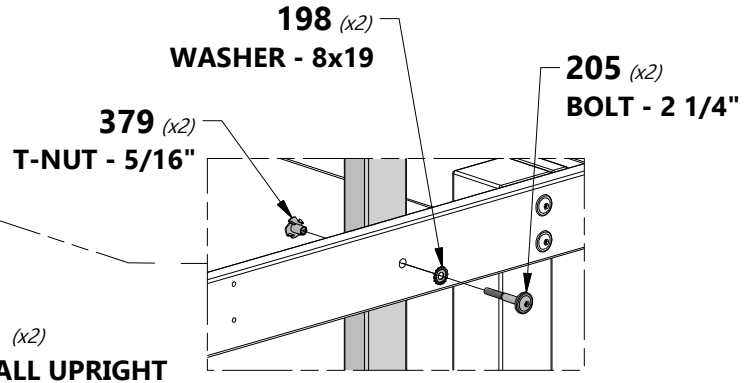
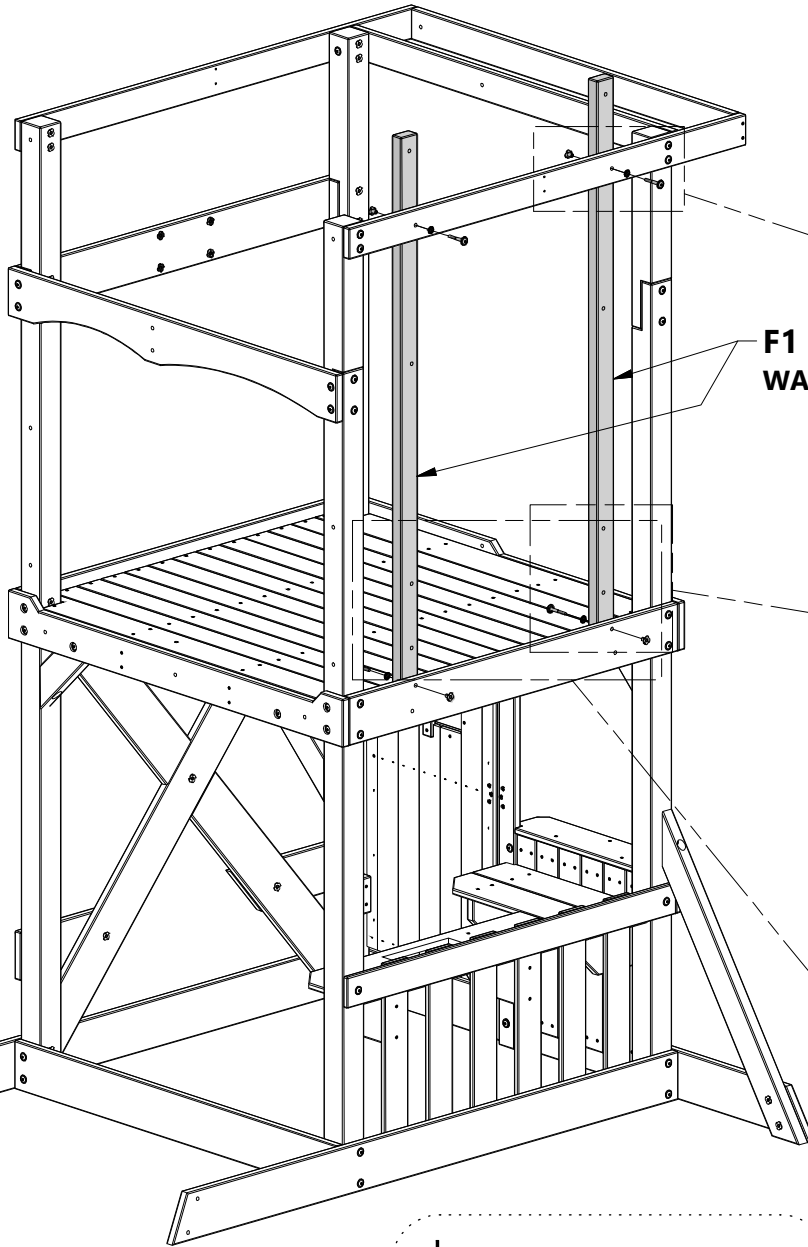

198 (x2)
WASHER - 8x19
379 (x2)
T-NUT - 5/16"
205 (x2)
BOLT - 2 1/4"

F1 (x2)
WALL UPRIGHT

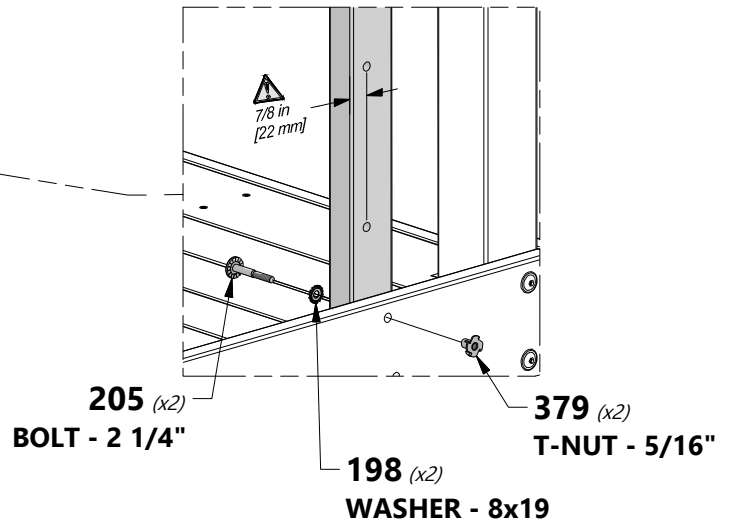

205 (x2)
BOLT - 2 1/4"
379 (x2)
T-NUT - 5/16"
198 (x2)
WASHER - 8x19

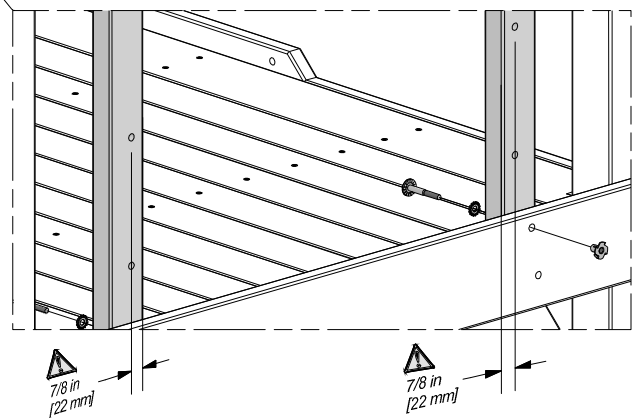

7/8 in [22 mm]

ASSEMBLY NOTE:
NOTE THE DIAGRAM TO THE RIGHT. NOTE HOW THE F1 BOARDS MIRROR EACH OTHER WITH THE SHOWN HOLES BEING CLOSER TO THE INSIDE OPENING.

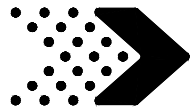

Phase 1

STEP 27



H5 | DECK SUPPORT - W4L12408
(x1) | 1"x3 3/8"x30 3/8" (24x86x772)



A100340 | L BRACKET 2.5x38x50x55
(x2)



H100457 | BOLT WH BLK
(x2) | 5/16x2

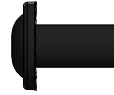

H100192 | NUT BARREL WH BLK
(x2) | 5/16x7/8



H100199 | WASHER LOCK EXT BLK
(x2) | 12x19



ASSEMBLY NOTE:
THE BRACKET ORIENTATION IS CRITICAL. PLEASE ORIENTATE WITH DIMENSIONS BELOW AS SHOWN.

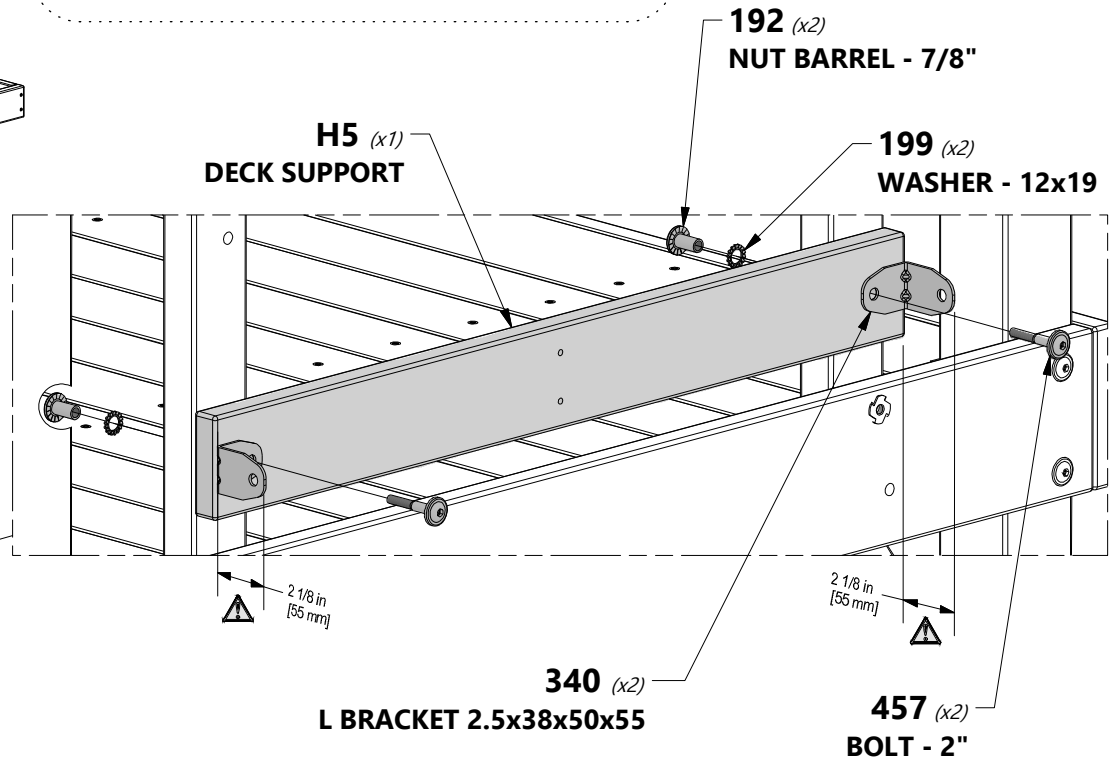
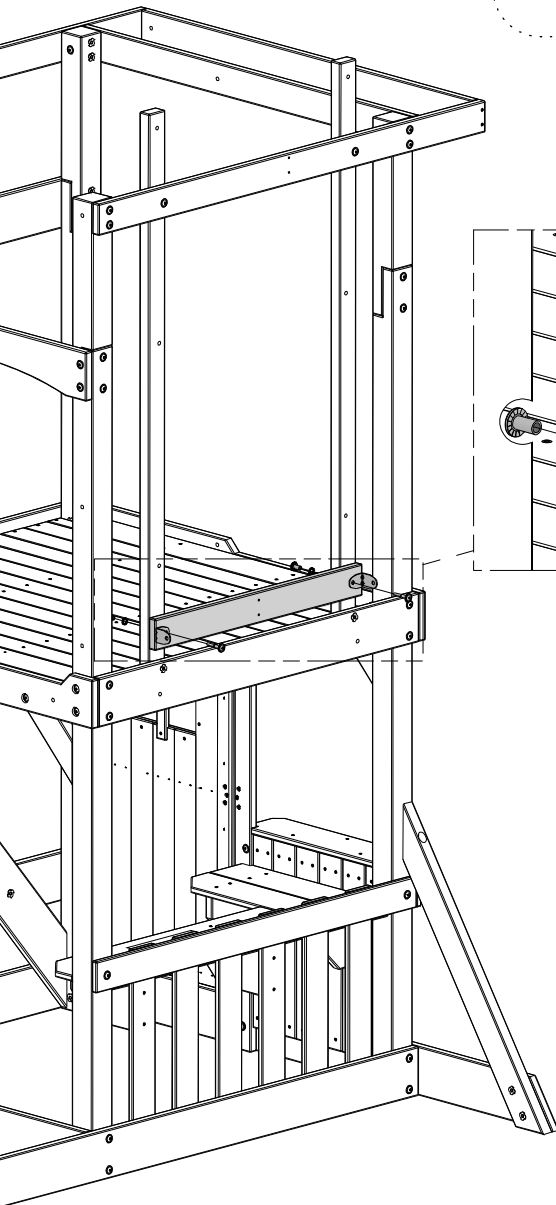
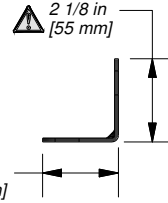

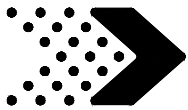

Phase 1

STEP 28

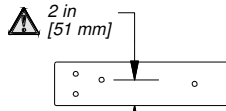

H2 | **DECK SUPPORT - W4L12403**
(x2) | 1"x3 3/8"x13 5/8" (24x86x345)

H100396 | **BOLT WH BLK**
(x2) | 5/16x1/2

H100192 | **NUT BARREL WH BLK**
(x2) | 5/16x7/8

H100199 | **WASHER LOCK EXT BLK**
(x2) | 12x19

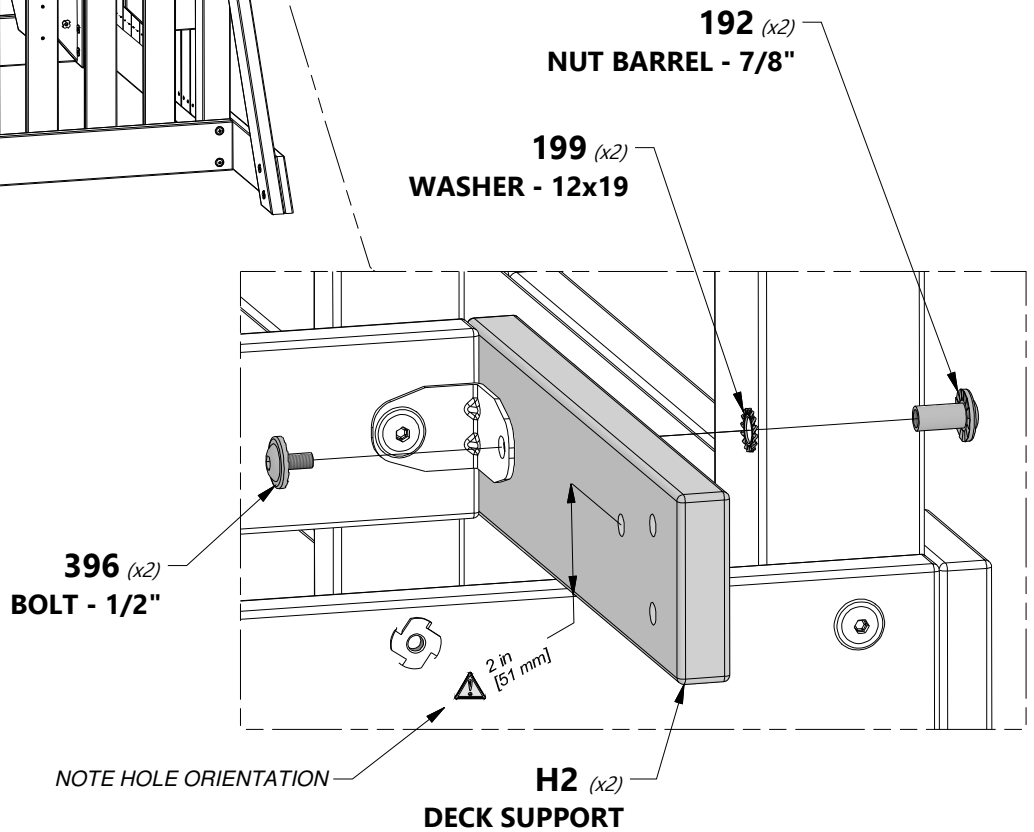
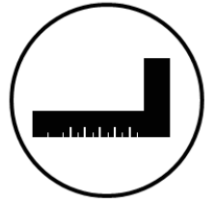
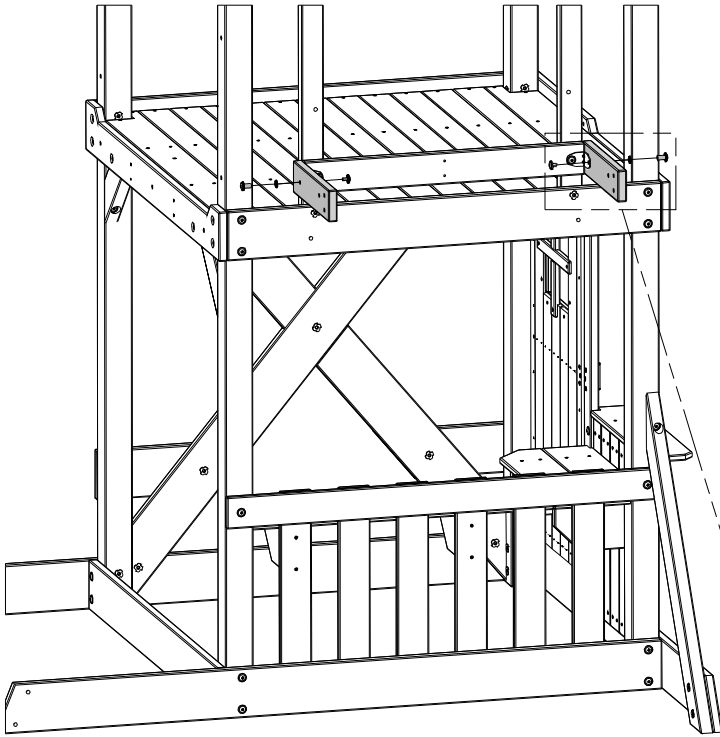

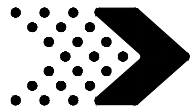

Phase 1

STEP 29

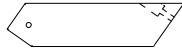

E2 | **BRACE - W4L12418**
(x2) | 1 3/8"x3 3/8"x13 7/8" (36x86x351)



H100205 | **BOLT WH BLK**
(x2) | 5/16x2-1/4



H100198 | **WASHER LOCK EXT BLK**
(x4) | 8x19



H100457 | **BOLT WH BLK**
(x2) | 5/16x2



H100379 | **T-NUT BLK**
(x2) | 5/16

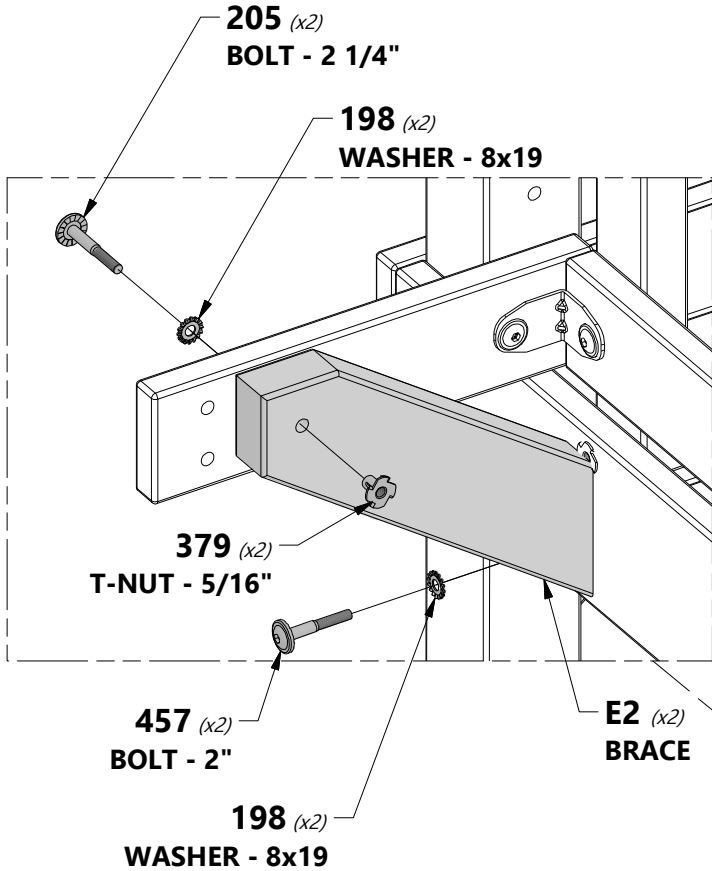

ASSEMBLY NOTE:

AT THIS TIME YOU WILL MOUNT THE BRACES USING THE T-NUTS THAT WERE PREVIOUSLY INSTALLED.

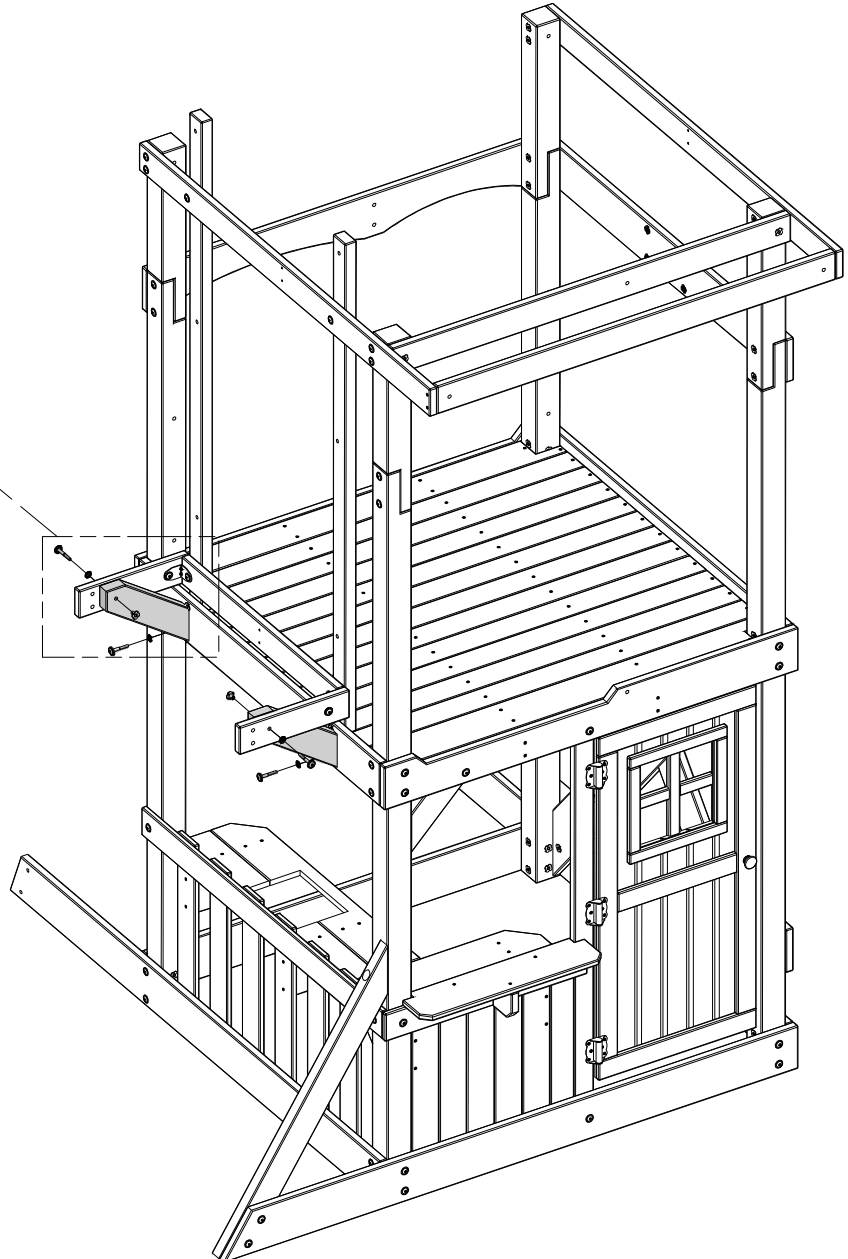
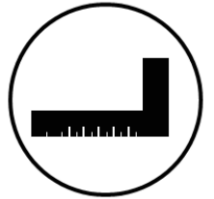

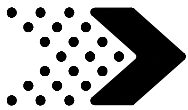

Phase 1

STEP 30

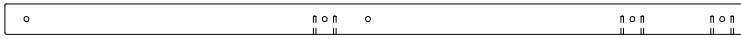

F2 | WALL UPRIGHT - W4L12405
(x2) | 1 3/8"x2 3/8"x57 3/4" (36x60x1467)



H100197 | LAG SCREW WH BLK
(x4) | 5/16x2 1/2



H100198 | WASHER LOCK EXT BLK
(x4) | 8x19



H100379 | T-NUT BLK
(x2) | 5/16

PRE-INSTALL T-NUTS

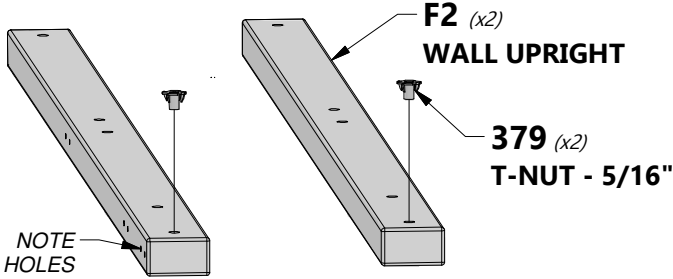

F2 (x2)
WALL UPRIGHT

379 (x2)
T-NUT - 5/16"

NOTE
PILOT HOLES
USED BELOW



ASSEMBLY NOTE:

START BY INSTALLING THE T-NUTS AS SHOWN. NOTE THE BOARDS SHOULD MIRROR EACH OTHER WITH THE PILOT HOLES FACING OUTWARD AS SHOWN.

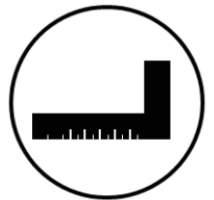

F2 (x2)
SHOWN ABOVE

NOTE
PILOT HOLES

NOTE T-NUT
IS HIDDEN
BEHIND F2

198 (x4)
WASHER - 8x19

197 (x4)
LAG SCREW - 2 1/2"

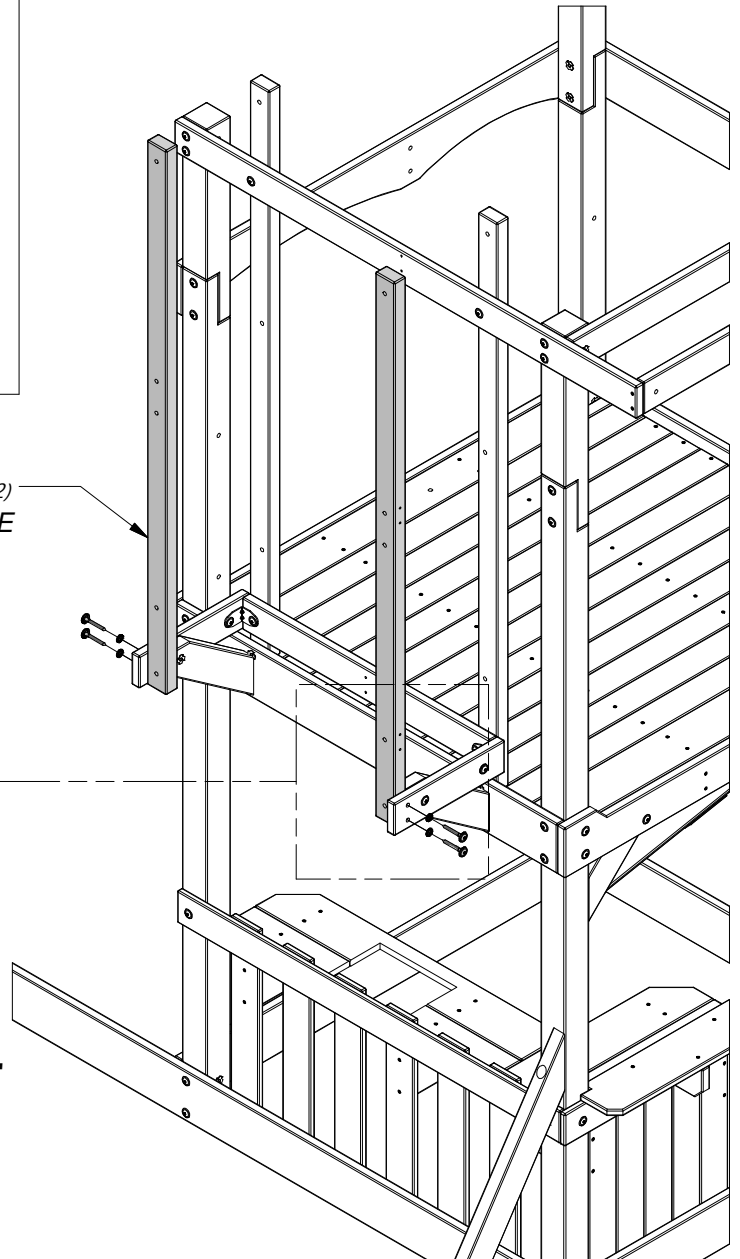

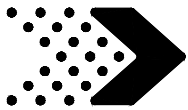

Phase 1

STEP 31

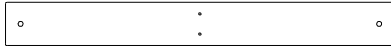

H4 | **DECK SUPPORT - W4L12414**
(x1) | 1"x3 3/8"x30 3/8" (24x86x772)



H100205 | **BOLT WH BLK**
(x2) | 5/16x2-1/4



H100198 | **WASHER LOCK EXT BLK**
(x2) | 8x19



ASSEMBLY TIP:
MOUNT H4 USING THE
T-NUTS INSTALLED ON THE
PREVIOUS STEP.

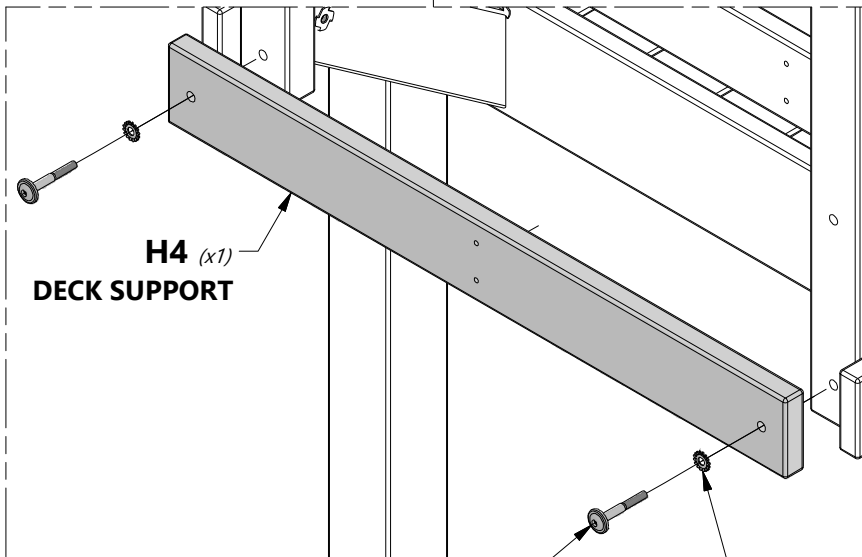
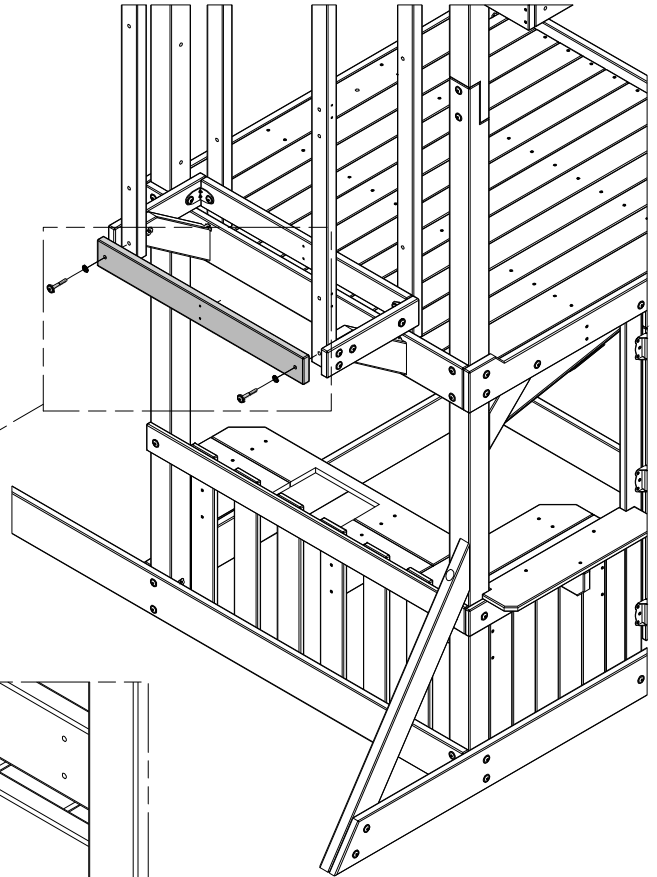

H4 (x1)
DECK SUPPORT

205 (x2)
BOLT - 2 1/4"

198 (x2)
WASHER - 8x19



Phase 1

STEP 32



H6 (x2) | **TOP RAIL BOARD - W4L12406**
1"x3 3/8"x13 5/8" (24x86x345)



A100340 (x2) | **L BRACKET 2.5x38x50x55**



H100197 (x4) | **LAG SCREW WH BLK**
5/16x2 1/2



H100396 (x2) | **BOLT WH BLK**
5/16x1/2



H100468 (x2) | **BOLT WH BLK**
5/16x1

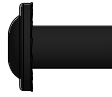

H100192 (x4) | **NUT BARREL WH BLK**
5/16x7/8



H100198 (x4) | **WASHER LOCK EXT BLK**
8x19



H100199 (x4) | **WASHER LOCK EXT BLK**
12x19

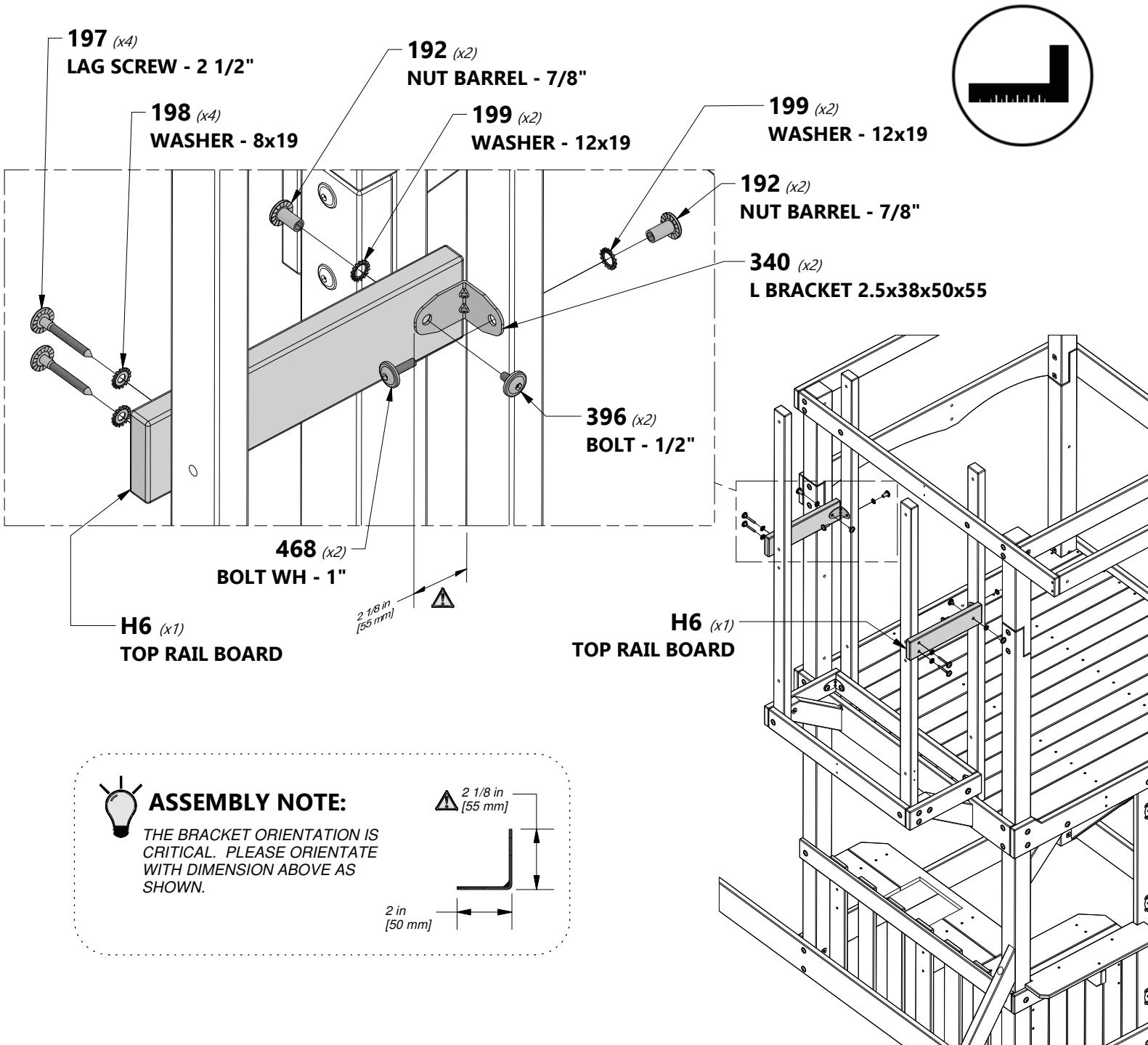

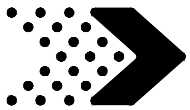

Phase 1

STEP 33



H7 | **TOP RAIL BOARD - W4L12404**
(x1) | 1"x3 3/8"x30 3/8" (24x86x772)



H100205 | **BOLT WH BLK**
(x2) | 5/16x2-1/4



H100198 | **WASHER LOCK EXT BLK**
(x2) | 8x19



H100379 | **T-NUT BLK**
(x2) | 5/16

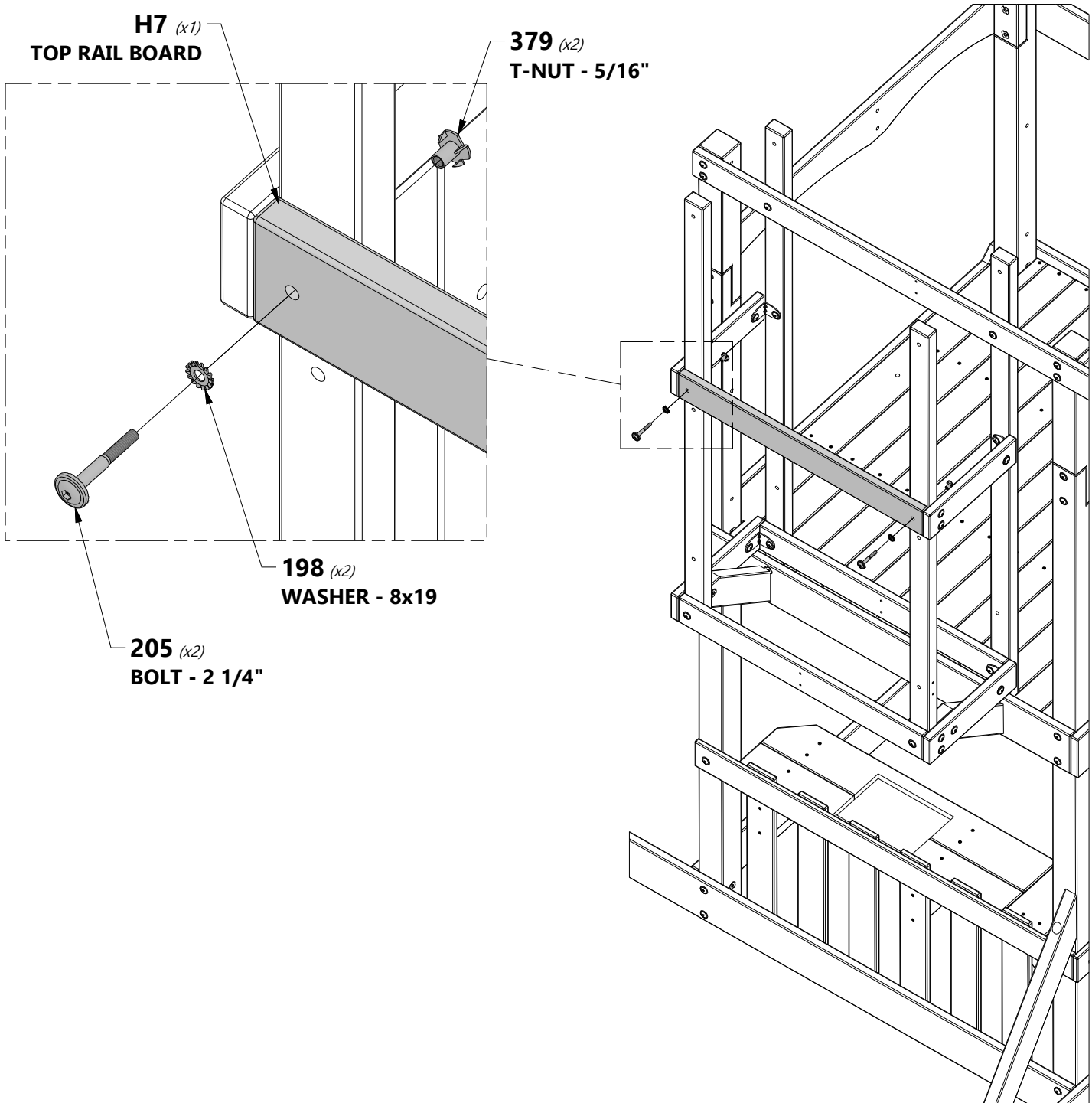

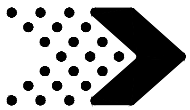

H3 | **DECK SUPPORT - W4L12410**
(x1) | 1"x3 3/8"x11 3/4" (24x86x297)



H100201 | **SCREW PFH BLK**
(x4) | 8x2-1/2

 **ASSEMBLY NOTE:**
USE THE PILOT HOLES IN H3
TO ALIGN AND MOUNT IT.

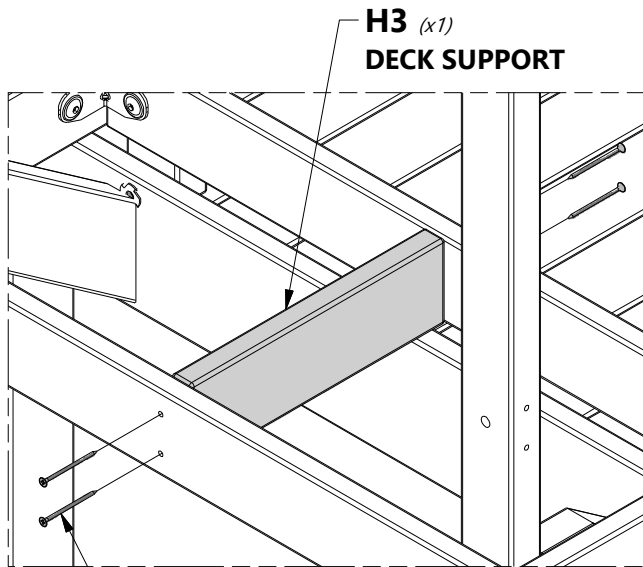

H3 (x1)
DECK SUPPORT

201 (x4)
SCREW - 2 1/2"

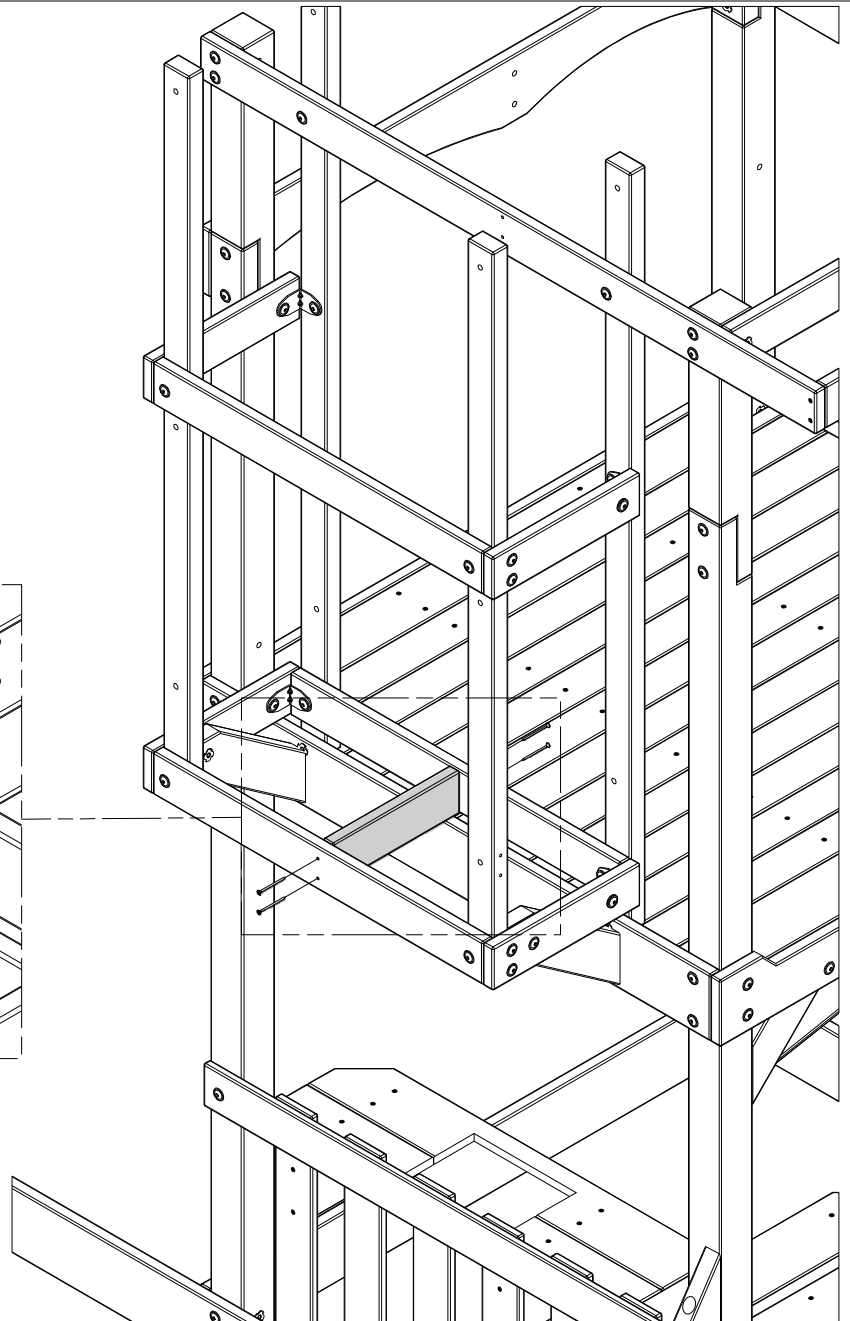

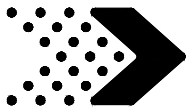

Phase 1

STEP 35

M1 | DECK BOARD - W4L12409
(x1) | 5/8"x3 3/8"x32 1/4" (16x86x820)

M2 | DECK BOARD - W4L12411
(x2) | 5/8"x3 3/8"x32 1/4" (16x86x820)

M3 | DECK BOARD - W4L12412
(x1) | 5/8"x3 3/8"x32 1/4" (16x86x820)

H100200 | SCREW PFH BLK
(x22) | 8x1 1/2



ASSEMBLY NOTE:

USING THE PRE-DRILLED HOLES MOUNT THE FLOOR BOARDS WITH THE PROVIDED SCREWS. MAKE SURE ALL SCREWS LAND IN THE JOISTS BELOW.

200 (x22)
SCREW - 1 1/2"

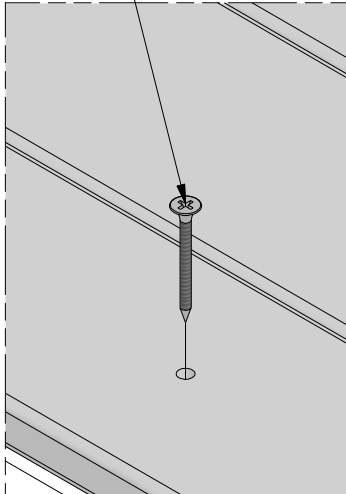

M3 (x1)
DECK BOARD

M2 (x2)
DECK BOARD

M1 (x1)
DECK BOARD

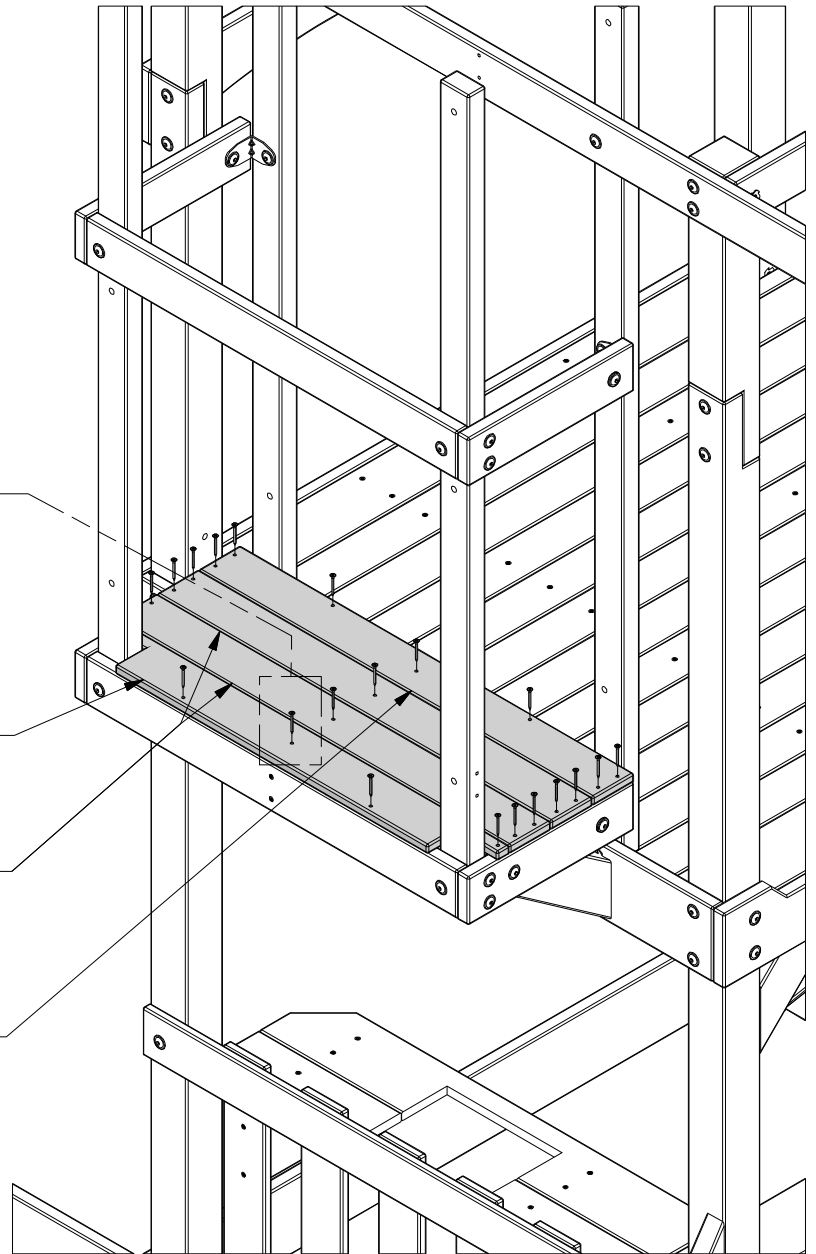

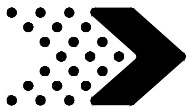

Phase 1

STEP 36



A100340 (x2) | L BRACKET 2.5x38x50x55

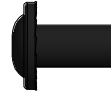

H100192 (x2) | NUT BARREL WH BLK
5/16x7/8



H100468 (x2) | BOLT WH BLK
5/16x1



H100199 (x2) | WASHER LOCK EXT BLK
12x19



ASSEMBLY NOTE:

THE BRACKET ORIENTATION IS CRITICAL. PLEASE ORIENTATE WITH DIMENSION BELOW AS SHOWN.

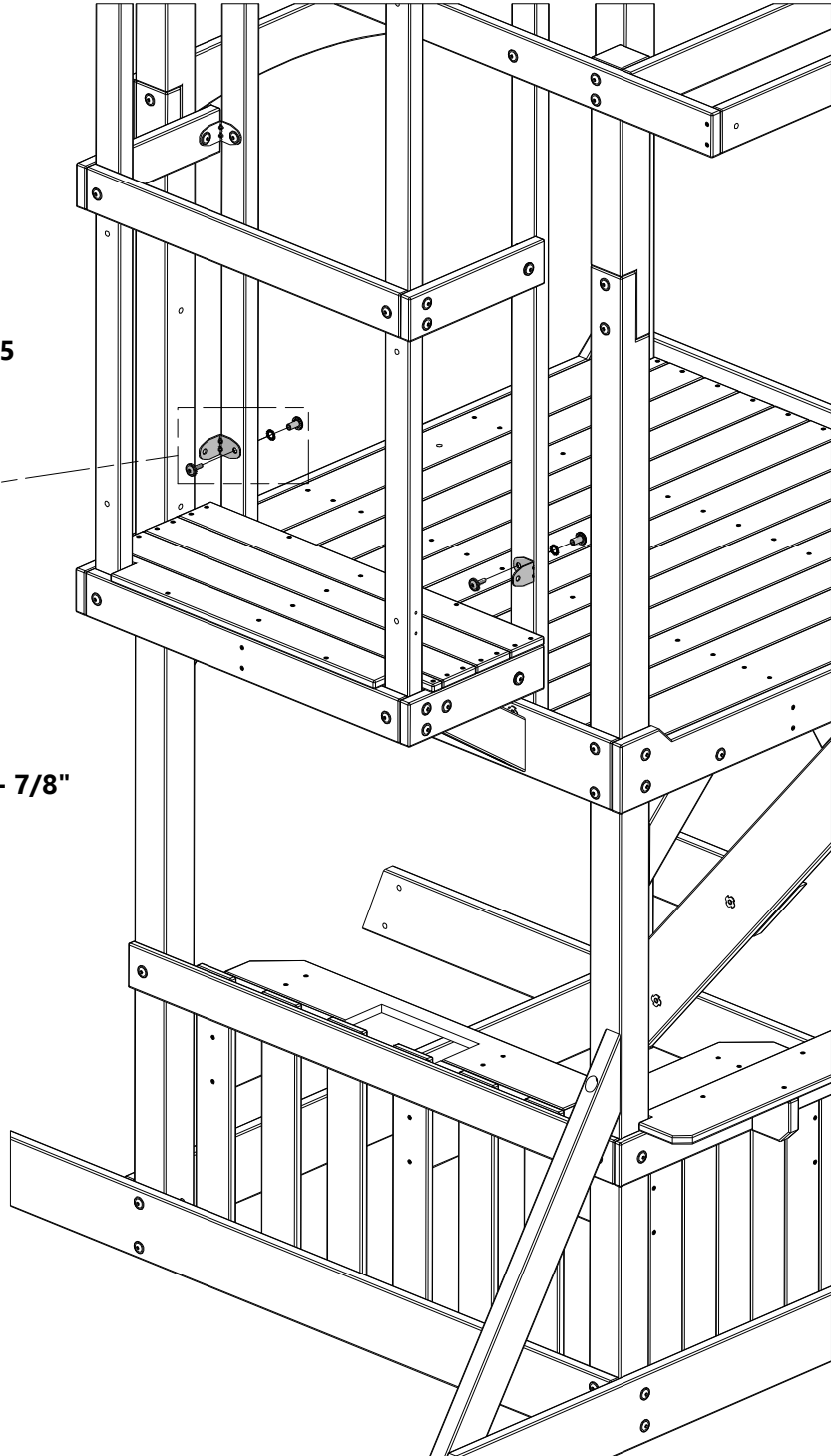
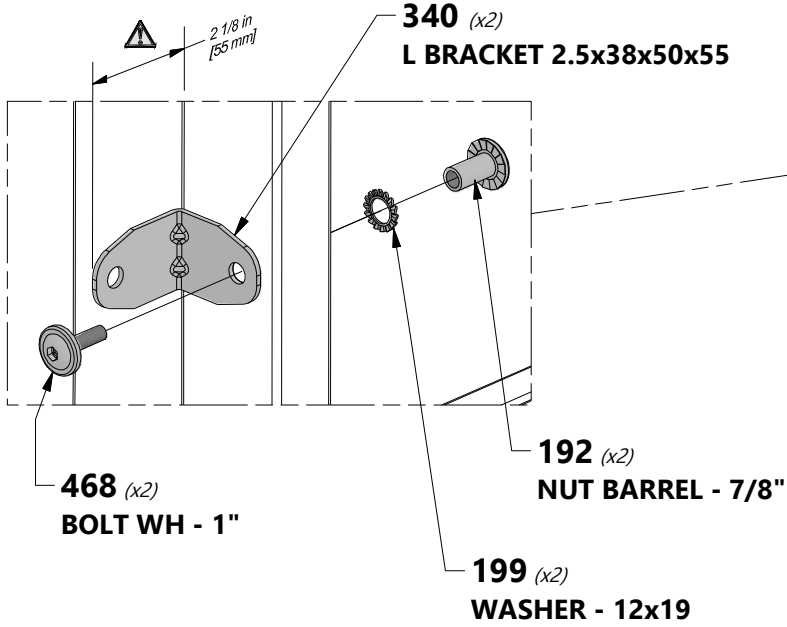
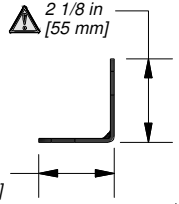

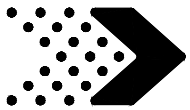

Phase 1

STEP 37



H6 | TOP RAIL BOARD - W4L12406
(x2) | 1"x3 3/8"x13 5/8" (24x86x345)



H100197 | LAG SCREW WH BLK
(x4) | 5/16x2 1/2



H100192 | NUT BARREL WH BLK
(x2) | 5/16x7/8



H100396 | BOLT WH BLK
(x2) | 5/16x1/2



H100198 | WASHER LOCK EXT BLK
(x4) | 8x19



H100199 | WASHER LOCK EXT BLK
(x2) | 12x19

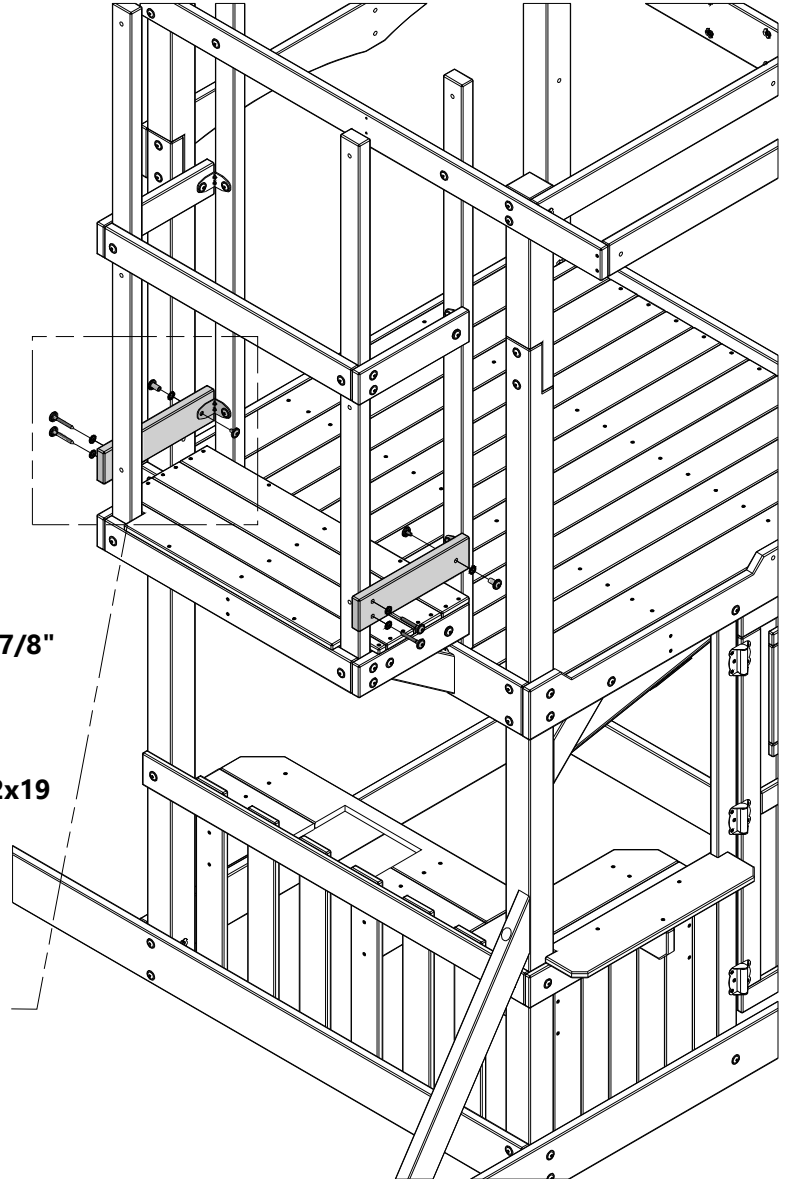
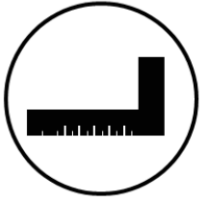

198 (x4)
WASHER - 8x19

192 (x2)
NUT BARREL - 7/8"

197 (x4)
LAG SCREW - 2 1/2"

199 (x2)
WASHER - 12x19

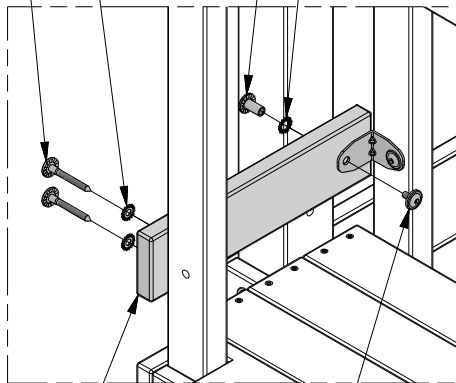

H6 (x2)
TOP RAIL BOARD

396 (x2)
BOLT - 1/2"

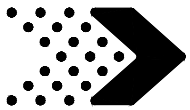

Phase 1

STEP 38



J4 | **SLIDE ATTACHMENT BOARD - W4L12407**
(x2) | 1"x2 3/8"x27 5/8" (24x60x703)



H100205 | **BOLT WH BLK**
(x4) | 5/16x2-1/4



H100198 | **WASHER LOCK EXT BLK**
(x4) | 8x19



H100379 | **T-NUT BLK**
(x4) | 5/16

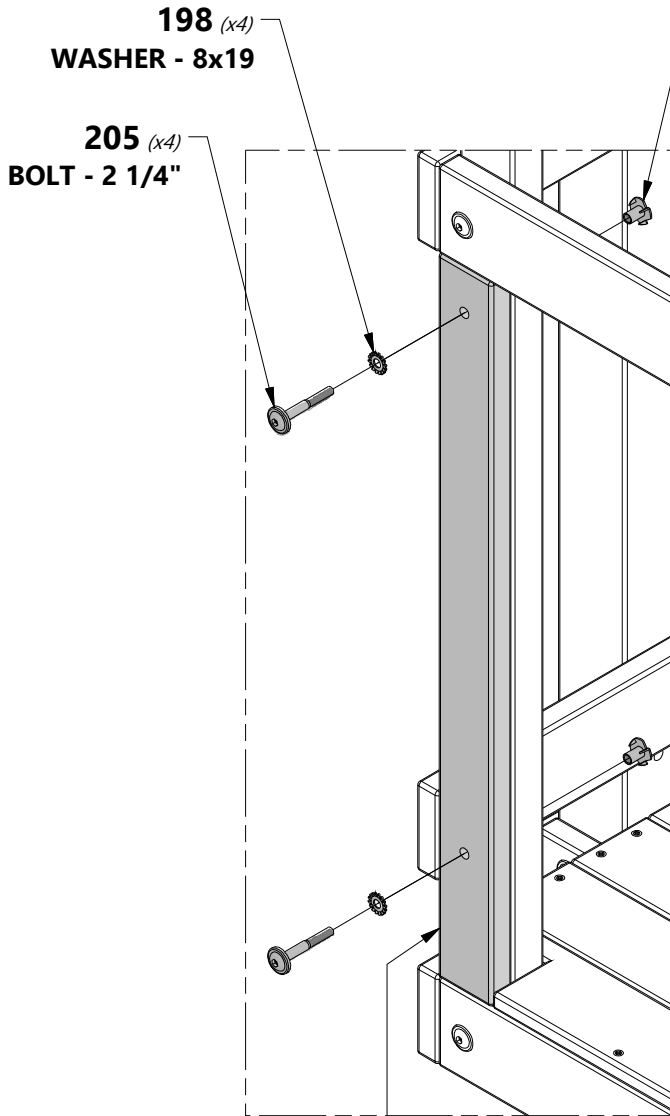

379 (x4)
T-NUT - 5/16"

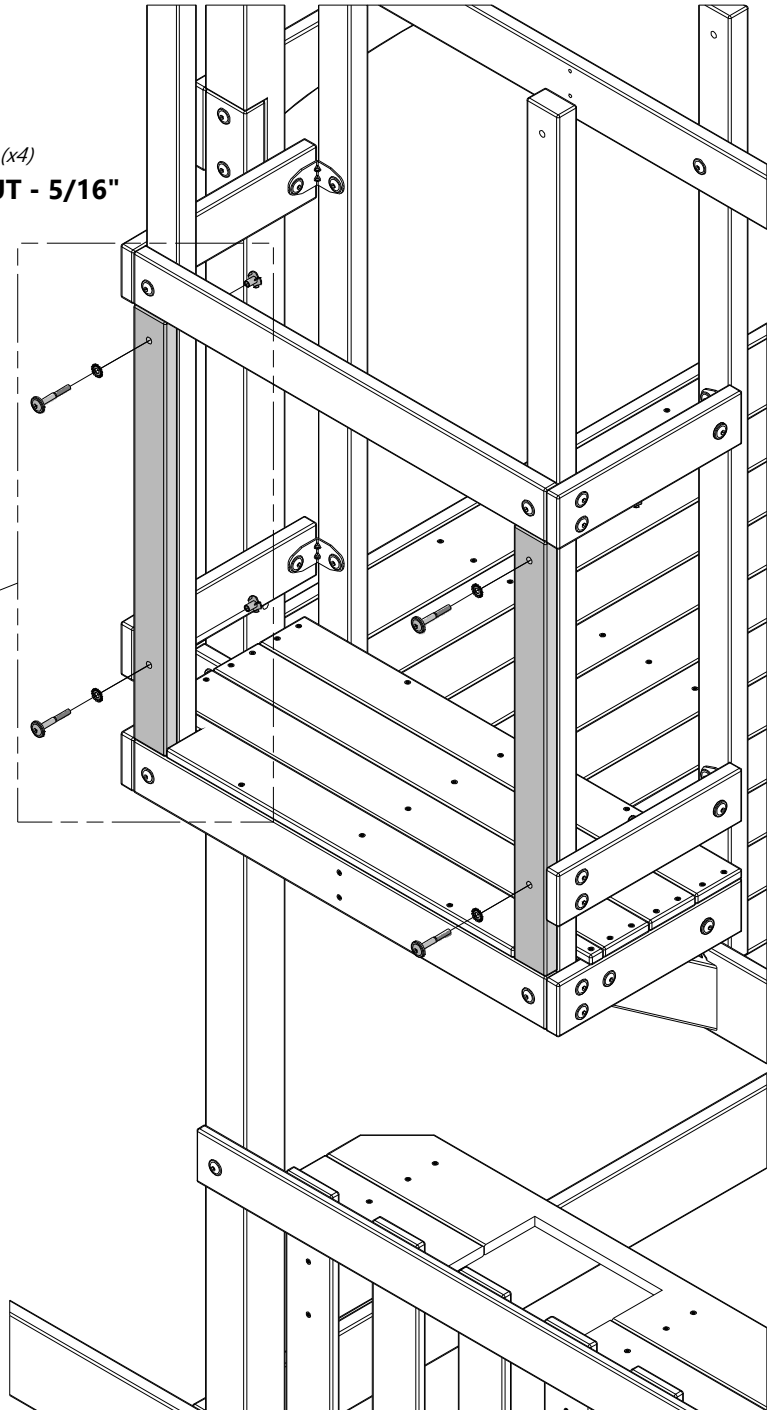

J4 (x2)
SLIDE ATTACHMENT BOARD

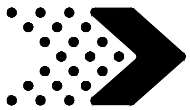

Phase 1

STEP 39

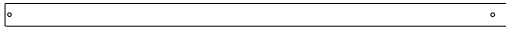

J2 | WALL UPRIGHT - W4L12302
(x1) | 1"x2 3/8"x52 1/2" (24x60x1334)



H100378 | BOLT WH BLK
(x1) | 5/16x1 3/4



H100407 | BOLT WH BLK
(x1) | 5/16x1 1/2

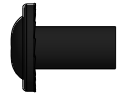

H100192 | NUT BARREL WH BLK
(x1) | 5/16x7/8



H100198 | WASHER LOCK EXT BLK
(x2) | 8x19



H100379 | T-NUT BLK
(x1) | 5/16



H100199 | WASHER LOCK EXT BLK
(x1) | 12x19

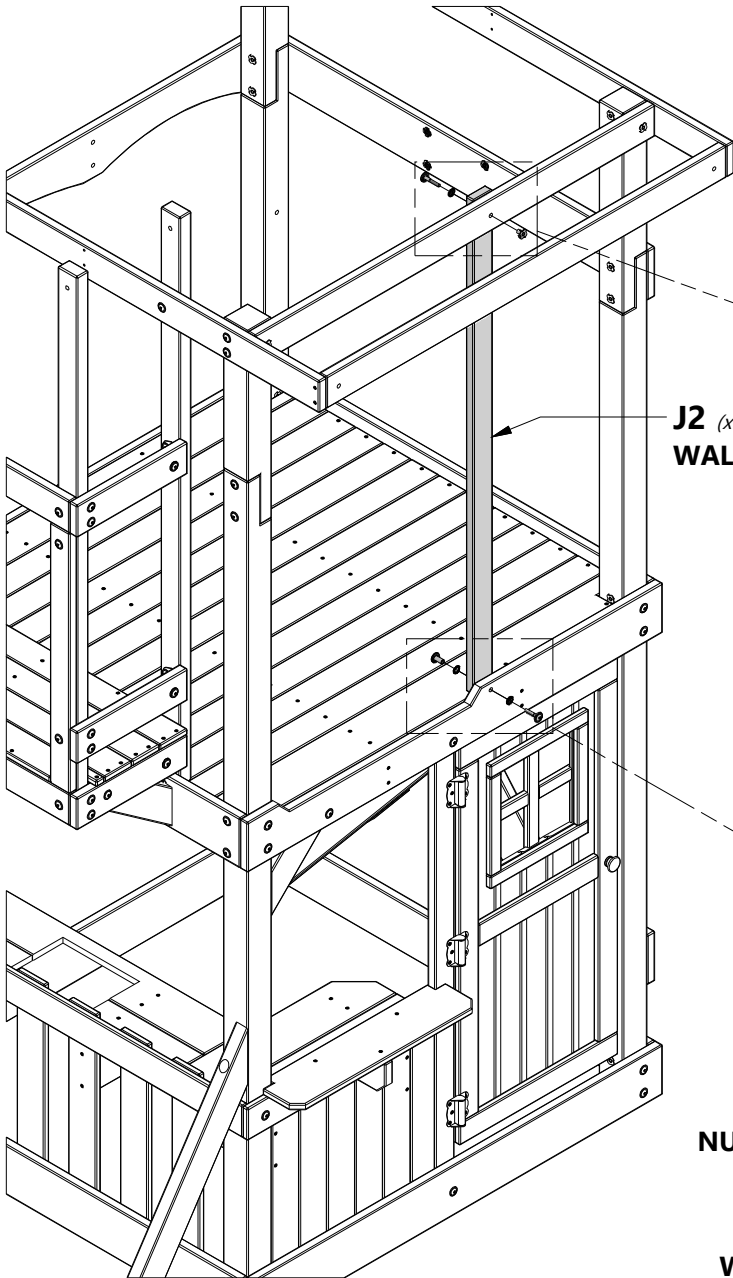

J2 (x1)
WALL UPRIGHT

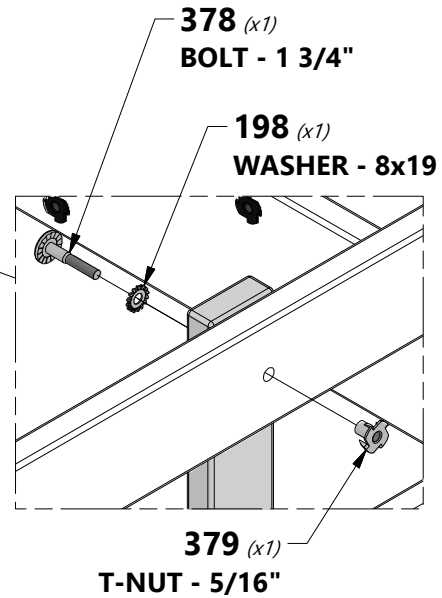

378 (x1)
BOLT - 1 3/4"

198 (x1)
WASHER - 8x19

379 (x1)
T-NUT - 5/16"

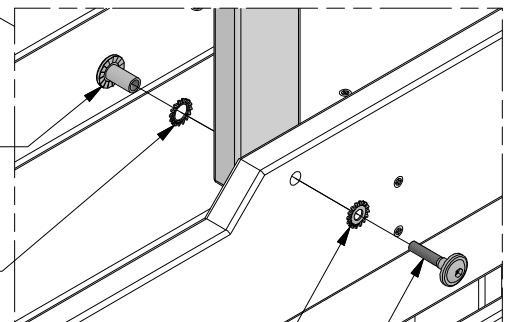

192 (x1)
NUT BARREL - 7/8"

199 (x1)
WASHER - 12x19

198 (x1)
WASHER - 8x19

407 (x1)
BOLT - 1 1/2"



Phase 1

STEP 40

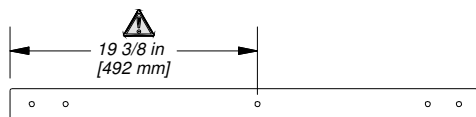

J3 | WALL UPRIGHT - W4L12396
(x1) | 1"x2 3/8"x36 1/2" (24x60x927)



A100340 | L BRACKET 2.5x38x50x55
(x1)



H100378 | BOLT WH BLK
(x2) | 5/16x1 3/4



H100396 | BOLT WH BLK
(x2) | 5/16x1/2



H100192 | NUT BARREL WH BLK
(x1) | 5/16x7/8



H100198 | WASHER LOCK EXT BLK
(x2) | 8x19



H100379 | T-NUT BLK
(x3) | 5/16



H100199 | WASHER LOCK EXT BLK
(x1) | 12x19



ASSEMBLY TIP:

THE BRACKET ORIENTATION IS CRITICAL. PLEASE ORIENTATE WITH DIMENSION BELOW AS SHOWN.

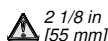

REAR VIEW

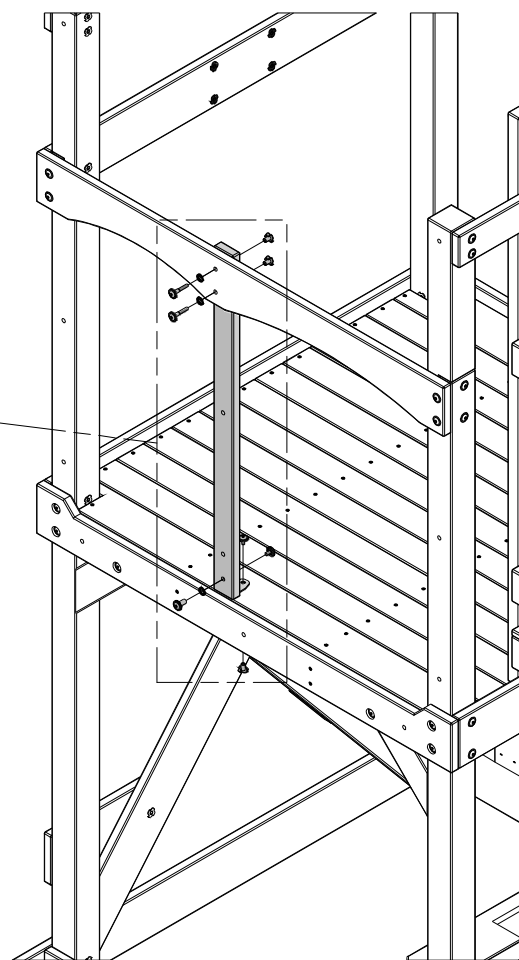
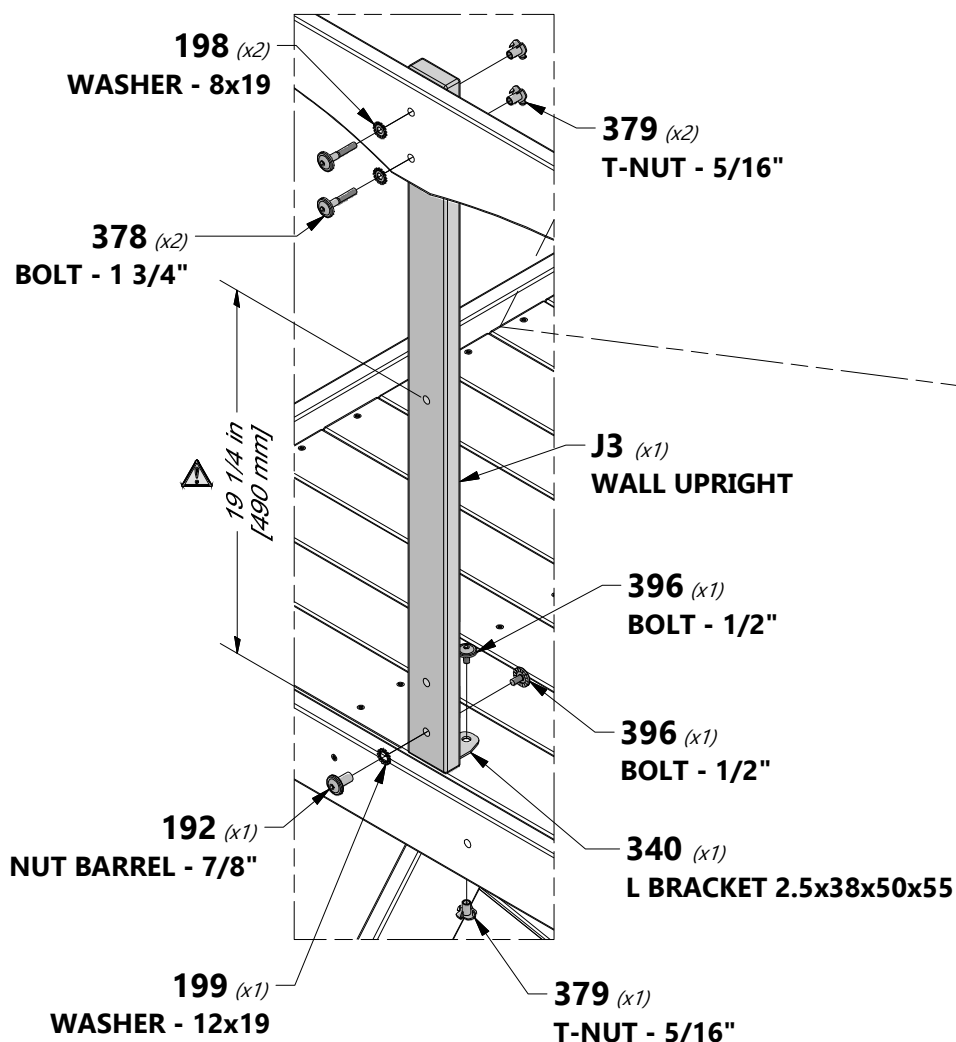
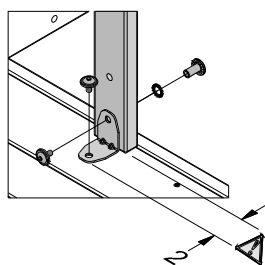

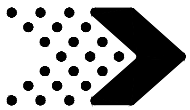

Phase 2

STEP 1

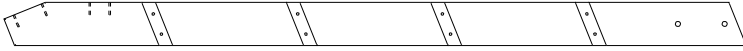

E6 | LEFT UPRIGHT - W4L12490
(x1) | 1 3/8"x3 3/8"x58" (36x86x1474)



H16 | LADDER RUNG - W4L12492
(x4) | 1"x3 3/8"x19 1/4" (24x86x489)

H100201 | SCREW PFH BLK
(x8) | 8x2-1/2

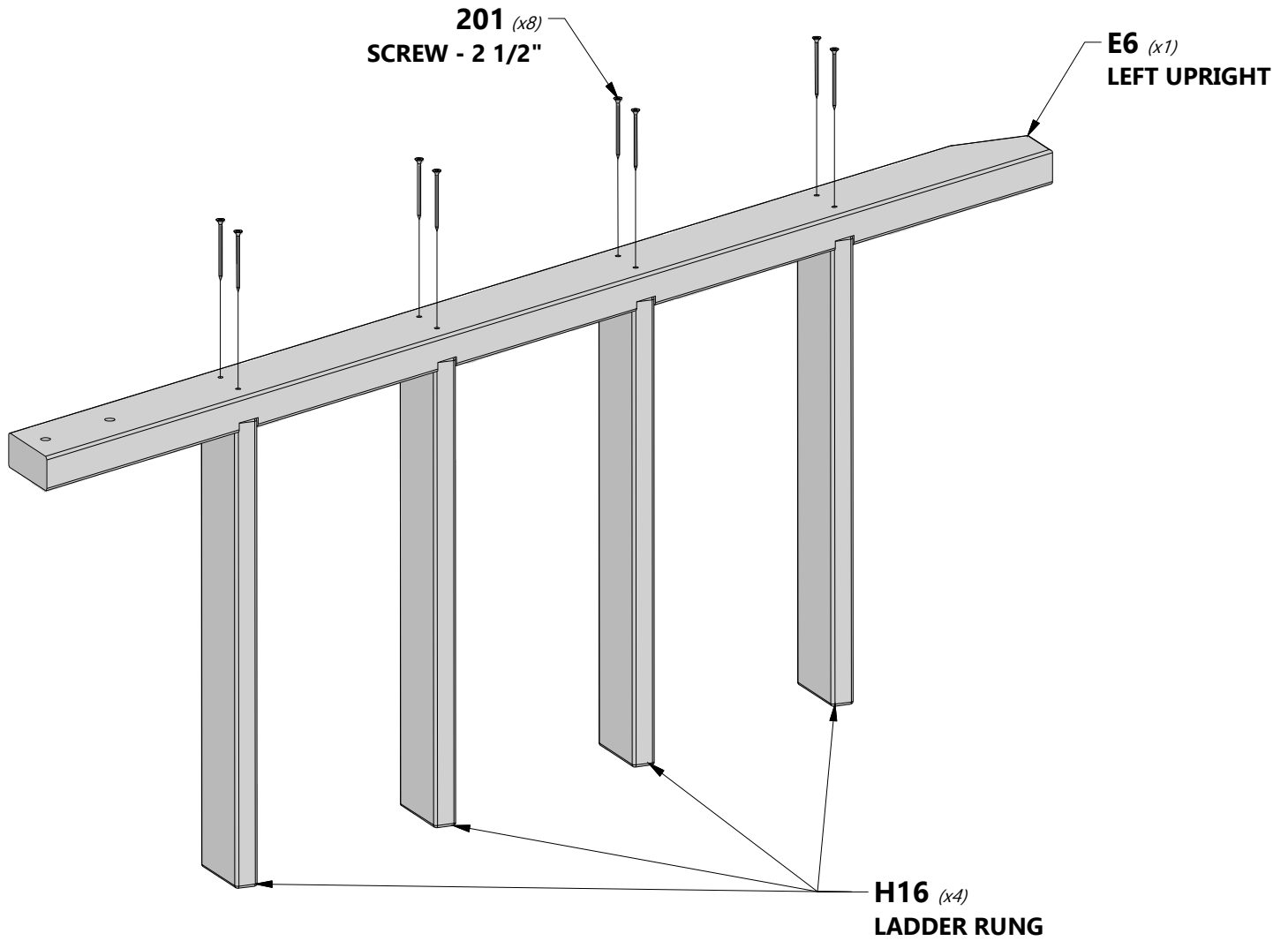

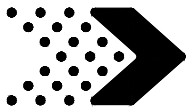

Phase 2

STEP 2

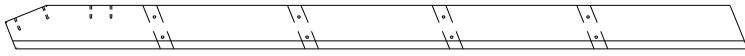

E7 | **MIDDLE UPRIGHT - W4L12491**
(x1) | 1 3/8"x3 3/8"x58" (36x86x1474)



H100201 | **SCREW PFH BLK**
(x8) | 8x2-1/2

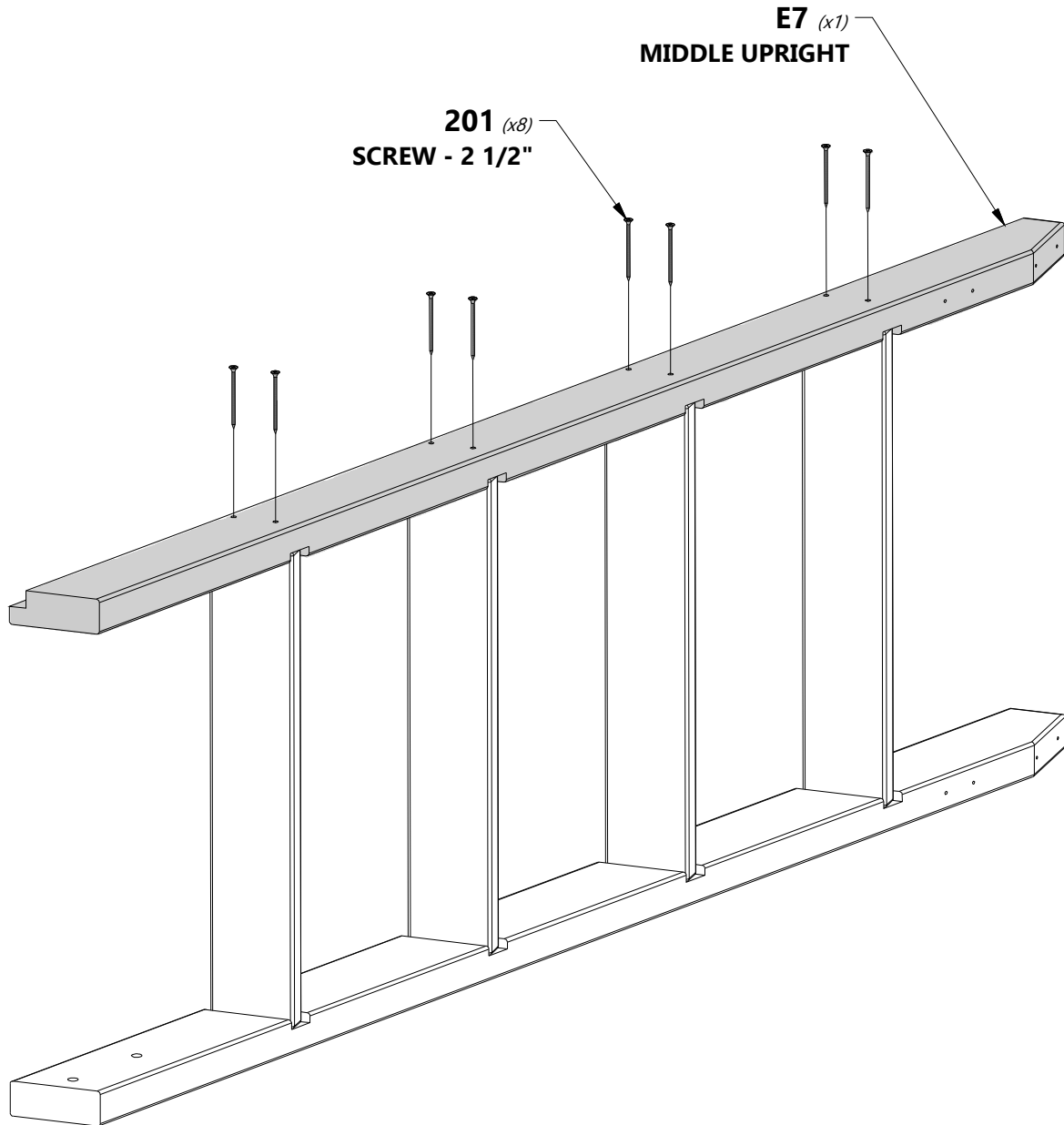



Phase 2

STEP 3



M12 | **REAR SUPPORT - W4L12493**
(x1) | 5/8"x3 3/8"x21 1/4" (16x86x541)



H100200 | **SCREW PFH BLK**
(x4) | 8x1 1/2

200 (x4)
SCREW - 1 1/2"

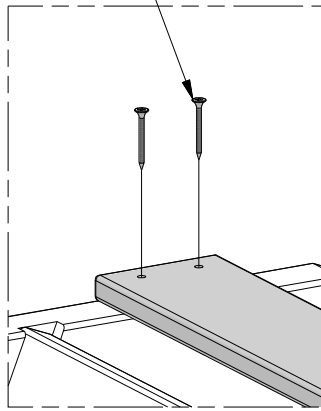

M12 (x1)
REAR SUPPORT

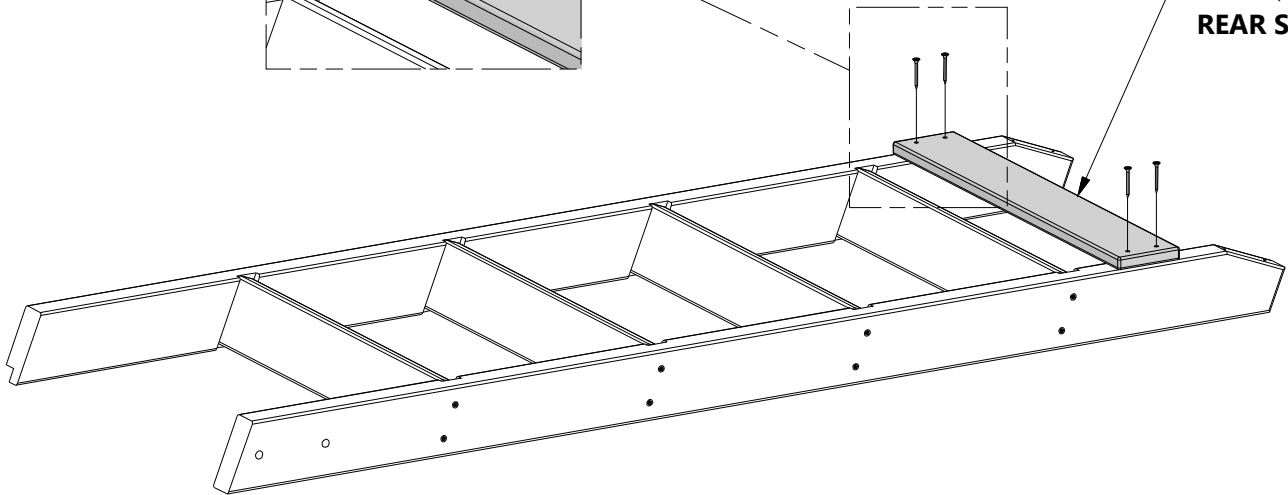

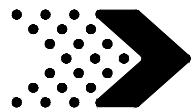

Phase 2

STEP 4

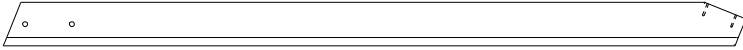

E8 | **RIGHT UPRIGHT - W4L12495**
(x1) | 1 3/8"x3 3/8"x58" (36x86x1474)



Y2 | **ATTACHMENT BOARD - W4L12494**
(x1) | 5/8"x4"x49 1/8" (16x102x1248)



H100391 | **SCREW PFH BLK**
(x6) | 8x2



H100379 | **T-NUT BLK**
(x2) | 5/16



ASSEMBLY NOTE:
ADD T-NUTS AS SHOWN
PRIOR TO INSTALLING THE
Y2 BOARD.

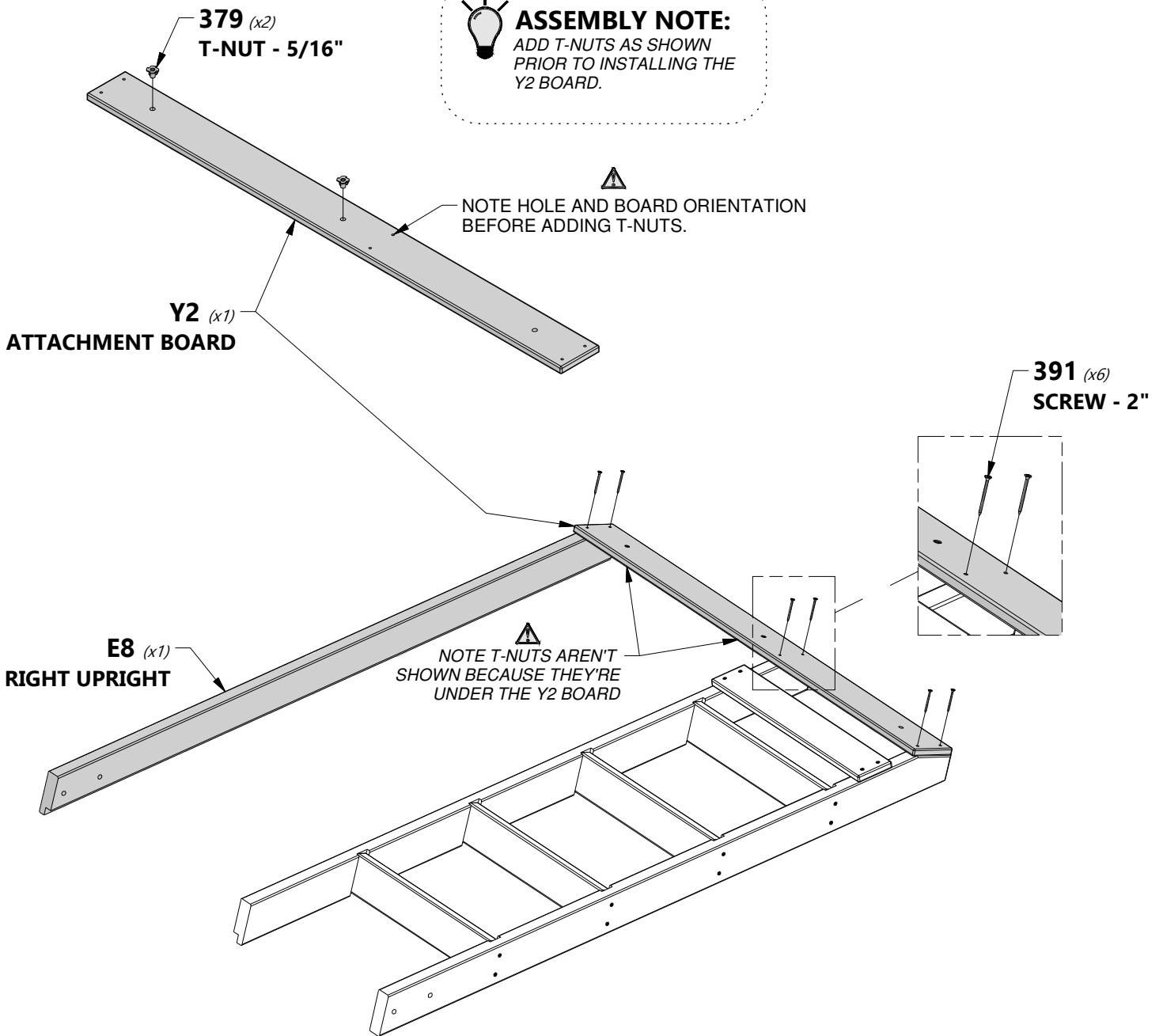



Phase 2

STEP 5



N4 | ROCK BOARD - W4L12499
(x1) | 5/8"x2 3/8"x27 3/4" (16x60x706)

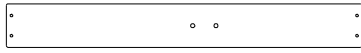

M14 | ROCK BOARD - W4L12497
(x4) | 5/8"x3 3/8"x27 3/4" (16x86x706)



M13 | ROCK BOARD - W4L12496
(x8) | 5/8"x3 3/8"x27 3/4" (16x86x706)

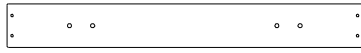

M15 | ROCK BOARD - W4L12498
(x4) | 5/8"x3 3/8"x27 3/4" (16x86x706)



H100398 | T-NUT BLK
(x24) | 1/4"



H100200 | SCREW PFH BLK
(x68) | 8x1 1/2"

PREPARATION: INSTALL T-NUTS

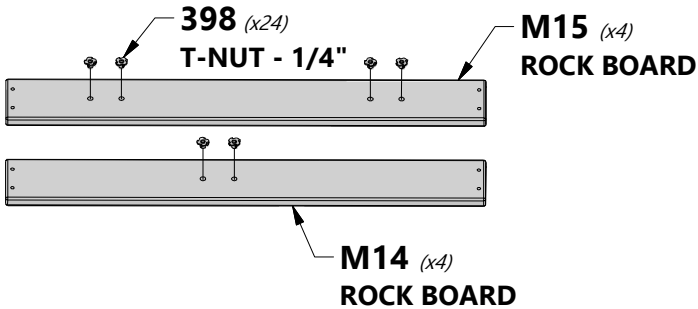

ASSEMBLY NOTE:
USE THE FOLLOWING REPEATING PATTERN TO BUILD THE ROCKWALL. BEGINNING AT THE TOP THE PATTERN IS M13, M15, M13, M14. REPEAT 4 TIMES AND END WITH N4 BOARD. MAKE SURE TO PLACE EACH M14 BOARD SO THE HOLES ALTERNATE RIGHT TO LEFT OF CENTER.

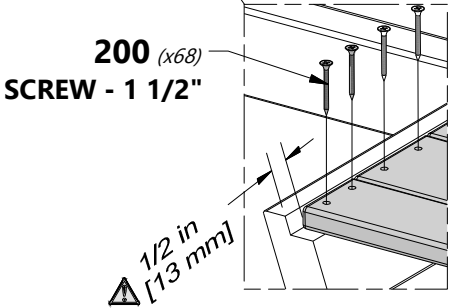
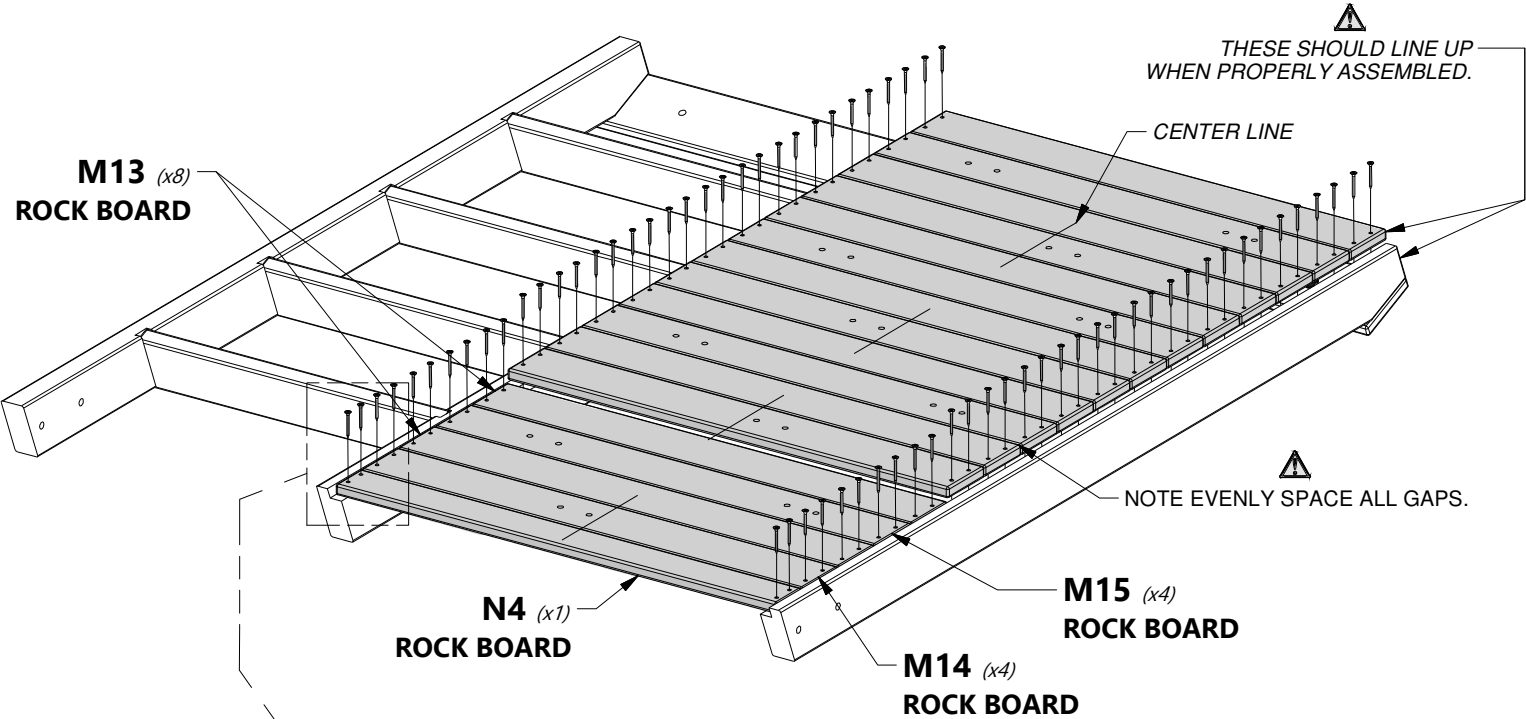

ASSEMBLY TIP:
IT CAN HELP TO SET ALL THE BOARDS IN PLACE TO MAKE SURE THEY MATCH THE DIAGRAM PRIOR TO MOUNTING THEM WITH THE PROVIDED SCREWS.

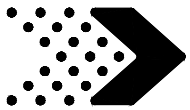

Phase 2

STEP 6



N5 | **ROCKWALL CLEAT - W4L12965**
(x1) | 5/8"x2 3/8"x54 1/2" (16x60x1385)



H100380 | **SCREW PFH BLK**
(x11) | 8x1 1/8



ASSEMBLY TIP:
PLACE AND CENTER N5
BOARD AS SHOWN.

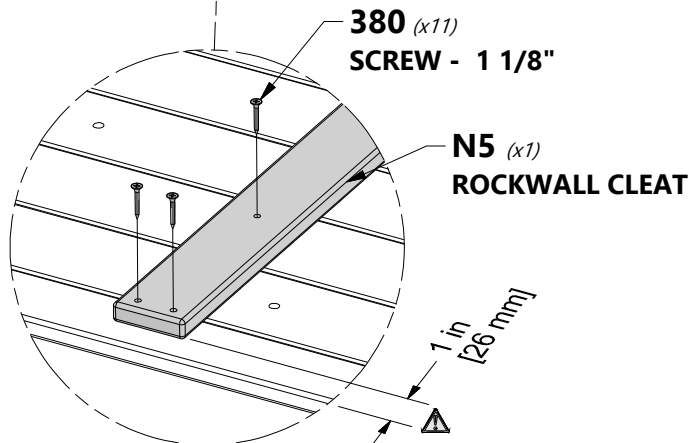
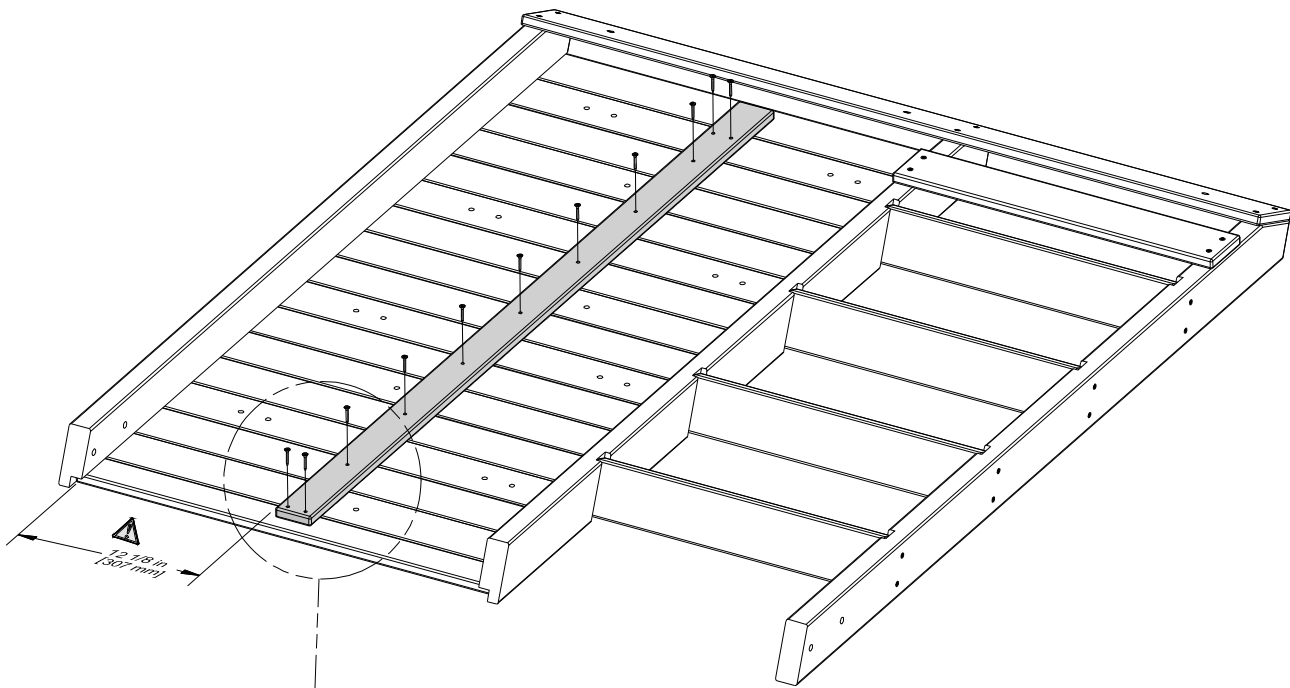

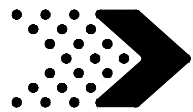

Phase 2

STEP 7



A6P00037 | GREEN HC ROCK #2
(x12)

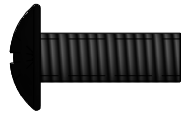

H100489 | BOLT PTH BLK
(x24) | 1/4x3/4

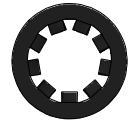

H100473 | WASHER LOCK INT BLK
(x24) | 8x15



NOTE ARROW SHOULD FACE UP.

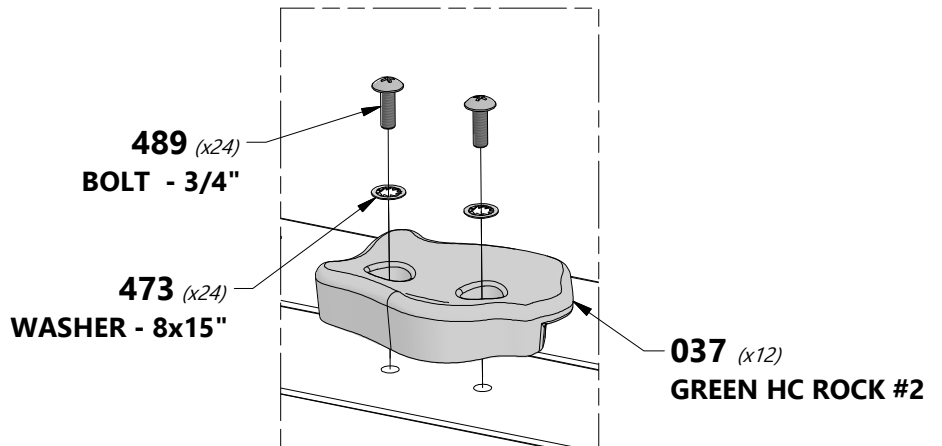

ASSEMBLY TIP:

INSTALL ROCKS USING THE SHOWN HARDWARE WITH THE T-NUTS THAT WERE PRE-INSTALLED FROM STEP 5 OF THIS PHASE.

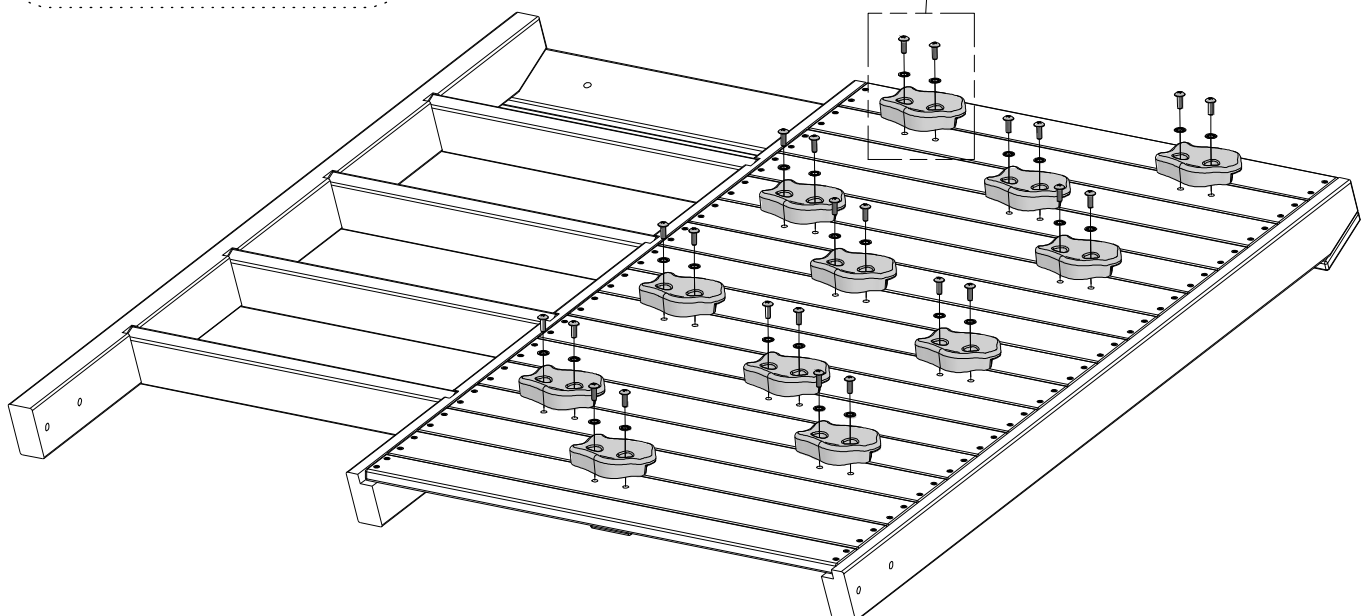

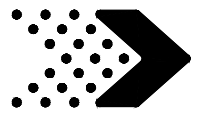

Phase 2

STEP 8

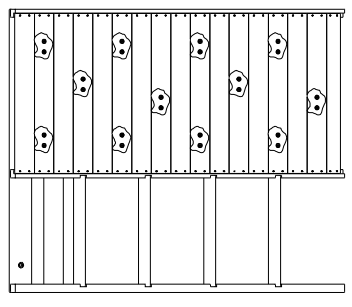

ROCK WALL ASSEMBLY FROM THE PREVIOUS STEP



H100205 | BOLT WH BLK (x4) | 5/16x2-1/4



H100198 | WASHER LOCK EXT BLK (x7) | 8x19



H100379 | T-NUT BLK (x4) | 5/16



H100468 | BOLT WH BLK (x1) | 5/16x1



H100199 | WASHER LOCK EXT BLK (x1) | 12x19

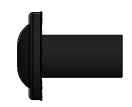

H100192 | NUT BARREL WH BLK (x1) | 5/16x7/8

H100407 | BOLT WH BLK (x2) | 5/16x1 1/2

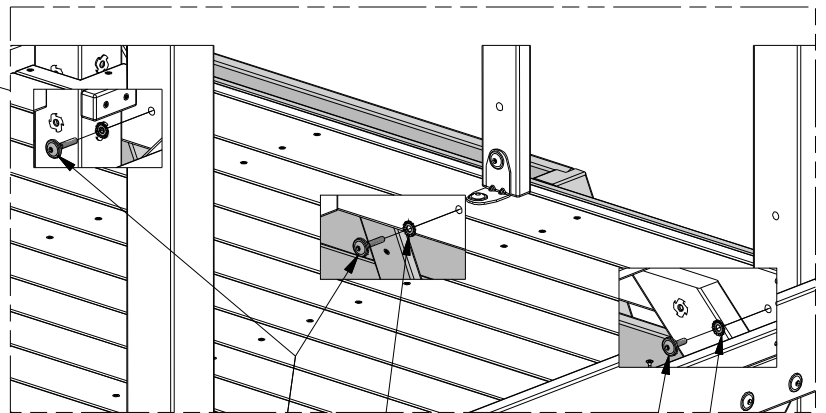
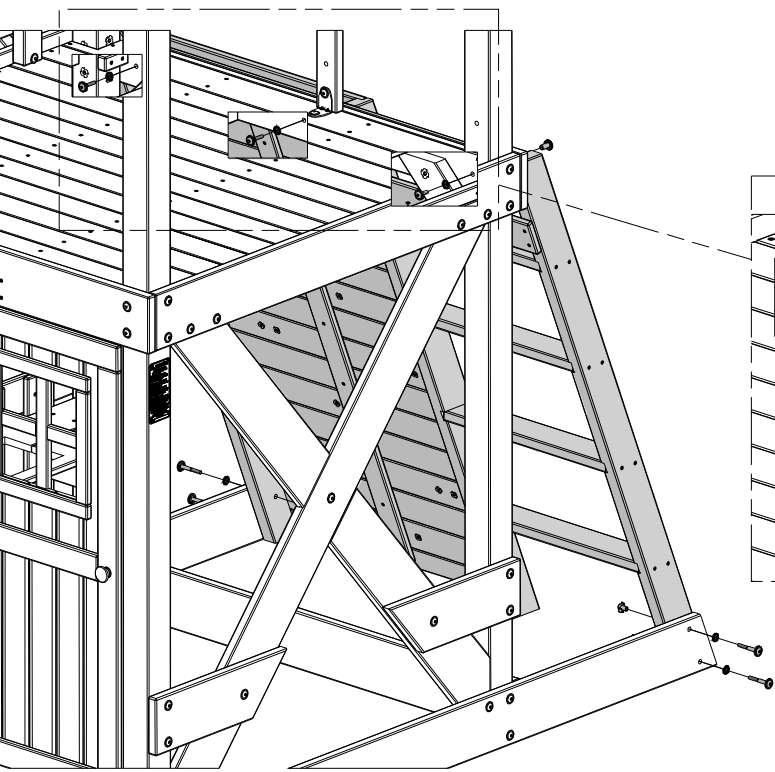
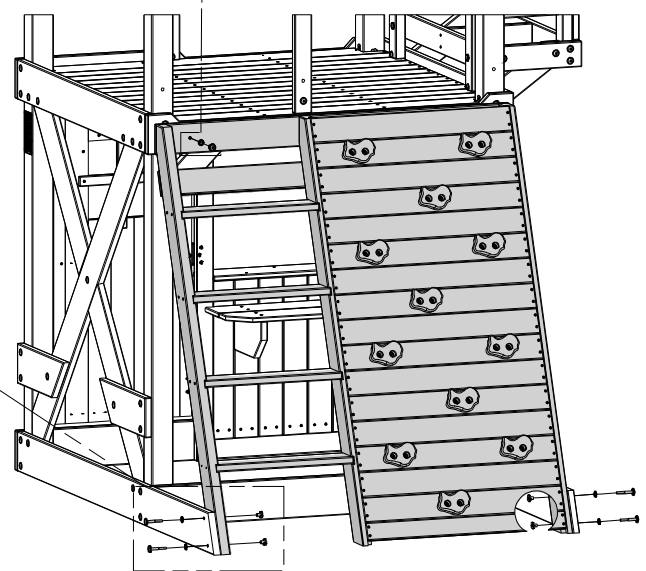
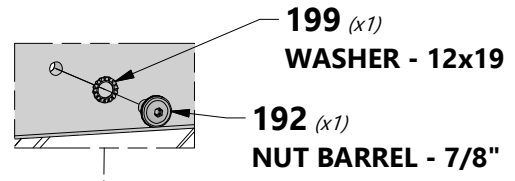
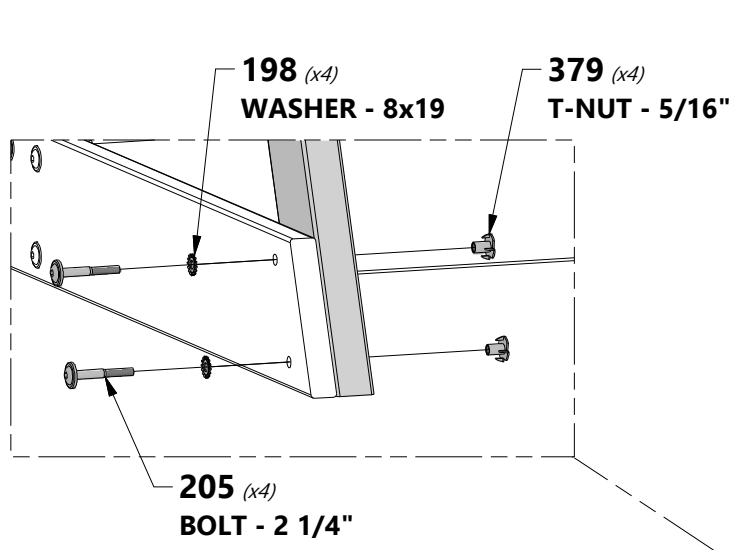

407 (x2) BOLT - 1 1/2"

468 (x1) BOLT WH - 1"

198 (x2) WASHER - 8x19

198 (x1) WASHER - 8x19

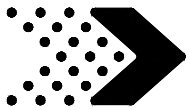

Phase 3

STEP 1

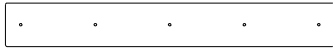

H8 | **TOP RAIL BOARD - W4L12417**
(x1) | 1"x3 3/8"x25 5/8" (24x86x652)



H100200 | **SCREW PFH BLK**
(x5) | 8x1 1/2

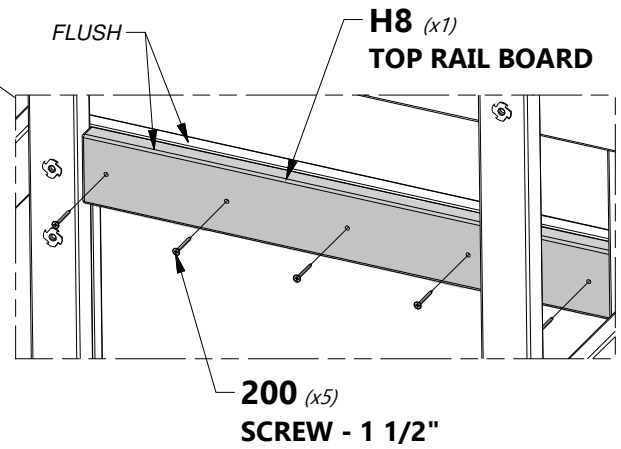
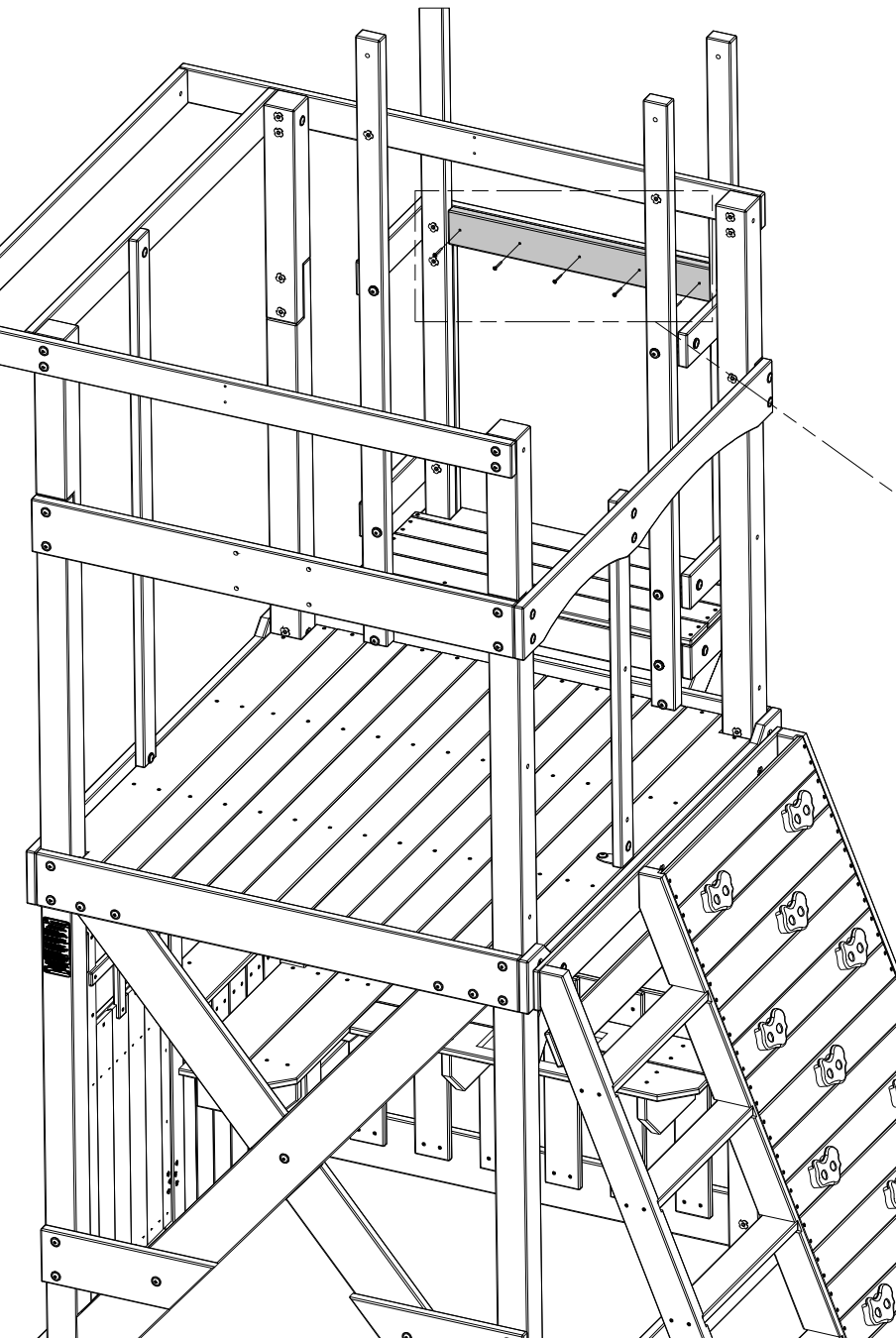

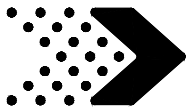

Phase 3

STEP 2



K1 | **WALL BOARD - W4L12399**
(x2) | 5/8"x5 1/4"x52 3/8" (16x134x1329)



H100380 | **SCREW PFH BLK**
(x8) | 8x1 1/8

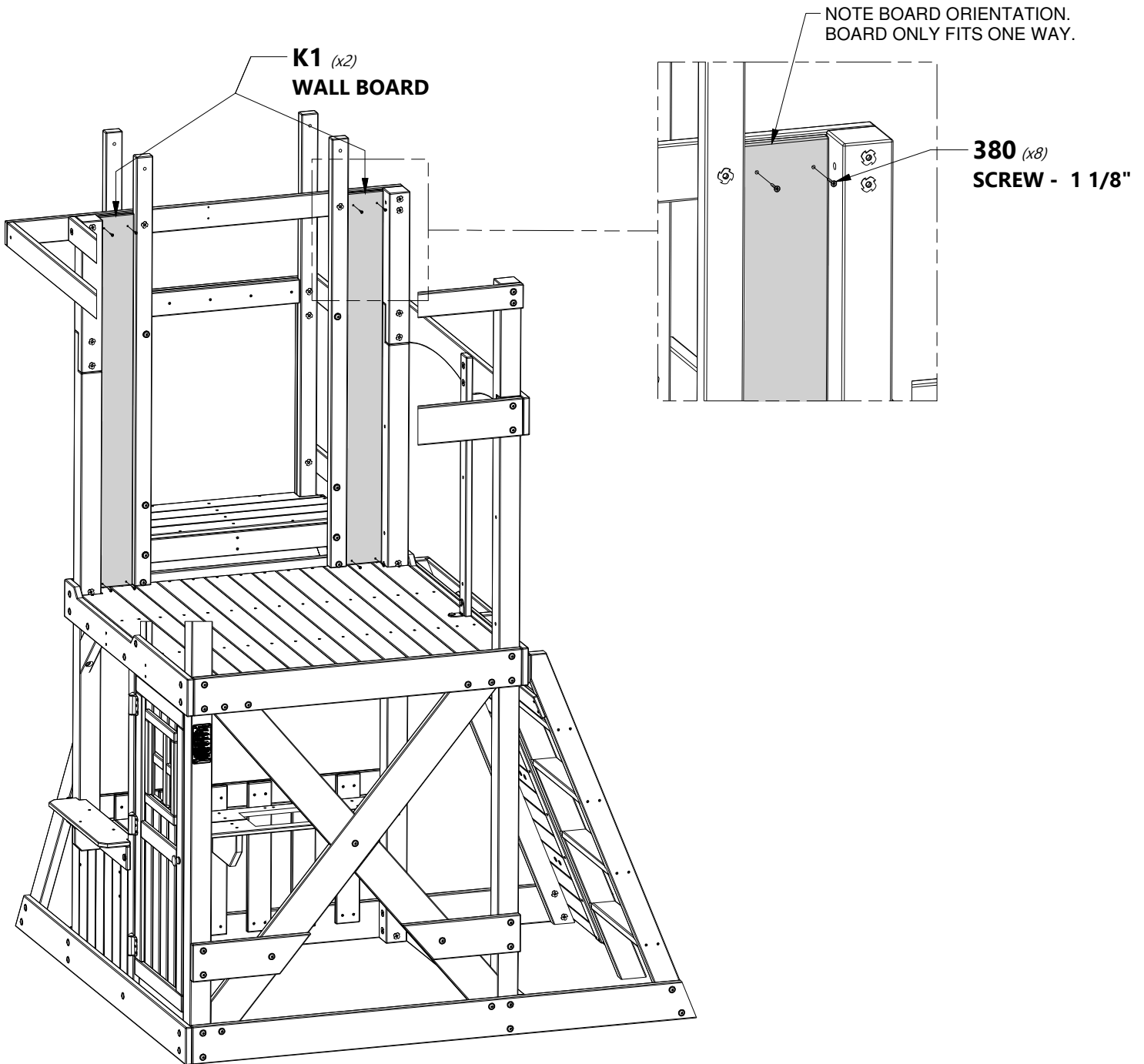

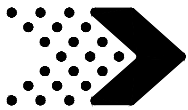

Phase 3

STEP 3

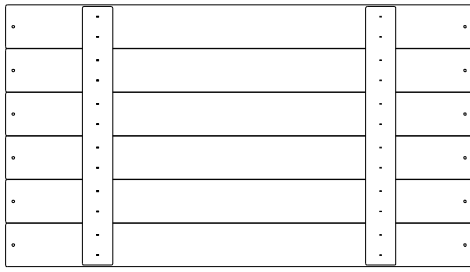

WP2 | WALL PANEL - W2A02751
(x2) | 1 1/16"x20 7/16"x36 1/2" (27x519x927)



H100380 | SCREW PFH BLK
(x24) | 8x1 1/8"

WP2 (x1)
WALL PANEL

WP2 (x1)
WALL PANEL

380 (x24)
SCREW - 1 1/8"

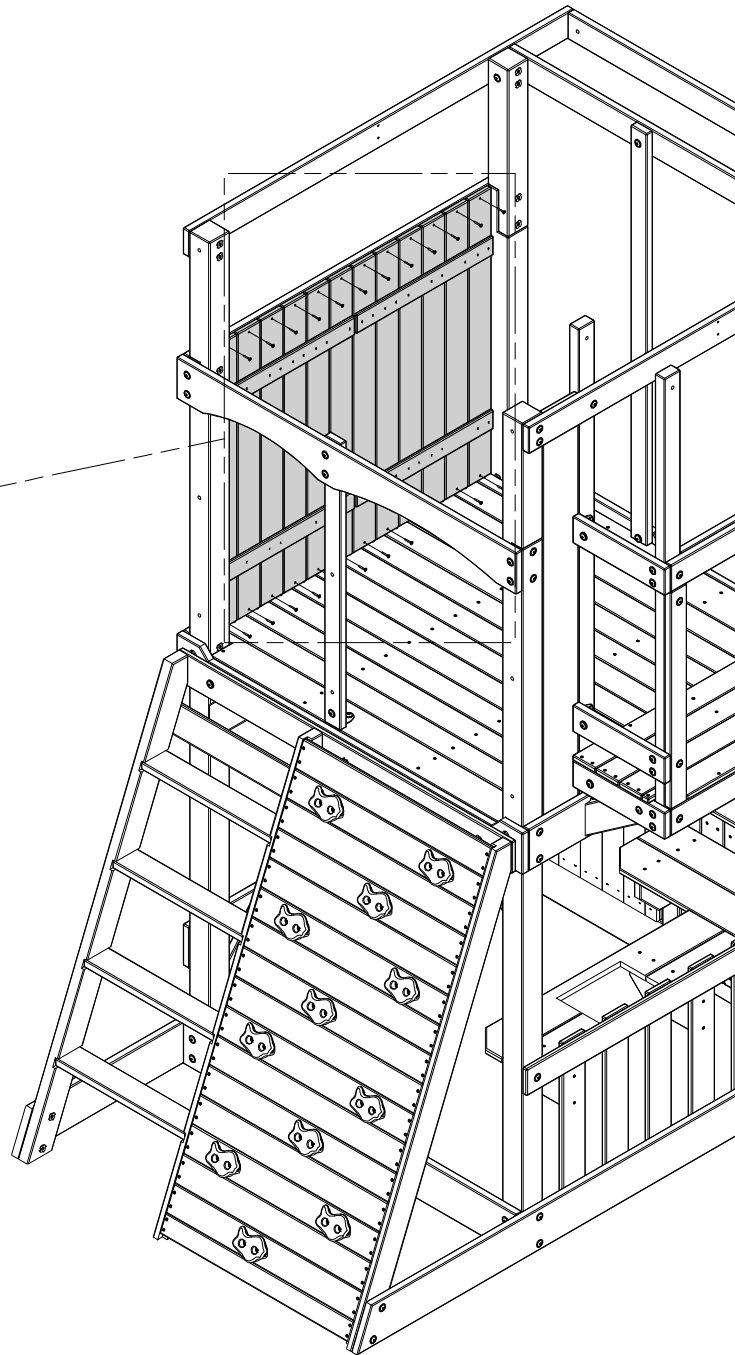
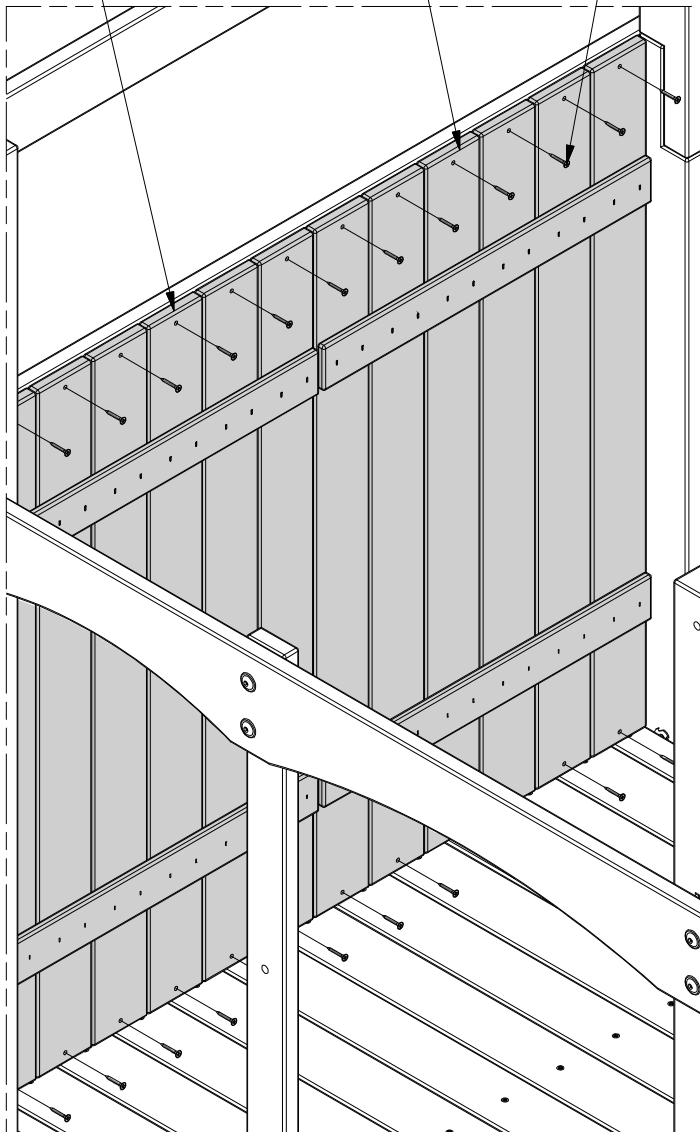

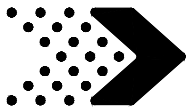

Phase 3

STEP 4

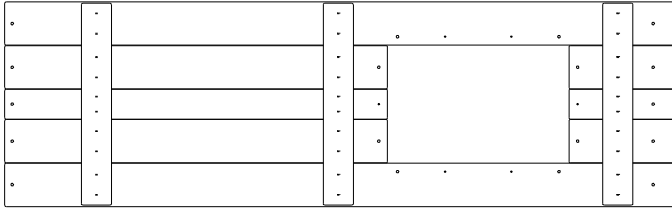

WP1 | WALL PANEL - W2A02748
(x1) | 1 1/16"x15 15/16"x52 3/8" (27x405x1331)



H100380 | SCREW PFH BLK
(x10) | 8x1 1/8"

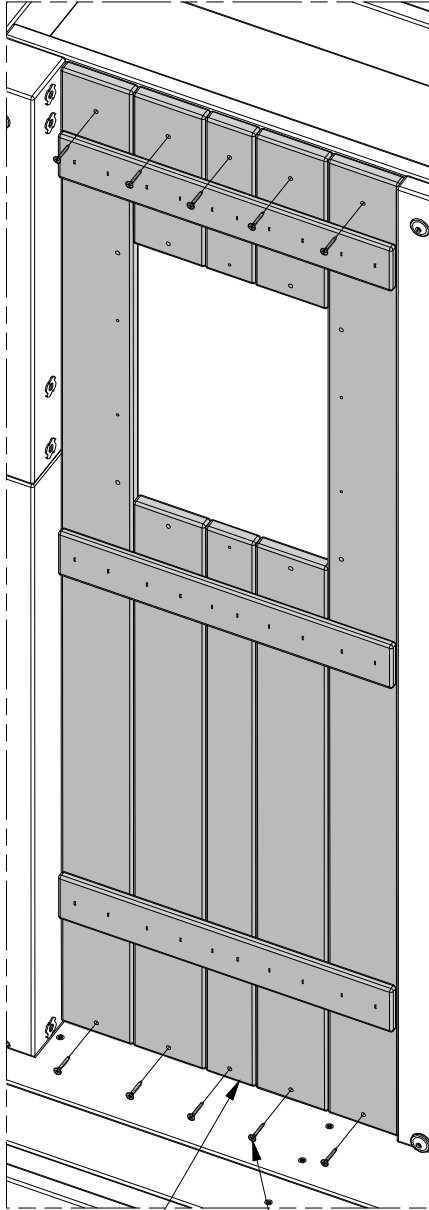

WP1 (x1)
WALL PANEL

380 (x10)
SCREW - 1 1/8"

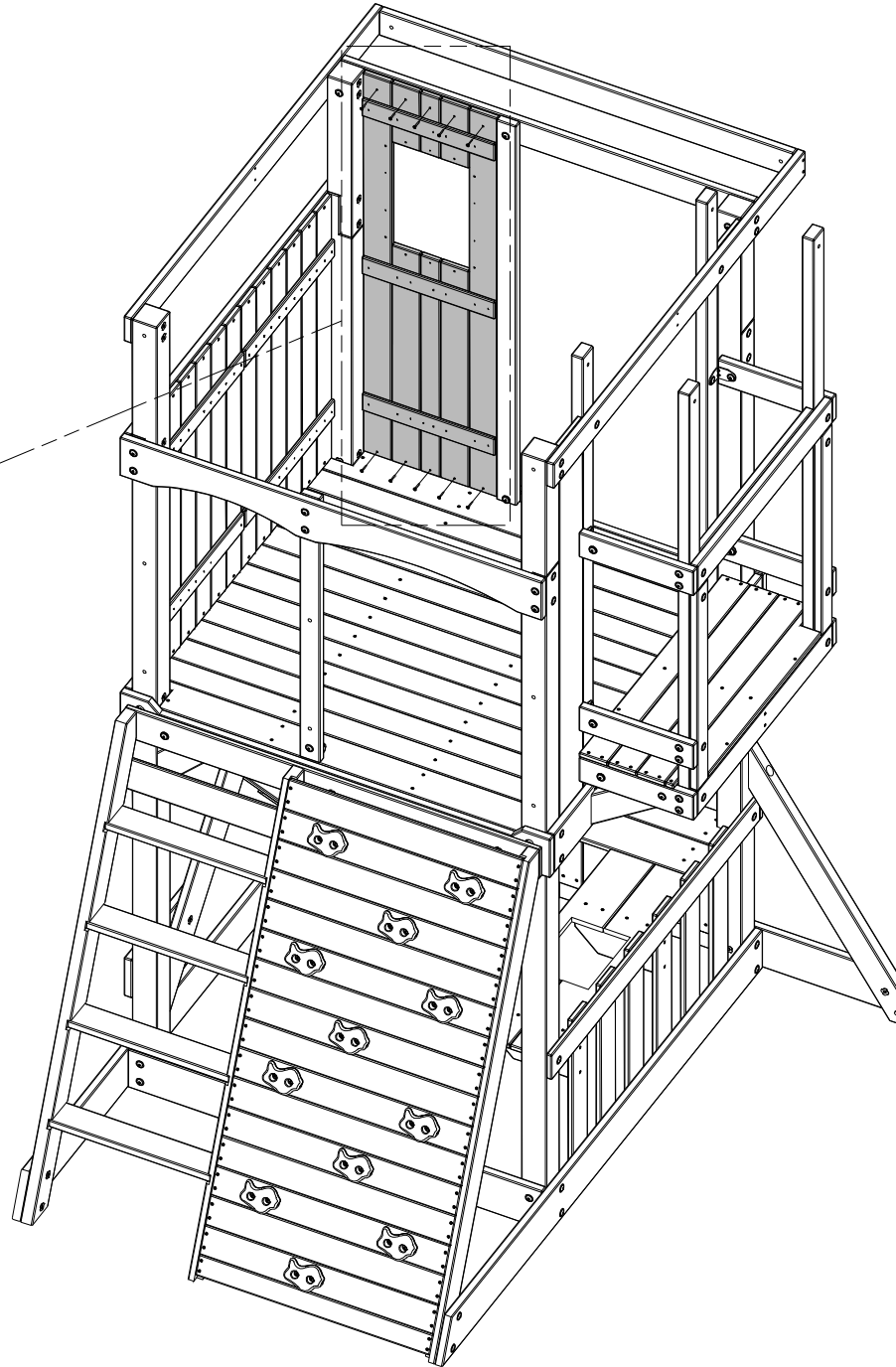

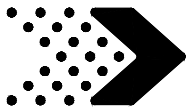

Phase 3

STEP 5

T3 | WINDOW FRAME - W4L12421
(x1) | 1"x1 3/8"x16 7/8" (24x34x429)

O1 | WINDOW TRIM - W4L12419
(x2) | 5/8"x1 3/8"x14 1/4" (16x34x361)

H100395 | SCREW PFH BLK
(x2) | 8x3/4

H100816 | SCREW PFH BLK
(x8) | 8x7/8

T4 | WINDOW FRAME - W4L12422
(x2) | 1"x1 3/8"x11 7/8" (24x34x301)

O2 | WINDOW TRIM - W4L12420
(x2) | 5/8"x1 3/8"x11 7/8" (16x34x301)

H100200 | SCREW PFH BLK
(x6) | 8x1 1/2

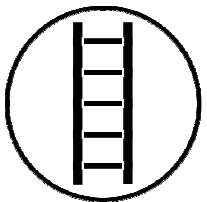
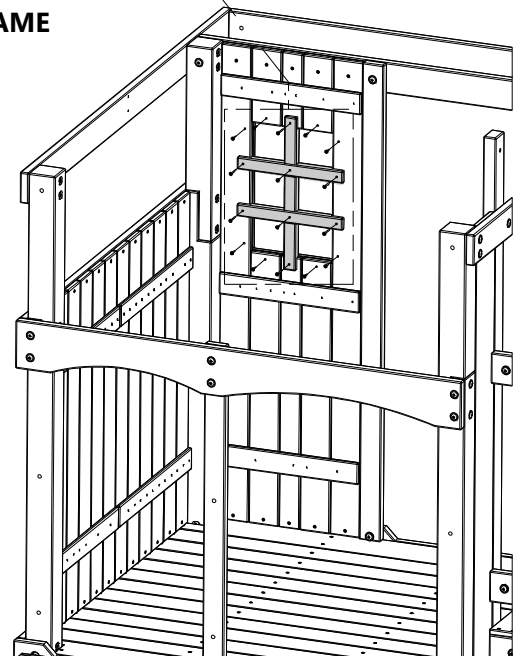
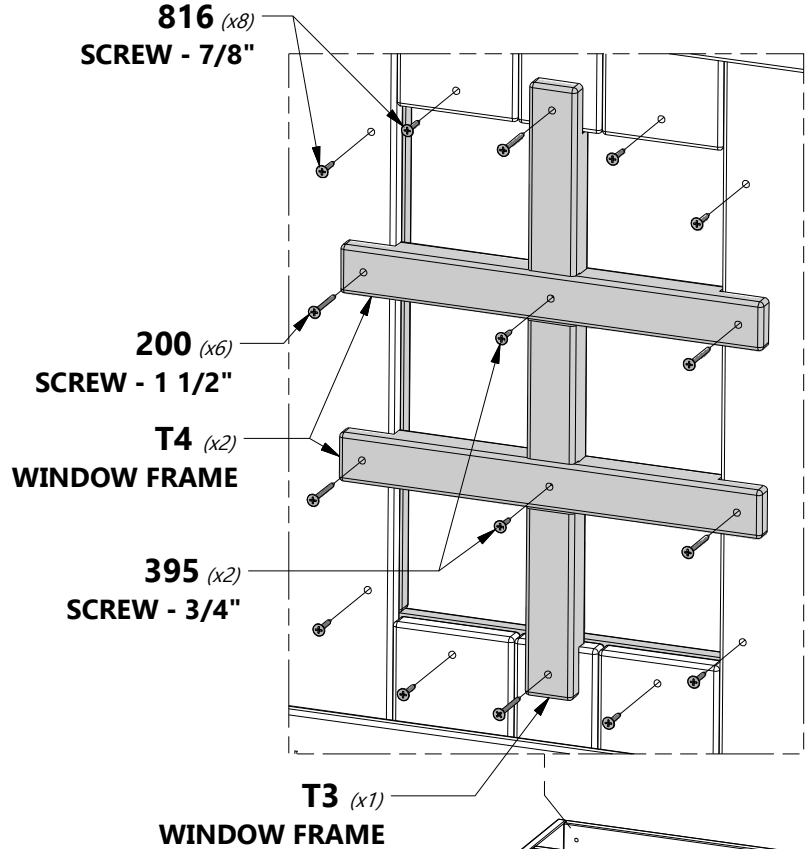
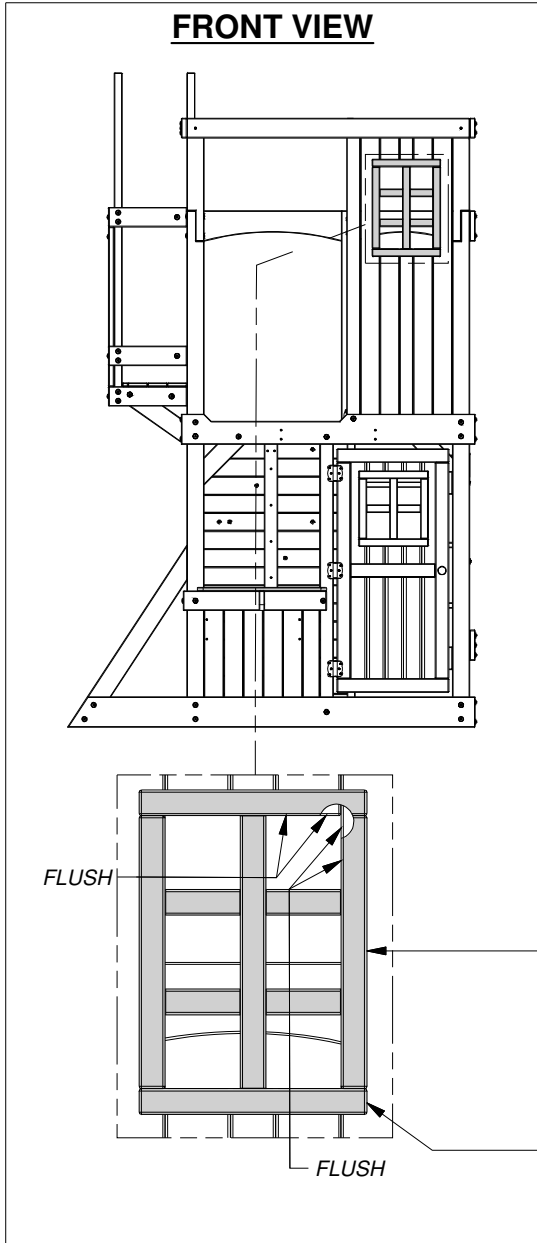



Phase 3

STEP 6



N1 | **UPPER PICKET - W4L12416**
(x4) | 5/8"x2 3/8"x26 1/4" (16x60x666)



H100380 | **SCREW PFH BLK**
(x16) | 8x1 1/8

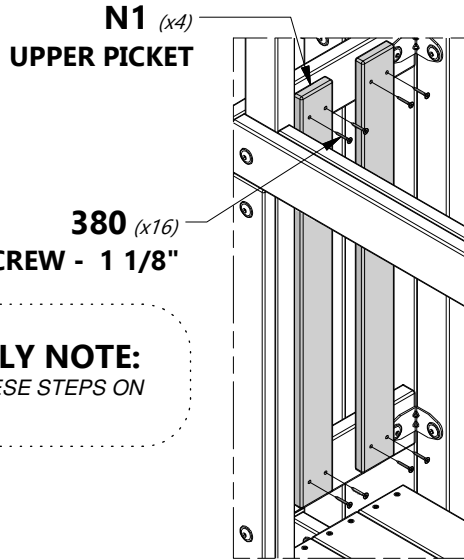

ASSEMBLY NOTE:
FOLLOW THESE STEPS ON
BOTH SIDES.

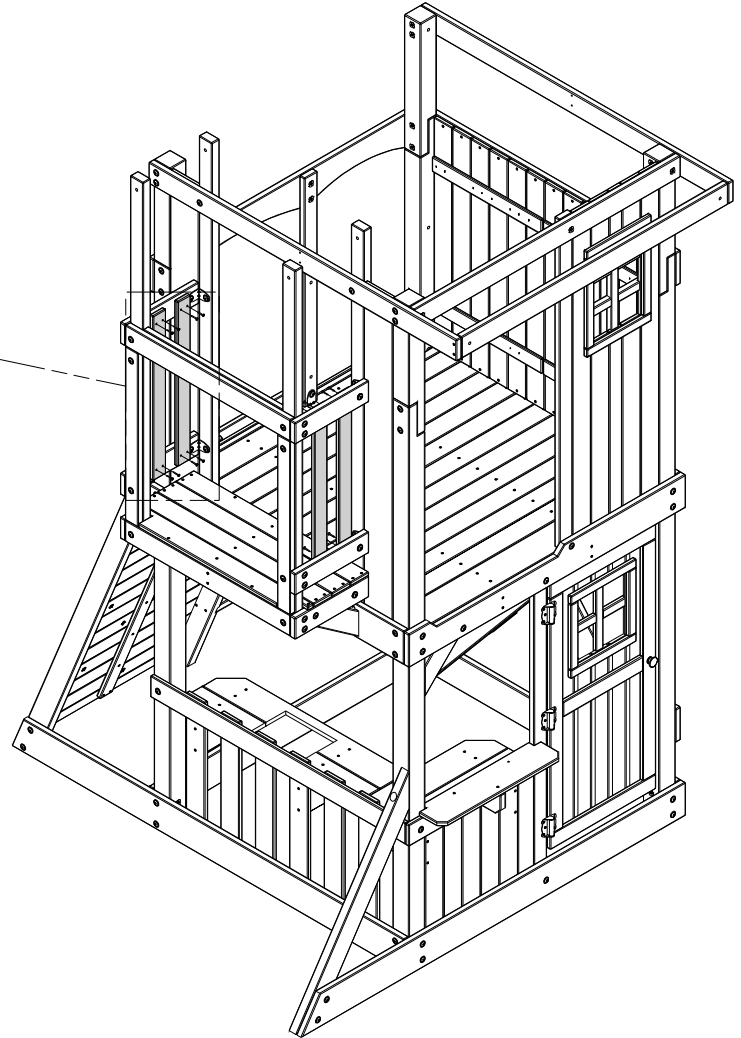

INSIDE VIEW

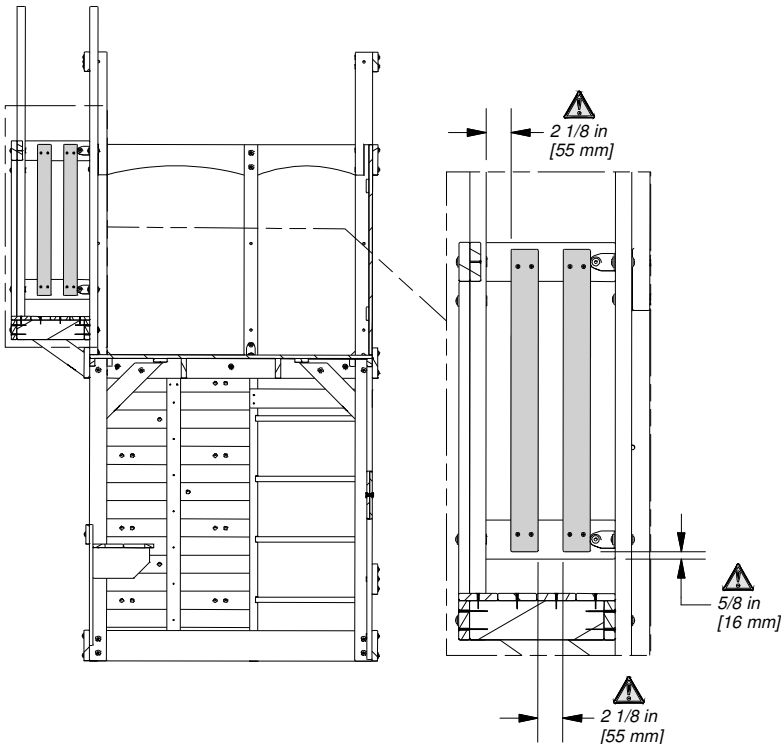

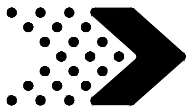

Phase 3

STEP 7



L1 | **FACIA - W4L12431**
(x1) | 5/8"x4 3/8"x51" (16x112x1296)



K8 | **FACIA - W4L12430**
(x1) | 5/8"x5 1/4"x51" (16x134x1296)



H100200 | **SCREW PFH BLK**
(x12) | 8x1 1/2

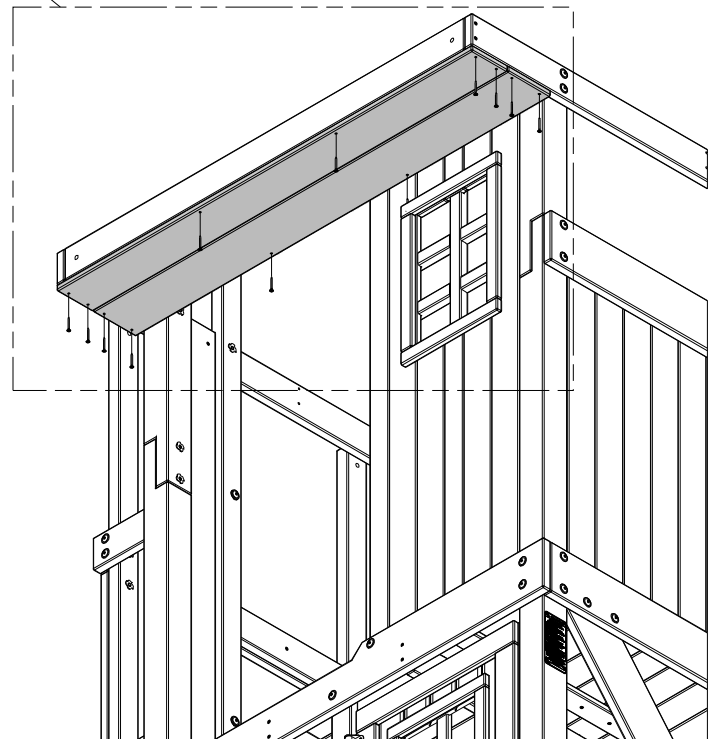
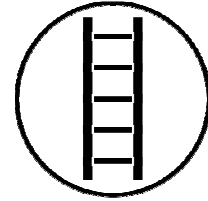
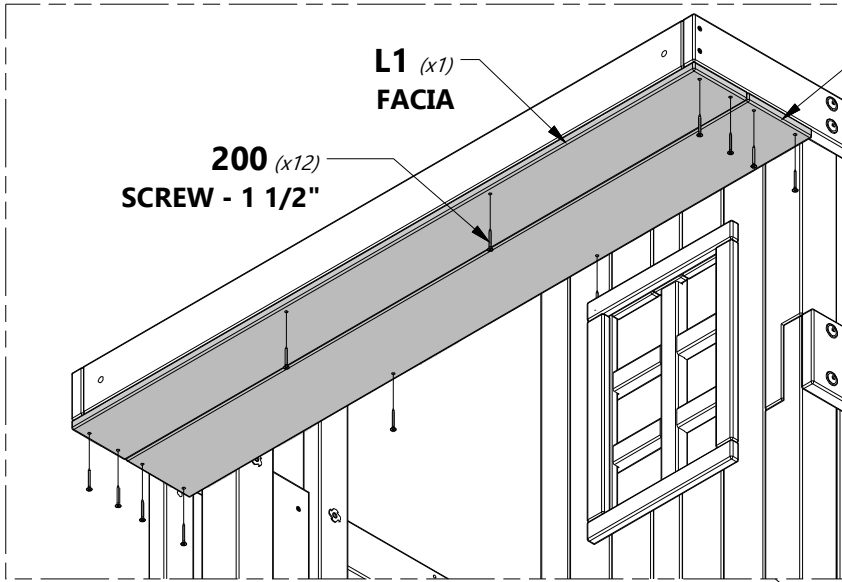

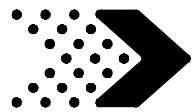



Phase 4

STEP 1

N3 | ROOF CLEAT - W4L12433
 (x1) | 5/8"x2 3/8"x3 15/16" (16x60x100)

H14 | ROOF JOIST - W4L12432
 (x2) | 1"x3 3/8"x30 3/8" (24x86x770)

H100387 | SCREW PFH BLK
 (x4) | 8x1-1/4



H100382 | SCREW PFH BLK
 (x4) | 8x1 3/4



ASSEMBLY TIP:

OPTION: IF YOU DON'T HAVE A HELPER YOU CAN ASSEMBLE THE ROOF JOISTS ON THE GROUND FORMING THE PEAK AND THEN MOUNT IT TO THE FORT.

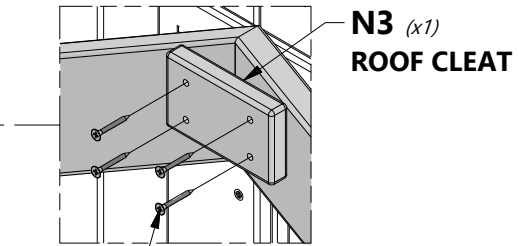
H14 (x1)
ROOF JOIST



387 (x4)
SCREW - 1 1/4"

H14 (x1)
ROOF JOIST

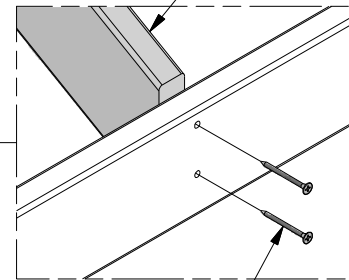

382 (x4)
SCREW - 1 3/4"

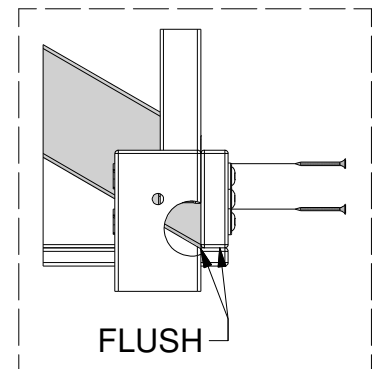

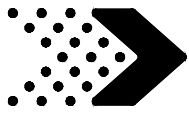

Phase 4

STEP 2

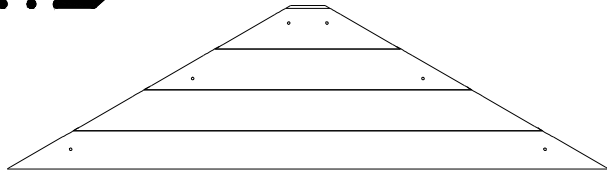

GP1 | **GUSSET PANEL - W2A02752**
(x2) | 5/8"x47"x12 3/4" (16x1194x324)

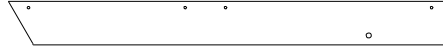

M16 | **FACIA BOARD - W4L12967**
(x4) | 5/8"x3 3/8"x34 5/8" (16x86x880)



H100380 | **SCREW PFH BLK**
(x12) | 8x1 1/8

DO THESE STEPS TWICE



TIP:

FOR EASE OF ASSEMBLY: LAY M16 BOARDS ON LEVEL GROUND AND ALIGN A GP1 PANEL ON TOP. MATCH THE MEASUREMENTS SHOWN AND ASSEMBLE.

MAKE SURE THE CORNERS OR POINTS ALIGN AS SHOWN.

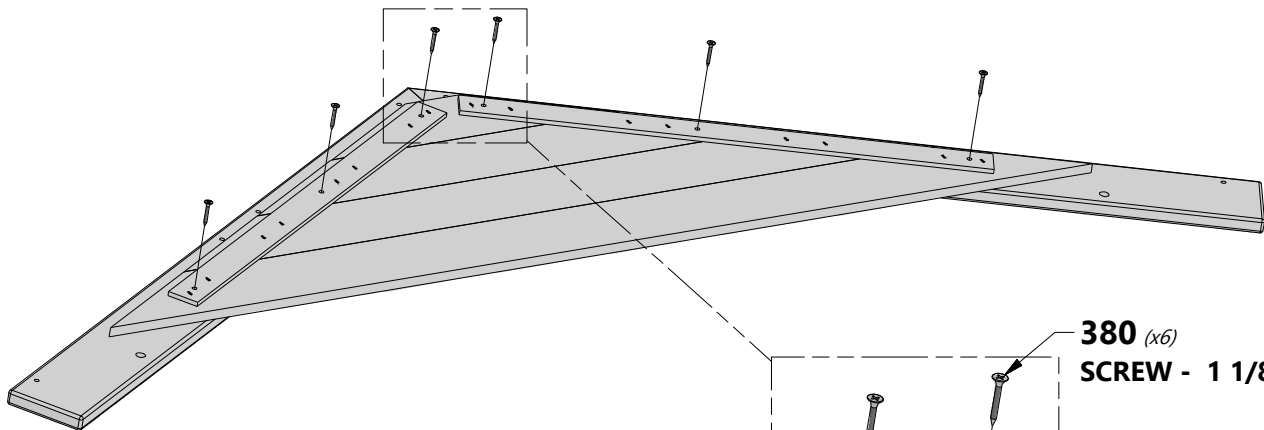
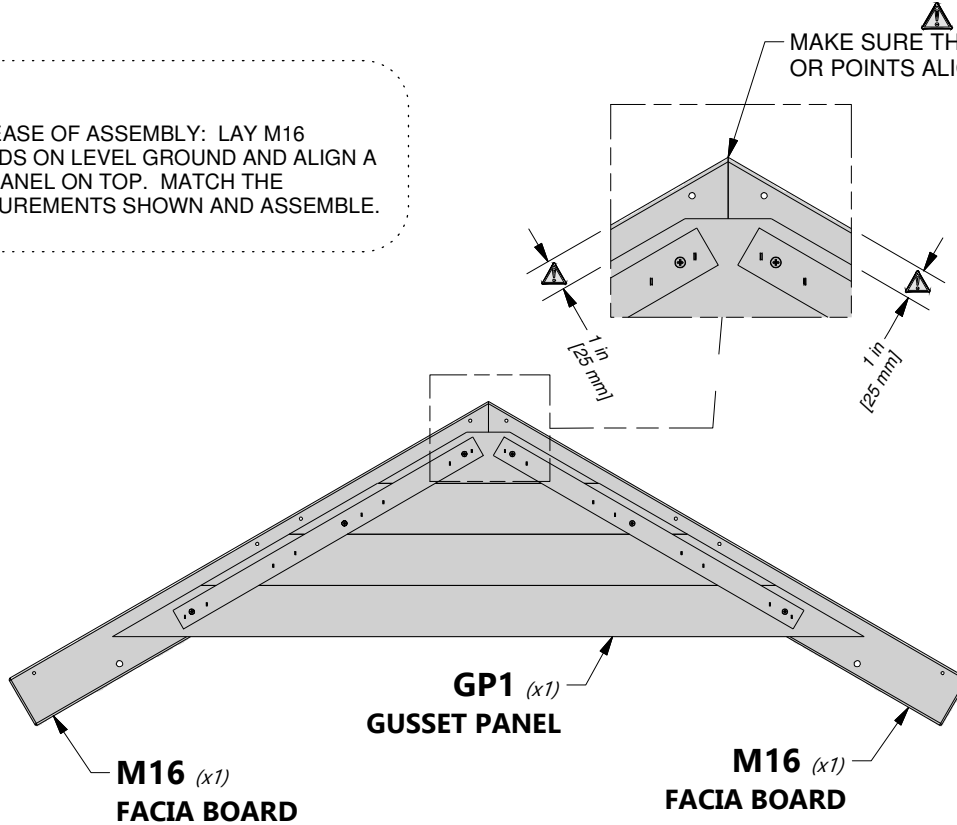

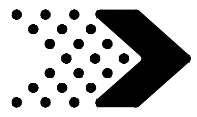

Phase 4

STEP 3

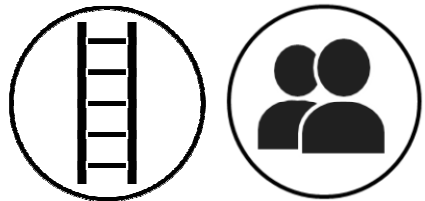
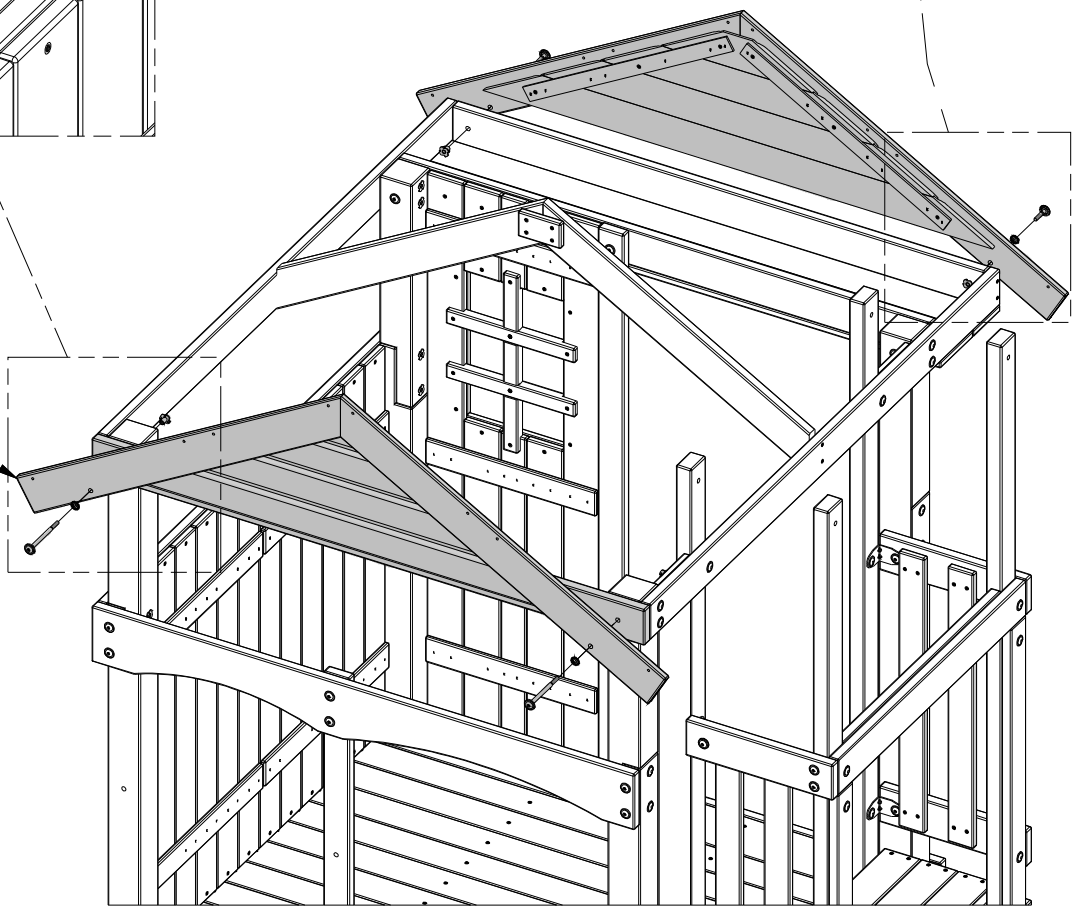
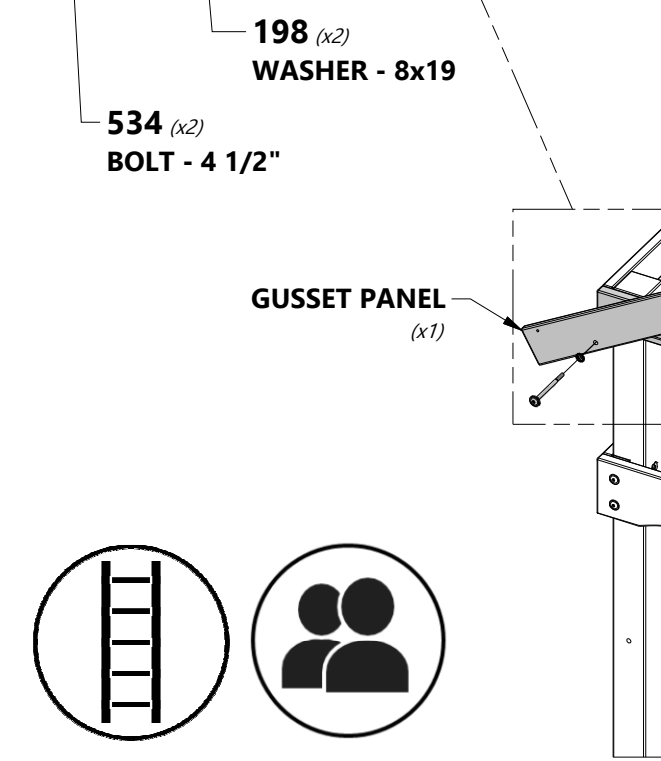
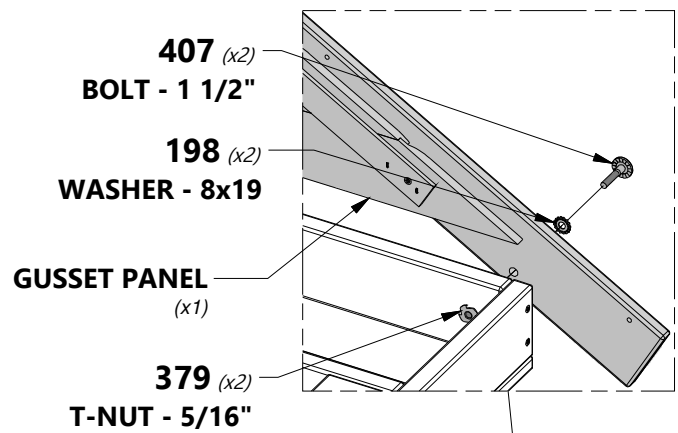
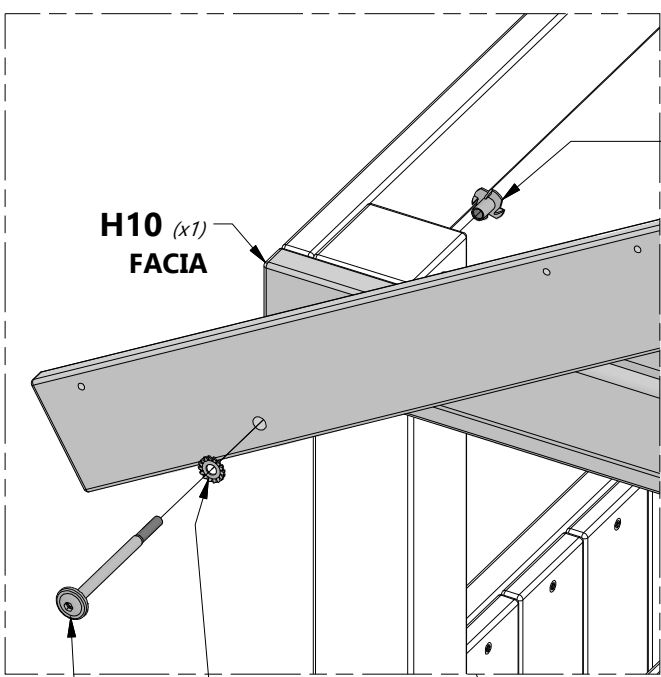
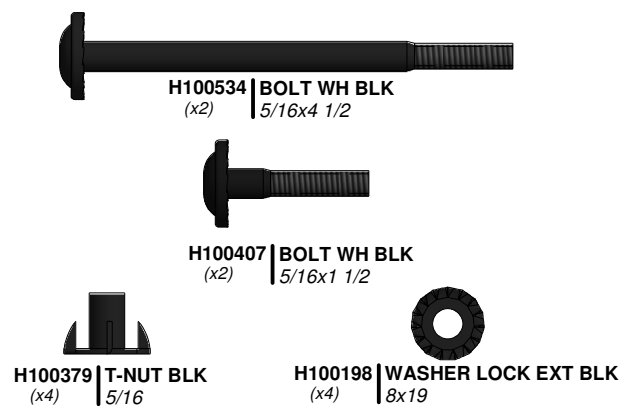
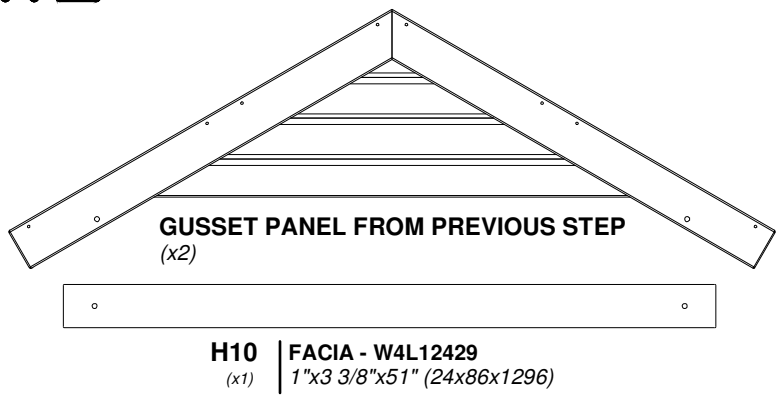

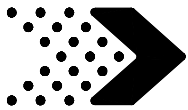

Phase 4

STEP 4

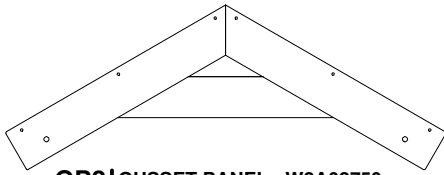

GP2 | GUSSET PANEL - W2A02750
(x2) | 1 1/16"x12 3/4"x34 9/16" (27x326x874)

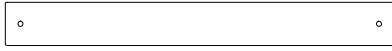

M11 | TOP RAIL BOARD - W4L12434
(x2) | 5/8"x3 3/8"x30 3/8" (16x86x772)

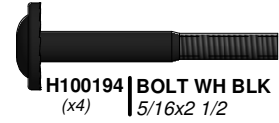

H100194 | BOLT WH BLK
(x4) | 5/16x2 1/2



H100379 | T-NUT BLK
(x4) | 5/16



H100198 | WASHER LOCK EXT BLK
(x4) | 8x19

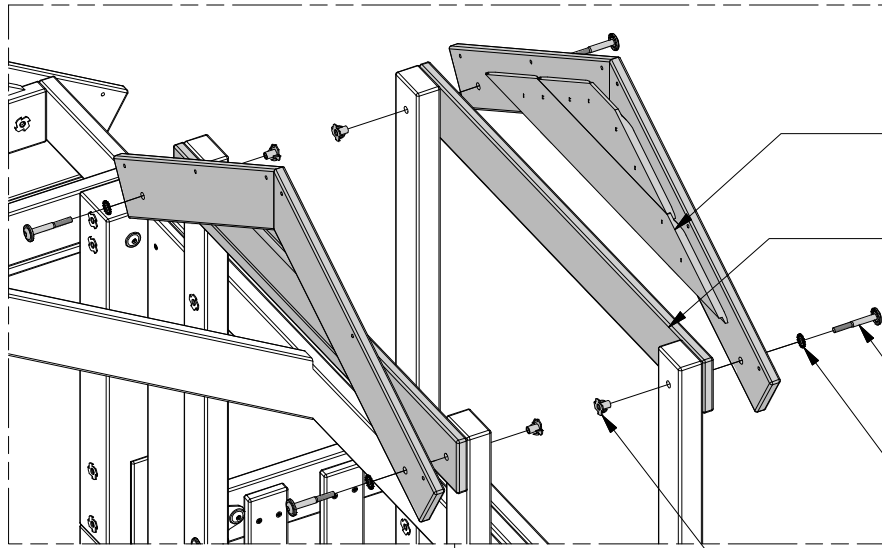

GP2 (x2)
GUSSET PANEL
M11 (x2)
TOP RAIL BOARD

194 (x4)
BOLT - 2 1/2"
198 (x4)
WASHER - 8x19

379 (x4)
T-NUT - 5/16"

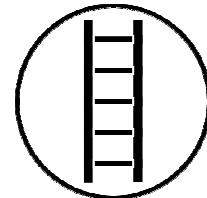
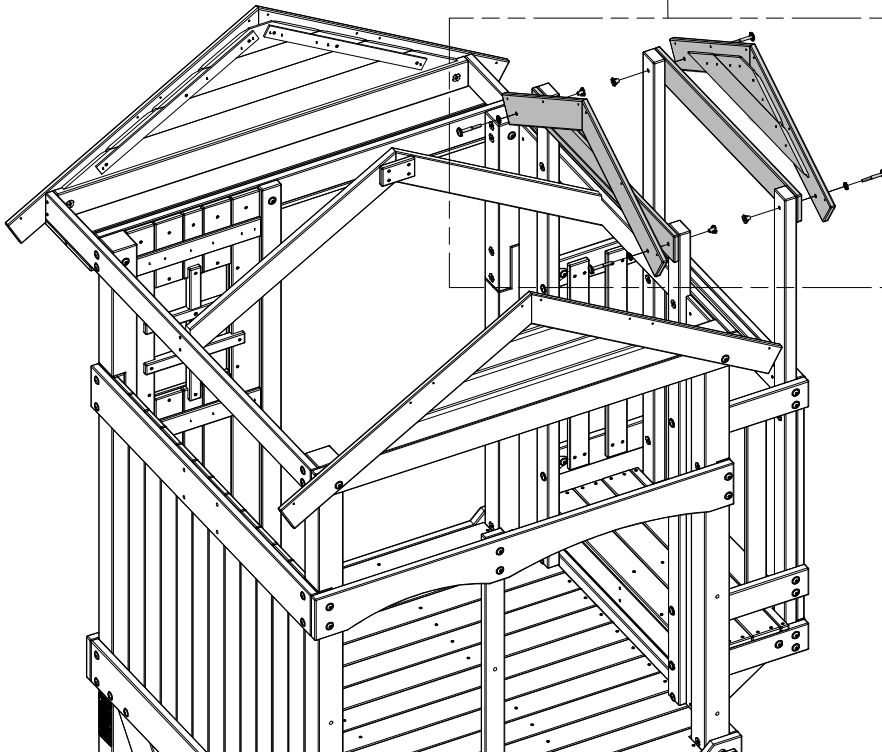

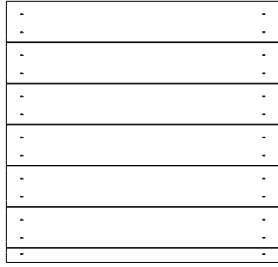
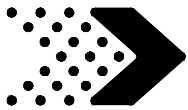

RP4 | ROOF PANEL - W2A02756
(x2) | 1 3/8"x20 3/8"x21 5/16" (35x517x541)



H100200 | SCREW PFH BLK
(x12) | 8x1 1/2

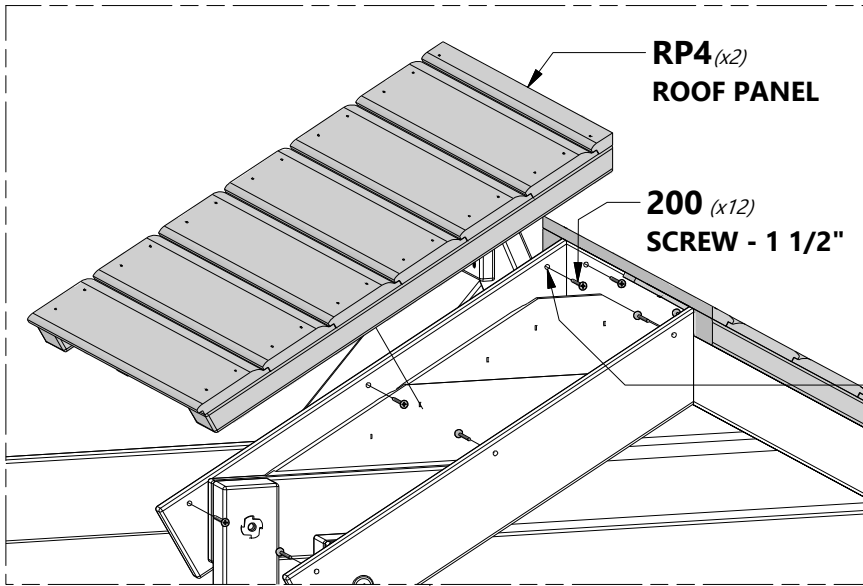

NOTE PILOT HOLES



ASSEMBLY TIP:

USE A HELPER TO HOLD THE PANELS AND TO MAKE SURE THE PANELS ARE CENTERED ON THE PEAK DURING ASSEMBLY.

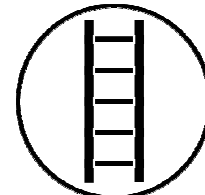
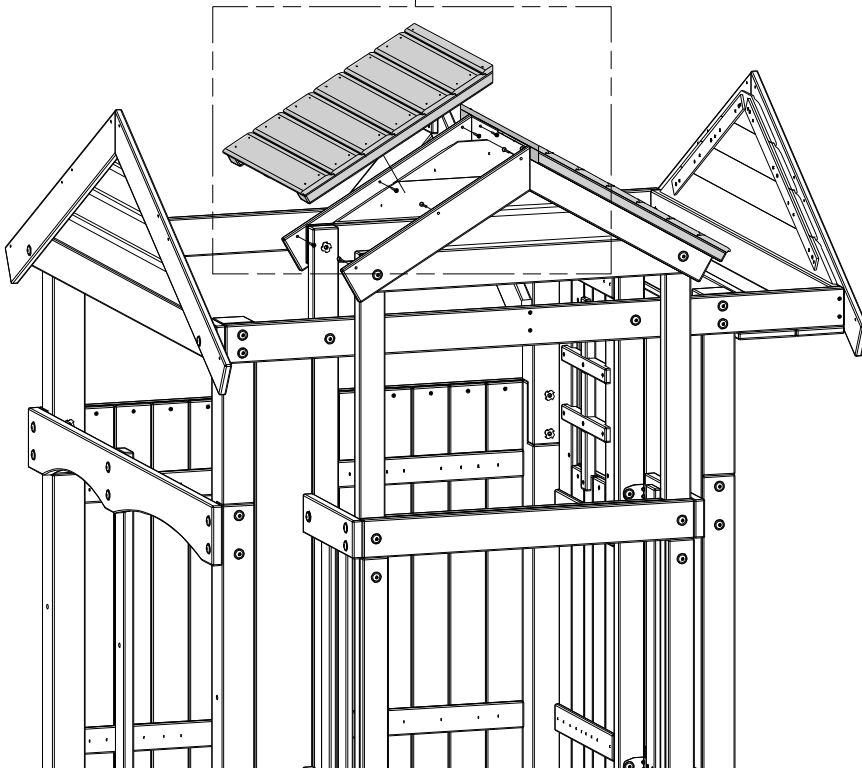

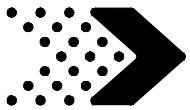

Phase 4

STEP 6

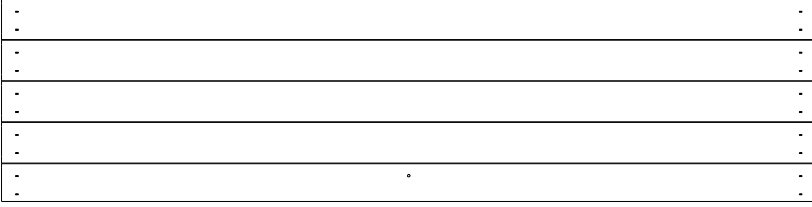

RP1 | ROOF PANEL - W2A02753
(x2) | 1 3/8"x15 13/16"x63 5/8" (35x401x1616)



H100200 | SCREW PFH BLK
(x10) | 8x1 1/2

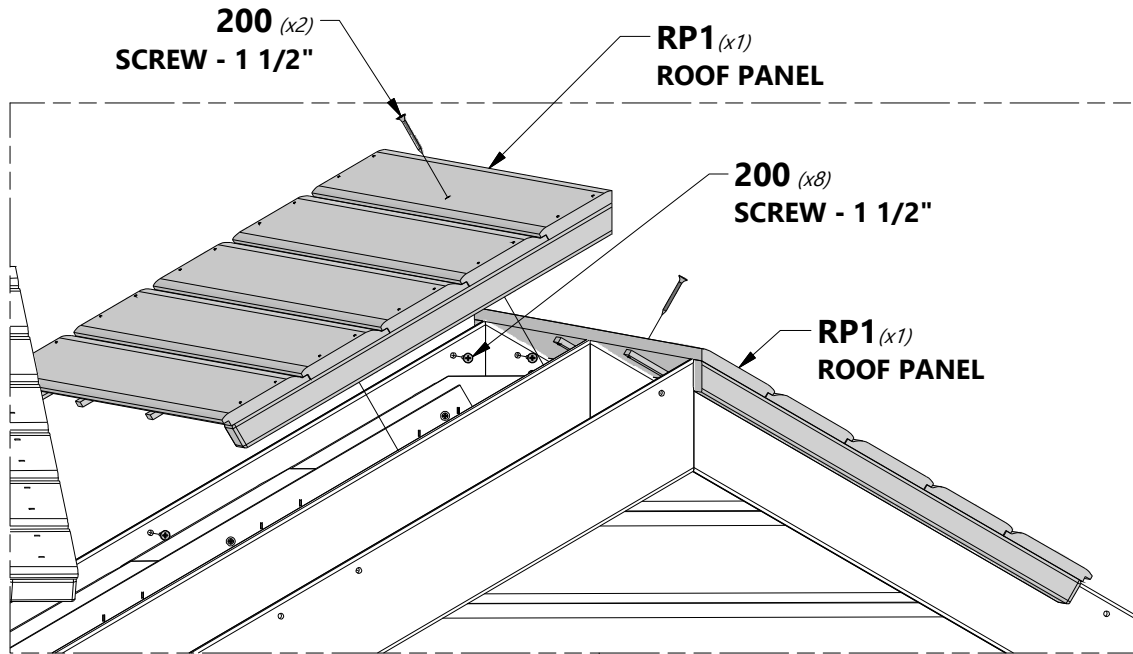

ASSEMBLY TIP:

USE A HELPER TO HOLD THE PANELS AND HELP MAKE SURE THE PANELS ARE CENTERED ON THE PEAK DURING ASSEMBLY.

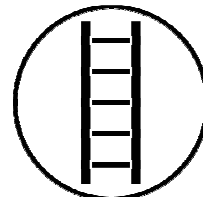
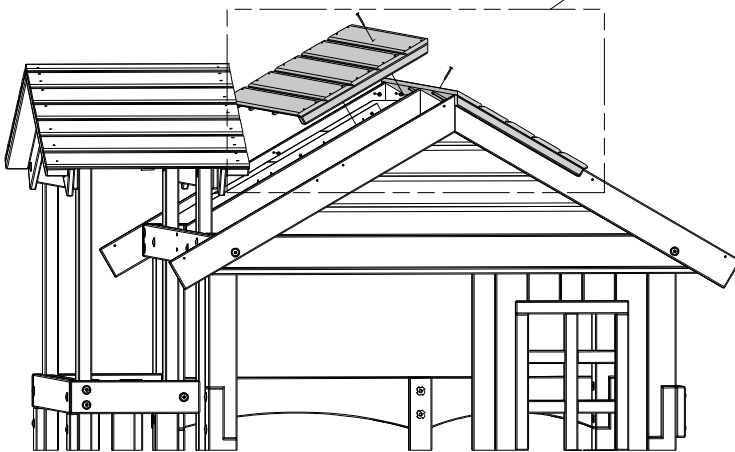

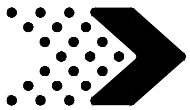

Phase 4

STEP 7

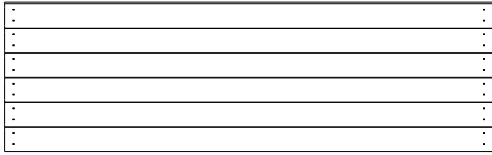

RP2 | ROOF PANEL - W2A02754
(x1) | 1 3/8"x19 7/16"x63 5/8" (35x494x1616)

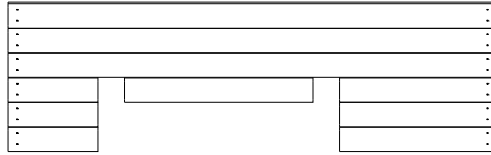

RP3 | ROOF PANEL - W2A02755
(x1) | 1 3/8"x19 7/16"x63 5/8" (35x494x1616)

H100200 | SCREW PFH BLK
(x8) | 8x1 1/2

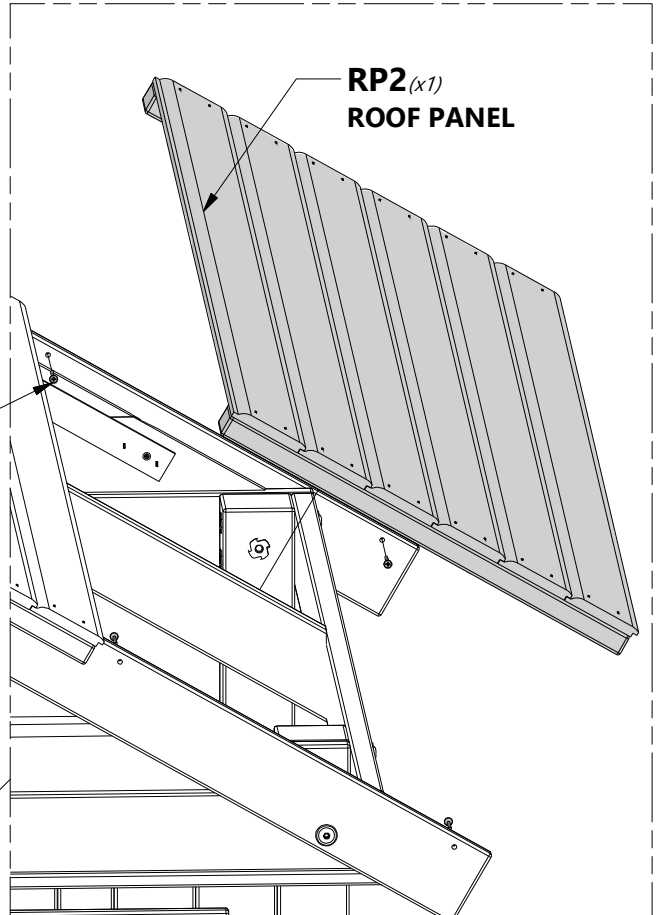
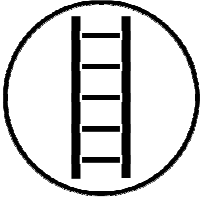

ASSEMBLY TIP:
INSTALL THE RP3 PANEL
USING THE SAME STEPS AS
SHOWN ON THE RP2 PANEL.

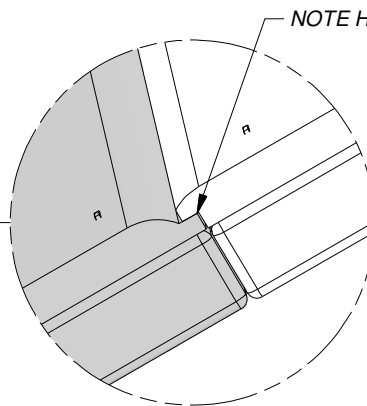
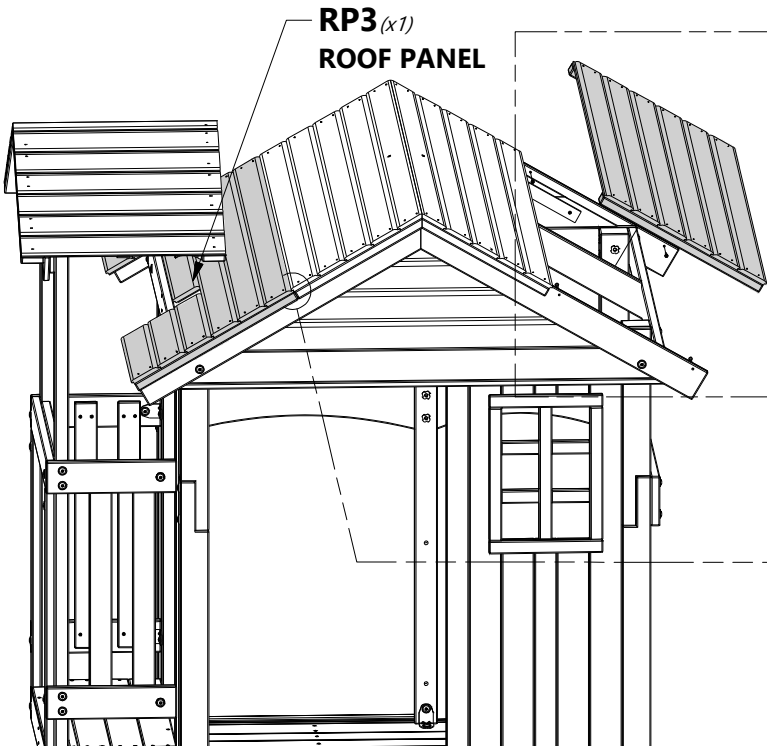

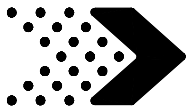

Phase 5

STEP 1



A100118 | **HAND GRIP METAL GREEN 381 c/c**
(x3)



H100416 | **BOLT WH BLK**
(x4) | 5/16x3



H100468 | **BOLT WH BLK**
(x2) | 5/16x1



H100379 | **T-NUT BLK**
(x6) | 5/16

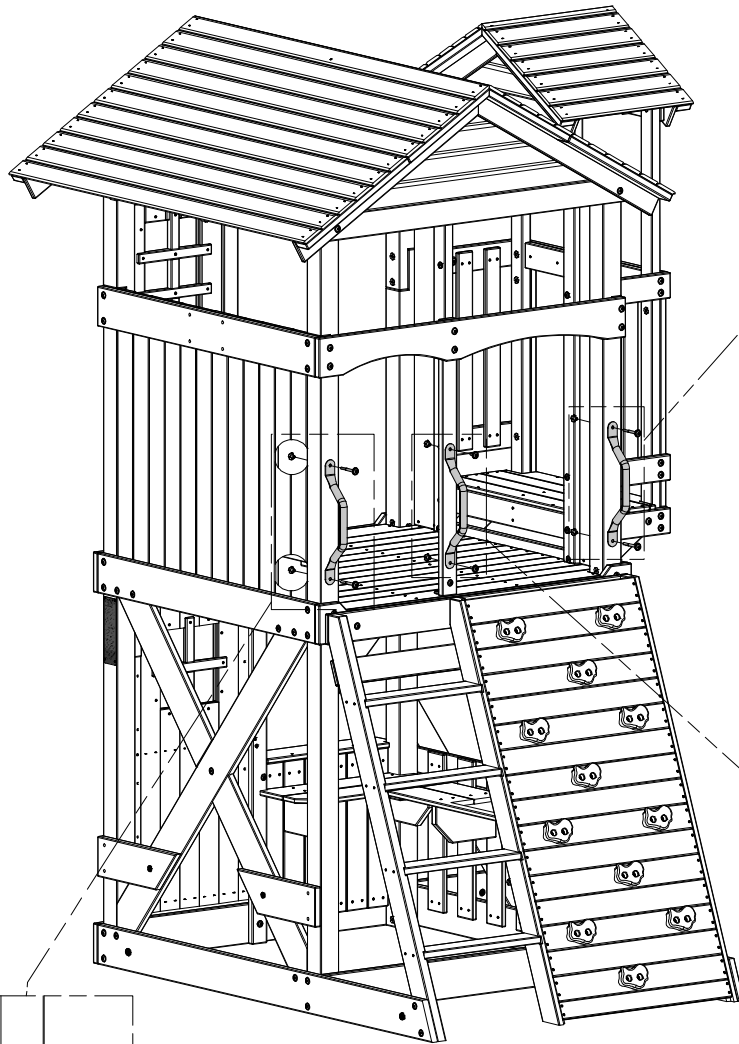

379 (x2)
T-NUT - 5/16"

416 (x2)
BOLT - 3"

379 (x2)
T-NUT - 5/16"

468 (x2)
BOLT - 1"

416 (x2)
BOLT - 3"

379 (x2)
T-NUT - 5/16"

118 (x3)
HAND GRIP METAL GREEN 381 c/c

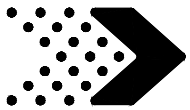

Phase 6

STEP 1

A2 | **SB 9" BLOCK - W4L12441**
 (x1) | 3 3/8"x5 1/4"x9" (86x134x228)



A1 | **SWING BEAM - W4L12440**
 (x1) | 3 3/8"x5 1/4"x89 1/2" (86x134x2274)



A100325 | **SWING BEAM EXTENSION BRACKET-LEFT**
 (x1)



A4M00993 | **EXTENDED SWING BEAM BRACKET**
 (x2)



A100326 | **SWING BEAM EXTENSION BRACKET-RIGHT**
 (x1)



H100416 | **BOLT WH BLK**
 (x10) | 5/16x3



H100192 | **NUT BARREL WH BLK**
 (x10) | 5/16x7/8

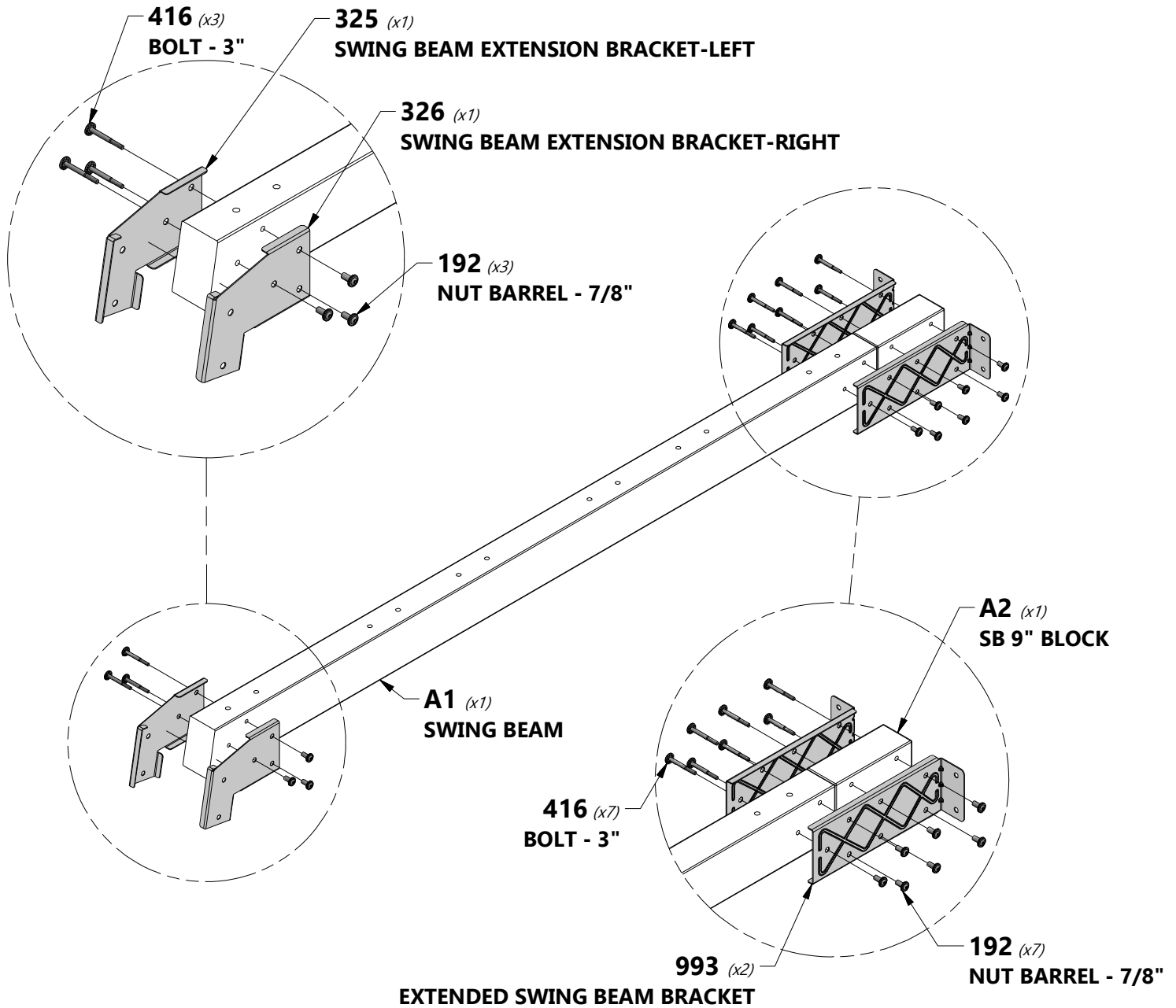

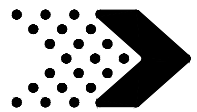

Phase 6

STEP 2

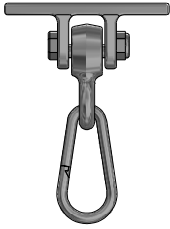

A4M00926 | SINGLE DUCTILE HANGER SD
(6)



H100665 | BOLT HEX SD
(x12) | 3/8x5 3/4

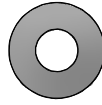

H100703 | WASHER FLAT SD
(x12) | 11x25



H100708 | WASHER LOCK INT SD
(x12) | 10x18

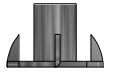

H100700 | T-NUT SD
(x12) | 3/8

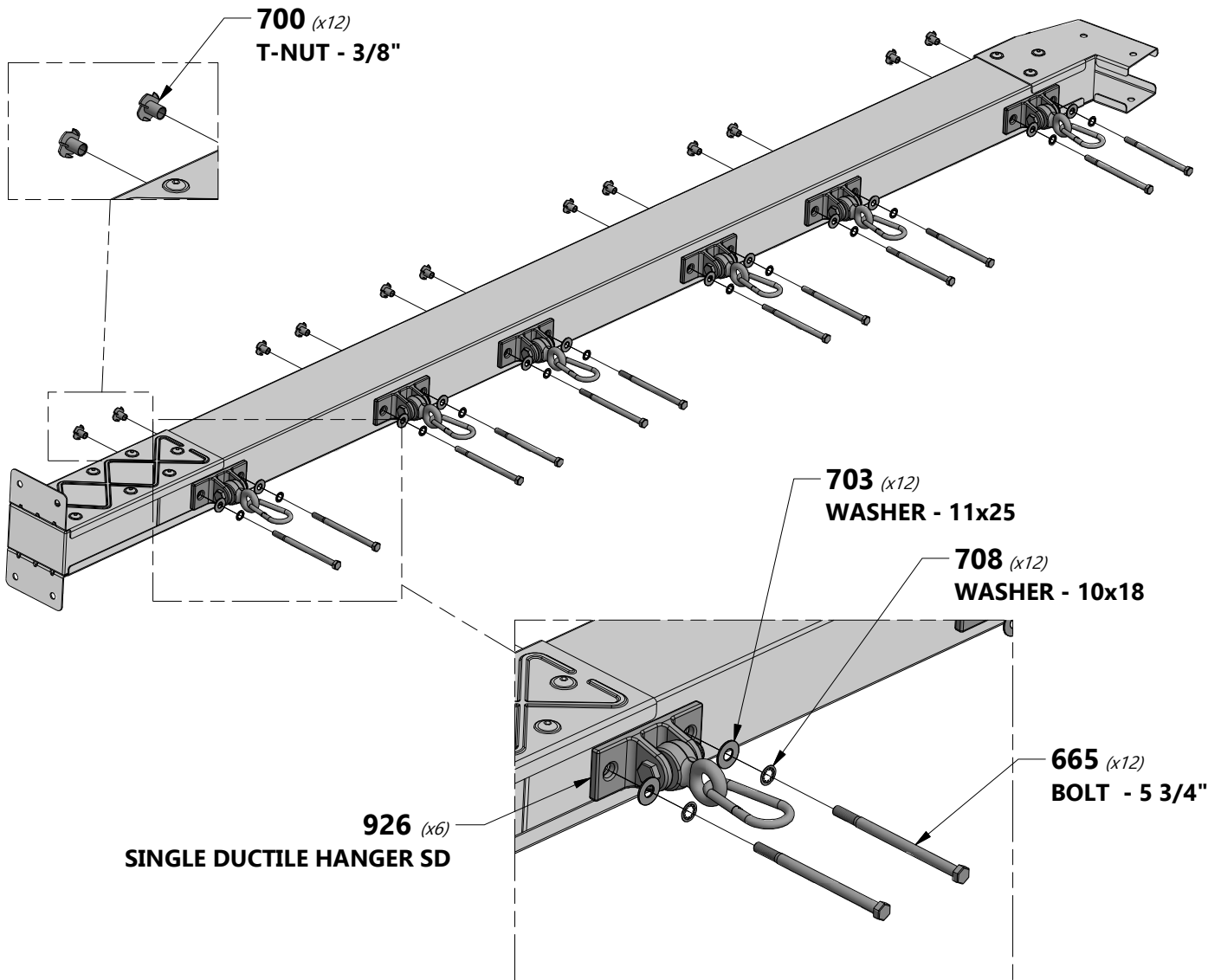



Phase 6

STEP 3

SP1 | SWING BEAM SUPPORT - W4L12439
 (x1) | 3 3/8"x3 3/8"x49 3/8" (86x86x1254)

E4 | S.B. ANGLE BRACE - W4L12444
 (x2) | 1 3/8"x3 3/8"x88 3/4" (36x86x2254)

G16 | GROUND BOARD - W4L12442
 (x1) | 1"x5 1/4"x86 3/4" (24x134x2202)

E5 | S.B. END SUPPORT - W4L12443
 (x1) | 1 3/8"x3 3/8"x44 1/8" (36x86x1120)

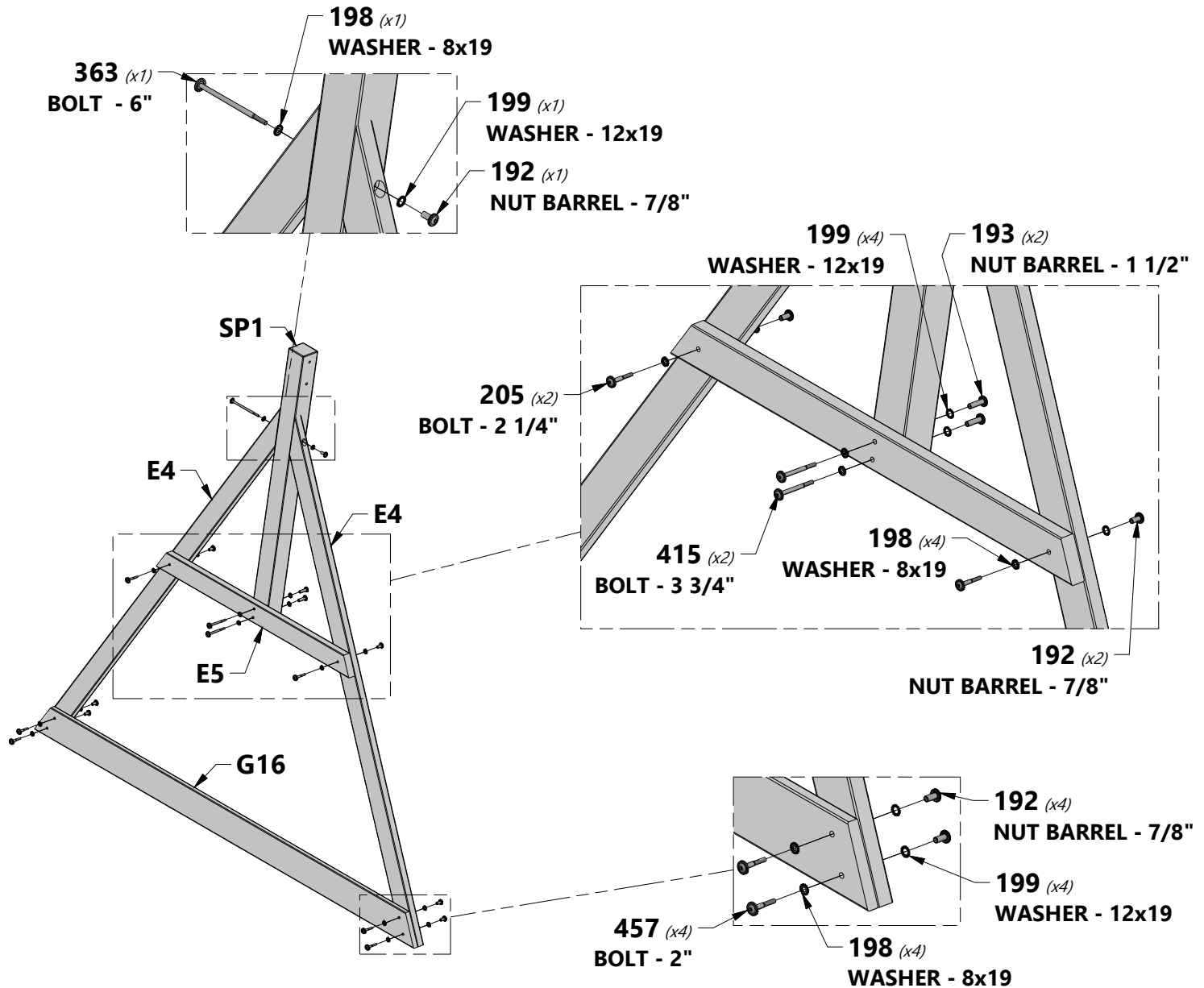
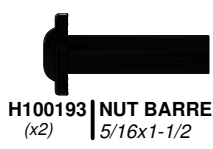
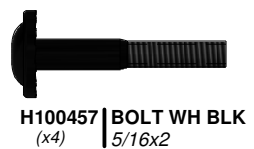
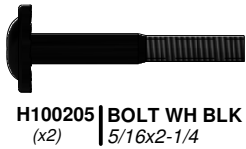
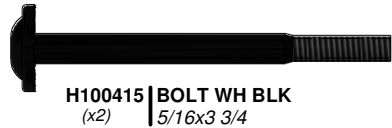
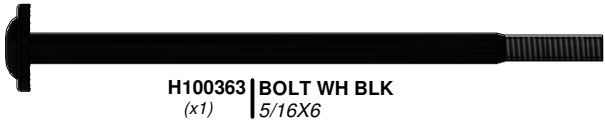



Phase 6

STEP 4



H100416 | BOLT WH BLK
(x2) | 5/16x3



H100192 | NUT BARREL WH BLK
(x2) | 5/16x7/8

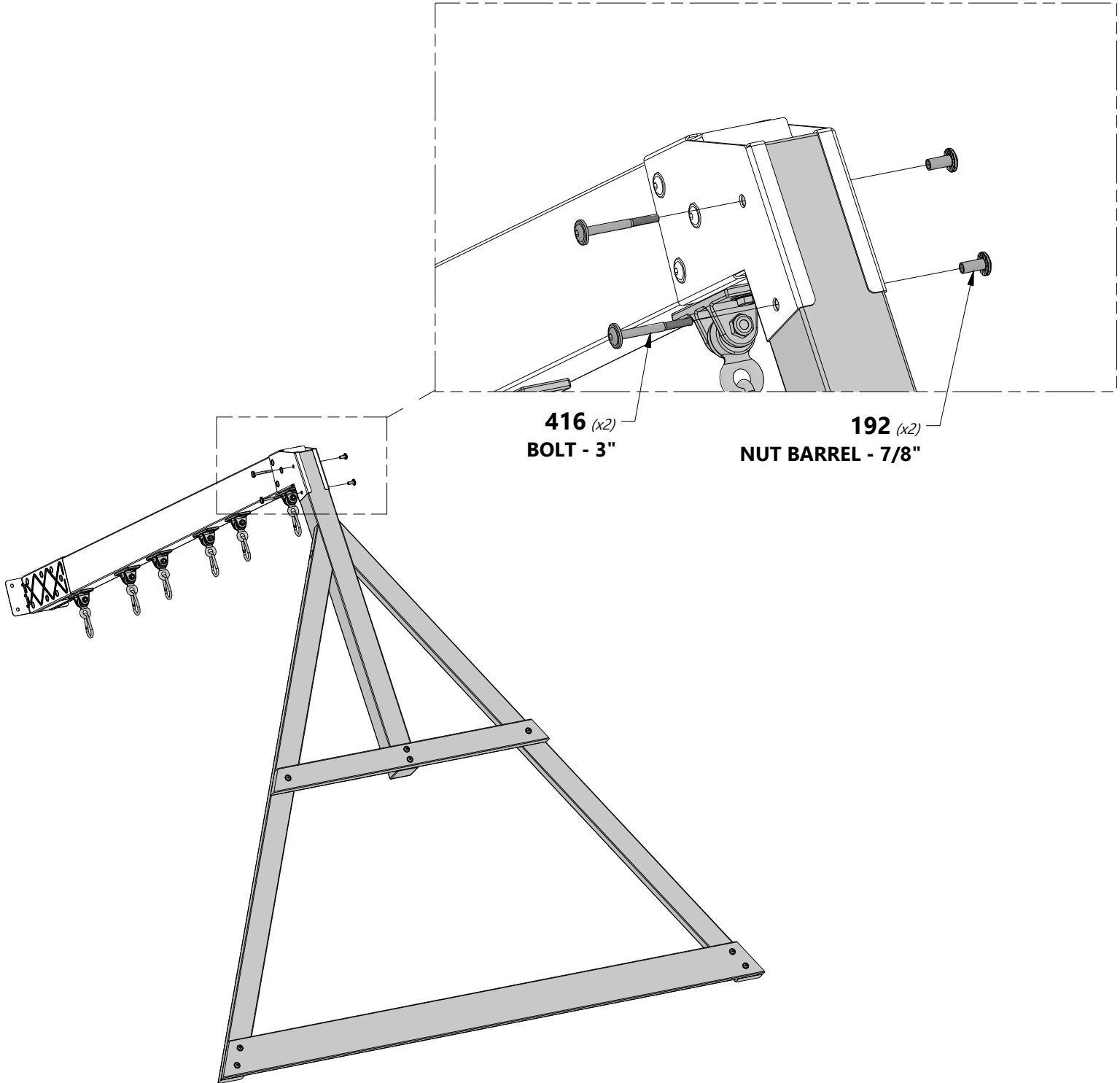

416 (x2)
BOLT - 3"

192 (x2)
NUT BARREL - 7/8"

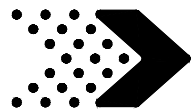

Phase 6

STEP 5

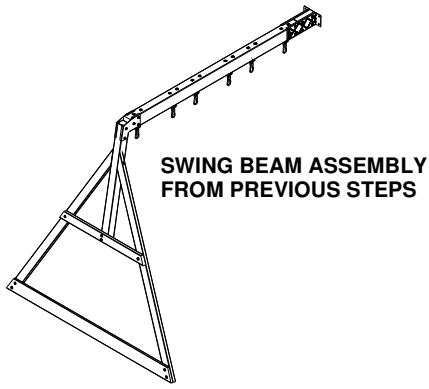

H100481 | BOLT HEX BLK
(x4) | 5/16x1 1/4

H100478 | WASHER FLAT BLK
(x4) | 8x27

H100477 | WASHER SPLIT BLK
(x4) | 5/16



ASSEMBLY NOTE:
INSTALL HARDWARE USING
THE T-NUTS THAT WERE
PREVIOUSLY INSTALLED.

478 (x4)
WASHER - 8x27

477 (x4)
WASHER - 5/16

481 (x4)
BOLT - 1 1/4"

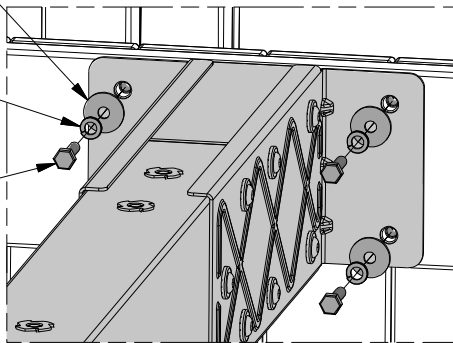

SWING BEAM ASSEMBLY

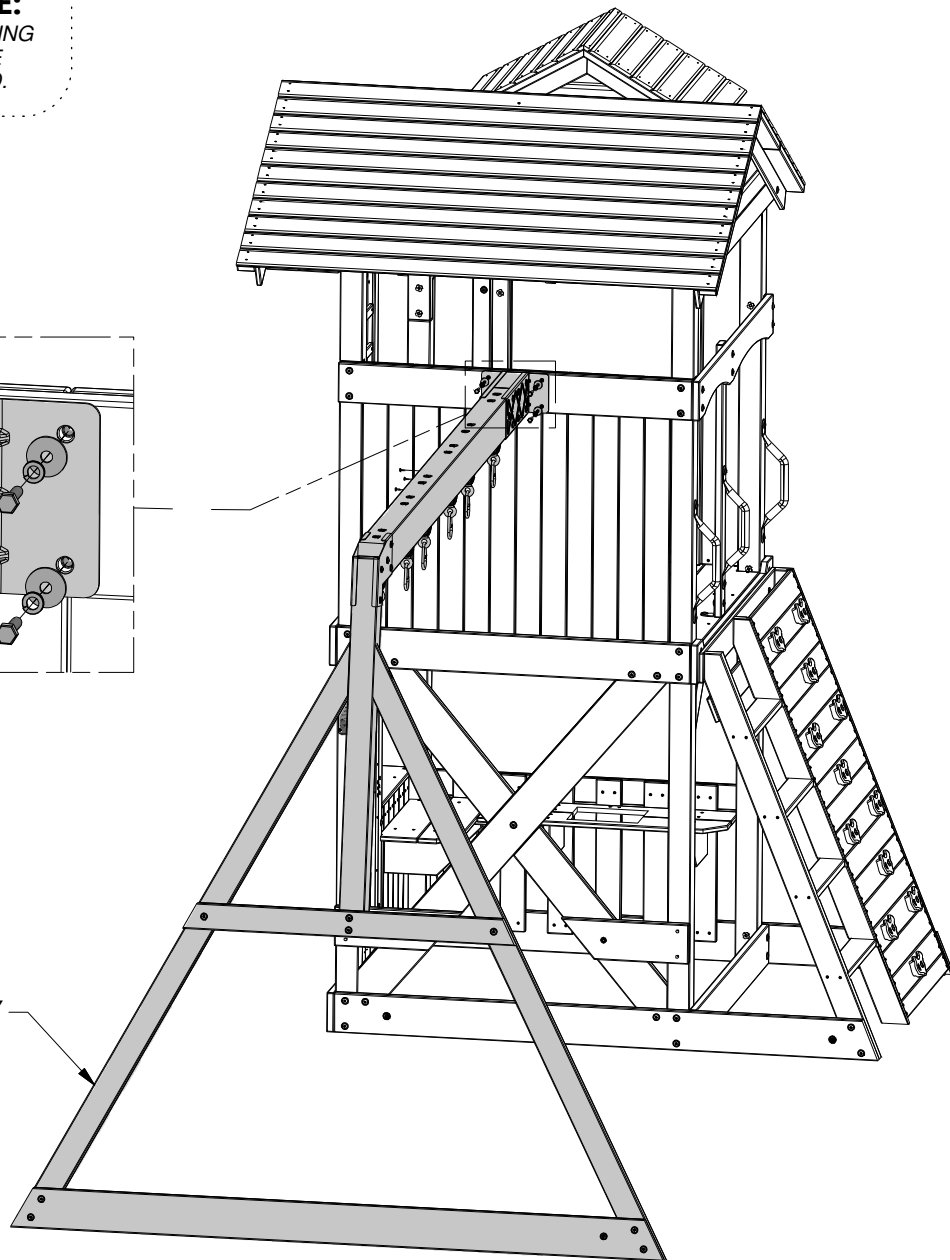

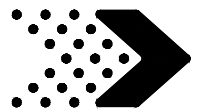

Phase 6

STEP 6

A4M00927
(x4) **QUICK LINK SD**

A100164
(x1) **BYD ID TAG (LARGE) AGES 3-10**

A4M01005
(x4) **CHAIN GREEN 7mm x 1452mm (57in)**

A6P00362
(x2) **26" HD BELT SWING**



A4M01126
(x1) **26" WEB SWING**

H100202
(x4) **SCREW PWH BLK 8x5/8**

164 (x1)
BYD ID TAG (LARGE) AGES 3-10

202 (x4)
SCREW - 5/8"

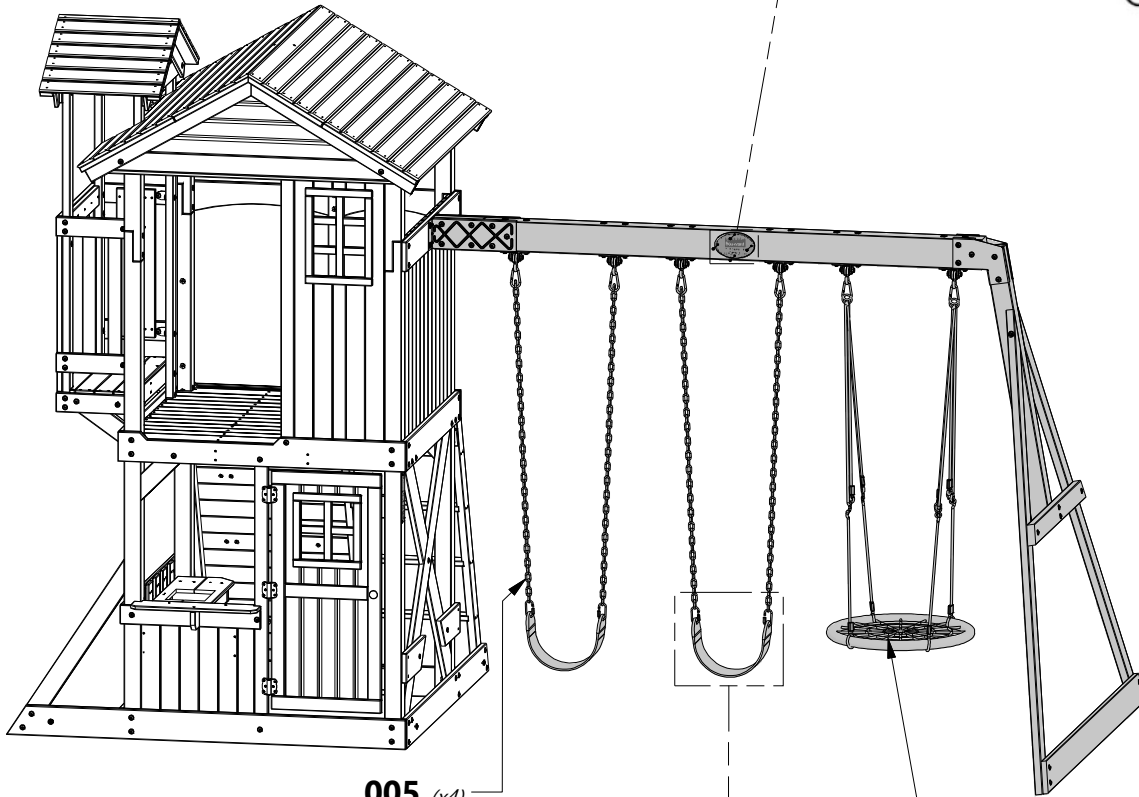
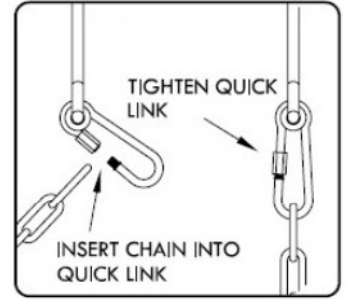

005 (x4)
CHAIN GREEN 7mm x 1452mm (57in)

126 (x1)
26" WEB SWING

927 (x4)
QUICK LINK SD

362 (x2)
26" HD BELT SWING

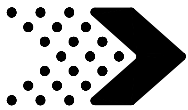

SETUP

WEB SWING

WEB SWING SETUP INSTRUCTIONS:

FOLLOW INSTRUCTIONS BELOW BEFORE USING THE WEB SWING.



H100832 | BOLT PTH
(4) | 1/4x3/4



H100831 | NUT BARREL PTH BLK
(4) | 1/4x3/4



IMPORTANT:
SLIDE ROPE LOOPS OVER TUBE ENDS FIRST!

SLIDE NARROW END OF TUBES INTO LARGER OPENING AFTER SLIDING ROPE LOOPS ONTO TUBES.

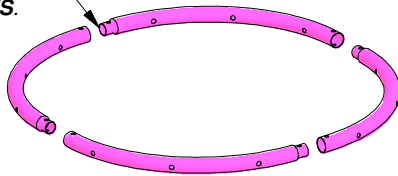

NOTE: ROPE WEBBING NOT SHOWN IN ILLUSTRATION FOR CLARITY.

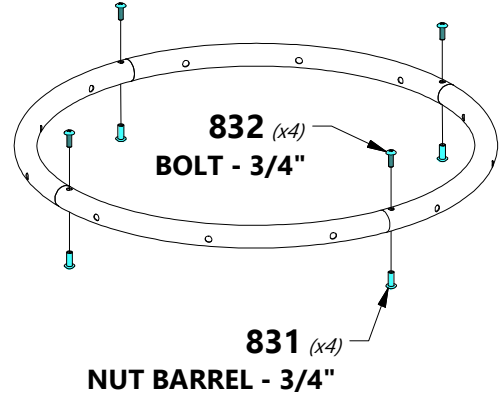

Note: It is important that the web swing hang level.



IMPORTANT

TO ENSURE STRAIGHT SWINGING MOTION, ADJUST BOTH "S" BRACKETS UNTIL WEB SEAT IS LEVEL.



IMPORTANT:

SWING MUST BE SET AT A MINIMUM OF 8 INCHES OFF THE GROUND WHEN INSTALLED.

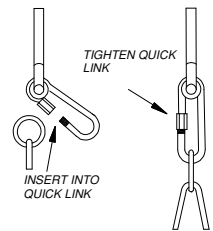
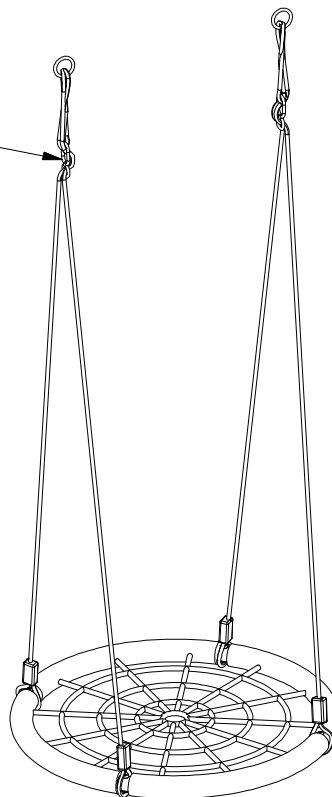

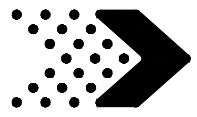

Phase 7

STEP 1

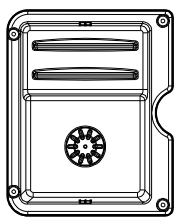

A6P00332 | PREMIUM SINK
(x1)

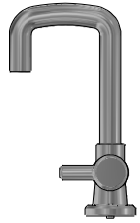

A6P00333 | FAUCET
(x1)



H100202 | SCREW PWH BLK
(x4) | 8x5/8



H100385 | SCREW PFH BLK
(x2) | 8x1

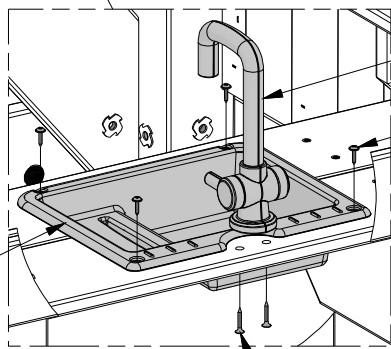
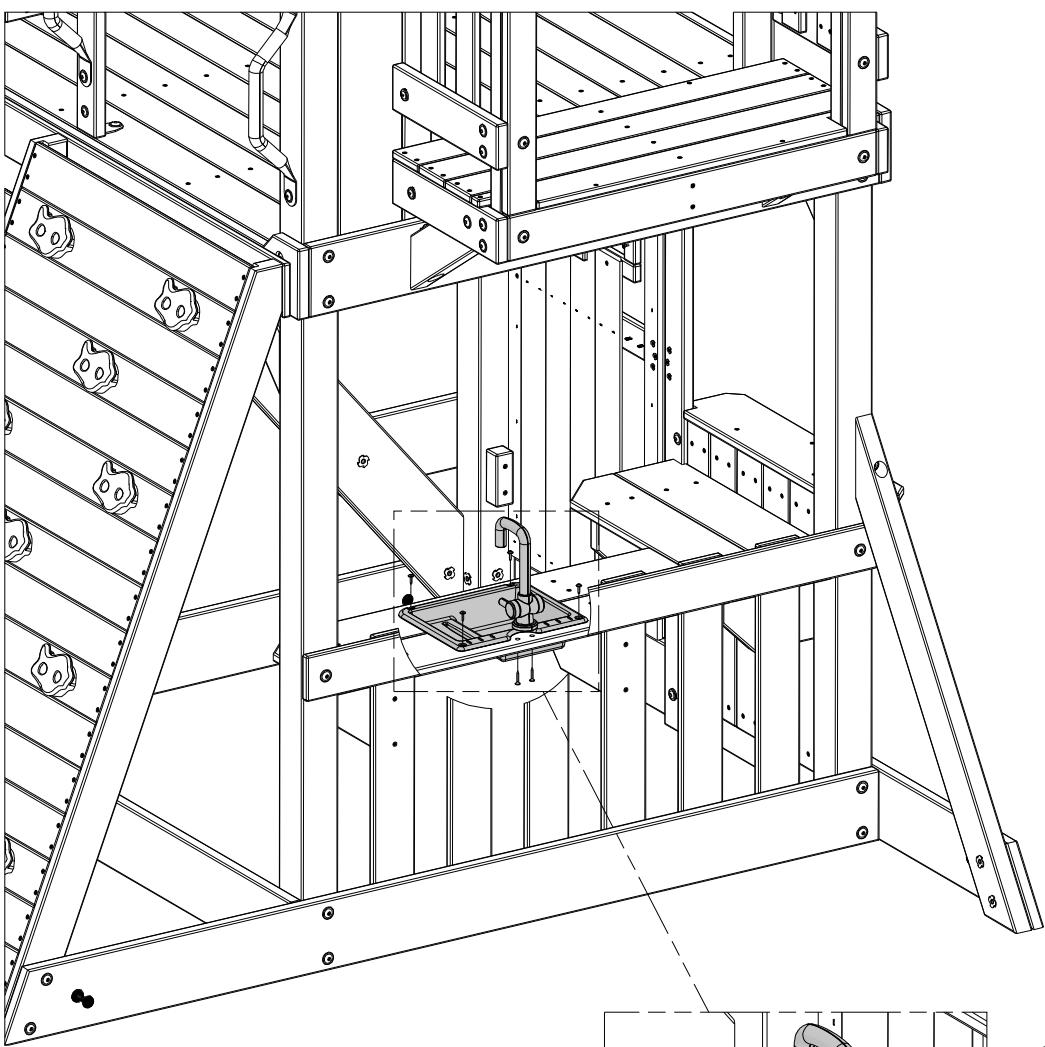

332 (x1)
PREMIUM SINK

333 (x1)
FAUCET

202 (x4)
SCREW - 5/8"

385 (x2)
SCREW - 1"

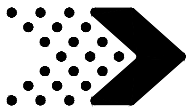

CLASS B DIGITAL DEVICE STATEMENT

Note:

This equipment has been tested and found to comply with the limits for a Class B digital device, pursuant to part 15 of the FCC Rules. These limits are designed to provide reasonable protection against harmful interference in a residential installation. This equipment generates, uses and can radiate radio frequency energy and, if not installed and used in accordance with the instructions, may cause harmful interference to radio communications. However, there is no guarantee that interference will not occur in a particular installation. If this equipment does cause harmful interference to radio or television reception, which can be determined by turning the equipment off and on, the user is encouraged to try to correct the interference by one or more of the following measures:

- Reorient or relocate the receiving antenna.
- Increase the separation between the equipment and receiver.
- Connect the equipment into an outlet on a circuit different from that to which the receiver is connected.
- Consult the dealer or an experienced radio/TV technician for help

Caution: Changes or modifications not expressly approved by the party responsible for compliance could void the user's authority to operate the equipment.

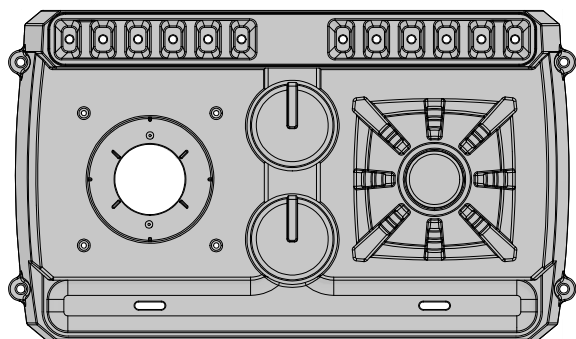

A6P00335 | STOVE BASE
(x1)



A6P00330 | INDUCTIVE BURNER KIT
(1)

ROTATE TO REMOVE COVER

"AA" BATTERY (x3)
(Not Included)

330 (x1)
INDUCTIVE BURNER KIT

ASSEMBLY NOTE:

ALWAYS WASH TOYS BEFORE USE.

- REMOVE THE FIRST COVER BY TWISTING IT COUNTER CLOCKWISE. REMOVE THE BATTERY COVER AND INSTALL THE BATTERIES (NOT INCLUDED). PUT THE BATTERY COVER BACK ON AND CONTINUE TO THE NEXT DIAGRAM.
- DO NOT MIX OLD AND NEW BATTERIES
- DO NOT MIX ALKALINE, STANDARD (CARBON-ZINC), OR RECHARGEABLE (NI-CAD, NI-MH, ECT.) BATTERIES.

335 (x1)
STOVE BASE

#4 X 5/8" SCREWS INCLUDED WITH THE STOVE KIT.

ASSEMBLY NOTE:

FIRST INSTALL THE COVER YOU REMOVED ABOVE WITH THE INCLUDED HARDWARE. INSTALL THE BURNER BY TWISTING IT CLOCKWISE TO LOCK IT IN PLACE.

FCC LABEL

NOTE: THIS DEVICE COMPLIES WITH PART 15 OF THE FCC RULES. OPERATION IS SUBJECT TO THE FOLLOWING TWO CONDITIONS: (1) THIS DEVICE MAY NOT CAUSE HARMFUL INTERFERENCE (2) THIS DEVICE MUST ACCEPT ANY INTERFERENCE RECEIVED, INCLUDING INTERFERENCE THAT MAY CAUSE UNDESIRED OPERATION.

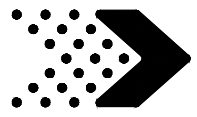

Phase 7

STEP 3

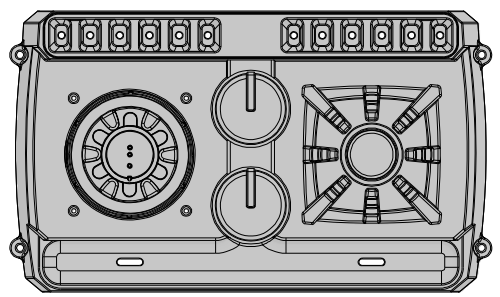

STOVE ASSEMBLY
FROM PREVIOUS STEP



H100202 | SCREW PWH BLK
(x4) | 8x5/8

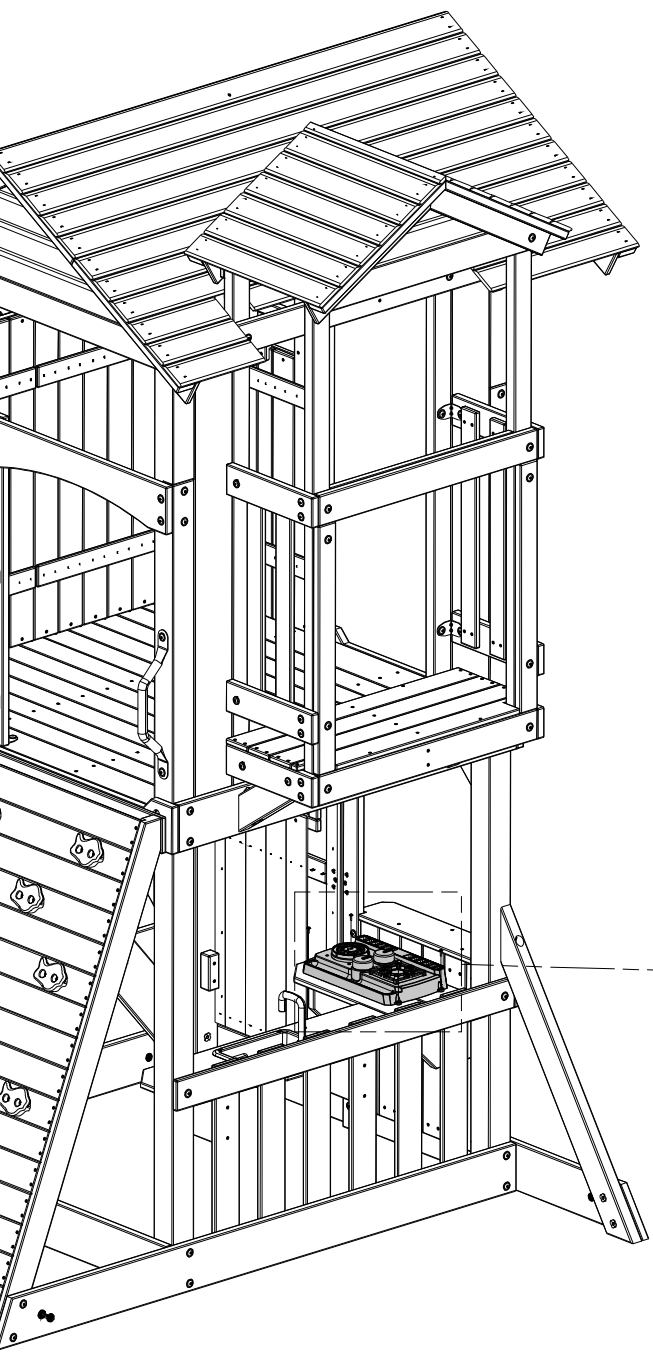

202 (x4)
SCREW - 5/8"

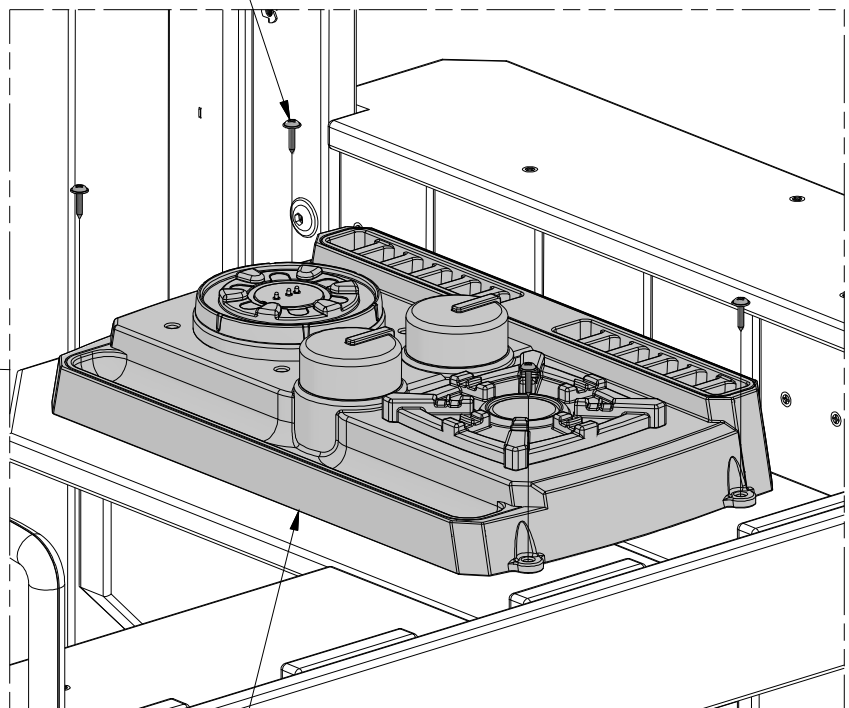

STOVE ASSEMBLY

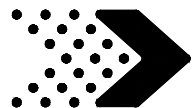

Phase 8

STEP 1

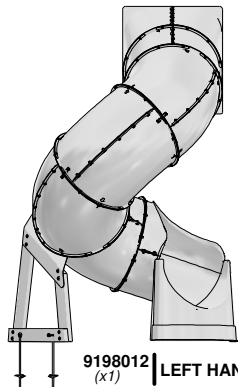

9198012 (x1) LEFT HAND SLIDE



H100797 (x18) SCREW PWH BLK 8x1

NOTE: FOR ASSEMBLY OF THE TUBE SLIDE, PLEASE REFER TO THE LEFT EXIT TUBE SLIDE ASSEMBLY MANUAL FOUND IN THE TUBE SLIDE BOX.

ASSEMBLY TIP: PLACE THE SLIDE ALL THE WAY INSIDE THE OPENING AS SHOWN. MAKE SURE TO PRESS THE SLIDE IN EVENLY AS YOU INSTALL IT WITH THE PROVIDED HARDWARE.

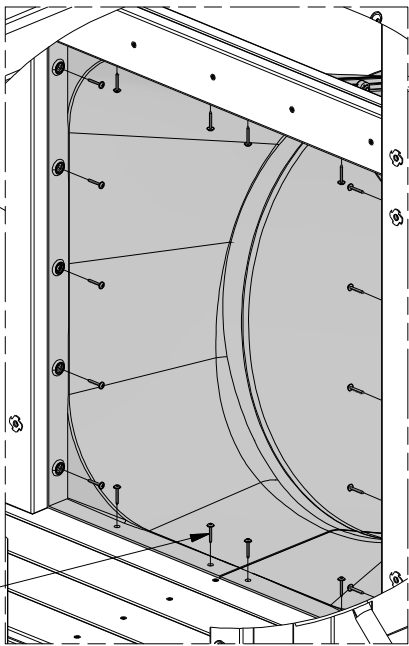
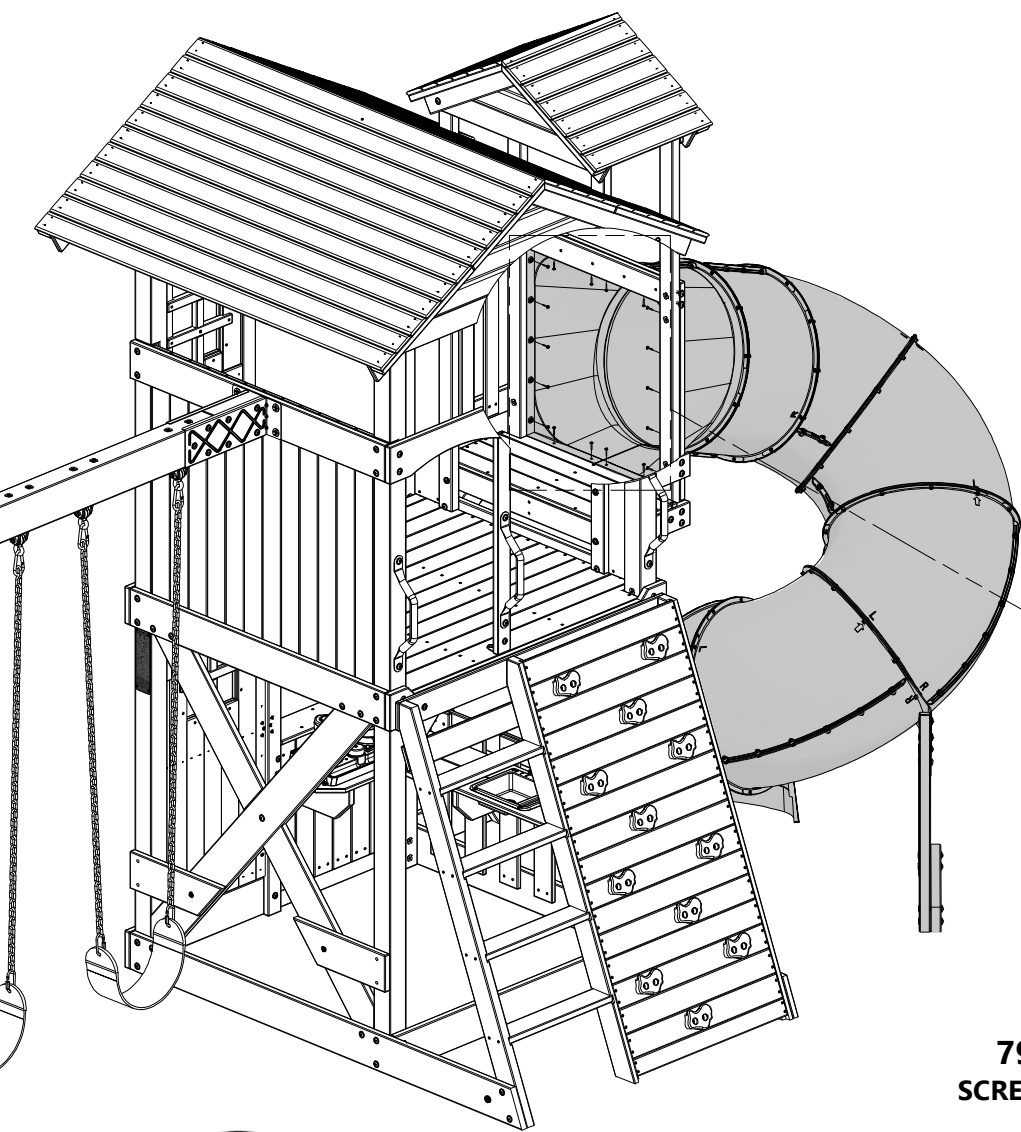

797 (x18) SCREW - 1"



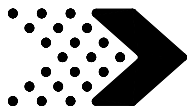

Phase 9

STEP 1



A100287 | SLIDE VF 10 FT
(x1)



O70 | SLIDE MOUNTING BOARD - W4L09040
(x1) | 5/8"x1 3/8"x20 3/8" (16x34x517)

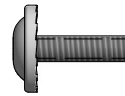

H100008 | BOLT WH
(x3) | 5/16x1



H100031 | WASHER LOCK EXT
(x3) | 12x19



H100004 | NUT BARREL WH
(x3) | 5/16 x 5/8



H100088 | SCREW PFH
(x4) | 8x1 1/8



ATTACH 'O70' BOARD FIRST

4 7/16 in
[113 mm]

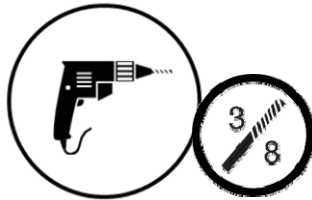
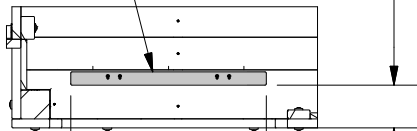

7 7/8 in
[200 mm]

7 7/8 in
[200 mm]

4 1/2 in
[115 mm]

4 1/2 in
[115 mm]

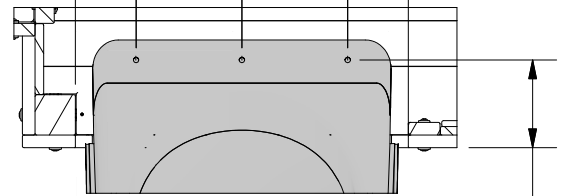

6 1/2 in
[166 mm]



ASSEMBLY NOTE:

1. INSTALL 'O70' BOARD FIRST. NO DRILLING REQUIRED TO ATTACH 'O70' BOARD.

2. USING DIMENSIONS SHOWN DRILL (3) 3/8" (10mm) HOLES THROUGH THE FLOOR. ATTACHED SLIDE USING SUPPLIED HARDWARE.

008 (x4)
BOLT - 5/16x1"

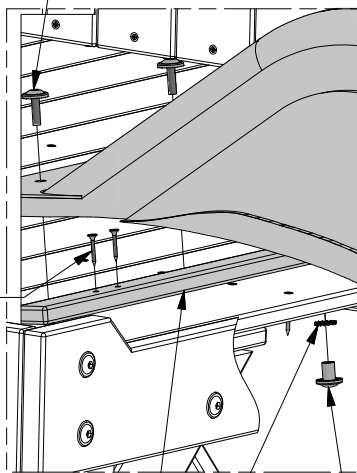

088 (x4)
SCREW - 1 1/8"

O70 (x1)
SLIDE MOUNTING BOARD

031 (x3)
WASHER - 12x19

004 (x3)
NUT BARREL - 5/8"

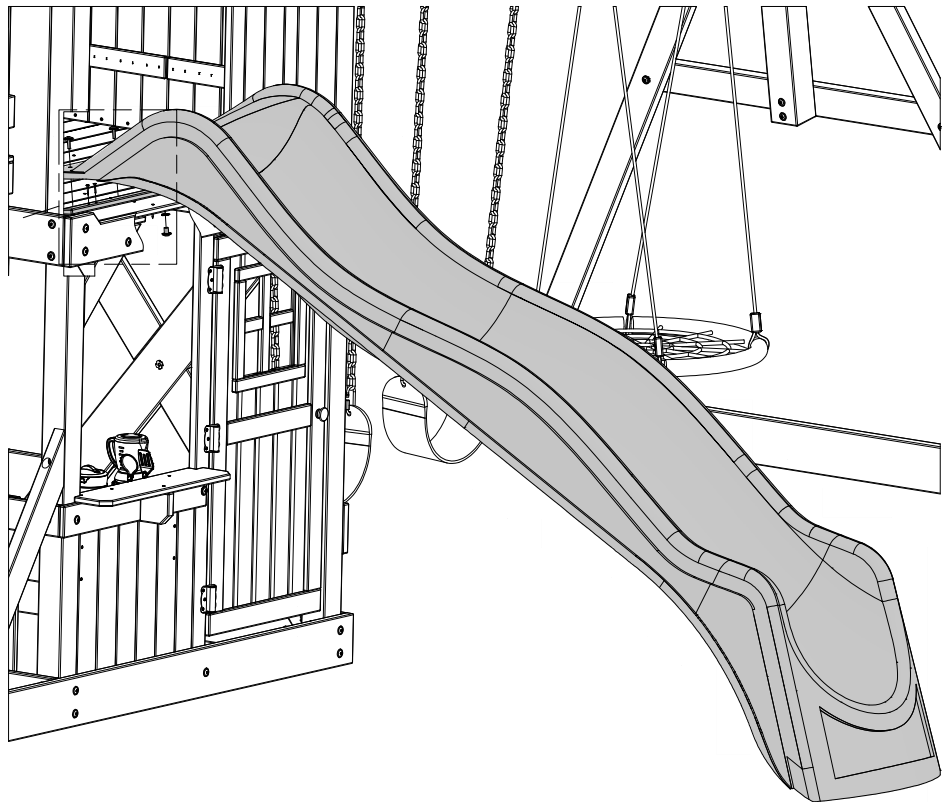

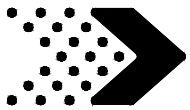

Phase 9

STEP 2

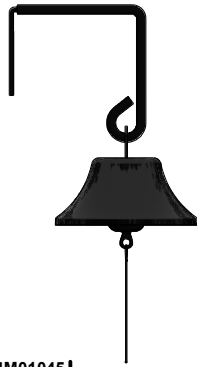

A4M01045 (x1) BELL ASSEMBLY



H100202 SCREW PWH BLK (x2) 8x5/8



ASSEMBLY NOTE:

CENTER THE BELL ASSEMBLY ON THE POST AS SHOWN AND SET TO YOUR DESIRED HEIGHT.

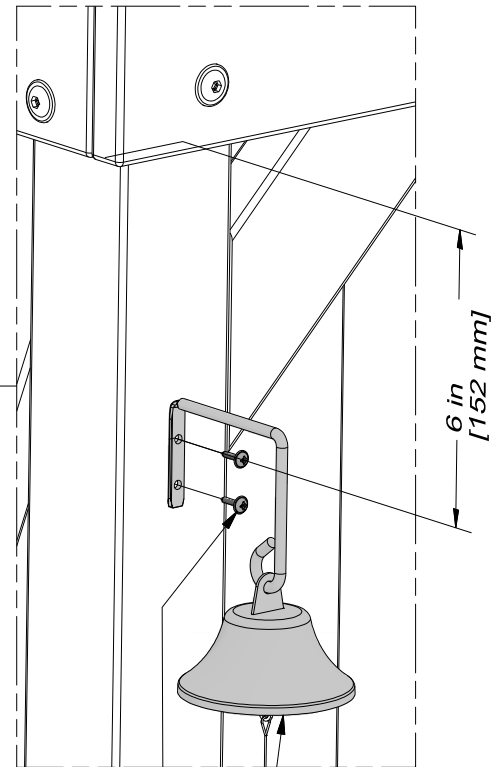
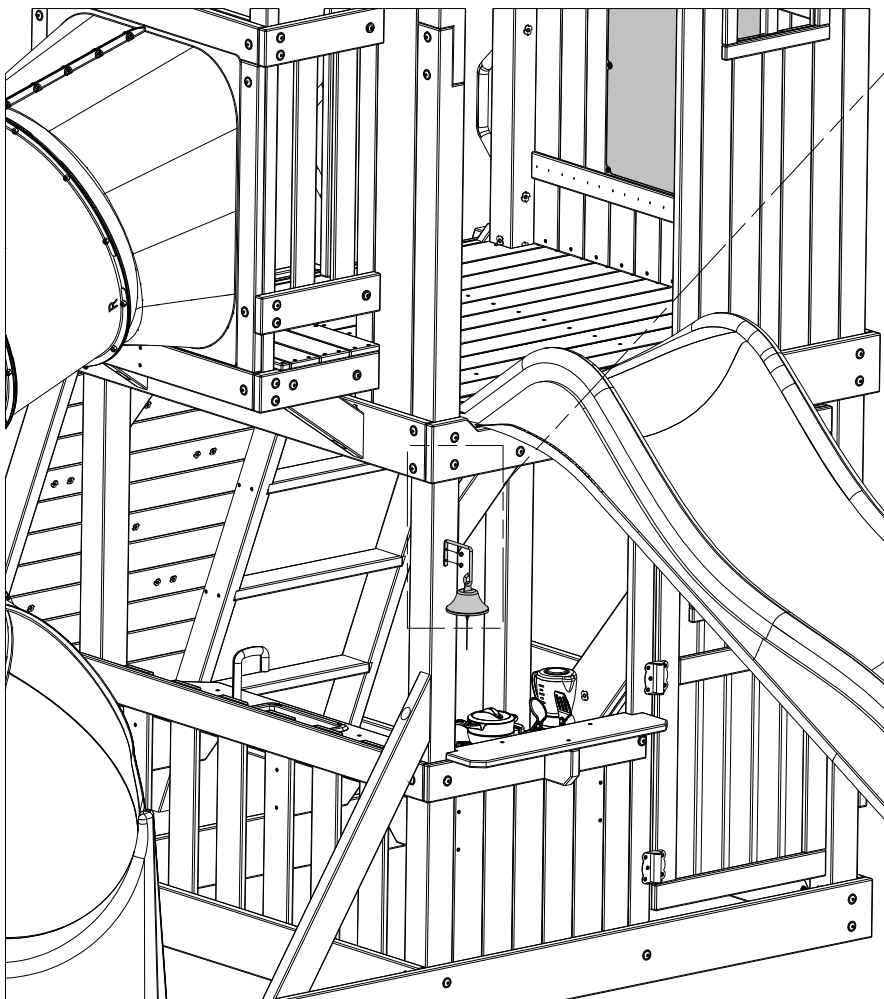

202 (x2) SCREW - 5/8"

045 (x1) BELL ASSEMBLY

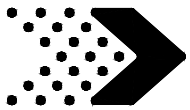

Phase 9

STEP 3



A6P00324 | CHALK BOARD LARGE
(x1)



H100202 | SCREW PWH BLK
(x8) | 8x5/8



ASSEMBLY TIP:

CENTER THE CHALK BOARD VERTICALLY AND HORIZONTALLY BETWEEN THE TWO WALL PANELS WHERE DESIRED AND MOUNT USING THE PROVIDED HARDWARE.

202 (x8)
SCREW - 5/8"

324 (x1)
CHALK BOARD LARGE

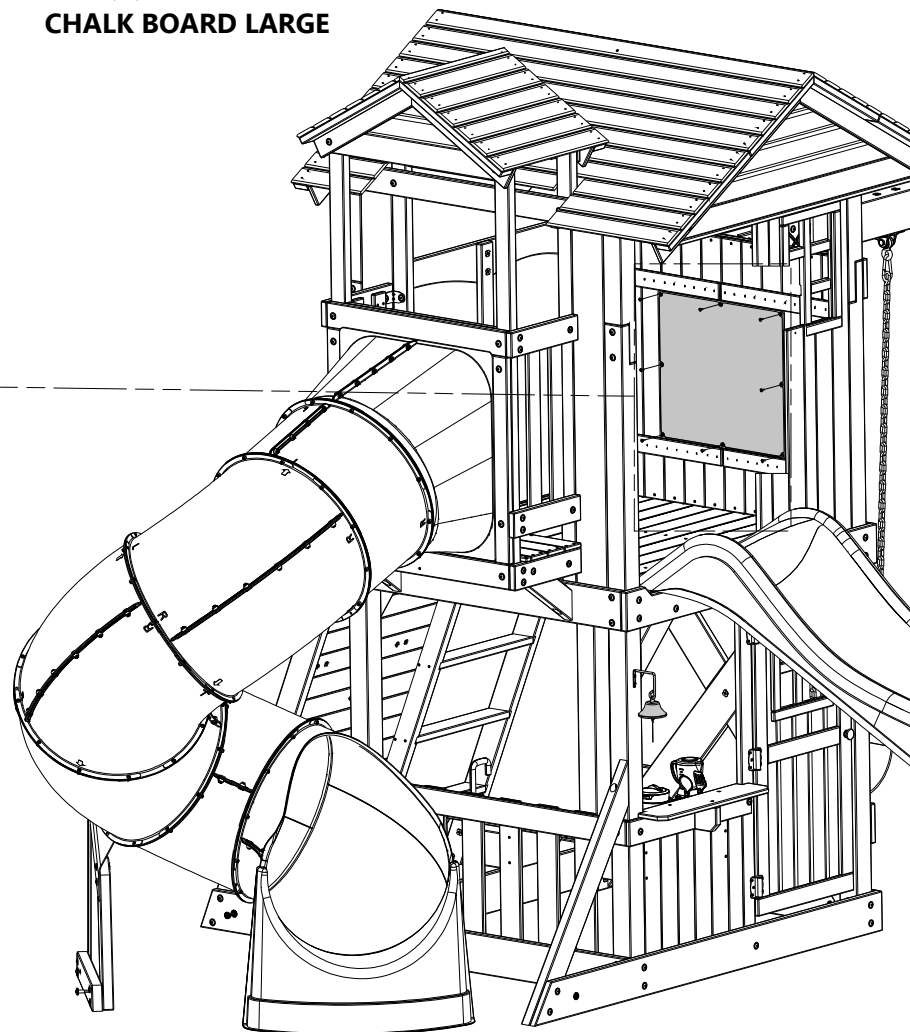
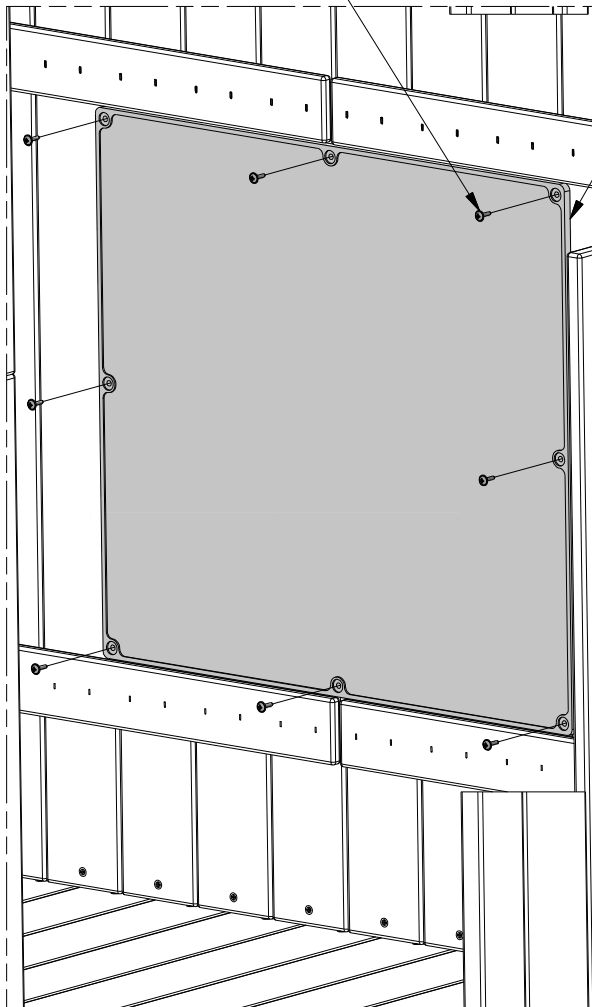

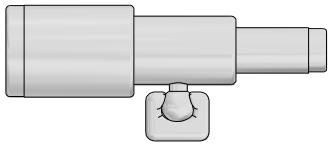
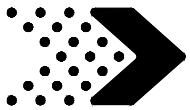

A6P00096 | TELESCOPE
(x1)



H100200 | SCREW PFH BLK
(x2) | 8x1 1/2

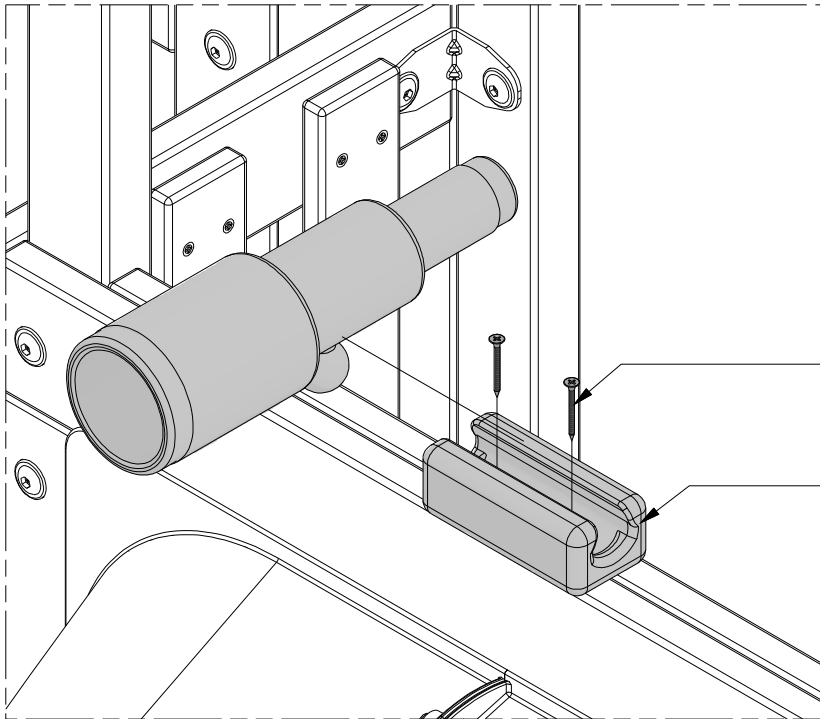

200 (x2)
SCREW - 1 1/2"

096 (x1)
TELESCOPE

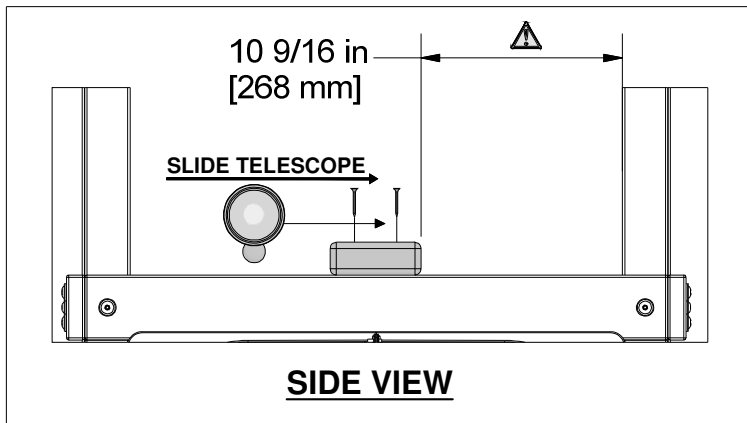
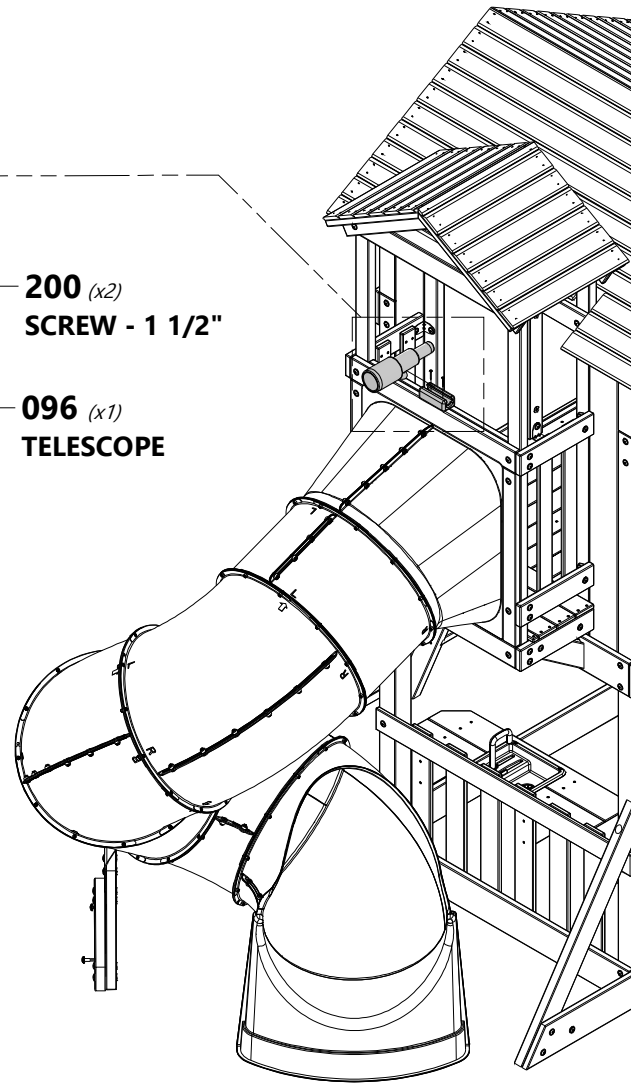

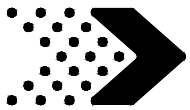

WARNING

FAILURE TO USE GROUND STAKES CAN VOID WARRANTY & CAUSE INJURY!



ASSEMBLY TIP:

USE THIS PAGE TO GET FAMILIAR WITH THE LOCATIONS OF EACH GROUND STAKE BEFORE MOVING ON TO THE NEXT STEP.

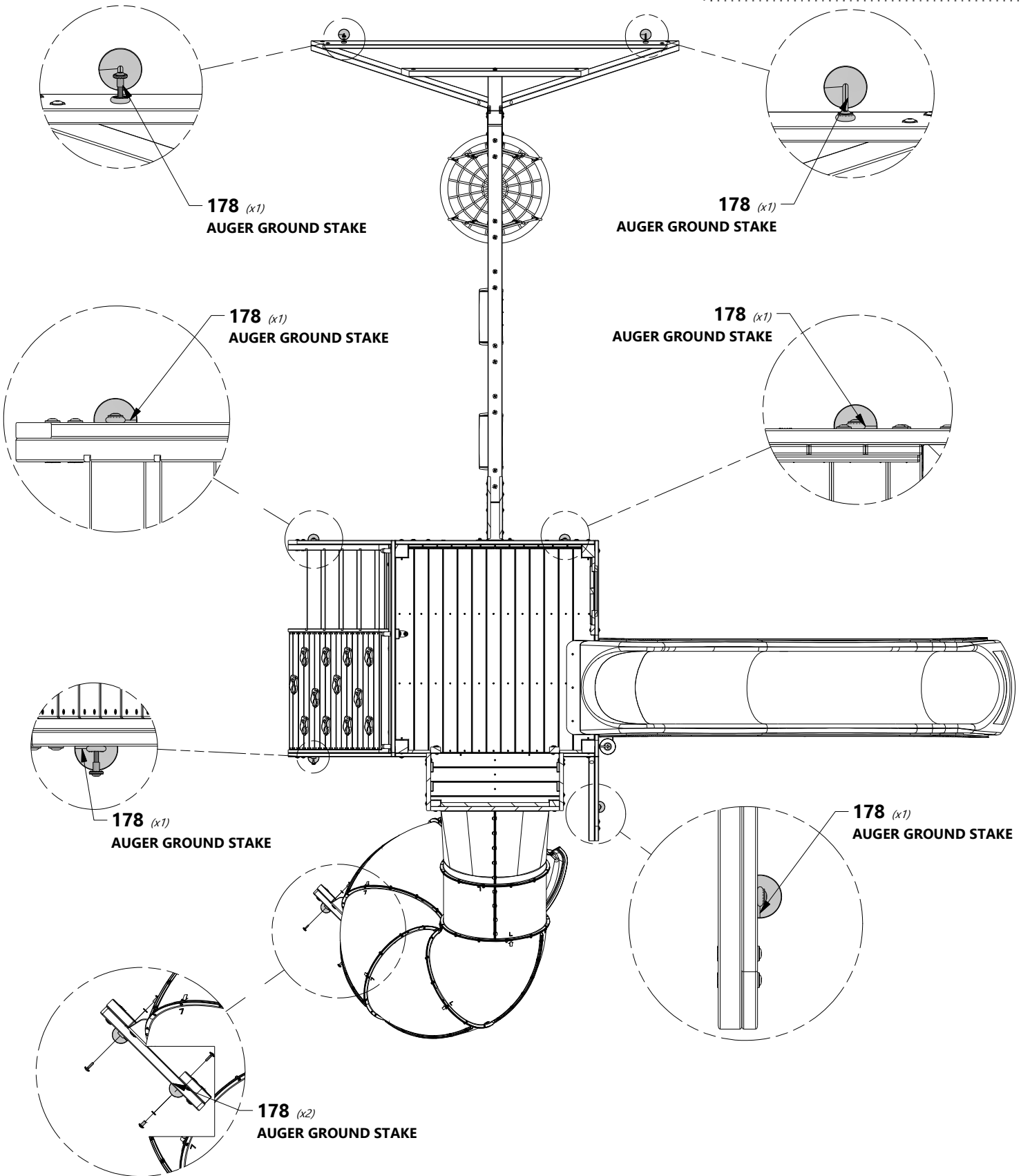

178 (x1)
AUGER GROUND STAKE

178 (x1)
AUGER GROUND STAKE

178 (x1)
AUGER GROUND STAKE

178 (x1)
AUGER GROUND STAKE

178 (x1)
AUGER GROUND STAKE

178 (x1)
AUGER GROUND STAKE

178 (x2)
AUGER GROUND STAKE

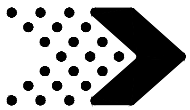

Phase 10

STEP 2



A100178 | AUGER GROUND STAKE
(x6)



H100468 | BOLT WH BLK
(x6) | 5/16x1



H100469 | NUT BARREL WH BLK
(x6) | 5/16x5/8



H100199 | WASHER LOCK EXT BLK
(x6) | 12x19

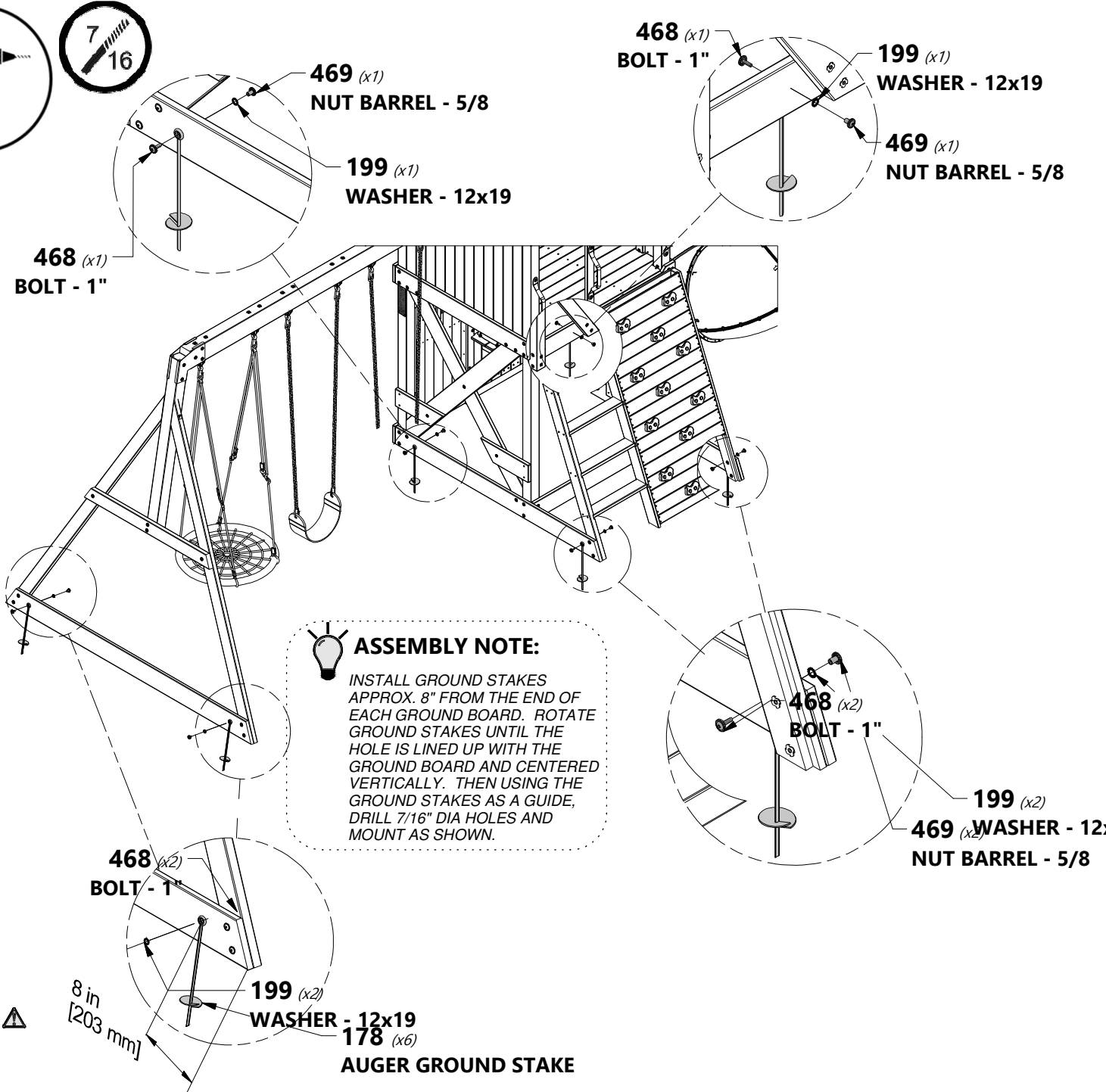

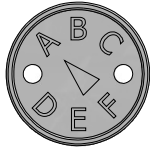
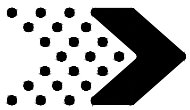

A100314 (x1) "A" REVISION TAG



H100202 | SCREW PWH BLK
(x2) 8x5/8

202 (x2)
SCREW - 5/8"

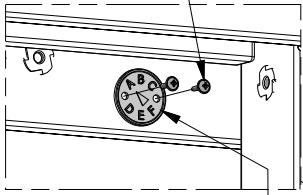

314 (x1)
"A" REVISION TAG

