

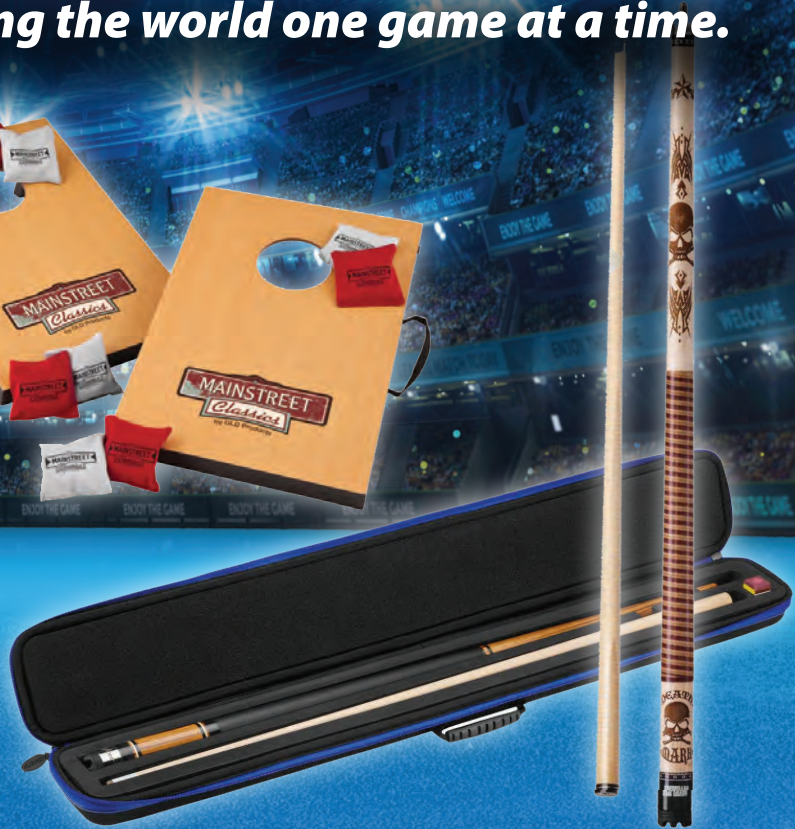

GLD[®]
P R O D U C T S

Entertaining the world one game at a time.



"Games have the potential to entertain and engage individuals and communities worldwide."





Dear Valued Customer,

From humble beginnings in a south Milwaukee Tavern, Great Lakes Dart Manufacturing has grown to become a premier name in darts, gaming tables, and billiards. For nearly 40 years, we have paved the way in dart games and technology, as well as in other areas of gaming culture.

Our story begins in 1981, when five friends and business partners banded together to drive more traffic into their bar. Seeing the hottest trends leaning towards a growing darts game, they quickly capitalized. Soon there were dartboards in every local establishment and players were forming dart leagues of their own. The leagues and game itself became so popular, local owners began coming to the newly named English Darts South for supplies.

After a \$100 investment, we had our first inventory and were the talk of the darting scene. As the decade rolled on, the darts game picked up more steam and quickly became one of the fastest growing sports in America. Quickly outgrowing our original home, we moved several times before settling on our home to this day in Muskego, where we inhabit a 60,000 ft² warehouse.

The key to our continued success is our willingness to take risks. Before the boom period in darting, we invested heavily into the novel idea of soft tip darts for use with electronic dartboards. These revolutionary dart boards would keep score for you and add a brand new flash to a very traditional game. Though many darters were content to continue enjoying their favorite game the way they always had, with steel points and bristle boards, casual fans of darts leapt at the idea of a faster and more convenient way to play.

After seeing the explosive growth in soft tip darts, we sought other means to get people playing games, eventually expanding into high quality and affordable billiard cues. Our new warehouse allowed the storage of much larger inventory such as full-sized game tables including pool, air hockey, and foosball. When exploring these new game tables, the new ideas continued with a revolution in home entertainment: the Pockey™ Two-in-One Game Table.

Great Lakes Darts Manufacturing has not shied away from leading the way in innovation across all disciplines of entertainment room games and boldly looks ahead to the next trends and big ideas to be had.

Sincerely,
Marilyn Hempel



GLD Products' current location in Muskego, Wisconsin.



Great Lakes Dart Manufacturing, Inc.

S84 W19093 Enterprise Drive
Muskego, WI 53150

(262) 679-8730
(800) 225-7593

(262) 679-8738
(800) 841-6944

www.gldproducts.com
support@gldproducts.com

/GLDProducts

@ViperDarts

/GLDProductsMfg

@GLDProductsCom

Table of Contents

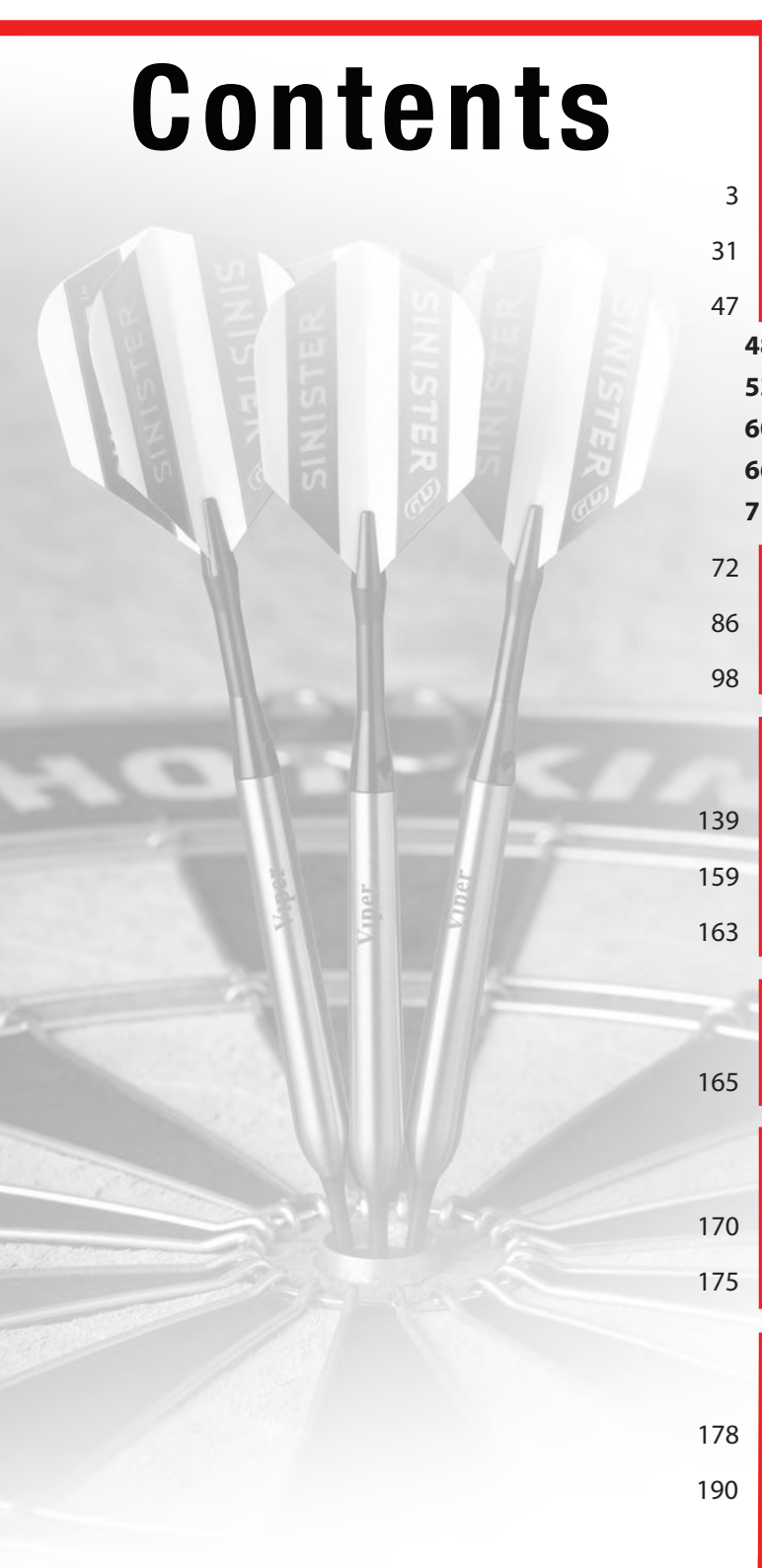

DARTS



- 3 Viper® Soft Tip Darts
- 31 Viper® Steel Tip Darts
- 47 Additional Brands
- 48 Fat Cat® Soft Tip Darts**
- 53 Fat Cat® Steel Tip Darts**
- 60 Elkadart® Soft Tip Darts**
- 66 Elkadart® Steel Tip Darts**
- 71 Laserdart® Darts**
- 72 Flights, Shafts & Dart Accessories
- 86 Casemaster® Dart Cases
- 98 Dartboards & Cabinets

BILLIARDS



- 139 Cues
- 159 Billiard Cases
- 163 Billiard Accessories

HOME CASINO



- 165 Poker Tables, Chips & Accessories

MAINSTREET CLASSICS™



- 170 Board Games
- 175 Table Top Table Games

TABLE GAMES



- 178 Billiard, Hockey & Foosball Tables
- 190 Table Game Accessories

NEW PRODUCT

SKIP AHEAD TO CHECK OUT THESE NEW ITEMS»



FLUX CONVERSION DARTS
Found on pages 4, 32



SUPPORT OUR TROOPS DARTS
Found on page 48



COOL MOLDED DART FLIGHTS
Found on page 73



FLIGHTS
Found on page 73 - 74



SHAFTS
Found on page 80, 82 - 83



NOMAD DART CASES
Found on page 86



SENTINEL ART SERIES DART CASES
Found on page 87



PLAZMA, PLUS & PRO DART CASES
Found on page 88 - 89



SPORT DART CASES
Found on page 89



SENTINEL AMERICAN FLAG CASE
Found on page 90



OBSIDIAN SISAL DARTBOARD
Found on page 112



PRO SISAL DARTBOARD CENTERS
Found on page 127



VAULT DELUXE DARTBOARD CABINET SET
Found on page 121

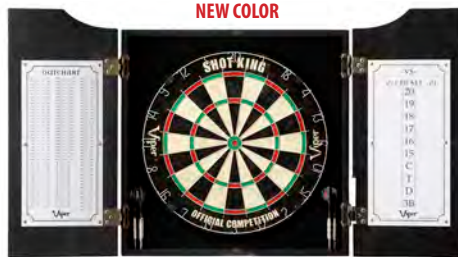

HUDSON ALL-IN-ONE DART CENTER BLACK
Found on page 122



GUARDIAN DARTBOARD SURROUND
Found on page 128



DEFENDER CORK SURROUNDS
Found on page 128 - 129

NEW COLOR



ILLUMISCORE SCOREBOARD
Found on page 133



QUICKFIT DARTBOARD MOUNTING KIT
Found on page 135

NEW COLORS



SILVERCUP BILLIARD CHALK
Found on page 163



EDGE DARTBOARD THROWLINES
Found on page 138



UNDERGROUND SINISTER BILLIARD CUE
Found on page 150



PARALLAX CUE CASES
Found on page 159

SOFT TIP



FLIGHT

Flights are available in a variety of shapes, sizes and designs. A player's throw velocity should determine what style of flight will work best. Experiment with different flight shapes until you find the one that works best for you. Flights allow you to personalize the look of your darts.

SHAFT

The shaft provides spacing between the flight and the barrel. Shafts are manufactured from a number of different materials like nylon, aluminum or polycarbonate in varying lengths. Choose a shaft which allows a comfortable feel and consider flight trajectory. For maximum stability select the shortest shaft that is comfortable for you.

BARREL

Varying widely in weight, length, grip and diameter, the barrel of a dart should be chosen to match your style of grip and throw. Barrels are generally made of alloy, nickel silver or tungsten. Alloy and nickel silver barrels are less expensive than tungsten, but tend to be wider in circumference. Tungsten barrels offer the advantage of a much slimmer dart, which can yield closer groupings, increasing your scores.

TIP

The end of the dart that makes contact with the board. Soft tip darts feature a more flexible tip made from various polymers designed for modern electronic dartboards. Soft tips can come in a variety of shapes and colors due to their construction. They may also range in durability, with the toughest tips featuring a reinforced inner core to strengthen it against damage. Soft tips are easy and cost efficient to replace and it is always a good idea to have some extras on hand just in case.



DARTS



21-1225-20

21-1226-20

21-1227-20

21-1228-20

21-1229-20

21-1230-20



VIPER **BLACK** **NEW PRODUCT**
FLUX

SOFT or STEEL TIP

The exclusive Viper Black Flux 90% Tungsten Conversion Dart Set comes with a set of steel tip converter points and soft tips. The high quality 90% Tungsten barrels are perfect for anyone looking for a professional dart sets.

- BARRELS** 3 90% Tungsten
- SHAFTS** 3 Viperlock Aluminum with locking hole
- FLIGHTS** 6 V-100 Slim
- TIPS** 3 2BA Tufflex, 3 Flux Aluminum
- WEIGHT** 20 Grams
- WARRANTY** Lifetime barrel warranty



(Accessories Included)

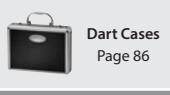

Dart Cases
Page 86



**90%
TUNGSTEN**

**DIAMOND CUT
TUNGSTEN**

**VIPER
PITBULL**

SOFT TIP

This savage, slim dart has attitude that will leave the competition paralyzed! Get ready for some fierce action with the Pitbull's intricate diamond cut tungsten barrel.

- BARRELS** 3 90% Tungsten diamond cut
- SHAFTS** 3 Yukon Aluminum Spinster™ with locking hole
- FLIGHTS** 6 V-Lux
- TIPS** 16 2BA Tufflex
- WEIGHT** 18 Grams
- CASE** Viper® TacTech
- TOOL** Dart mechanic wrench
- WARRANTY** Lifetime barrel warranty

21-2003-18

21-2004-18

21-2005-18

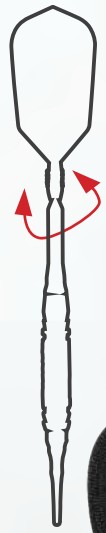

ALUMINUM SPINSTER™ SHAFT ALLOWS THE FLIGHT TO MOVE OUT OF THE WAY FOR LESS DEFLECTION.



(Accessories Included)

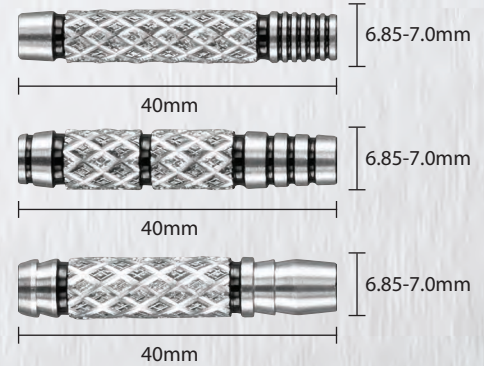



21-3401-18



21-3403-18



21-3407-18



LOCKING HOLE



Available in Steel Tip
Page 35

VIPER[®] DESPERADO

SOFT TIP

Desperado darts have a knurled grip for a relaxed, yet confident hold. Deep grooves have been added to the barrel for a touch of style.

- BARRELS** 3 80% Tungsten cross cut
- SHAFTS** 3 Aluminum with locking hole
- FLIGHTS** 6 V-Lux
- TIPS** 15 2BA Tufflex
- WEIGHT** 18 Grams
- CASE** Viper[®] TacTech
- WARRANTY** Lifetime barrel warranty

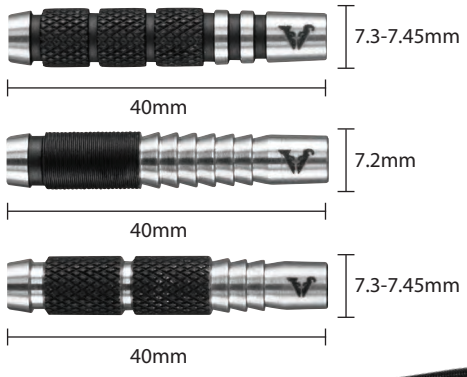

(Accessories Included)





21-2402-18



21-2404-18



LOCKING HOLE



21-2405-18



Replacement Shafts
Page 82

VIPER JAGUAR

SOFT TIP

These darts feature an impressive 80% tungsten content for extra slim barrels necessary for tight groupings. Jaguar's black coating accented with red stripes offers a stylish dart.



- BARRELS** 3 80% Tungsten knurled
- SHAFTS** 3 Aluminum diamond cut with locking hole
- FLIGHTS** 6 V-Lux
- TIPS** 15 2BA Tufflex
- WEIGHT** 18 Grams
- CASE** Viper® TacTech
- TOOL** Dart mechanic wrench
- WARRANTY** Lifetime barrel warranty

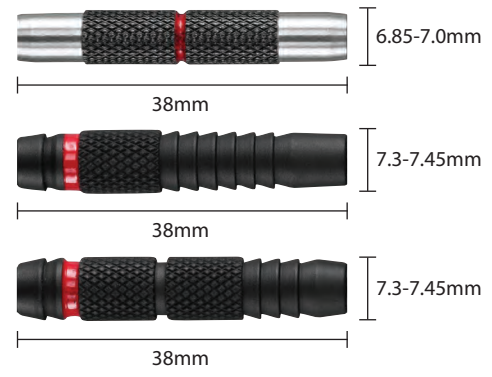

(Accessories Included)



Replacement Shafts Page 83

21-3275-16

21-3277-18

21-3279-16
21-3279-18

21-3281-18

VIPER ASTRO

SOFT TIP

Slim 80% tungsten barrels feature symmetrical knurling and hand painted rings, complemented by high-profile diamond cuts for a heavily textured grip, ensuring that this barrel will take your game into orbit! Includes a durable aluminum case to protect your darts.

- BARRELS** 3 80% Tungsten diamond cut
- SHAFTS** 3 Aluminum diamond cut with locking hole
- FLIGHTS** 6 V-Lux
- TIPS** 15 2BA Tufflex
- WEIGHT** Last two digits denote weight (Item #: XX-XXXX-XX)
- CASE** Viper® TacTech
- TOOL** Dart mechanic wrench
- WARRANTY** Lifetime barrel warranty

80% TUNGSTEN

DIAMOND CUT TUNGSTEN

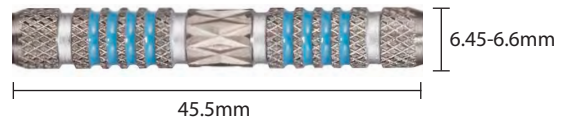

(Accessories Included)





21-2051-20



21-2054-18



Comes in Steel Tip
Page 36

VIPER® V-FACTOR

SOFT TIP

These darts are packed with features starting with the barrel, fashioned from 90% tungsten and 10% nickel. Grooves, knurling, and high-tech design give this sleek dart an easy-to-grip barrel. The V-Factor is topped off with 150 micron thick flights for long-lasting durability.

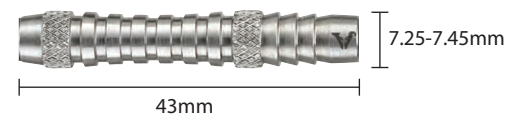
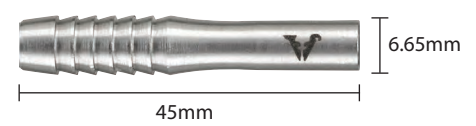

- BARRELS** 3 90% Tungsten
- SHAFTS** 3 Aluminum with locking hole
- SPARE SHAFTS** 3 Convex nylon
- FLIGHTS** 3 Viper® 150, 3 V-100
- TIPS** 9 2BA Tufflex
- WEIGHT** Last two digits denote weight (Item #: XX-XXXX-XX)
- CASE** Deluxe Dart Pal®
- TOOL** Dart mechanic wrench
- KIT** 3 Flight protectors
- WARRANTY** Lifetime barrel warranty



(Accessories Included)



21-3501-16



21-3503-18



21-3504-18

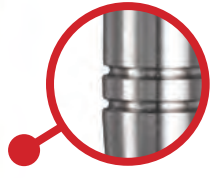

Comes in Steel Tip
Page 34

VIPER UPDATED DESIGN

SINISTER

SOFT TIP

Sinister darts feature an ultra smooth 95% tungsten barrel. The unbeatable barrel is precision machined for perfect balance and the darts come with heavy-duty 100 micron aerodynamic flights.



- BARRELS** 3 95% Tungsten
- SHAFTS** 3 Aluminum with locking hole
- SPARE SHAFTS** 3 Convex nylon
- FLIGHTS** 6 V-100
- TIPS** 6 2BA Tufflex
- WEIGHT** Last two digits denote weight (Item #: XX-XXXX-XX)
- PACKAGE** Display box
- TOOL** Dart mechanic wrench
- WARRANTY** Lifetime barrel warranty

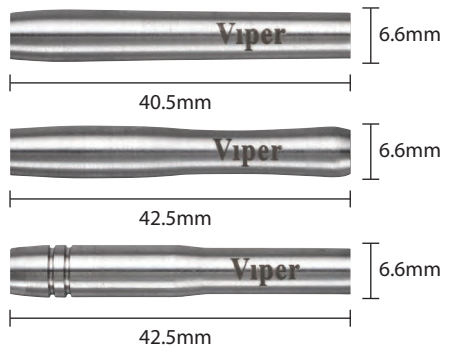

(Accessories Included)



21-4801-18



21-4802-16
21-4802-18



21-4803-16

**DIAMOND CUT
TUNGSTEN**



VIPER
DIAMOND

SOFT TIP

Among the highest tungsten content we offer, the Viper® Diamond darts feature an exceptionally thin barrel profile for incredibly tight shot groupings to drive your way to victory. The signature diamond-cut grip will allow you to perfect your throws and shine on.

- BARRELS** 3 90% Tungsten diamond cut
- SHAFTS** 3 Aluminum diamond cut with locking hole
- SPARE SHAFTS** 3 Convex nylon
- FLIGHTS** 3 V-Lux, 3 V-100
- TIPS** 9 2BA Tufflex
- WEIGHT** Last two digits denote weight (Item #: XX-XXXX-XX)
- CASE** Deluxe Dart Pal®
- TOOL** Dart mechanic wrench
- KIT** 3 Flight protectors
- WARRANTY** Lifetime barrel warranty

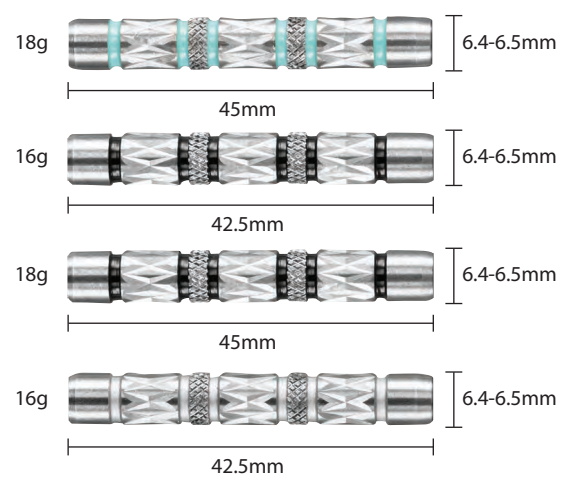

(Accessories Included)



21-2501-16
21-2501-18



21-2502-18



21-2504-16
21-2504-18



Replacement Shafts
Page 82

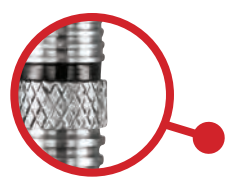

80% TUNGSTEN

VIPER GRIM REAPER

SOFT TIP

Strike fear in the heart of every dart opponent. Viper® Grim Reapers are designed for the experienced player, this high quality tungsten dart has hand painted rings and unique contouring for excellent grip and accurate release.

- BARRELS** 3 80% Tungsten knurled
- SHAFTS** 3 Aluminum Starburst with locking hole
- SPARE SHAFTS** 3 Convex nylon
- FLIGHTS** 3 V-Lux, 3 V-100
- TIPS** 9 2BA Tufflex
- WEIGHT** Last two digits denote weight (Item #: XX-XXXX-XX)
- CASE** Deluxe Dart Pal®
- TOOL** Dart mechanic wrench
- KIT** 3 Flight protectors
- WARRANTY** Lifetime barrel warranty

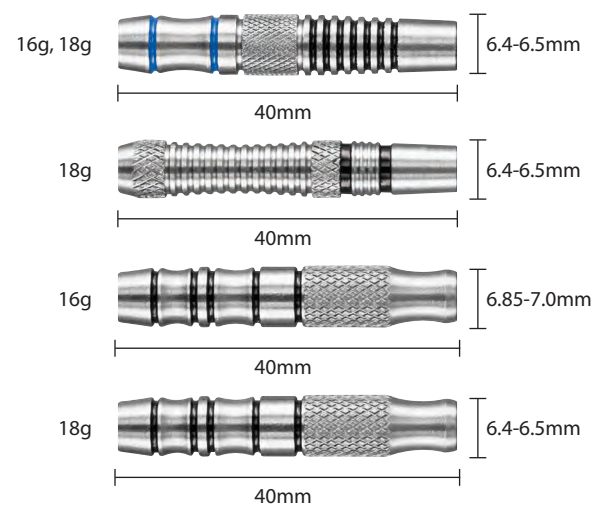



**90%
TUNGSTEN**

**DIAMOND CUT
TUNGSTEN**

VIPER ELEMENT

SOFT TIP

Viper® Element dart barrels are comprised of 90% tungsten. It allows for the slimmest barrel possible for tighter groupings while maintaining ultimate precision and weight.

- BARRELS** 3 90% Tungsten diamond cut
- SHAFTS** 3 Aluminum diamond cut with locking hole
- SPARE SHAFTS** 3 Convex nylon
- FLIGHTS** 3 V-75, 3 V-100
- TIPS** 9 2BA Tufflex
- WEIGHT** 18 Grams
- CASE** Deluxe Dart Pal®
- TOOL** Dart mechanic wrench
- KIT** 3 Flight protectors
- WARRANTY** Lifetime barrel warranty



LOCKING HOLE

21-2601-18

21-2603-18

21-2605-18



(Accessories Included)

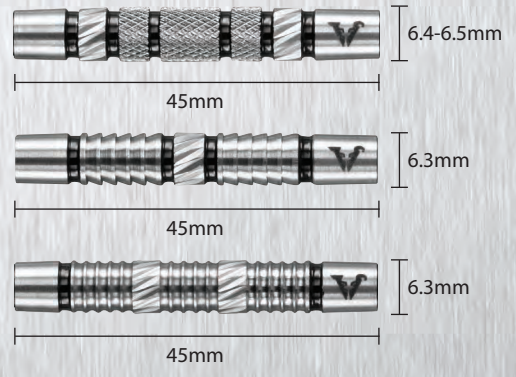



21-2251-18



21-3175-18



Comes in Steel Tip
Page 36

VIPER BULLY

SOFT TIP

Stand undaunted in the face of your foes with the Viper® Bully darts, featuring 80% tungsten barrels. Revolutionary knurled barrels come in three styles to suit your need. Impact the board with unrelenting force to ensure bounce-outs are a thing of the past.

- BARRELS** 3 80% Tungsten knurled
- SHAFTS** 3 Aluminum Color Master with locking hole
- SPARE SHAFTS** 3 Convex nylon
- FLIGHTS** 3 V-Lux, 3 V-100
- TIPS** 9 2BA Tufflex
- WEIGHT** 18 Grams
- CASE** Deluxe Dart Pal®
- TOOL** Dart mechanic wrench
- KIT** 3 Flight protectors
- WARRANTY** Lifetime barrel warranty

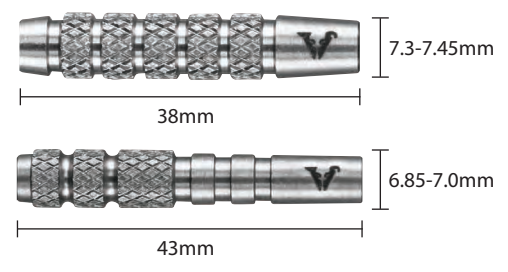

(Accessories Included)



VIPER RANGER

SOFT TIP 21-2915-18

The Viper® Ranger features slim barrels with hand painted rings and intricate knurling in a variety of styles. You are sure to hit your mark with the Ranger.

- BARRELS** 3 80% Tungsten
- SHAFTS** 3 Aluminum Color Master with locking hole
- SPARE SHAFTS** 3 Convex nylon
- FLIGHTS** 3 V-75, 3 V-100
- TIPS** 6 2BA Tufflex
- WEIGHT** Last two digits denote weight (Item #: XX-XXXX-XX)
- PACKAGE** Display box
- TOOL** Dart mechanic wrench
- WARRANTY** Lifetime barrel warranty

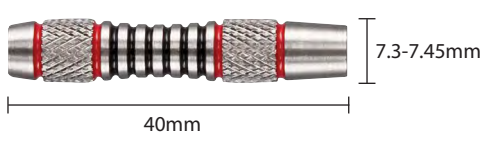

(Accessories Included)

VIPER SIDEWINDER

UPDATED DESIGN

SOFT TIP

The Sidewinder features a regal and slim tungsten design for those who want to look and play great. Unique grip points and lightweight aluminum shafts provide extra control and help this dart glide through the air with ease and balance.

- BARRELS** 3 80% Tungsten
- SHAFTS** 3 Aluminum with locking hole
- SPARE SHAFTS** 3 Convex nylon
- FLIGHTS** 6 V-100
- TIPS** 6 2BA Tufflex
- WEIGHT** 18 Grams
- PACKAGE** Display box
- TOOL** Dart mechanic wrench
- WARRANTY** Lifetime barrel warranty

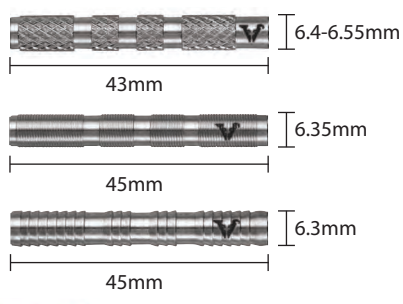

(Accessories Included)

21-3225-18 21-3226-18 21-3227-18

VIPER® WINGS

SOFT TIP 21-1975-16

The Viper® Wings 80% tungsten dart comes with its own special edition Deluxe Dart Pal® case that has room for all the extra tools needed for dart and shaft maintenance. Tough aluminum shafts make this dart a great choice. Flutter toward victory with your Wings.

- BARRELS** 3 80% Tungsten
- SHAFTS** 3 Aluminum with locking hole
- SPARE SHAFTS** 3 Convex nylon
- FLIGHTS** 6 V-100
- TIPS** 9 2BA Tufflex
- WEIGHT** 16 Grams
- CASE** Special Edition Deluxe Dart Pal®
- TOOL** Dart mechanic wrench
- KIT** 3 Flight protectors
- WARRANTY** Lifetime barrel warranty

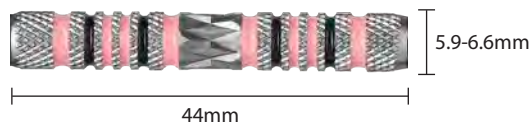

VIPER® DESERT ROSE

SOFT TIP 20-0600-16

Desert Rose features unique contours for excellent grip and has hand painted rings. It also features a printed dart case with original flower design. Stand out like a lone bloom in the desert when you throw the Desert Rose.

- BARRELS** 3 Nickel silver with pink grooves
- SHAFTS** 3 Aluminum Color Master with locking hole
- SPARE SHAFTS** 3 Convex nylon
- FLIGHTS** 6 V-Lux
- TIPS** 9 2BA Tufflex
- WEIGHT** 16 Grams
- CASE** Special Edition Deluxe Dart Pal®
- TOOL** Dart mechanic wrench
- KIT** 3 Flight protectors
- WARRANTY** Lifetime barrel warranty

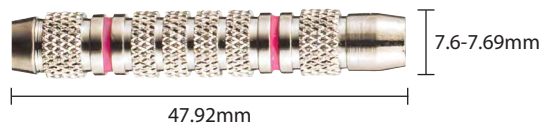



VIPER VANITY

SOFT TIP

The Viper® Vanity soft tip darts are packed with features starting with the barrel, fashioned with specially coated alloy. The barrels feature audacious graphics, with your choice of style to match your personality.

- BARRELS** 3 Coated alloy with hand painted rings and metallic printed barrel logos
- SHAFTS** 3 Aluminum with locking hole
- SPARE SHAFTS** 3 Convex nylon
- FLIGHTS** 6 V-100
- TIPS** 9 2BA Tufflex
- WEIGHT** 16 Grams
- CASE** Special Edition Deluxe Dart Pal®
- TOOL** Dart mechanic wrench
- KIT** 3 Flight protectors
- WARRANTY** Lifetime barrel warranty



DART DIVA
20-0313-16

DART BITCH
20-0317-16



(Accessories Included)



Comes in Steel Tip
Page 40

VIPER V GLO

SOFT TIP

The V Glo line has colors that pop like no other dart! Show off your skills and your great sense of style with these bright darts. You are guaranteed to make a statement.

- BARRELS** 3 Front weighted, multi-grooved, color coated alloy
- SHAFTS** 3 Aluminum with locking hole
- FLIGHTS** 3 V-100
- TIPS** 3 2BA Tufflex
- WEIGHT** 18 Grams
- PACKAGE** Hangsell
- WARRANTY** Lifetime barrel warranty



20-4301-18

20-4302-18

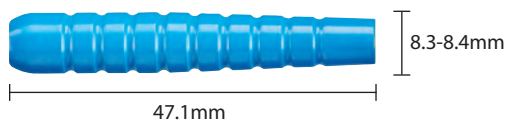



Nickel plated
20-0912-16
16 gm adjustable to 17 or 18 gm
20-0937-16
16 gm adjustable to 18 or 19 gm



Nickel plated
20-0915-16
16 gm adjustable to 17 or 18 gm
20-0939-16
16 gm adjustable to 18 or 19 gm

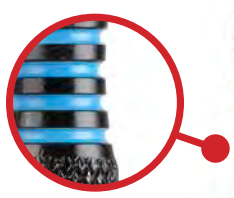

Coated alloy
20-0916-16
16 gm adjustable to 17 or 18 gm
20-0940-16
16 gm adjustable to 18 or 19 gm



With Add-A-Gram
Coated alloy
20-0918-16
16 gm adjustable to 17 or 18 gm
20-0942-16
16 gm adjustable to 18 or 19 gm

VIPER BOBCAT

SOFT TIP

The Bobcat has the versatility of adjustable weights. It can be used on its own or with an add-a-gram, adding weight to the front of the barrel. Players can use the same barrel but change the weight to suit individual league and tournament regulations. Darts come with add-a-grams attached.

- BARRELS** 3 Nickel plated or coated alloy, grooved and knurled
- SHAFTS** 3 Aluminum with locking hole
- SPARE SHAFTS** 3 Convex nylon
- FLIGHTS** 6 V-100 Lumicore
- TIPS** 3 1/4" Tufflex
- TIPS** 6 2BA Tufflex
- WEIGHTS** 6 Adjustable add-a-gram weights
- CASE** Deluxe Dart Pal®
- TOOL** Dart mechanic wrench
- KIT** 3 Flight protectors
- WARRANTY** Lifetime barrel warranty



(Accessories Included)

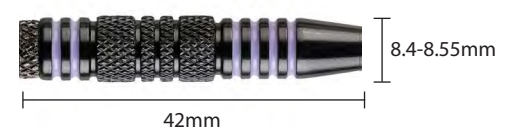
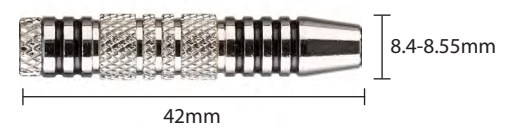
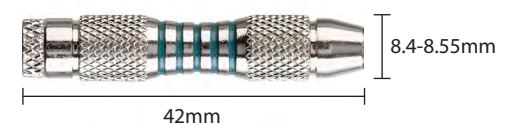



ALUMINUM SPINSTER™
SHAFT ALLOWS THE FLIGHT
TO MOVE OUT OF THE WAY
FOR LESS DEFLECTION.



LOCKING HOLE



20-1002-18



20-1003-18



20-1005-18

Dart Cases
Page 86 

Comes in
Steel Tip
Page 41 

Replacement
Shafts
Page 82 

VIPER UPDATED DESIGN

THE FREAK

SOFT TIP

The Freak always stands out from the crowd. It is made of nickel silver and features durable grip points for the ultimate touch. The coating on these will not wear off after years of use.

- BARRELS** 3 Nickel silver with durable coating
- SHAFTS** 3 Yukon Aluminum Spinster with locking hole
- SPARE SHAFTS** 3 Viperlock
- FLIGHTS** 6 V-100
- TIPS** 6 2BA Tufflex
- WEIGHT** 18 Grams
- PACKAGE** Display box
- TOOL** Dart mechanic wrench
- WARRANTY** Lifetime barrel warranty



(Accessories Included)

VIPER **UPDATED DESIGN**
WIZARD

SOFT TIP

The Wizard offers a very deep and edgy knurling, making it very easy to grip. This dart will not slip out of your hold. Feel the power of the Wizard.

- BARRELS** 3 Alloy diamond cut, knurled with painted grooves
- SHAFTS** 6 Viperlock Shade
- FLIGHTS** 6 V-100
- TIPS** 6 2BA Tufflex
- WEIGHT** 18 Grams
- TOOL** Dart mechanic wrench
- WARRANTY** Lifetime barrel warranty

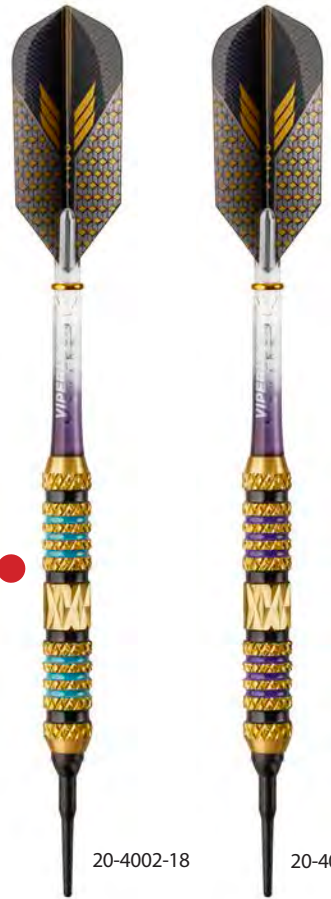
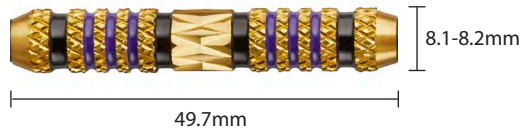
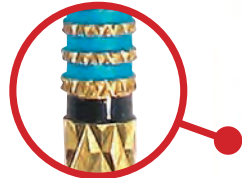

DIAMOND CUT



(Accessories Included)

Dart Cases
Page 86

VIPER
BLACK MAGIC

SOFT TIP

Precision balancing gives the Viper® Black Magic darts the ability to reach their target smoothly and accurately. The Black Magic darts features black coated for a sleek look and knurled for excellent grip.

- BARRELS** 3 Coated alloy grooved and knurled
- SHAFTS** 3 Aluminum Color Master with locking hole
- FLIGHTS** 3 V-Lux
- TIPS** 3 2BA Tufflex
- WEIGHT** 18 Grams
- PACKAGE** Hangsell
- WARRANTY** Lifetime barrel warranty



LOCKING HOLE

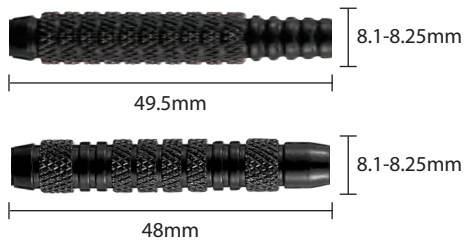



Dart Cases
Page 86

20-1701-16
20-1701-18

20-1702-16
20-1702-18

20-1703-16
20-1703-18

20-1704-16
20-1704-18



VIPER **UPDATED DESIGN**
BLACK ICE

SOFT TIP

Your opponent will feel the deadly chill of this cool, textured dart. Black Ice will freeze them in their tracks! This black coated beauty features vibrant enhancement bands for stylish grip barrels.

- BARRELS** 3 Coated alloy knurled and grooved with vibrant enhancement bands
- SHAFTS** 3 Aluminum Color Master with locking hole
- SPARE SHAFTS** 3 Convex nylon
- FLIGHTS** 3 V-Lux, 3 V-100
- TIPS** 6 2BA Tufflex
- WEIGHT** Last two digits denote weight (Item #: XX-XXXX-XX)
- PACKAGE** Display box
- TOOL** Dart mechanic wrench
- WARRANTY** Lifetime barrel warranty

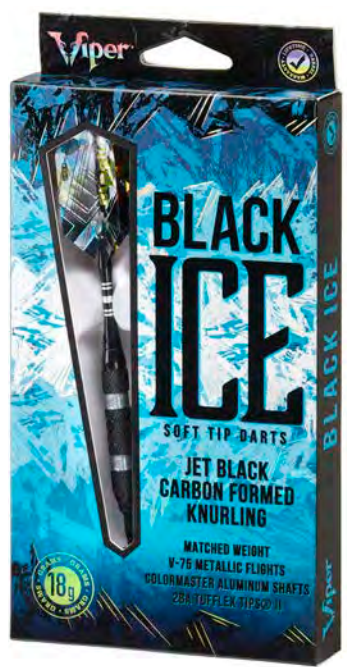

(Accessories Included)



 Comes in Steel Tip
Page 43

 Dart Cases
Page 86

VIPER[®] COMIX

SOFT TIP **20-2201-18**

Viper[®] darts have been created with an insider's knowledge of the darter's needs. The Comix series has been designed with smartly situated grooves on brightly colored barrels. They are balanced and weighted, making you the slick super hero you want to be. Comes with a matching set of flights.

- BARRELS** 3 Coated alloy with pineapple cut grooves
- SHAFTS** 3 Aluminum with locking hole
- SPARE SHAFTS** 3 Convex nylon
- FLIGHTS** 6 V-75
- TIPS** 6 2BA Tufflex
- WEIGHT** 18 Grams
- PACKAGE** Display box
- TOOL** Dart mechanic wrench
- WARRANTY** Lifetime barrel warranty



LOCKING HOLE

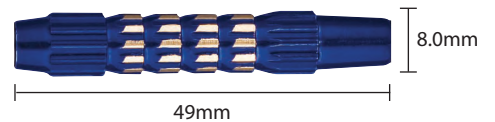

(Accessories Included)



LOCKING HOLE



20-2110-18



20-2111-18



20-2112-18



20-2113-18

VIPER WIND RUNNER

SOFT TIP

Let your dart game soar with the Wind Runner. The hand applied pearlized rings sharpen the look of this stylish nickel plated dart. It features grooved knurling for excellent grip. This champion dart glides high above the rest!

- BARRELS** 3 Nickel plated grooved knurling with vibrant enhancement bands
- SHAFTS** 3 Aluminum Color Master with locking hole
- FLIGHTS** 3 V-100
- TIPS** 3 2BA Tufflex
- WEIGHT** 18 Grams
- PACKAGE** Hangsell
- WARRANTY** Lifetime barrel warranty

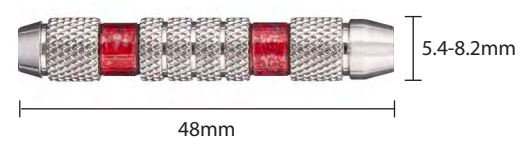

Dart Cases Page 86



ROCK & ROLL
20-3914-18



FATAL SHOT
20-3912-18

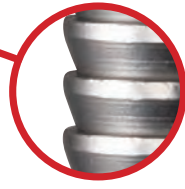

Dart Cases
Page 86

Comes in Steel Tip
Page 42

VIPER® UNDERGROUND

SOFT TIP

Intimidate your opponents and dominate your dart games with the Viper® Underground soft tip darts. Fashioned from tungsteel alloy, these darts have front-weighted barrels with grip-enhancing grooves, allowing your hand placement to remain consistent throw after throw.

- BARRELS** 3 Tungsteel alloy grooved
- SHAFTS** 3 Aluminum with locking hole
- SPARE SHAFTS** 3 Convex nylon
- FLIGHTS** 6 V-Lux
- TIPS** 6 2BA Tufflex
- WEIGHT** 18 Grams
- PACKAGE** Display box
- TOOL** Dart mechanic wrench
- WARRANTY** Lifetime barrel warranty

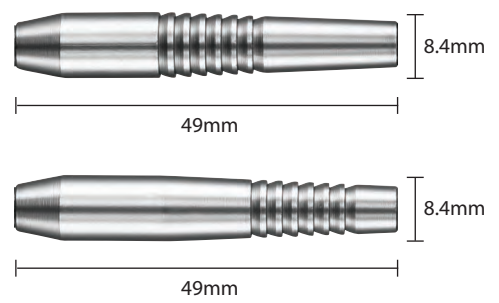

(Accessories Included)



20-0003-16
20-0003-18

20-0004-16
20-0004-18

20-0005-16
20-0005-18

20-0006-16
20-0006-18

20-0007-16
20-0007-18

20-0008-16
20-0008-18

20-0009-16
20-0009-18

VIPER[®] SURE GRIP

SOFT TIP

The #1 selling dart in our selection is a colorful addition to any darter's collection. Sure Grip rubber sleeves fit snugly over the barrel of the dart, offering excellent grip.

- BARRELS** 3 Nickel plated with rubberized, replaceable Sure Grip sleeves
- SHAFTS** 3 Aluminum Color Master with locking hole
- FLIGHTS** 3 V-75
- TIPS** 3 2BA Tufflex
- WEIGHT** Last two digits denote weight (Item #: XX-XXXX-XX)
- PACKAGE** Hangsell
- WARRANTY** Lifetime barrel warranty

SURE GRIP RUBBERIZED REPLACEMENT SLEEVES

COLORS 3 pcs. per bag, min. 5 bags

- BLACK** 37-2000-01
- RED** 37-2000-02
- BLUE** 37-2000-03
- PURPLE** 37-2000-06
- NEON ORANGE** 37-2000-09
- NEON GREEN** 37-2000-10
- NEON PINK** 37-2000-12

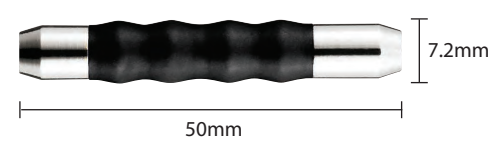

Dart Cases
Page 86



Comes in Steel Tip
Page 44

Dart Cases
Page 86

20-3700-18

20-3701-16

20-3702-18

20-3703-20

VIPER[®] SILVER THUNDER

SOFT TIP

The Viper[®] Silver Thunder darts are packed with features starting with the barrel, fashioned from nickel silver alloy. Constructing the darts in this fashion allows us to bring you tough, weighted barrels without breaking the bank. Nickel plating is a method that has been used in construction for its high end appearance and durability at a lower cost.

- BARRELS** 3 Nickel silver with painted rings and banded knurling
- SHAFTS** 3 Convex nylon
- FLIGHTS** 3 V-Lux
- TIPS** 3 2BA Tufflex
- WEIGHT** Last two digits denote weight (Item #: XX-XXXX-XX)
- PACKAGE** Hangsell
- WARRANTY** Lifetime barrel warranty

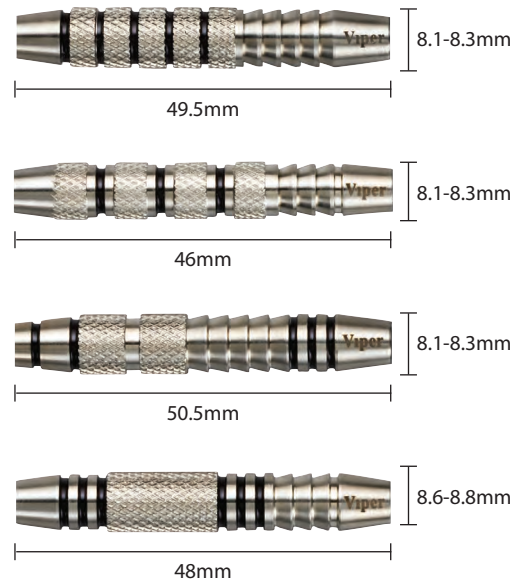



20-0104-20

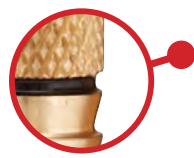

20-0106-18

VIPER UPDATED DESIGN
ELITE BRASS

SOFT TIP

Viper® Elite Brass darts are available in a variety of styles and weights. Great for the player who wants to experiment and find out what works best for them. Choose from smooth or knurled barrels, both with hand painted rings.

- BARRELS** 3 Brass with hand painted rings
- SHAFTS** 3 Nylon
- FLIGHTS** 3 V-75
- TIPS** 3 2BA Tufflex
- WEIGHT** Last two digits denote weight
(Item #: XX-XXXX-XX)
- PACKAGE** Hangsell
- WARRANTY** Lifetime barrel warranty

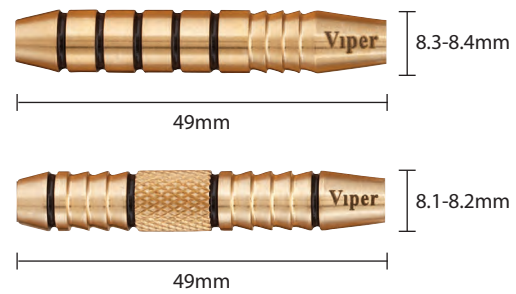

Comes in Steel Tip 
 Page 45



TUNGSTEN BEE

SOFT TIP

The Viper® Tungsten Bee soft tip darts, designed for use with either electronic dart boards or most sisal dart boards. These diminutive darts are packed with features starting with the barrel, fashioned from 80% tungsten and 20% nickel. Tungsten is a very dense metal, able to create shorter darts with the same weight as lighter metals; this allows a smaller dart without sacrificing control, increasing your scores.

- BARRELS** 3 80% Tungsten knurled and grooved with hand painted rings
- SHAFTS** 3 Aluminum with locking hole
- FLIGHTS** 3 V-Lux
- TIPS** 3 2BA Tufflex
- WEIGHT** 18 Grams
- CASE** Super Bee Casemaster® in clam
- WARRANTY** Lifetime barrel warranty



LOCKING HOLE



SUPER BEE DART CASE
36-0556-01



EXTRA SHORT SHAFT
21-3100-18



SUPER BEE

SOFT TIP

Great things come in small packages with the Viper® Super Bee soft tip darts, designed for use with either electronic dart boards or most sisal dart boards. These diminutive darts are packed with features starting with the barrel, fashioned from your choice of materials.

- BARRELS** 3 Alloy nickel plated or black anti-slip barrels
- SHAFTS** 3 Aluminum with locking hole
- FLIGHTS** 3 V-Lux
- TIPS** 3 2BA Tufflex
- WEIGHT** 16 Grams
- PACKAGE** Clam pack
- WARRANTY** Lifetime barrel warranty



LOCKING HOLE

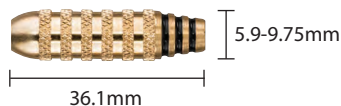

ALLOY
20-1201-16



NICKEL PLATED
20-1202-16



BLACK ALLOY
20-1203-16

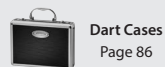

Dart Cases
Page 86



SPINNING BEE

SOFT TIP

The only bees with a rotating shaft. The Viper® Spinning Bee darts feature a vibrant color coating and wide knurling for superb grip.

- BARRELS** 3 Color coated alloy knurled and grooved
- SHAFTS** 3 Spinster™ tops
- FLIGHTS** 3 V-100 Oryx
- TIPS** 3 2BA Tufflex
- WEIGHT** 16 Grams
- CASE** Super Bee Casemaster® in clam
- WARRANTY** Lifetime barrel warranty

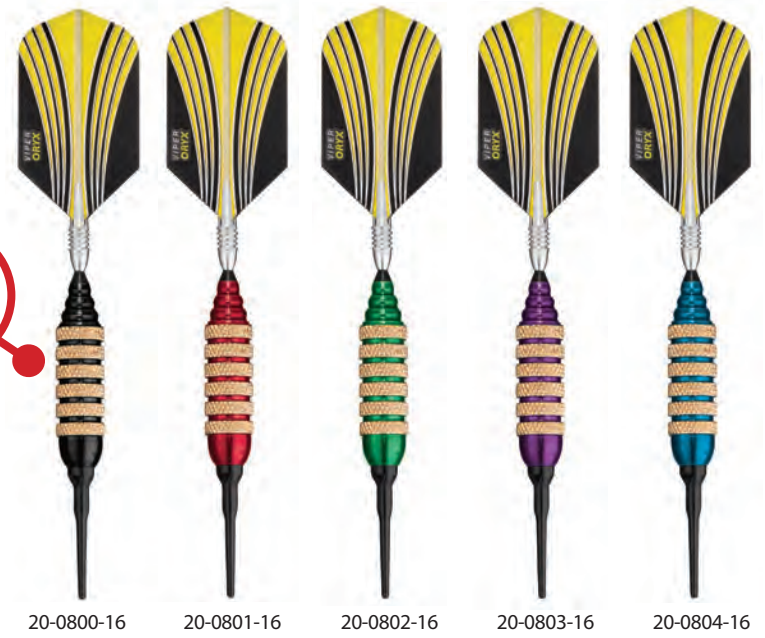

20-0800-16 20-0801-16 20-0802-16 20-0803-16 20-0804-16



SUPER BEE DART CASE
36-0556-01



SPINSTER™ REPLACEMENT TOP
35-7850-00
Page 82

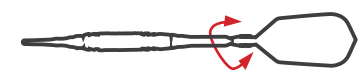
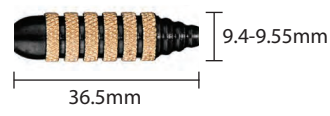

ALUMINUM SPINSTER™ SHAFT ALLOWS THE FLIGHT TO MOVE OUT OF THE WAY FOR LESS DEFLECTION.



ATOMIC BEE

SOFT TIP

Viper® Atomic Bees are small yet extremely accurate. Each dart features a vibrant color coating and is knurled for easy grip.

- BARRELS** 3 Color coated alloy anti-slip grooved and knurled
- SHAFTS** 3 Aluminum with locking hole
- FLIGHTS** 3 V-Lux
- TIPS** 3 2BA Tufflex
- WEIGHT** 16 Grams
- PACKAGE** Clam pack
- WARRANTY** Lifetime barrel warranty



20-1350-16 20-1351-16 20-1352-16 20-1353-16 20-1354-16

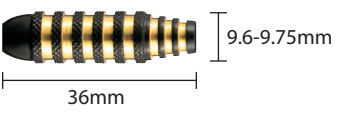

LOCKING HOLE



VIPER MIGHTY MITE

SOFT TIP **20-4444**

Only 4 1/2" in length, Mighty Mite darts feature a slim design for tight groupings and are knurled near the tip to prevent slipping.

- BARRELS** 3 Alloy
- SHAFTS** 3 Permanent steel wire
- FLIGHTS** 3 Micro
- TIPS** 3 2BA Tufflex
- WEIGHT** 5.4 Grams
- PACKAGE** Display box
- WARRANTY** Lifetime barrel warranty



VIPER TERMITE

SOFT TIP **20-5555**

Only 3" long! Termite darts feature a slim design for tight groupings and are knurled near the tip to prevent slipping. Flight slides into the top of barrel, no shaft needed.

- BARRELS** 3 Alloy bullet
- FLIGHTS** 3 Micro
- TIPS** 3 2BA Tufflex
- WEIGHT** 4.5 Grams
- PACKAGE** Display box
- WARRANTY** Lifetime barrel warranty



VIPER COMMERCIAL BAR DART

SOFT TIP **45 pieces per bag**

Soft tip bar darts are economical and durable with one piece molded flights, steel barrels, and 1/4" performance tips.

- BARRELS** Knurled coated steel
- SHAFTS** 1 Piece molded 1/4" Plastic flight and shaft
- TIPS** 1/4" Performance tip
- WEIGHT** 13 Grams



COMPLETE PIECE ITEM NUMBERS

45 pieces per bag

- | | |
|-------------------------|--------------------------|
| BLACK 37-1300-01 | BLUE 37-1300-03 |
| RED 37-1300-02 | YELLOW 37-1300-07 |

REPLACEMENT FLIGHTS

COLORS **100 per bag**

- | | |
|-------------------------|--------------------------|
| BLACK 34-5300-01 | BLUE 34-5300-03 |
| RED 34-5300-02 | YELLOW 34-5300-07 |

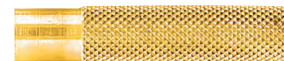

STEEL REPLACEMENT BARRELS
37-1302 | Sold per piece

STEEL TIP



FLIGHT

Flights are available in a variety of shapes, sizes and designs. A player's throw velocity should determine what style of flight will work best. Experiment with different flight shapes until you find the one that works best for you. Flights allow you to personalize the look of your darts.

SHAFT

The shaft provides spacing between the flight and the barrel. Shafts are manufactured from a number of different materials like nylon, aluminum or polycarbonate in varying lengths. Choose a shaft which allows a comfortable feel and consider flight trajectory. For maximum stability select the shortest shaft that is comfortable for you.

BARREL

Varying widely in weight, length, grip and diameter, the barrel of a dart should be chosen to match your style of grip and throw. Barrels are generally made of alloy, nickel silver or tungsten. Alloy and nickel silver barrels are less expensive than tungsten, but tend to be wider in circumference. Tungsten barrels offer the advantage of a much slimmer dart, which can yield closer groupings, increasing your scores.

TIP

The end of the dart that first enters the dartboard. For use with traditional sisal boards, steel tips are hardy and durable, and are incorporated into the construction of the barrel. Because of this, steel tips very rarely break and almost never need to be replaced. This built-in nature, coupled with its toughness allows you to repair steel tips as they accrue wear from hours of play. Some more professional darts feature a black oxide coating which is designed to better grip the sisal fibers and eliminate bounce outs.



DARTS



21-1225-20

21-1226-20

21-1227-20

21-1228-20

21-1229-20

21-1230-20



VIPER **BLACK** **NEW PRODUCT**
FLUX

SOFT or STEEL TIP

The exclusive Viper Black Flux 90% Tungsten Conversion Dart Set comes with a set of steel tip converter points and soft tips. The high quality 90% Tungsten barrels are perfect for anyone looking for a professional dart sets.

- BARRELS** 3 90% Tungsten
- SHAFTS** 3 Viperlock Aluminum with locking hole
- FLIGHTS** 6 V-100 Slim
- TIPS** 3 2BA Tufflex, 3 Flux Aluminum
- WEIGHT** 20 Grams
- WARRANTY** Lifetime barrel warranty



(Accessories Included)

Dart Cases
Page 86



Replacement Shafts
Page 82

23-2722-22

23-2724-24

23-2726-26

23-2728-28

VIPER BLITZ

STEEL TIP

Viper® Blitz darts are equipped with 95% tungsten slim barrels, allowing for tighter groupings and controlled weight range. Also, the Blitz features a variety of black painted grooves.

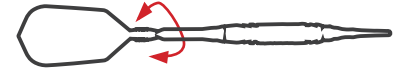

ALUMINUM SPINSTER™ SHAFT ALLOWS THE FLIGHT TO MOVE OUT OF THE WAY FOR LESS DEFLECTION.

- BARRELS** 3 95% Tungsten
- SHAFTS** 3 2BA Yukon Spinster™ with locking hole
- SPARE SHAFTS** 6 Viperlock Clear
- FLIGHTS** 6 V-Lux
- POINTS** Oxide coated steel
- WEIGHT** Last two digits denote weight (Item #: XX-XXXX-XX)
- CASE** Viper® TacTech
- WARRANTY** Lifetime barrel warranty

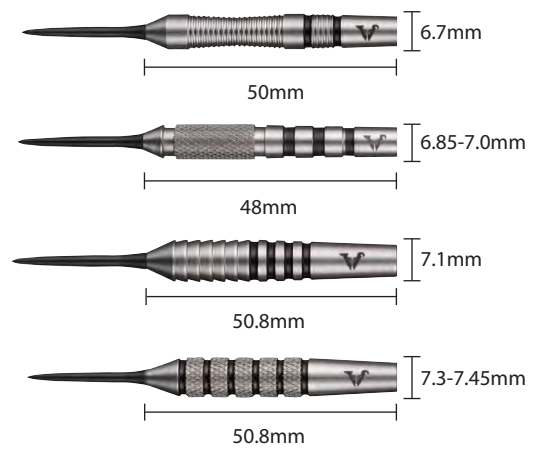

(Accessories Included)

*Blitz replacement point: 37-0107
Sold in 5 Packs, 3 Pieces per bag.



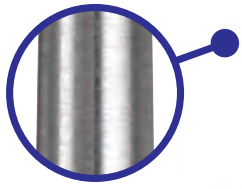

Comes in Soft Tip
Page 10

Dart Cases
Page 86

VIPER UPDATED DESIGN
SINISTER

STEEL TIP

The Sinister features an ultra smooth 95% Tungsten barrel. Precision machined for perfect balance. Comes with heavy-duty 100 micron thick flights.

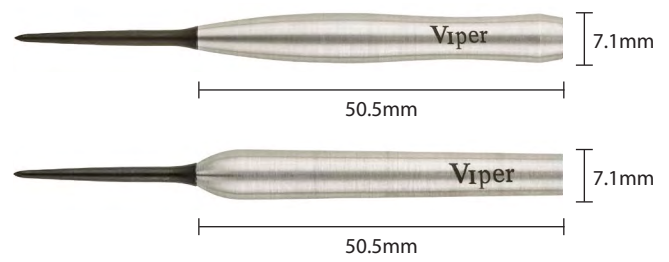

- BARRELS** 3 95% Tungsten
- SHAFTS** 3 Aluminum with locking hole
- SPARE SHAFTS** 3 Convex nylon
- FLIGHTS** 6 V-100
- POINTS** Oxide coated steel
- WEIGHT** Last two digits denote weight (Item #: XX-XXXX-XX)
- PACKAGE** Display box
- TOOL** Dart mechanic wrench
- WARRANTY** Lifetime barrel warranty

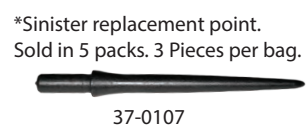



23-1602-24



23-1603-24

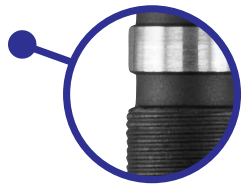

Comes in Soft Tip
Page 6



VIPER[®] DESPERADO

STEEL TIP

The Viper[®] Desperado darts have a slim barrel design makes for tight groupings with a light knurling grip for a controlled release.

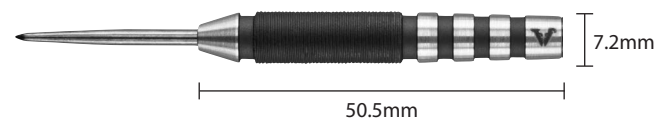

- BARRELS** 3 80% Tungsten
- SHAFTS** 3 Aluminum with locking hole
- SPARE SHAFTS** 6 Viperlock Clear
- FLIGHTS** 3 V-Lux Fantail
- SPARE FLIGHTS** 3 Wide glide
- POINTS** Tempered steel
- WEIGHT** 24 Grams
- CASE** Viper[®] TacTech
- TOOL** Dart mechanic wrench
- WARRANTY** Lifetime barrel warranty



(Accessories Included)

VIPER[®] BULLY

STEEL TIP 23-1904-24

The fierce Viper[®] Bully darts feature 80% tungsten barrels with deep knurling for a controlled throw. Packaged in the timeless Deluxe Dart Pal[®] with plenty of room for backup supplies and accessories in a convenient, compact size.

- BARRELS** 3 80% Tungsten, cross-cut knurled
- SHAFTS** 3 Aluminum Color Master with locking hole
- SPARE SHAFTS** 3 Convex nylon
- FLIGHTS** 3 V-Lux, 3 Wide glide
- POINTS** Tempered steel
- WEIGHT** 24 Grams
- CASE** Deluxe Dart Pal[®]
- TOOL** Dart mechanic wrench
- KIT** 3 Flight protectors
- WARRANTY** Lifetime barrel warranty



LOCKING HOLE

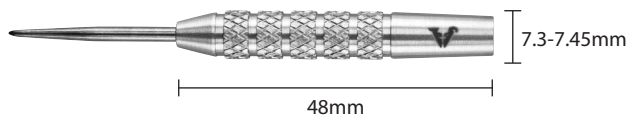

(Accessories Included)

VIPER[®] V-FACTOR

STEEL TIP

Take your game from casual to pro with the Viper[®] V-Factor steel tip darts designed for use with sisal dart boards. V-Factor darts are forged from 90% tungsten and are equipped with 150 micron thick flights giving you the slimmest barrel and longest lasting flights.

- BARRELS** 3 90% Tungsten, CNC machined
- SHAFTS** 3 Aluminum with locking hole
- SPARE SHAFTS** 3 Convex nylon
- POINTS** Tempered steel
- FLIGHTS** 3 V-150
- SPARE FLIGHTS** 3 Wide glide
- WEIGHT** Last two digits denote weight (Item #: XX-XXXX-XX)
- CASE** Deluxe Dart Pal[®]
- KIT** 3 Flight protectors
- TOOL** Dart mechanic wrench
- WARRANTY** Lifetime barrel warranty



LOCKING HOLE

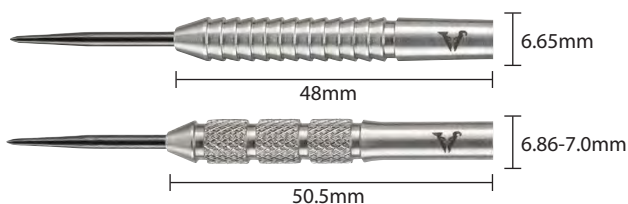

23-1702-22

23-1704-24



(Accessories Included)



LOCKING HOLE



23-2821-21



23-2823-23

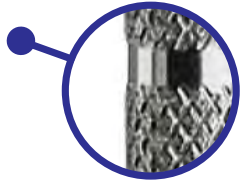

JACKAL™



STEEL TIP

Take care of business with the innovative Jackal™ darts. Unique styling includes an aluminum shaft with fine knurled bands on the 80% tungsten barrel. The beginner player will appreciate the no-frills, no-fuss styling of this great starter dart.

- BARRELS** 3 80% Tungsten, fine knurled
- SHAFTS** 3 Aluminum with locking hole
- FLIGHTS** 3 V-Lux
- POINTS** Tempered steel
- WEIGHT** Last two digits denote weight (Item #: XX-XXXX-XX)
- CASE** Dart wallet
- WARRANTY** Lifetime barrel warranty

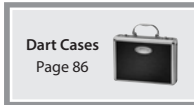
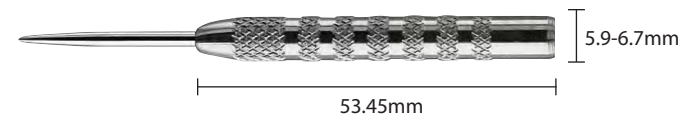
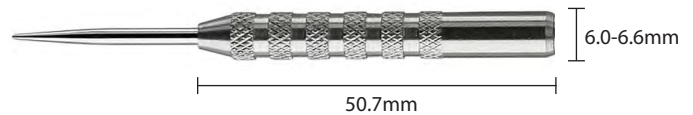

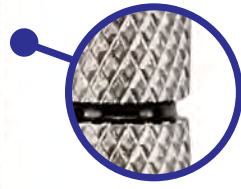

Dart Cases
Page 86

VIPER UPDATED DESIGN
COLD STEEL

STEEL TIP

The Viper® Cold Steel dart is sure to bring you new respect in the dart league! Designed and built with the competitor in mind, Cold Steel will give you the predatory instinct you need to make your mark. Features knurling for expert grip and hand painted decorative rings.

**80%
TUNGSTEN**

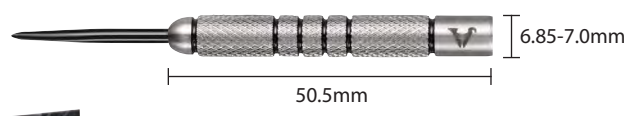
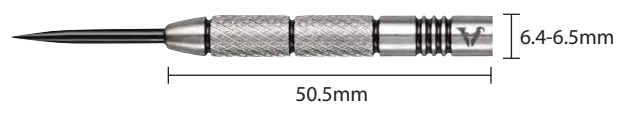

- BARRELS** 3 80% Tungsten, grooved and knurled
- SHAFTS** 3 Aluminum Color Master with locking hole
- SPARE SHAFTS** 3 Convex nylon
- FLIGHTS** 3 V-100, 3 Wide glide
- POINTS** Oxide coated steel
- WEIGHT** Last two digits denote weight
(Item #: XX-XXXX-XX)
- PACKAGE** Display box
- TOOL** Dart mechanic wrench
- WARRANTY** Lifetime barrel warranty



(Accessories Included)



LOCKING HOLE



23-1801-21



23-1803-23



23-1802-25

Comes in Soft Tip
Page 14

Dart Cases
Page 86

VIPER UPDATED DESIGN

SIDEWINDER

STEEL TIP

Strike your foes with the merciless force of nature's fiercest predator. The Sidewinder darts will invoke fear in the hearts of your opponents, allowing you to take the advantage. Three different grip styles allow you to choose your weapon wisely.

80% TUNGSTEN

- BARRELS** 3 80% Tungsten
- SHAFTS** 3 Aluminum with locking hole
- SPARE SHAFTS** 3 Convex nylon
- FLIGHTS** 6 V-100
- POINTS** Oxide coated steel
- WEIGHT** Last two digits denote weight (Item #: XX-XXXX-XX)
- PACKAGE** Display box
- TOOL** Dart mechanic wrench
- WARRANTY** Lifetime barrel warranty



(Accessories Included)



DART DIVA
22-1903-22



DART BITCH
22-1904-22



 Comes in Soft Tip
Page 17

 Replacement Flights
Page 75

VIPER VANITY

STEEL TIP

Let your personality show in your dart game. Bring your unique attitude with the Viper® Vanity steel tip darts designed for use with sisal dart boards. These darts are packed with features starting with the barrel, fashioned with specially coated alloy. The barrels feature audacious graphics, with your choice of style to match your personality.

- BARRELS** 3 Coated alloy with hand painted rings and metallic printed dart logos
- SHAFTS** 3 Aluminum with locking hole
- SPARE SHAFTS** 3 Convex nylon
- FLIGHTS** 6 V-100
- POINTS** Oxide coated steel
- WEIGHT** 22 Grams
- CASE** Special Edition Deluxe Dart Pal®
- TOOL** Dart mechanic wrench
- KIT** 3 Flight protectors
- WARRANTY** Lifetime barrel warranty



(Accessories Included)



Comes in Soft Tip
Page 19

Replacement Shafts
Page 82

Dart Cases
Page 86

VIPER UPDATED DESIGN

THE FREAK

STEEL TIP

The Freak comes with Yukon Spinsters™ shafts and a unique nickel silver knurled barrel, sure to leave an impression on anyone who sees this in your arsenal. The shaft top rotates to allow the flight to spin, preventing the deflection of an incoming dart.

- BARREL** 3 Nickel silver with hand painted rings and grooves
- SHAFTS** 3 Yukon Spinsters™ with locking hole
- SPARE SHAFTS** 3 Viperlock
- FLIGHTS** 6 V-100
- POINTS** Oxide coated steel
- WEIGHT** 22 Grams
- PACKAGE** Display box
- TOOL** Dart mechanic wrench
- WARRANTY** Lifetime barrel warranty



(Accessories Included)

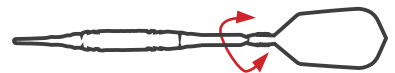

ALUMINUM SPINSTER™ SHAFT ALLOWS THE FLIGHT TO MOVE OUT OF THE WAY FOR LESS DEFLECTION.



CELTIC BLOOD
22-2322-22

ROCK & ROLL
22-2323-23

FATAL SHOT
22-2324-24

RAVEN
22-2325-25

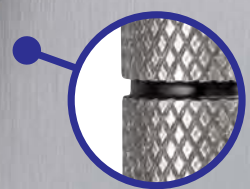

22-2324-24 22-2325-25 22-2323-23 22-2322-22

 Comes in Soft Tip
Page 24

 Dart Cases
Page 86



LOCKING HOLE

VIPER UNDERGROUND

STEEL TIP

Underground darts are packed with features starting with the barrel, fashioned from Tungsteel alloy. Constructing the darts in this fashion allows us to bring you tough, weighted barrels without breaking the bank.

- BARRELS** 3 Tungsteel alloy, center balanced
- SHAFTS** 3 Aluminum with locking hole
- SPARE SHAFTS** 3 Convex nylon
- FLIGHTS** 6 V-Lux
- POINTS** Oxide coated steel
- WEIGHT** Last two digits denote weight (Item #: XX-XXXX-XX)
- PACKAGE** Display box
- TOOL** Dart mechanic wrench
- WARRANTY** Lifetime barrel warranty



(Accessories Included)

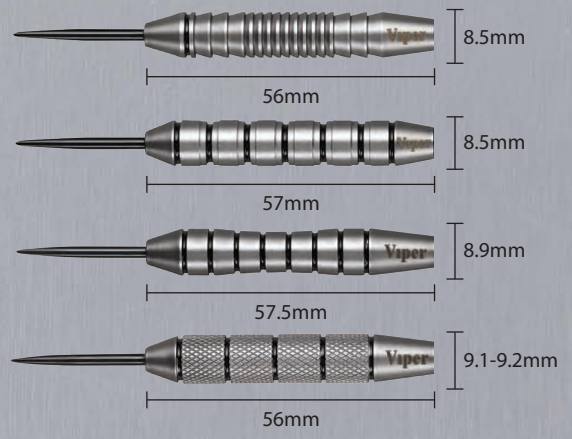



22-1501-22



22-1502-22



22-1503-22



LOCKING HOLE

Comes in Soft Tip
Page 22



Dart Cases
Page 86



VIPER COMIX

STEEL TIP

Viper® creates darts with an insider's knowledge of what the darters need. The Comix series has been designed with smartly situated grooves on brightly colored barrels. They are balanced and weighted, making you the slick super hero you want to be. Comes with a matching set of flights.

- BARRELS** 3 Coated alloy with pineapple cut grooves
- SHAFTS** 3 Aluminum with locking hole
- SPARE SHAFTS** 3 Convex nylon
- FLIGHTS** 6 Wide glide
- POINTS** Tempered steel
- WEIGHT** 22 Grams
- PACKAGE** Display box
- TOOL** Dart mechanic wrench
- WARRANTY** Lifetime barrel warranty

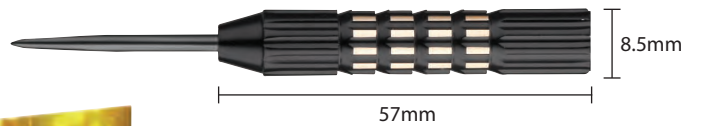

22-1502-22



22-1503-22



22-1501-22



(Accessories Included)



22-0522-22



22-0523-23



22-0524-24



22-0525-25



Comes in Soft Tip
Page 26



Dart Cases
Page 86



VIPER[®] SILVER THUNDER

STEEL TIP

Viper[®] Silver Thunder darts are ready to rain on any dartboard and are offered in high quality nickel silver plated barrels. Its exceptional balance and styling makes it one of our most popular models. Features hand painted rings and intricate knurling for extra control.

- BARRELS** 3 Nickel silver plated with hand painted rings, shark tooth grooves
- SHAFTS** 3 Convex nylon
- FLIGHTS** 3 V-Lux
- POINTS** Tempered steel
- WEIGHT** Last two digits denotes weight (Item #: XX-XXXX-XX)
- PACKAGE** Hangsell
- WARRANTY** Lifetime barrel warranty

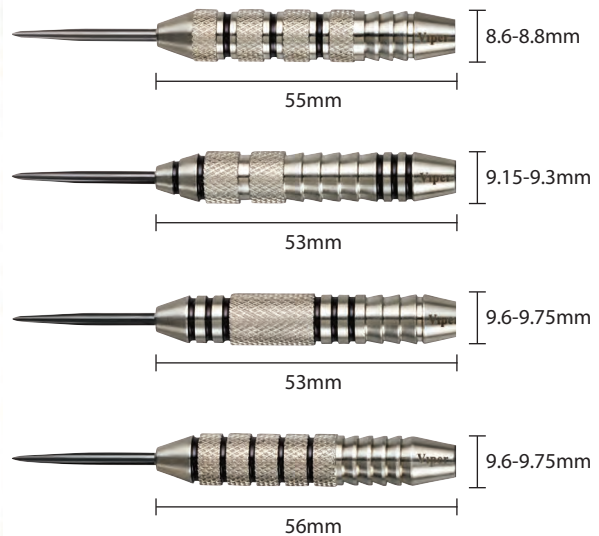



22-0623-23



22-0624-24



22-0625-25

Comes in Soft Tip
Page 27



Dart Cases
Page 86



VIPER UPDATED DESIGN

ELITE BRASS

STEEL TIP

Begin your journey into the game of darts with this high quality brass model. The Elite Brass is an excellent way to experiment with style and weight before committing to a set for more experienced players. Choose either knurled or smooth, both featuring hand painted rings.

- BARRELS** 3 Brass with hand painted rings
- SHAFTS** 3 Viperlock
- FLIGHTS** 3 V-Lux
- POINTS** Tempered steel
- WEIGHT** Last two digits denote weight (Item #: XX-XXXX-XX)
- PACKAGE** Hangsell
- WARRANTY** Lifetime barrel warranty

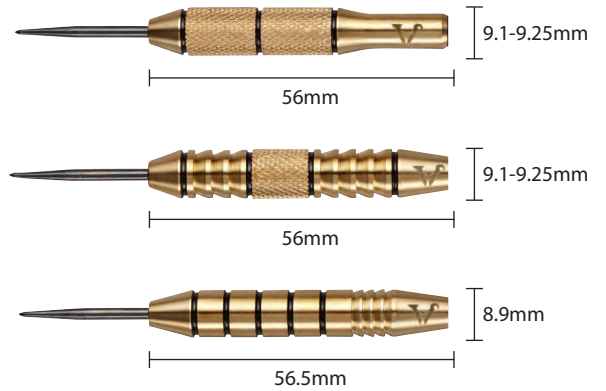

VIPER

BLACK MARIAH

STEEL TIP **22-1322-22**

Black Mariah darts are packed with features starting with the barrel, fashioned from a specially coated alloy. Constructing the barrels in this fashion allows us to bring you tough, weighted darts without breaking the bank.

- BARRELS** 3 Black coated alloy, knurled and ridged
- SHAFTS** 3 Aluminum with locking hole
- FLIGHTS** 3 V-Lux
- POINTS** Oxide coated steel
- WEIGHT** 22 Grams
- PACKAGE** Hangsell
- WARRANTY** Lifetime barrel warranty

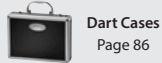

Dart Cases
Page 86

VIPER

COMMERCIAL BAR DART

STEEL TIP **37-1330**

Steel Commercial Bar Darts are economical and durable with one-piece molded flights and steel barrels.

- BARRELS** Knurled coated steel
- SHAFTS** 1-Piece molded 1/4" thread resin flight and shaft
- POINTS** Tempered steel
- WEIGHT** 17 Grams
- PACKAGE** Display box
- WARRANTY** Limited 90 day

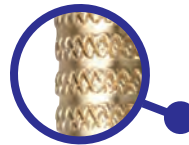

REPLACEMENT FLIGHTS

COLORS **100 per bag**

1-piece molded 1/4" thread resin flight and shaft

- BLACK** 34-5300-01
- RED** 34-5300-02
- BLUE** 34-5300-03
- YELLOW** 34-5300-07



ADDITIONAL BRANDS



AVAILABLE IN SOFT & STEEL TIP

The Fat Cat® brand is manufactured and distributed exclusively by GLD Products®. This brand was introduced by GLD® to appeal to the retailer looking for product packaged in such a way as to function well in a hangsell environment. In addition, the items are shipped in bulk case lots making it easier for our clients to enjoy price breaks as well as always having adequate stock of their key items. The Fat Cat® brand enjoys the high standards found in all GLD Products® and is perfect for casual players, families, and serious darters.



AVAILABLE IN SOFT & STEEL TIP

Elkadart® is a great value, British Made brand from the makers of Pentathlon and Amazon. It started with a small range in England "The Home of Darts" in the 1970s, grew throughout the 1980s, and began to flourish at the end of the 90s. It has developed into "The Brand You Can Trust", catering to players of all abilities. Never compromising on its heritage, production has remained firmly and proudly in England. Utilizing only the highest quality materials, the range is a mixture of both traditional and innovative designs which are of course always "Made in England".



AVAILABLE IN SOFT & STEEL TIP

When Horizon Darts purchased Laserdarts® in the 80s, Laserdarts® had a long-standing reputation for being the best (Black Widow™, Golden Eagles™, etc). This has not changed. The Black Widow™ is still the world's most copied dart barrel design. At Horizon, attention to detail and quality control insures that you get a product worthy of your hard earned money. Laserdarts® are once again being manufactured in the U.S. They manufacture perfectly balanced, match-weighted, military grade tungsten with scientific vapor coatings where applicable for the durability you expect in a premier product. Most models are available in soft, fixed point steel or movable point steel options, and all have Laserdart's® no hassle lifetime barrel warranty.



UPDATED DESIGN

BULLETZ

90% TUNGSTEN

SOFT TIP 26-4410 | 6 Pack

The Bulletz are made with 90% tungsten barrels, these darts are sure to give your opponent a run for their money.

- BARRELS** 3 90% Tungsten, ridge-back, center balanced
- SHAFTS** 6 Convex nylon
- FLIGHTS** 3 Poly Pro
- TIPS** 6 2BA Tufflex
- WEIGHT** 18 Grams
- CASE** Slim case
- TOOL** Dart mechanic wrench
- WARRANTY** Lifetime barrel warranty

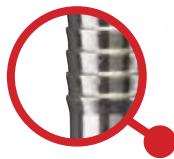

(Accessories Included)

Comes in Steel Tip
Page 54



UPDATED DESIGN

SUPPORT OUR TROOPS

SOFT TIP 20-2075-20 | 6 Pack

Fat Cat® Support Our Troops darts pay tribute to the brave soldiers that serve and protect our country. Part of the proceeds from this product will be donated to Veteran's Outreach of Wisconsin. Hand painted red, white, and blue rings adorn the barrel. Comes with matching flights.

- BARRELS** 3 Nickel silver, front weighted
- SHAFTS** 6 Convex nylon
- FLIGHTS** 6 Poly Pro
- TIPS** 9 2BA Tufflex
- WEIGHT** 20 Grams
- CASE** Special Edition Deluxe Dart Pal®
- TOOL** Dart mechanic wrench
- KIT** 3 Flight protectors
- WARRANTY** Lifetime barrel warranty



(Accessories Included)

Comes in Steel Tip
Page 56



PINK LADY

SOFT TIP 20-0625-16 | 6 pack

Support the fight against breast cancer as you throw darts to your heart's content. Fat Cat® Pink Lady darts feature hand painted rings and deep knurling for steadfast grip. Part of the proceeds from this product will be donated to Wisconsin Breast Cancer Showhouse. The special edition Pink Lady Deluxe Dart Pal® showcases a printed pink ribbon design on the dart case.

- BARRELS** 3 Nickel silver plated with hand painted rings
- SHAFTS** 3 Aluminum with locking hole
- SPARE SHAFTS** 3 Convex nylon
- FLIGHTS** 6 Poly Pro
- TIPS** 9 2BA Tufflex
- WEIGHT** 16 Grams
- CASE** Special Edition Deluxe Dart Pal®
- KIT** 3 Flight protectors
- TOOL** Dart mechanic wrench
- WARRANTY** Lifetime barrel warranty



LOCKING HOLE



(Accessories Included)



UPDATED DESIGN

DARTS IN A JAR

21 SOFT TIP DARTS 26-7010

Grab your friends, and enjoy yourself some Darts in a Jar. The Darts in a Jar includes 21 complete soft tip darts so everyone can play.

- BARRELS** Nickel silver ringed and knurled
- SHAFTS** Reinforced convex nylon
- FLIGHTS** Poly Pro
- TIPS** 2BA Tufflex
- WEIGHT** 17 Grams
- PACKAGE** Storage jar
- WARRANTY** Lifetime barrel warranty



Comes in Steel Tip
Page 54 



REALTREE APC®

SOFT TIP 26-1427 | 6 Pack

The Fat Cat® Licensed Realtree APC® dart set is the ideal camouflaged dart with a touch of bright color. Eye up the perfect shot with a largely knurled center band, maximizing grip.

- BARRELS** 3 Nickel silver, center balanced with hand painted rings
- SHAFTS** 3 Aluminum Color Master with locking hole
- SPARE SHAFTS** 3 Convex nylon
- FLIGHTS** 6 Poly Pro
- TIPS** 23 2BA Tufflex Tips
- WEIGHT** 16 Grams
- CASE** Slim case
- TOOL** Dart mechanic wrench
- WARRANTY** Lifetime barrel warranty



LOCKING HOLE



(Accessories Included)

Comes in Steel Tip
Page 55

REALTREE APC
REALTREE APC HD ©2006 of Jordan Outdoor Enterprises, Ltd. All rights reserved.



REALTREE XTRA®

SOFT TIP 26-1425 | 6 pack

With Realtree, hunting is everything, and the Realtree soft tip darts allow you to carry that mantra into even more aspects of your life. Nickel silver plated barrels are built to stand up to heavy use and highlight the signature camouflage appearance you know and love. Includes a case, extra shafts and tips, and a dart repair tool.

- BARRELS** 3 Nickel, with rubberized Sure Grip sleeve
- SHAFTS** 6 Convex nylon
- FLIGHTS** 6 Poly Pro
- TIPS** 23 2BA Tufflex Tips
- WEIGHT** 16 Grams
- CASE** Slim case
- TOOL** Dart mechanic wrench
- WARRANTY** Lifetime barrel warranty



Replacement Sure Grip sleeves available on page 25



(Accessories Included)

Comes in Steel Tip
Page 55

REALTREE XTRA
Realtree AP-XTRA Camouflage Design © 2012 of Jordan Outdoor Enterprises, Ltd., all rights reserved.



UPDATED DESIGN

BLAZER

SOFT TIP **26-1430 | 6 Pack**

Each Blazer dart set offers the ultimate in reliability. No matter if you're in your home gameroom or out and about in a league, you will be sure to stand out with this blazing dart.

- BARRELS** 3 Nickel plated steel, center balanced, knurled
- SHAFTS** 6 Convex nylon
- FLIGHTS** 6 Poly Pro
- TIPS** 6 2BA Tufflex tips
- WEIGHT** 16 Grams
- CASE** Slim case
- TOOL** Dart mechanic wrench
- WARRANTY** Lifetime barrel warranty

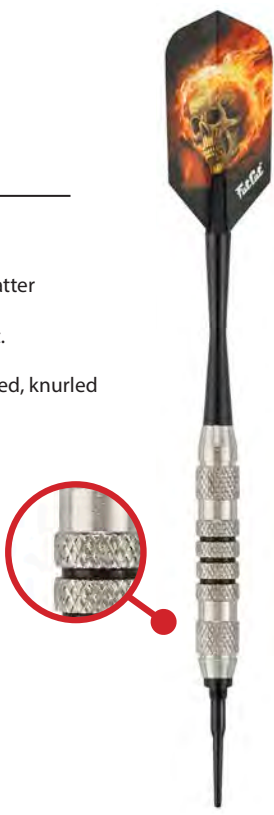

(Accessories Included)

Comes in Steel Tip
Page 57 



DELUXE

SOFT TIP **26-1420 | 6 Pack**

Take your game to the next level! When you shoot with the Deluxe darts you ensure that you're playing with the best value in darts. A special plated alloy gives these barrels a toughness sure to last through thousands of throws!

- BARRELS** 3 Plated steel
- SHAFTS** 6 Convex nylon
- FLIGHTS** 6 Poly Pro
- TIPS** 9 2BA Tufflex tips
- WEIGHT** 16 Grams
- CASE** Slim case
- TOOL** Dart mechanic wrench
- WARRANTY** Lifetime barrel warranty



(Accessories Included)

Comes in Steel Tip
Page 57 



WARRIOR

SOFT TIP **26-1410 | 6 Pack**

Embrace the spirit of a champion, and reign victorious over your foes when your weapon of choice is the Warrior! Your fighting spirit is unmatched and will be sure to crush your adversaries.

- BARRELS** 3 Knurled and grooved plated steel
- SHAFTS** 3 Convex nylon
- FLIGHTS** 3 Poly Pro
- TIPS** 3 2BA Tufflex tips
- WEIGHT** 16 Grams
- PACKAGE** Blister pack
- WARRANTY** Lifetime barrel warranty



Comes in Steel Tip
Page 58

Dart Cases
Page 86



HIGHLANDER

SOFT TIP **26-1400 | 6 Pack**

When looking for a quality bar dart to get the job done, the reliable Fat Cat® Highlander one-piece flight and shaft will be what gets you to the next round.

- BARRELS** 3 Steel, center balanced, knurled
- SHAFTS** 3 One-piece nylon flight/shaft
- TIPS** 3 2BA Tufflex tips
- WEIGHT** 16 Grams
- PACKAGE** Blister pack
- WARRANTY** Lifetime barrel warranty

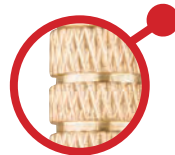

Comes in Steel Tip
Page 59



PREDATOR

STEEL TIP **26-4413 | 4 Pack**

80% Tungsten provides a tough, thin barrel for tight groupings. The Fat Cat® Predator is ready for retail peg hooks and sold in packs of four.

- BARRELS** 3 80% Tungsten, center balanced, knurled with hand painted grooves
- SHAFTS** 3 Aluminum Color Master with locking hole
- SPARE SHAFTS** 6 Convex nylon
- FLIGHTS** 6 Poly Pro
- POINTS** Oxide coated steel
- WEIGHT** 23 Grams
- CASE** Deluxe Dart Pal®
- TOOL** Dart mechanic wrench
- KIT** 3 Flight protectors
- WARRANTY** Lifetime barrel warranty

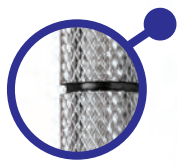

(Accessories Included)



BULLETZ

90% TUNGSTEN

STEEL TIP 26-4411 | 6 Pack

The Bulletz barrels are 90% tungsten and textured for a superior grip. Perfect for the darter looking to upgrade to Tungsten to elevate their game to a higher level.

- BARRELS** 3 90% Tungsten barrels, center balanced, grooved and knurled
- SHAFTS** 6 Convex nylon
- FLIGHTS** 3 Poly Pro
- POINTS** Oxide coated steel
- WEIGHT** 23 Grams
- CASE** Slim case with Built-in Dart Shaper
- TOOL** Dart mechanic wrench
- WARRANTY** Lifetime barrel warranty



(Accessories Included)

Comes in Soft Tip Page 48



UPDATED DESIGN

DARTS IN A JAR

STEEL TIP DARTS

- 15 COUNT 26-7022
- 21 COUNT 26-7020
- 27 COUNT 26-7021

These darts are packed with features starting with the barrel, fashioned from nickel silver alloy. Nickel silver is an alloy that has been used in construction for its durability and great looking style, while maintain a lower cost. Each barrel enjoys heavily knurled bands, allowing your grip to remain consistent throw after throw.

- BARRELS** Nickel silver, counter balanced
- SHAFTS** Reinforced convex nylon
- FLIGHTS** Poly Pro
- POINTS** Oxide coated steel
- WEIGHT** 20 Grams
- PACKAGE** Storage jar
- WARRANTY** Lifetime barrel warranty



Comes in Soft Tip Page 49



REALTREE APC®

STEEL TIP **26-1428 | 6 Pack**

This licensed Realtree APC® dart set is the ideal camouflaged dart to eye up the perfect shot while adding a subtle touch of color and style.

- BARRELS** 3 Nickel silver with hand painted rings
- SHAFTS** 3 Aluminum Color Master with locking hole
- SPARE SHAFTS** 3 Convex Nylon
- FLIGHTS** 6 Poly Pro
- POINTS** Tempered steel
- WEIGHT** 23 Grams
- CASE** Slim case
- TOOL** Dart mechanic wrench
- TOOL** Tip shaping stone
- WARRANTY** Lifetime barrel warranty



(Accessories Included)



Comes in Soft Tip Page 50 



REALTREE HARDWOODS HD®

STEEL TIP **26-1426 | 6 Pack**

Licensed Realtree Hardwoods HD® dart set is the ideal camouflaged dart to eye up the perfect shot. Enhanced by the alloy plated steel knurling, this dart is sure to hit its mark.

- BARRELS** 3 Alloy plated steel, center balanced, grooved and knurled
- SHAFTS** 6 Convex nylon
- FLIGHTS** 6 Poly Pro
- POINTS** Tempered steel
- WEIGHT** 23 Grams
- CASE** Slim case
- TOOL** Dart mechanic wrench
- TOOL** Tip shaping stone
- WARRANTY** Lifetime barrel warranty

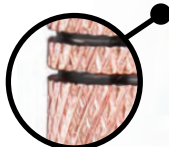
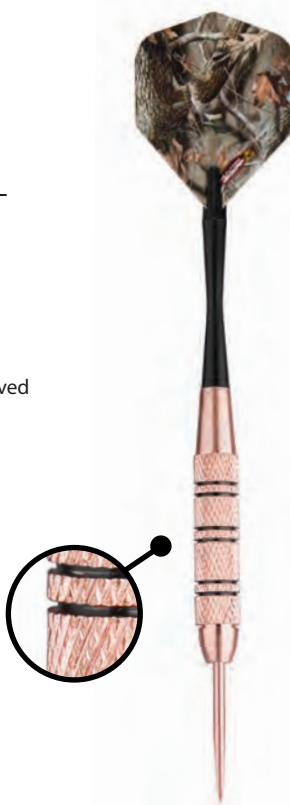

(Accessories Included)



REALTREE HARDWOODS HD ©2001 of Jordan Outdoor Enterprises, Ltd. All rights reserved.



UPDATED DESIGN

SUPPORT OUR TROOPS

STEEL TIP

22-2075-23 | 6 pack

Fat Cat® Support Our Troops darts pay tribute to the brave soldiers that serve and protect our country. Part of the proceeds from this product will be donated to Veteran's Outreach of Wisconsin. Hand painted red, white, and blue rings adorn the barrel. Comes with matching flights.

- BARRELS** 3 Nickel silver, front weighted
- SHAFTS** 9 Convex nylon
- FLIGHTS** 6 Poly Pro
- POINTS** Oxide coated steel
- WEIGHT** 23 Grams
- CASE** Special Edition Deluxe Dart Pal®
- TOOL** Dart mechanic wrench
- KIT** 3 Flight protectors
- WARRANTY** Lifetime barrel warranty



(Accessories Included)



TWIN PACK

STEEL TIP

26-7110 | 6 Pack

The Twin Pack has everything needed for a fast game between friends. These aerodynamic darts include knurled barrels for enhanced performance.

- BARRELS** 6 Tungzite, center balanced, grooved and knurled
- SHAFTS** 6 Convex nylon
- FLIGHTS** 6 Poly Pro
- POINTS** Tempered steel
- WEIGHT** 19 Grams
- WARRANTY** Lifetime barrel warranty

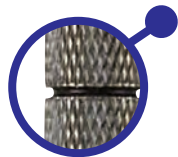

Dart Cases
Page 86



BLAZER

STEEL TIP **26-1431 | 6 Pack**

Blaze a trail to the bullseye with the Blazer. A fusion of inlaid rings with a large band of knurling creates a combo of unbeatable traction for the darter looking for a fantastic grip.

- BARREL** 3 Nickel silver, center balanced, knurled
- SHAFTS** 6 Convex nylon
- FLIGHTS** 3 Poly Pro
- POINTS** Oxide coated steel
- WEIGHT** 23 Grams
- CASE** Slim case
- TOOL** Dart mechanic wrench
- WARRANTY** Lifetime barrel warranty

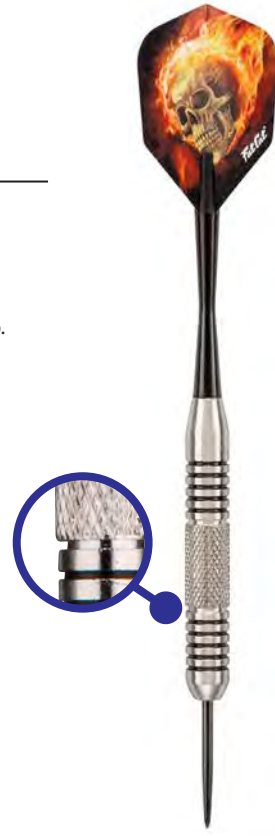

(Accessories Included)

Comes in Soft Tip
Page 51 



UPDATED DESIGN

DELUXE

STEEL TIP **26-1421 | 6 Pack**

Take your game to the next level! When you shoot with the Deluxe darts you ensure that you're playing with the best value in darts. A special plated alloy gives these barrels a toughness sure to last through thousands of throws!

- BARRELS** 3 Plated steel, concave grip, painted grooves
- SHAFTS** 6 Convex nylon
- FLIGHTS** 3 Poly Pro
- POINTS** Oxide coated steel
- WEIGHT** 23 Grams
- CASE** Slim case
- TOOL** Dart mechanic wrench
- WARRANTY** Lifetime barrel warranty

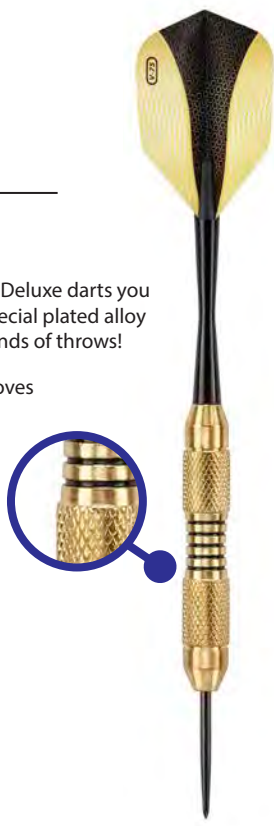

(Accessories Included)

Comes in Soft Tip
Page 51 



WARRIOR

STEEL TIP

26-1411 | 6 Pack

Embrace the spirit of a champion, and reign victorious over your foes when your weapon of choice is the Warrior! Your fighting spirit is unmatched and will be sure to crush your adversaries.

- BARRELS** 3 Plated steel, center balanced
- SHAFTS** 3 Convex nylon
- FLIGHTS** 3 Poly Pro
- WEIGHT** 18 Grams
- PACKAGE** Hangsell
- WARRANTY** Lifetime barrel warranty



Dart Cases
Page 86



Comes in
Soft Tip
Page 52



BEER DARTS

STEEL TIP

26-1490 | 6 Pack

Drink and be merry with the Fat Cat Beer Darts Steel Tip Darts designed with Amber plated alloy barrels. Each barrel features heavily knurled bands, allowing your grip to remain consistent throw after throw. Each dart is finished off with the refreshingly smooth lager graphics adorning each flight.

- BARRELS** 3 Steel, center balanced, knurled
- SHAFTS** 3 Convex nylon
- FLIGHTS** 3 Poly Pro
- POINTS** Oxide coated steel
- WEIGHT** 17 Grams
- PACKAGE** Hangsell
- WARRANTY** Lifetime barrel warranty



Dart Cases
Page 86





HIGHLANDER

STEEL TIP

26-1401 | 6 Pack

When looking for a quality bar dart to get the job done, the reliable Fat Cat® Highlander one-piece flight and shaft will be what gets you to the next round.

- BARRELS** 3 Plated steel, center balanced, knurled
- SHAFTS/FLIGHTS** 3 One-piece molded flight/shaft
- POINTS** Oxide coated steel
- WEIGHT** 23 Grams
- PACKAGE** Hangsell
- WARRANTY** Lifetime barrel warranty



Dart Cases
Page 86 

Comes in
Soft Tip
Page 52 

FAT CAT® DART ACCESSORIES

MUST ORDER IN PACK QUANTITIES



DART POINT SHAPER | 37-0101
1 piece per card | 12 pack



ALUMINUM SHAFTS | 28-7210
3 pieces per card | 12 pack



2BA DART WASHERS | 28-1400
18 pieces per card | 12 pack



2BA TUFFLEX II
37-1615-01K | 150 ct. | 12 pack
2BA TUFFLEX II
37-1604-01F | 50 ct. | 12 pack



TIP REMOVER | 37-0050
1 piece per card | 6 pack
Easily removes broken plastic tips from dartboard



ASSORTED FLIGHTS | 28-7240
30 pieces per card | 12 pack assorted
10 matching sets per card, 30 flights total per card

ELKADART

Trademarks used with permission and are owned by Elkadart.
MADE IN ENGLAND.

ELKADART

RAINBOW

SOFT TIP

The Rainbow's ridge-back knurling styles provide excellent gripping points.

- BARRELS** 3 90% Tungsten, titanium coated
- SHAFTS** 3 Aluminum with locking hole
- FLIGHTS** 3 Custom 100 micron
- TIPS** 3 2BA
- WEIGHT** Last two digits denote weight (Item #: XX-XXXX-XX)
- CASE** Slim case
- WARRANTY** Limited 90 day



LOCKING HOLE



21-3153-16



21-3153-18



21-3154-18

21-3153-18

ELKADART

TORNADO

SOFT TIP

The Tornado dart set features a range to suit the most competitive players.

- BARRELS** 3 90% Tungsten
- SHAFTS** 3 Regrooved aluminum with locking hole
- FLIGHTS** 3 Custom 100 micron
- TIPS** 3 2BA
- WEIGHT** Last two digits denote weight (Item #: XX-XXXX-XX)
- CASE** Slim case
- WARRANTY** Limited 90 day



LOCKING HOLE



21-2281-16



21-2281-18



21-2276-16



21-2276-18

21-2276-18

Trademarks used with permission and are owned by Elkadart.
MADE IN ENGLAND.



TITANIUM

SOFT TIP



LOCKING HOLE



Polish your game with the Elkadart® Titanium darts. The 90% tungsten barrels have a slim profile, allowing for tighter grouping of shots which increase scoring. Knurled barrel with grooves and rings provides an excellent and consistent grip throw after throw.

- BARRELS** 3 90% Tungsten
- SHAFTS** 3 Skimmed aluminum with locking hole
- FLIGHTS** 3 Custom 100 micron
- TIPS** 3 2BA
- WEIGHT** Last two digits denote weight (Item #: XX-XXXX-XX)
- CASE** Slim case
- WARRANTY** Limited 90 day



21-3203-16



21-3203-18



21-3204-18

21-3203-16



ULTRA SONIC

SOFT TIP



LOCKING HOLE



A top of the range English designed tungsten dart, manufactured using high end Elkadart® technology. These unusual and distinctive designs are very desirable with firm holding grips.

- BARRELS** 3 80% Tungsten
- SHAFTS** 3 Regrooved aluminum with locking hole
- FLIGHTS** 3 Custom 100 micron
- TIPS** 3 2BA
- WEIGHT** Last two digits denote weight (Item #: XX-XXXX-XX)
- CASE** Slim case
- WARRANTY** Limited 90 day



21-2807-16



21-2808-18

21-2807-16

Trademarks used with permission and are owned by Elkadart®.
MADE IN ENGLAND.



BLACK MAMBA



SOFT TIP

Black Mamba tungsten darts strike with extreme speed and precision.

- BARRELS** 3 80% Tungsten
- SHAFTS** Skimmed aluminum with locking hole
- FLIGHTS** 3 Custom 100 micron
- TIPS** 3 2BA
- WEIGHT** Last two digits denote weight (Item #: XX-XXXX-XX)
- CASE** Slim case
- WARRANTY** Limited 90 day



LOCKING HOLE



21-1900-14



21-1900-14



21-1900-16



21-1900-18



RAZOR



SOFT TIP

Slice through the air with these aerodynamic Razor tungsten darts.

- BARRELS** 3 80% Tungsten
- SHAFTS** 3 Aluminum with locking hole
- FLIGHTS** 3 Custom 100 micron
- TIPS** 3 2BA
- WEIGHT** Last two digits denote weight (Item #: XX-XXXX-XX)
- CASE** Slim case
- WARRANTY** Limited 90 day



LOCKING HOLE



21-2326-18



21-2326-16



21-2326-18



21-2329-18

Trademarks used with permission and are owned by Elkadart®.
MADE IN ENGLAND.



WIZARD



80%
TUNGSTEN

SOFT TIP

Delve into magical secrets and unleash your overwhelming power with the brand new Wizard darts from Elkadart®. These intense barrels allow you to command the arcane might and channel it into your dart game. Tungsten is the most powerful material used to make darts and you can feel the energy coursing through you.

- BARRELS** 3 80% Tungsten
- SHAFTS** 3 Aluminum with locking hole
- FLIGHTS** 3 Custom 100 micron
- TIPS** 3 2BA
- WEIGHT** Last two digits denote weight (Item #: XX-XXXX-XX)
- CASE** Slim case
- WARRANTY** Limited 90 day



21-3806-16



21-3806-18



21-3807-16



21-3807-18

21-3806-18



LONE WOLF



SOFT TIP

Unleash your primal ferocity with the brand new Lone Wolf darts. These fierce barrels are sure to bring out the animal in your game. A black coating on the nickel silver complements the knurling and rings for a precise grip.

- BARRELS** 3 Nickel silver
- SHAFTS** 3 Regrooved aluminum with locking hole
- FLIGHTS** 3 Custom 100 micron
- TIPS** 3 2BA
- WEIGHT** Last two digits denote weight (Item #: XX-XXXX-XX)
- CASE** Slim case
- WARRANTY** Limited 90 day



20-1104-14



20-1104-16



20-1104-18

20-1104-14

Trademarks used with permission and are owned by Elkadart®.
MADE IN ENGLAND.



NEON



SOFT TIP

Stand out from the crowd with this range of colorful darts. The color coated barrels with matching shafts are a favorite with all.

- BARRELS** 3 Alloy color coated
- SHAFTS** 3 Colored aluminum with locking hole
- FLIGHTS** 3 Custom 100 micron
- TIPS** 3 2BA
- WEIGHT** Last two digits denote weight (Item #: XX-XXXX-XX)
- CASE** Slim case
- WARRANTY** Limited 90 day



20-3601-18



20-3603-18



20-3604-18



20-3605-18



LOCKING HOLE



20-3603-18



ORBITAL



SOFT TIP

These top quality alloy barrels are coated with a bronze chrome finish giving them a professional look.

- BARRELS** 3 Coated alloy
- SHAFTS** 3 Aluminum with locking hole
- FLIGHTS** 3 Custom 100 micron
- TIPS** 3 2BA
- WEIGHT** Last two digits denote weight (Item #: XX-XXXX-XX)
- CASE** Slim case
- WARRANTY** Limited 90 day



20-0682-16



20-0682-18



LOCKING HOLE



20-0682-16





Trademarks used with permission and are owned by Elkadart®.
MADE IN ENGLAND.



STORM



SOFT TIP

Color ringed alloy Storm darts are available in a variety of weights and colors.

- BARRELS** 3 Alloy
- SHAFTS** 3 Aluminum with locking hole
- FLIGHTS** 3 Custom 100 micron
- TIPS** 3 2BA
- WEIGHT** Last two digits denote weight (Item #: XX-XXXX-XX)
- CASE** Slim case
- WARRANTY** Limited 90 day



20-1180-15



20-1183-16



20-1181-14



20-1184-18



20-1182-17



LOCKING HOLE



20-1183-16



TURBO



SOFT TIP

These alloy barrels are tin plated showing a satin finish that gives the look of a high quality dart barrel.

- BARRELS** 3 Alloy
- SHAFTS** 3 Aluminum with locking hole
- FLIGHTS** 3 Custom 100 micron
- TIPS** 3 2BA
- WEIGHT** Last two digits denote weight (Item #: XX-XXXX-XX)
- CASE** Slim case
- WARRANTY** Limited 90 day



20-5301-18



20-5304-12



20-5302-16



20-5305-10



20-5303-14

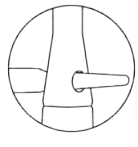

LOCKING HOLE



20-5303-14



Trademarks used with permission and are owned by Elkadart®.
MADE IN ENGLAND.



BLACK MAMBA



STEEL TIP

This sleek top of the range dart with its black coating and facets is the dart with a bite.

- BARRELS** 3 80% Tungsten
- SHAFTS** 3 Skimmed aluminum with locking hole
- FLIGHTS** 3 Custom 100 micron
- POINTS** Oxide coated steel
- WEIGHT** Last two digits denote weight (Item #: XX-XXXX-XX)
- CASE** Slim case
- WARRANTY** Limited 90 day



LOCKING HOLE



23-1420-20



23-1422-22



23-1424-24



23-1426-26



23-1426-26



RAINBOW



STEEL TIP

Tungsten Rainbow darts feature stunning multi-color coatings, no one barrel coating is the same.

- BARRELS** 3 90% Tungsten, titanium coated
- SHAFTS** 3 Aluminum with locking hole
- FLIGHTS** 3 Custom 100 micron
- POINTS** Oxide coated steel
- WEIGHT** Last two digits denote weight (Item #: XX-XXXX-XX)
- CASE** Slim case
- WARRANTY** Limited 90 day



LOCKING HOLE



23-3820-23



23-3820-25



23-3820-23



Trademarks used with permission and are owned by Elkadart®.
MADE IN ENGLAND.



RHINO



STEEL TIP

This heavy duty range of tungsten darts is designed specifically for players who demand darts of substance.

- BARRELS** 3 80% Tungsten
- SHAFTS** 3 Nylon with stem ring
- FLIGHTS** 3 Custom 100 micron
- POINTS** Oxide coated steel
- WEIGHT** Last two digits denote weight (Item #: XX-XXXX-XX)
- CASE** Slim case
- WARRANTY** Limited 90 day



23-3001-25



23-3002-26



23-3003-27



23-3004-28



23-3006-30

23-3003-27



RAZOR



STEEL TIP

An 80% tungsten dart with a special groove pattern that allows extra grip in the direction of throw.

- BARRELS** 3 80% Tungsten
- SHAFTS** 3 Aluminum with locking hole
- FLIGHTS** 3 Custom 100 micron
- POINTS** Oxide coated steel
- WEIGHT** Last two digits denote weight (Item #: XX-XXXX-XX)
- CASE** Slim case
- WARRANTY** Limited 90 day



LOCKING HOLE



23-3423-23



23-3428-21



23-3429-25

23-3429-25

Trademarks used with permission and are owned by Elkadart®.
MADE IN ENGLAND.



ULTRA SONIC



STEEL TIP

A top of the line English designed tungsten dart manufactured using Elkadart's® high end technology. These unique and distinctive designs are very desirable with firm holding grips.

- BARRELS** 3 80% Tungsten
- SHAFTS** 3 Regrooved aluminum with locking hole
- FLIGHTS** 3 Custom 100 micron
- POINTS** Oxide coated steel
- WEIGHT** Last two digits denote weight (Item #: XX-XXXX-XX)
- CASE** Slim case
- WARRANTY** Limited 90 day

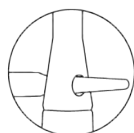

LOCKING HOLE



23-1506-23



23-1505-21



23-1506-23



23-1507-25



WIZARD



STEEL TIP

Delve into magical secrets and unleash your overwhelming power with the brand new Wizard darts from Elkadart®. These intense barrels allow you to command the arcane might and channel it into your dart game. Tungsten is the most powerful material used to make darts and you can feel the energy coursing through you.

- BARRELS** 3 80% Tungsten
- SHAFTS** 3 Aluminum with locking hole
- FLIGHTS** 3 Custom 100 micron
- POINTS** Oxide coated steel
- WEIGHT** Last two digits denote weight (Item #: XX-XXXX-XX)
- CASE** Slim case
- WARRANTY** Limited 90 day



LOCKING HOLE



23-3061-23



23-3057-19



23-3058-20



23-3059-21



23-3060-22



23-3061-23



23-3062-24

Trademarks used with permission and are owned by Elkadart®.
MADE IN ENGLAND.



LONE WOLF



STEEL TIP

Unleash your primal ferocity with the Lone Wolf darts. These fierce barrels are sure to bring out the animal in your game. A black coating on the nickel silver complements the knurling and rings for a precise grip.

- BARRELS** 3 Nickel silver
- SHAFTS** 3 Regrooved aluminum with locking hole
- FLIGHTS** 3 Custom 100 micron
- POINTS** Oxide coated steel
- WEIGHT** Last two digits denote weight (Item #: XX-XXXX-XX)
- CASE** Slim case
- WARRANTY** Limited 90 day



22-0430-19



22-0430-21



22-0430-23



LOCKING HOLE



22-0430-19



BLACK ONE FIFTY



STEEL TIP

Black One Fifty darts are comprised of premium alloy with a jet black coating.

- BARRELS** 3 Black coated alloy
- SHAFTS** 3 North Star aluminum with locking hole
- FLIGHTS** 3 Custom 100 micron
- POINTS** Oxide coated steel
- WEIGHT** Last two digits denote weight (Item #: XX-XXXX-XX)
- CASE** Slim case
- WARRANTY** Limited 90 day



22-0127-20



22-0127-24



22-0128-22



LOCKING HOLE



22-0128-22



Trademarks used with permission and are owned by Elkadart®.
MADE IN ENGLAND.



ORBITAL



STEEL TIP

These top quality alloy barrels are coated with a bronze chrome finish giving them a professional look.

- BARRELS** 3 Bronze chromed brass
- SHAFTS** 3 Aluminum with locking hole
- FLIGHTS** 3 Custom 100 micron
- POINTS** Oxide coated steel
- WEIGHT** Last two digits denote weight (Item #: XX-XXXX-XX)
- CASE** Slim case
- WARRANTY** Limited 90 day



22-0719-19



22-0721-21



22-0724-24



22-0725-22

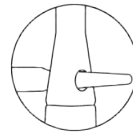

LOCKING HOLE



22-0719-19



PRISM



STEEL TIP

Prism nickel silver darts come in a variety of classic designs and features a wide range of barrel styles of knurling, rings, and grooves.

- BARRELS** 3 Nickel silver
- SHAFTS** 3 Aluminum with locking hole
- FLIGHTS** 3 Custom 100 micron
- POINTS** Oxide coated steel
- WEIGHT** Last two digits denote weight (Item #: XX-XXXX-XX)
- CASE** Slim case
- WARRANTY** Limited 90 day



22-0200-20



22-0201-21



22-0202-22



22-0203-23



22-0204-24



LOCKING HOLE



22-0203-23



Trademarks used with permission and are owned by Horizon Darts.



BLACK WIDOWS™



SOFT TIP

Black Widows™ feature a slightly front-weighted dart for increased accuracy and a slimmer barrel for more precise groups. Choose from knurled or smooth styled barrels.

- BARRELS** 3 90% Tungsten black coated knurled or smooth
- SHAFTS** 3 One piece molded flight/shaft
- TIPS** 3 2BA
- WEIGHT** Last two digits denote weight (Item #: XX-XXXX-XX)
- CASE** Styles vary



SMOOTH
EBW-1-16
EBW-1-18
EBW-1-20

KNURLED
EBW-2-16
EBW-2-18
EBW-2-20

Extra Flight Shafts Available
Page 78 



GOLD WIDOWS™



SOFT TIP

Nothing matches the attitude of the Gold Widows™. Vapor coated barrels give these darts their gold luster, while featuring slightly front-weighted construction for increased accuracy and a slimmer barrel for more precise groups. Choose from knurled or smooth styled barrels.

- BARRELS** 3 90% vapor coated Tungsten knurled or smooth
- SHAFTS** 3 One-piece molded flight/shaft
- TIPS** 3 2BA
- WEIGHT** Last two digits denote weight (Item #: XX-XXXX-XX)
- CASE** Styles vary



SMOOTH
EGW-1-18

KNURLED
EGW-2-16
EGW-2-18
EGW-2-20



SILVER WIDOWS™



SOFT TIP

The Silver Widows™ match the quality of the Black Widows™ and Gold Widows™ with an uncoated barrel, that gives these darts a friction-free release. This is a slightly front-weighted dart for increased accuracy with a slim barrel for more precise groups. Choose from knurled or smooth styled barrels.

- BARRELS** 3 90% Tungsten knurled or smooth
- SHAFTS** 3 one piece molded flight/shaft
- TIPS** 3 2BA
- WEIGHT** Last two digits denote weight (Item #: XX-XXXX-XX)
- CASE** Styles vary



SMOOTH
ESW-1-16
ESW-1-18
ESW-1-20

KNURLED
ESW-2-16
ESW-2-18
ESW-2-20



BLACK WIDOWS™



STEEL TIP

The Black Widow™ features a rough black oxide coating, slightly front-weighted dart, and a slim barrel for increased accuracy.

- BARRELS** 3 90% Tungsten Knurled or Smooth
- SHAFTS** 3 Movable - Two Piece Flight and Shaft System
3 Fixed - Spider Leg Aluminum
- FLIGHTS** 3 Style may vary
- POINTS** Tempered steel
- WEIGHT** Last two digits denote weight (Item #: XX-XXXX-XX)
- CASE** Styles vary



SMOOTH Fixed Points
BWF-1-20
BWF-1-23
BWF-1-26

KNURLED Fixed Points
BWF-2-20
BWF-2-23
BWF-2-26
BWF-2-28

SMOOTH Fixed Points
BWM-1-22
BWM-1-25

KNURLED Fixed Points
BWM-2-22
BWM-2-25

DART ACCESSORIES



FLIGHTS

Flights are available in a variety of shapes, sizes, and designs. A player's speed of throw should determine what style of flight will work best. Experiment with different flight shapes until you find the one that works best for you. Consider slim for soft-tip which are the lighter weighted darts.



SHAFTS

The shaft provides the proper spacing between the flight and the barrel. Shafts are manufactured from a number of different materials (including nylon, aluminum and polycarbonate) in varying lengths. Choose a shaft which allows a comfortable feel and a smooth, flight trajectory. To minimize "wobble" or "cork-screwing," select the shortest shaft that is comfortable for you.



TIPS

There are two types of dart tips — **steel** or **soft**. Steel-tipped darts are used with traditional English Sisal dartboards and soft-tipped darts are used with today's electronic games and plastic dartboards.



MECHANIC WRENCHES

Dart mechanic wrenches tighten tips and metal shafts. They also reshape and spread the metal shafts for easy flight insertion.

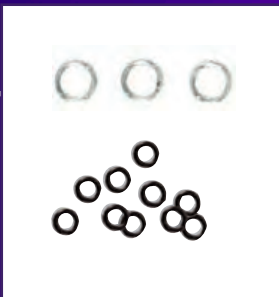

RINGS

O-rings prevent aluminum shaft separation from the dart barrel and stem rings keep the shaft prongs tight against the flight reducing the chances of the flight separating from the shaft, eliminating rattle.

 **ANATOMY**
DART ACCESSORIES

NEW PRODUCT

COOL MOLDED FLIGHTS

400 Microns Thick, 90° Angle

Sold in 5 packs, 3 flights per pack
3 Viperlock O-Rings per pack



NEW PRODUCT

AMERICAN FLAG

75 or 100 Microns Thick

Sold in 5 packs, 3 flights per bag



NEW PRODUCT

V-150

150 Microns Thick

Sold in 5 packs, 3 flights per bag

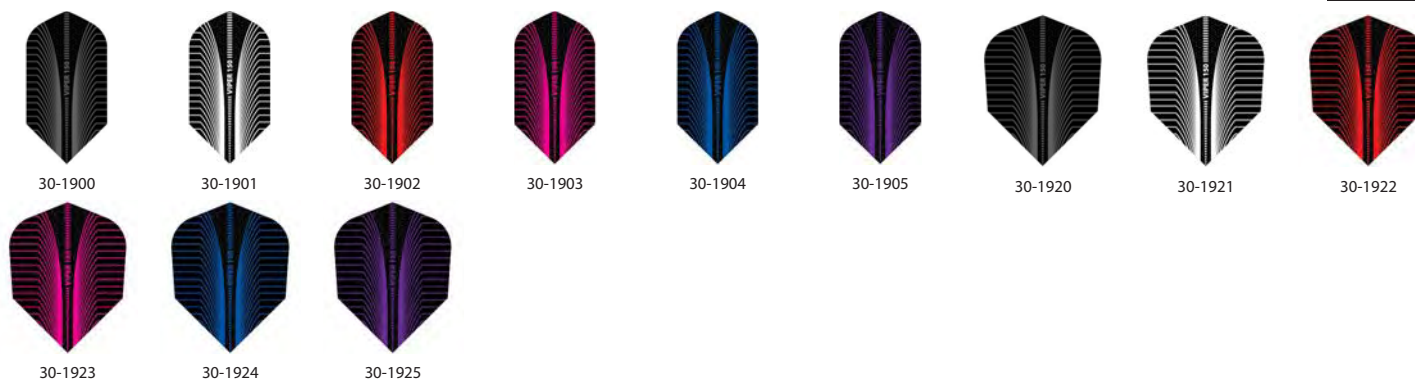

NEW PRODUCT

V-100 FLUX

Metallic, 100 Microns Thick

Sold in 5 packs, 3 flights per bag

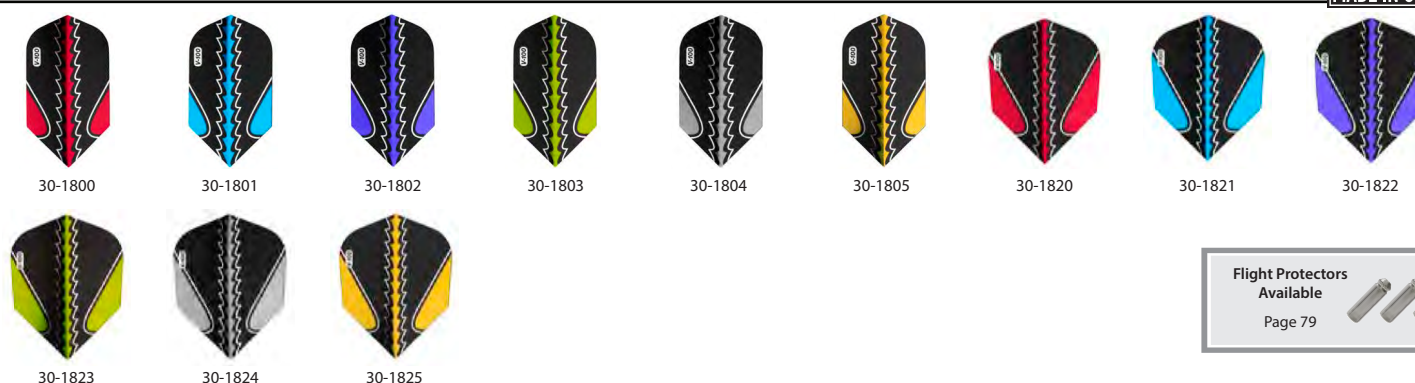

Flight Protectors Available
Page 79 

NEW PRODUCT

V-100 DIMPLEX® HYBRID

Metallic, 100 Microns Thick

Sold in 5 packs, 3 flights per bag



30-9100



30-9101



30-9102



30-9103



30-9104



30-9105



30-9106



30-9107



30-9108



30-9109

NEW PRODUCT

V-100 SINISTER™ SKULLS

100 Microns Thick

Sold in 5 packs, 3 flights per bag



30-3725



30-3726



30-3727



30-3728



30-3729



30-3700



30-3701



30-3702



30-3703



30-3704

V-100 SINISTER™

100 Microns Thick

Sold in 5 packs, 3 flights per bag



30-3105



30-3106



30-3108



30-3109



30-3113
TRANSLUCENT



30-3114
TRANSLUCENT



30-3117
TRANSLUCENT



30-3118
TRANSLUCENT



30-3119
TRANSLUCENT



30-3120
TRANSLUCENT



30-3121
TRANSLUCENT



30-3122



30-3124



30-3125



30-3126



30-3100



30-3104



30-3140
TRANSLUCENT



30-3143
TRANSLUCENT



30-3144
TRANSLUCENT



30-3145
TRANSLUCENT



30-3146
TRANSLUCENT



30-3148



30-3149

V-100 LUMACORE

Translucent, 100 Microns Thick

Sold in 5 packs, 3 flights per bag



30-6250
TRANSLUCENT



30-6251
TRANSLUCENT



30-6252
TRANSLUCENT



30-6265
TRANSLUCENT



30-6266
TRANSLUCENT



30-6267
TRANSLUCENT



30-6200
TRANSLUCENT



30-6201
TRANSLUCENT



30-6202
TRANSLUCENT

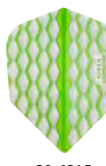

30-6215
TRANSLUCENT

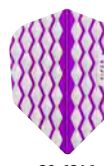

30-6216
TRANSLUCENT

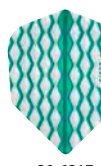

30-6217
TRANSLUCENT

V-100 ORYX

Translucent, 100 Microns Thick

Sold in 5 packs, 3 flights per bag

























 30-6150 TRANSLUCENT	 30-6151 TRANSLUCENT	 30-6152 TRANSLUCENT	 30-6153 TRANSLUCENT	 30-6154 TRANSLUCENT	 30-6155 TRANSLUCENT	 30-6156 TRANSLUCENT	 30-6157 TRANSLUCENT	 30-6158 TRANSLUCENT
 30-6159 TRANSLUCENT	 30-6160 TRANSLUCENT	 30-6161 TRANSLUCENT	 30-6162 TRANSLUCENT	 30-6163 TRANSLUCENT	 30-6164 TRANSLUCENT	 30-6165 TRANSLUCENT	 30-6166 TRANSLUCENT	 30-6100 TRANSLUCENT
 30-6101 TRANSLUCENT	 30-6102 TRANSLUCENT	 30-6103 TRANSLUCENT	 30-6104 TRANSLUCENT	 30-6105 TRANSLUCENT	 30-6106 TRANSLUCENT	 30-6107 TRANSLUCENT	 30-6108 TRANSLUCENT	 30-6109 TRANSLUCENT
 30-6110 TRANSLUCENT	 30-6111 TRANSLUCENT	 30-6112 TRANSLUCENT	 30-6113 TRANSLUCENT	 30-6114 TRANSLUCENT	 30-6115 TRANSLUCENT	 30-6116 TRANSLUCENT	<div style="border: 1px solid black; padding: 5px;"> <p>Flight Protectors Available </p> <p>Page 79</p> </div>	

V-100

100 Microns Thick

Sold in 5 packs, 3 flights per bag



 30-2855	 30-3600 METALLIC	 30-3601 METALLIC	 30-3602 METALLIC	 30-3608	 30-6350 TRANSLUCENT	 30-6450 TRANSLUCENT	 30-6451 TRANSLUCENT
 30-6452 TRANSLUCENT	 30-6453 TRANSLUCENT	 30-6454 TRANSLUCENT	 30-6455 TRANSLUCENT	 30-6456 TRANSLUCENT	 30-6457 TRANSLUCENT	 30-3500 METALLIC	 30-3501 METALLIC
 30-3504 METALLIC	 30-3510	 30-3525 TRANSLUCENT	 30-3526 TRANSLUCENT	 30-3527 TRANSLUCENT	 30-6400 TRANSLUCENT	 30-6401 TRANSLUCENT	 30-6402 TRANSLUCENT
 30-6403 TRANSLUCENT	 30-6404 TRANSLUCENT	 30-6405 TRANSLUCENT	 30-6406 TRANSLUCENT	 30-6407 TRANSLUCENT			

V-75 LUX 75 Microns Thick

Sold in 5 packs, 3 flights per bag



30-2200



30-2201



30-5104



30-5114



30-5137



30-5138



30-5156



30-5159



30-5176



30-5180



30-5182



30-5204



30-5245



30-5260



30-5690
MICRO



30-3176



30-5317



30-5379



30-5420



30-5424



30-5463



30-5472



30-5757



30-5796

V-75 75 Microns Thick

Sold in 5 packs, 3 flights per bag



30-2553



30-2561



30-2566



30-2579



30-2581



30-2699



30-2814



30-2947



30-2963



30-3411



30-3412



30-2401



30-2441



30-2420



30-2462



30-2471



30-2478



30-2493



30-2619



30-2710



30-2817



30-3400



30-2700

V-Riptex 150 Microns Thick *Heavy-duty 150 micron thick lasts longer than conventional flights*

Sold in 5 packs, 3 flights per bag



30-1734



30-1735



30-1736



30-1737



30-1739



30-1742



30-1744



30-1700



30-1704



30-1705



30-1706



30-1754



30-8719	30-8951	30-9316	30-9347	30-9349	30-9356	30-9357	30-9359	30-9366
30-9915	30-9002	30-9003	30-9025	30-9029	30-9082	30-9600	30-9608	

PENTATHLON



30-1998 EMBOSSED	30-2000 TRANSLUCENT	30-2001	30-2051	30-2052	30-2057	30-2059	30-2068	30-2067	30-2071
30-2093 TRANSLUCENT	30-2095 TRANSLUCENT	30-2101	30-2102	30-2365	30-2366	30-2367	30-2368	30-2373	30-2375
30-2388	30-2389	30-3075	30-3076	30-3077	30-3078	30-3079	30-3080	30-3225 TRANSLUCENT	30-3226 TRANSLUCENT
30-3227 TRANSLUCENT	30-3228 TRANSLUCENT	30-3229 TRANSLUCENT	30-3230 TRANSLUCENT	30-3231 TRANSLUCENT	30-3232 TRANSLUCENT	30-3233 TRANSLUCENT	30-3234 TRANSLUCENT	30-3235 TRANSLUCENT	30-1988
30-2047 MICRO TRANSLUCENT	30-2054	30-2060	30-2063	30-2073 TRANSLUCENT	30-2088 TRANSLUCENT	30-2090 TRANSLUCENT	30-2091 TRANSLUCENT	30-2369 TRANSLUCENT	30-2370 TRANSLUCENT
30-2371 TRANSLUCENT	30-2384	30-2382 TRANSLUCENT	30-2035	30-2019 TRANSLUCENT	30-2039 TRANSLUCENT	30-2381 TRANSLUCENT			

Flight Protectors Available
Page 79



PENTATHLON HD

150 Microns Thick

Sold in 5 packs, 3 flights per bag

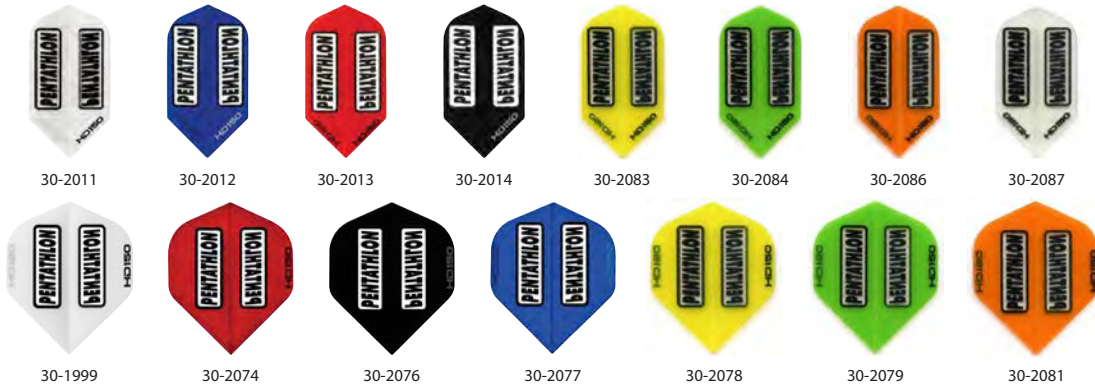

30-2011 30-2012 30-2013 30-2014 30-2083 30-2084 30-2086 30-2087
 30-1999 30-2074 30-2076 30-2077 30-2078 30-2079 30-2081

PENTATHLON 180s

Sold in 5 packs, 3 flights per bag

180 Microns Thick
 Heavy-duty 180 micron thick flights last longer than conventional flights



SPECIALTY

100 Microns Thick

Sold in 5 packs, 3 flights per bag



30-4150 30-4151 30-4154 30-4152 30-4153 30-4155
 30-8150 30-8151 30-8152 30-8153 30-8154 30-8155
 30-8175 30-8176 30-8177 30-8178 30-8179 30-8180

COMMERCIAL BAR DART PIECES



1-piece molded 1/4" thread plastic flight and shaft
 100 PIECES PER BAG



BLACK 34-5300-01
 RED 34-5300-02
 BLUE 34-5300-03
 YELLOW 34-5300-07

AMAZON

100 Microns Thick
 Heavy-duty 100 micron thick flights last longer than conventional flights

Sold in 5 packs, 3 flights per bag



30-6050 TRANSLUCENT 30-6056 TRANSLUCENT 30-6000 30-6001 30-6002 30-6003
 30-6006 30-6007 30-6008 30-6010 TRANSLUCENT 30-6012 TRANSLUCENT 30-6015 TRANSLUCENT

WIDOWS™ DARTS FLIGHT SHAFTS



These extra flight shafts are compatible with the Black, Gold, and Silver Widows™, see page 71.



RED 35-5311-02
 BLACK 35-5310-01

ALCHEMY

100 Microns Thick

Sold in 5 packs, 3 flights per bag



30-1602 30-1603 30-1651 30-1652 30-1653 30-1655 30-1656



B

LOOK FOR THE BUY IN BULK SYMBOL IN THE ACCESSORIES SECTION FOR HIGHER QUANTITY BUNDLES

FLIGHT PUNCH

- Heavy duty steel and resin
- Punches a perfect slot into dart flights for stem rings to hold flights secure
- Prevents flights from popping off
- Includes 3 sets of Viper® Slot Lock Rings

37-0103

*Flights and shafts not included



ASSORTED FLIGHTS



- | | |
|--|------------|
| 50 SETS OF ASSORTED V-RIPTEX FLIGHTS | 30-1700-97 |
| 50 SETS OF ASSORTED DIMPLEX® | 30-9000-97 |
| 50 SETS OF ASSORTED DIMPLEX® SLIM | 30-9300-98 |
| 50 SETS OF ASSORTED POLY ROYAL | 30-2400-97 |
| 50 SETS OF ASSORTED V-75 LUX | 30-5100-97 |
| 50 SETS OF ASSORTED V-75 LUX SLIM | 30-5100-98 |
| 50 SETS OF ASSORTED V-75 LUX STANDARD | 30-5300-99 |

FLIGHT CARD

- Holds 40 sets of flights

- | | |
|--------------------------------|------------|
| EMPTY CARD | 40-0601 |
| CARD W/V-75 LUX FLIGHTS | 30-5199-01 |
| CARD W/DIMPLEX® FLIGHTS | 30-9099-01 |
| CARD W/V-100 FLIGHTS | 30-2499-01 |



NEW PRODUCT

PATRIOT PACK



- 7 Sets of flights, 21 flights per pack

- | | |
|-----------------|------------|
| SLIM | 30-0020-50 |
| STANDARD | 30-0010-50 |



FLIGHT PROTECTORS

- Aluminum Flight Protectors
- 3 per pack sold in 5 packs
- Protects flight during deflection

- | | |
|--|-------------------|
| | 37-1500-00 SILVER |
| | 37-1500-01 BLACK |
| | 37-1500-02 RED |
| | 37-1500-03 BLUE |
| | 37-1500-04 GOLD |
| | 37-1500-06 PURPLE |



B Bulk 100 Sets

- | |
|----------------------------|
| 38-1500-00 SILVER 100 SETS |
| 38-1500-01 BLACK 100 SETS |
| 38-1500-02 RED 100 SETS |
| 38-1500-03 BLUE 100 SETS |
| 38-1500-04 GOLD 100 SETS |
| 38-1500-06 PURPLE 100 SETS |

FLIGHT PROTECTOR KIT

1 Flight Protector Applicator and 6 Flight Protectors | Sold in 5 Packs

- Extend the life of your flights by protecting their weak points
- Enough protectors to cover multiple sets, ensuring a steady supply
- Easy-on applicator takes the guess work out of assembly

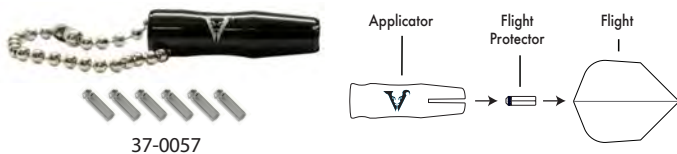

VIPERLOCK SHAFT RINGS

- 3 per pack sold in 5 packs
- Locks flights onto dart shaft



STEM RINGS

Sold in 5 packs, 3 per bag

- Set of 3 keeps the top of nylon shafts tight

- | | |
|----------------------|---------|
| 5 PACKS | 37-0138 |
| BULK 100 SETS | 38-0138 |

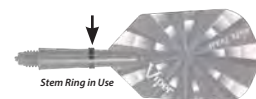

O-RINGS

Sold in 5 packs or bulk bags

- Set of 6 keeps the threaded end of aluminum shafts tight

- | | |
|----------------------|---------|
| 2BA O-Rings | |
| 5 PACKS OF 6 | 37-1400 |
| BULK 300 CT. | 38-1400 |
| BULK 1000 CT. | 38-1401 |



SHAPER STONE

1 Shaper Stone | Sold in 5 Packs

- Great for keeping the point of a steel tip in shape for play
- Genuine leatherette keyring



37-0127

BROKEN SHAFT REMOVER

1 Broken Shaft Remover | Sold in 5 Packs

- Unique design grips broken threads stuck in dart barrels
- Extend the life of your dart barrels by removing broken shafts
- Sleek black color matches dart cases and wallets
- Attached chain ensures that you are never without this essential tool

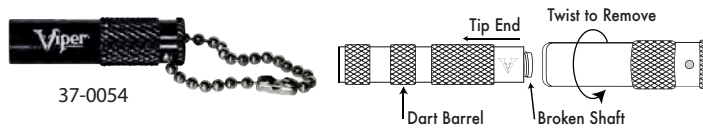

SHAFT LOCK KIT

1 O-Ring Applicator and 25 O-Rings | Sold in 5 Packs

- Ensure that your dart shafts never come loose when you use O-Rings
- These essential pieces have never been easier to use with this applicator
- A tight fitting shaft reduces wobbling for a perfect flight path every time

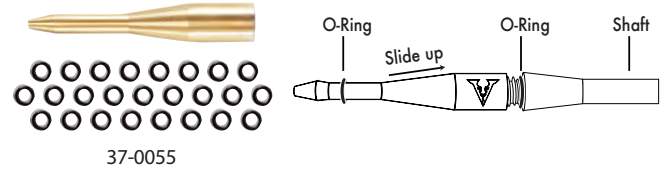

DART MECHANIC WRENCH

Display comes with an order of 20 or more | Sold in 10 Packs

- Tightens tips and metal shafts
- Spreads metal shafts for easy flight insertion
- Reshapes metal shafts



DARTBOARD HANGING KIT

1 Wall Mounting Hanging Kit | Sold in 5 Packs

- Designed for mounting all bristle dartboards
- Includes bracket, 3 spring clips, and screws
- Strong steel pieces and heavy duty screws hold dartboard securely to the wall or cabinet



ELKADART® O-RING APPLICATOR

- Alloy tool to aid in applying washers and o-rings
- Sold in 5 packs
- Trademarks used with permission and are owned by Elkadart®

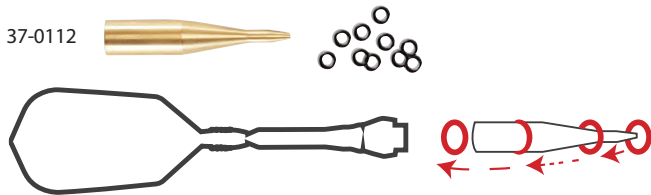

ELKADART® SHAFT REMOVER

1 Broken Shaft Remover | Sold in 5 Packs

- Removes broken plastic shafts from barrels
- Helps preserve barrels
- Trademarks used with permission and are owned by Elkadart®

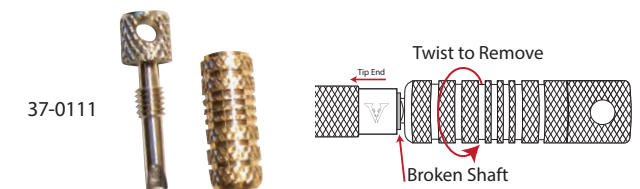

NEW PRODUCT VIPERLOCK ALUMINUM

- Durable aluminum shaft
- 2BA thread size

- Includes 1 Locking pin and 3 O-Rings per set

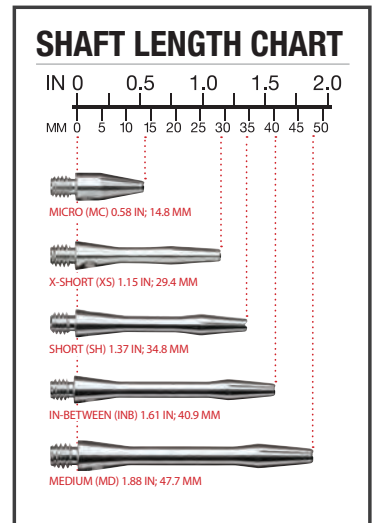

VIPERLOCK

- Durable Polycarbonate shaft
- Easy fit flight slots
- Pressure molded polymer matrix
- Locking ring adjusts to different flights



VIPERLOCK SHADE

- Durable Polycarbonate shaft
- Easy fit flight slots
- Pressure molded polymer matrix
- Locking ring adjusts to different flights



SHOCKWAVE

- Rotating top for minimal deflection
- Sold in 5 packs, 3 per package

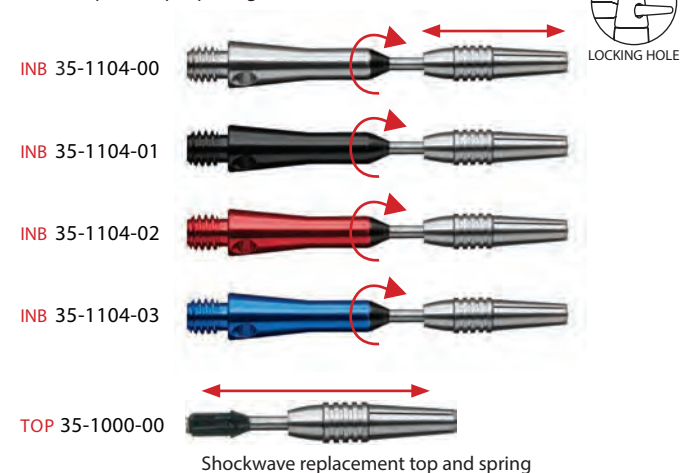

B NYLON

- Pliable nylon construction available in x-short, short, and medium lengths
- Sold in 5 packs, 3 per bag



Replacement Viperlock Shaft Rings Page 79 

CARBON PLUS

A revolutionary first in its industry. Ultra light and strong graphite rod gives a unique front weighted balance to any dart. An anodized linker helps create aerodynamic perfection.



Sold in 5 packs, 3 per bag



STARBURST

- Aluminum shaft available in in-between length only
 - Stripe enhanced center diamond cuts
 - Sold in 5 packs, 3 per bag.



ALUMINUM SPINSTER™ YUKON

- Rotating top for minimal deflection
 - Sold in 5 packs, 3 per pack



SPINSTER™ ALUMINUM

- Aluminum shaft available in short and medium lengths
 - Rotating top, replacement tops sold separately
 - Sold in 5 packs, 3 per pack



B COLOR MASTER

- Grooved aluminum shaft available in assorted lengths
 - Sold in 5 packs, 3 per bag



V GLO

- Aluminum shafts
 - Sold in 5 packs, 3 per bag



NEW PRODUCT SPIN

- Spin plastic shafts, sold in 5 packs, 3 per bag



B ALUMINUM

- Aluminum shaft available in assorted lengths
- Sold in 5 packs, 3 per bag

MC 35-6601-00
BULK 100 SETS. 34-6601-00



XSH 35-6602-00
BULK 100 SETS. 34-6602-00



SH 35-6603-00
BULK 100 SETS. 34-6603-00



INB 35-6604-00
BULK 100 SETS. 34-6604-00



MD 35-6605-00
BULK 100 SETS. 34-6605-00



MC 35-6601-01
BULK 100 SETS. 34-6601-01



XSH 35-6602-01
BULK 100 SETS. 34-6602-01



SH 35-6603-01
BULK 100 SETS. 34-6603-01



INB 35-6604-01
BULK 100 SETS. 34-6604-01



MD 35-6605-01
BULK 100 SETS. 34-6605-01



XSH 35-6602-02



SH 35-6603-02
BULK 100 SETS. 34-6603-02



INB 35-6604-02



MD 35-6605-02
BULK 100 SETS. 34-6605-02



XSH 35-6602-03



SH 35-6603-03
BULK 100 SETS. 34-6603-03



INB 35-6604-03
BULK 100 SETS. 34-6604-03



MD 35-6605-03
BULK 100 SETS. 34-6605-03



SH 35-6603-12



INB 35-6604-12



SPIDER LEG™

- Four wires in an aluminum base
- Encased with form-fitting wrap
- Available in medium length only
- Sold in 5 packs, 3 per bag

MD 35-5705-01



NEW PRODUCT

WIRE

- Slim, lightweight, and strong aluminum shafts with permanent tops
- Sold in 5 packs, 3 per bag



SH 35-9103-00



INB 35-9104-00



MD 35-9105-00



SH 35-9103-01



INB 35-9104-01



MD 35-9105-01



AL-XIII ALUMINUM

- Aircraft-Grade Aluminum shaft
- Sold in 5 packs, 3 per bag



INB 35-6704-00



SH 35-6703-00



INB 35-6704-01



SH 35-6703-01



INB 35-6704-02



SH 35-6703-02



INB 35-6704-03



SH 35-6703-03



VIPER® DIAMOND CUT

- Aluminum shaft featuring high-tech vertical grooves
- Available in short and in-between lengths
- Sold in 5 packs, 3 per bag



SH 35-6303-01



INB 35-6304-01



SH 35-6303-02



INB 35-6304-02



SH 35-6303-03



INB 35-6304-03



COLOSSAL JAR OF TIPS

500 2BA Tufflex Tips® II

- Standard 2BA thread size fits most barrels
- Tufflex construction features an inner core cone to absorb the heaviest blows
- A massive amount of tips in a convenient jar



37-0056

B DIAMOND TIPS

- Super strong and heavy-duty
- Reinforced cone design
- Made to withstand the power of a 20 gram dart

2BA 1000 Ct. 37-1605-01



1/4" 1000 Ct. 37-1615-01



1000 Ct. (37-1605-01)
Bulk Bag

B 2BA TUFFLEX TIPS® III

- Black and Bright neon colored tips for easy visibility

BLACK 50 Ct. 37-1651-01
BLACK 100 Ct. 37-1652-01
BLACK 1000 Ct. 37-1650-01



WHITE 100 Ct.
37-1652-15
WHITE 1000 Ct.
37-1650-15



NEON ORANGE 100 Ct.
37-1652-09
NEON ORANGE 1000 Ct.
37-1650-09



NEON GREEN 100 Ct.
37-1652-10
NEON GREEN 1000 Ct.
37-1650-10



NEON YELLOW 100 Ct.
37-1652-11
NEON YELLOW 1000 Ct.
37-1650-11



NEON PINK 100 Ct.
37-1652-12
NEON PINK 1000 Ct.
37-1650-12



100 Ct. (37-1652-01)
Display box



1000 Ct. (37-1650-01)
Bulk Bag

B 2BA TUFFLEX TIPS® SS



- Super strong and heavy-duty
- Reinforced cone design
- Made to withstand the power of a 20 gram dart

BLACK 50 Ct. 37-1692-01
BLACK 100 Ct. 37-1691-01
BLACK 150 Ct. 37-1693-01
BLACK 1000 Ct. 37-1690-01
BLACK 15,000 Ct. 38-1690-01



100 Ct. (37-1691-01)
Display box

BLUE 50 Ct. 37-1692-03
BLUE 100 Ct. 37-1691-03
BLUE 1000 Ct. 37-1690-03
BLUE 15,000 Ct. 38-1690-03



1000 Ct. (37-1690-01)
Bulk bag



B 2BA TUFFLEX TIPS® II



- Super strong and heavy-duty
- Reinforced cone design
- Made to withstand the power of a 20 gram dart

BLACK 50 Ct. 37-1604-01
BLACK 100 Ct. 37-1603-01
BLACK 500 Ct. 37-1602-01
BLACK 11,000 Ct. 38-1602-01



100 Ct. (37-1603-01)
Display box

RED 50 Ct. 37-1604-02
RED 100 Ct. 37-1603-02
RED 500 Ct. 37-1602-02



500 Ct. (37-1602-01)
Bulk bag

BLUE 50 Ct. 37-1604-03
BLUE 100 Ct. 37-1603-03
BLUE 500 Ct. 37-1602-03



B 1/4 TUFFLEX TIPS® II



- Super strong and heavy-duty
- Reinforced cone design
- Made to withstand the power of a 20 gram dart

BLACK 50 Ct. 37-1608-01
BLACK 100 Ct. 37-1607-01
BLACK 500 Ct. 37-1606-01



SINISTER™ CONVERTER POINTS

- Converts soft tip darts to steel tip darts
- Sold in 5 packs, 3 per bag

2BA NICKEL 37-1010-00



2BA BLACK 37-1010-01



B SOFT TIP ADD-A-GRAM

- Add-a-gram adjusts the weight of your dart
- Sold in 5 packs, 3 per bag
- Available in bulk sets of 100

2BA NICKEL 37-1100 2 gm.
BULK 100 SETS 38-1100



1/4" NICKEL 37-1102 1 gm.
BULK 100 SETS 38-1102

1/4" NICKEL 37-1112 2 gm.
BULK 100 SETS 38-1112



1/4" NICKEL 37-1122 3 gm.
BULK 100 SETS 38-1122

B STEEL TIP CONVERTER POINTS

- Converts soft tip darts to steel tip
- Sold in 5 packs, 3 per bag
- Available in bulk sets of 100

2BA NICKEL 37-1000
BULK 100 SETS 38-1000



2BA ALLOY 37-1001
BULK 100 SETS 38-1001



2BA BLK ALUMINUM 37-1004
BULK 100 SETS 38-1004



TOURNAMENT PINS Sold in 5 packs



37-0600



37-0601



37-0602



37-0603



37-0607



37-0609



37-0610



37-0611



37-0612



37-0613



37-0614



37-0615



37-0617



37-0621



37-0622



37-0623



37-0624



37-0625



37-0626



37-0628

VIPER® ADDITIONAL PRODUCTS



3 DART DISPLAY 40-0700

- Made from 1/4" clear acrylic
- Anti-slip feet keep display in place
- DARTS NOT INCLUDED



LARGE ACCESSORY BOX 37-0144

FLIGHTS NOT INCLUDED



SMALL ACCESSORY BOX 37-0143

FLIGHTS NOT INCLUDED



BLANK HANGSELL CASE 36-0001



2" x 3" PRINTED BAGS 37-0201

Sold in packs of 100



ROSIN BAGS 37-0131

Sold in display box of 12

CASEMASTER®



ADJUSTABLE LENGTH



NEW PRODUCT

NOMAD

BLACK	36-1000-01
RED	36-1000-02
BLUE	36-1000-03
PURPLE	36-1000-06
ORANGE	36-1000-09
NEON GREEN	36-1000-10
NEON YELLOW	36-1000-11
NEON PINK	36-1000-12
NEON BLUE	36-1000-16
CLEAR	36-1000-19

CASE 5.38"L x 3.5"W x 1.5"H

FEATURES

- Comfortably holds a set of fully assembled darts up to 6.5 inches long
- Form-fitting shell won't crush your dart flights and is spacious enough to fit molded, slim, and standard dart flights
- Works with both steel and soft tip darts, as well as any flight shape
- Includes a carabiner clip so you can easily attach your Nomad dart case to a bag, backpack, purse, or belt loop
- Available in 10 different color options for maximum customization
- Limited 90 day warranty

DARTS & ACCESSORIES NOT INCLUDED



NEW PRODUCT

SENTINEL ART SERIES

AMERICAN FLAG **36-9000**

GOLD MAZE **36-9001**

SINISTER SKULLS **36-9002**

TIE DYE **36-9003**

GALAXY **36-9004**

BLACK CAMO **36-9005**

CASE 7.75"L x 5.25"W x 1.88"H



FEATURES

- Extra wide profile holds six darts up to 6" in length in hard foam slots, without crushing flights
- Perfect-fit slots and pockets carry all the accessories you need for a night out for darts
- Durable and rigid TacTech outer shell protects the contents from drops and impacts
- Textured surface grips difficult or wet surfaces to minimize drops
- Available in six patterns
- Limited 90 day warranty

DARTS & ACCESSORIES NOT INCLUDED



PLAZMA

- NEW** BLACK 36-0700-01
- NEW** RUBY 36-0700-02
- BLUE 36-0700-03
- NEW** AMETHYST 36-0700-06
- ORANGE 36-0700-09
- GREEN 36-0700-10
- YELLOW 36-0700-11
- PINK 36-0700-12
- NEW** SAPPHIRE 36-0700-16

CASE 7.5"L x 4.13"W x 1.88"H

FEATURES

- Foam slots firmly holds 3 fully assembled darts
- 12 Pockets for easy storage of accessories
- Front zip pocket for extra storage
- Accessory tube perfect for dart tip storage
- Fits darts long in length
- Available in 9 colors
- Limited 90 day warranty

DARTS & ACCESSORIES NOT INCLUDED



PLAZMA PLUS

- NEW** BLACK 36-0701-01
- NEW** RUBY 36-0701-02
- BLUE 36-0701-03
- NEW** AMETHYST 36-0701-06
- ORANGE 36-0701-09
- GREEN 36-0701-10
- YELLOW 36-0701-11
- PINK 36-0701-12
- NEW** SAPPHIRE 36-0701-16

CASE 7.5"L x 4.13"W x 2.88"H

FEATURES

- Foam slots firmly holds 3 fully assembled darts
- 12 Pockets for easy storage of accessories
- Front zip pocket for extra storage
- Extra outer pocket fits mobile phones or glasses
- Accessory tube perfect for dart tip storage
- Fits darts long in length
- Available in 9 colors
- Limited 90 day warranty

DARTS & ACCESSORIES NOT INCLUDED





PLAZMA PRO



- NEW** BLACK 36-0702-01
- NEW** RUBY 36-0702-02
- BLUE 36-0702-03
- NEW** AMETHYST 36-0702-06
- ORANGE 36-0702-09
- GREEN 36-0702-10
- YELLOW 36-0702-11
- PINK 36-0702-12
- NEW** SAPPHIRE 36-0702-16

CASE 7.63"L x 4.25"W x 3.63"H

FEATURES

- Foam slots firmly holds 6 fully assembled darts
- Inner perfect-fit zip pocket carries all the accessories
- 16 Pockets for easy storage of accessories
- Front zip pocket for extra storage
- Extra outer pocket fits mobile phones or glasses
- 2 Accessory tubes perfect for dart tip storage
- Fits darts long in length
- Available in 9 colors
- Limited 90 day warranty

DARTS & ACCESSORIES NOT INCLUDED



NEW PRODUCT

SPORT



- BLACK 36-0610-01
- RED 36-0610-02
- BLUE 36-0610-03

CASE 7.21"L x 3.86"W x 1.97"H

FEATURES

- Stitched holsters firmly hold 3 soft or steel tip darts and extended Flight Form profile protects open flights from being crushed
- Perfect-fit pockets and rigid EVA foam insert store all the accessories you need for a night of darts
- Durable and rigid TacTech outer shell protects the contents from drops and impacts
- Smooth design looks sleek and professional
- Textured surface grips difficult or wet surfaces to minimize drops
- Available in three colors
- Limited 90 day warranty

DARTS & ACCESSORIES NOT INCLUDED





NEW PRODUCT



SENTINEL

AMERICAN FLAG MONOCHROME **36-0602-99**

CASE 7.75"L x 5.25"W x 1.88"H

FEATURES

- Extra wide profile holds six darts up to 6" in length in hard foam slots, without crushing flights
- Perfect-fit slots and pockets carry all the accessories you need for a night out for darts
- Durable and rigid TacTech outer shell protects the contents from drops and impacts
- Textured surface grips difficult or wet surfaces to minimize drops
- Available in three colors
- Limited 90 day warranty

DARTS & ACCESSORIES NOT INCLUDED



SENTINEL

BLACK **36-0602-01**

RED **36-0602-02**

BLUE **36-0602-03**

CASE 7.75"L x 5.25"W x 1.88"H

FEATURES

- Extra wide profile holds six darts up to 6" in length in hard foam slots, without crushing flights
- Perfect-fit slots and pockets carry all the accessories you need for a night out for darts
- Durable and rigid TacTech outer shell protects the contents from drops and impacts
- Smooth design looks sleek and professional
- Textured surface grips difficult or wet surfaces to minimize drops
- Available in three colors
- Limited 90 day warranty

DARTS & ACCESSORIES NOT INCLUDED





WARDEN

BLACK 36-0600-01

RED 36-0600-02

BLUE 36-0600-03

CASE 7.75"L x 3.75"W x 1.88"H

FEATURES

- Rigid foam slots firmly holds three fully assembled darts up to 6" in length, without crushing open flights
- One perfect-fit zip pocket carries all the accessories you need for a night out for darts
- Durable and rigid TacTech outer shell protects the contents from drops and impacts
- Smooth design looks sleek and professional
- Textured surface grips difficult or wet surfaces to minimize drops
- Available in three colors
- Limited 90 day warranty

DARTS & ACCESSORIES NOT INCLUDED



SENTRY

BLACK 36-0601-01

RED 36-0601-02

BLUE 36-0601-03

CASE 7.75"L x 3.75"W x 2.13"H

FEATURES

- Rigid foam slots firmly holds six fully assembled darts up to 6" in length, without crushing flights
- Six perfect-fit slots carry all the accessories you need for a night out for darts
- Durable and rigid TacTech outer shell protects the contents from drops and impacts
- Smooth design looks sleek and professional
- Textured surface grips difficult or wet surfaces to minimize drops
- Available in three colors
- Limited 90 day warranty

DARTS & ACCESSORIES NOT INCLUDED





SINISTER™ ALUMINUM

BLACK 36-0375

CASE 6.75"L x 4"W x 1.38"H

FEATURES

- Protect your darts from damage with a highly durable aluminum shell case
- The magnetic locking mechanism holds tightly closed and has no pieces to break
- Hard EVA foam holds your darts and accessories in place in case of sudden movements
- Holds one complete set of darts without crushing flights
- Four flight slots for extra flights
- Two wrench slots, six extra shaft slots, ten extra tip slots
- Limited 90 day warranty

DARTS & ACCESSORIES NOT INCLUDED



LEGION

BLACK 36-0402-01

CASE 8"L x 10.25"W x 2.5"H

FEATURES

- Richly embossed aluminum case
- Holds three complete sets of darts
- Twelve pockets for extra flights and wrench
- Ten mini-sleeves for extra shafts or soft tips
- Two plastic containers for extra tips or other accessories
- One large accessory pocket
- Limited 90 day warranty

DARTS & ACCESSORIES NOT INCLUDED





TERNION

BLACK 36-0404-01

CASE 7.5"L x 8"W x 2.5"H

FEATURES

- Richly embossed aluminum case
- Holds three complete sets of darts
- Eight pockets for extra flights or shafts
- Three mini sleeves for extra shafts or soft tips
- One plastic container for extra tips or other accessories
- One large accessory pocket
- Limited 90 day warranty

DARTS & ACCESSORIES NOT INCLUDED



SOLE

BLACK 36-0403-01

CASE 7.5"L x 3.5"W x 2.5"H

FEATURES

- Richly embossed aluminum case
- Holds one complete set of darts
- Eight pockets for extra flights
- Limited 90 day warranty

DARTS & ACCESSORIES NOT INCLUDED



ACCOLADE

BLACK 36-0401-01

CASE 7.25"L x 2.5"W x 1.5"H

FEATURES

- Richly embossed aluminum case
- Holds one complete set of darts
- Five pockets to hold flight or shafts
- Limited 90 day warranty

DARTS & ACCESSORIES NOT INCLUDED





THE PRO

BLACK **36-0908-01**

CASE 10.5"L x 8"W x 2.25"H

FEATURES

- Foam cushioned inserts
- Holds three complete sets of darts
- Four storage tubes for accessories
- Fifteen pockets for easy storage of accessories
- Black leatherette
- Limited 90 day warranty

DARTS & ACCESSORIES NOT INCLUDED



CLASSIC

BLACK **36-0900-01**

BLUE **36-0900-03**

CASE 8"L x 10.25"W x 2.5"H

FEATURES

- Foam cushioned inserts
- Holds four complete sets of darts
- Five storage tubes for accessories
- Fifteen pockets
- Durable nylon
- Limited 90 day warranty

DARTS & ACCESSORIES NOT INCLUDED





ELITE JR.

BLACK **36-0901-01**
 CASE 7.25"L x 4.25"W x 3"H

FEATURES

- Foam cushioned inserts
 - Holds two complete sets of darts
 - Two storage tubes for accessories
 - Six pockets for darting accessories
 - Durable nylon
 - Limited 90 day warranty
- DARTS & ACCESSORIES NOT INCLUDED



SELECT

BLACK **36-0902-01**
 BLUE **36-0902-03**
 PINK **36-0902-12**
 CASE 7.25"L x 4.75"W x 2"H

FEATURES

- Foam cushioned insert
 - Holds one complete sets of darts
 - One storage tube for accessories
 - Six pockets for easy storage of accessories
 - Durable nylon
 - Limited 90 day warranty
- DARTS & ACCESSORIES NOT INCLUDED





DELUXE

BLACK 36-0802-01

PINK 36-0802-12

REALTREE® HD 36-0802-99

CASE 3.5"L x 7"W x 1"H

FEATURES

- Holds two complete sets of darts
- Eight pockets for darting accessories
- Durable nylon
- Limited 90 day warranty

DARTS & ACCESSORIES NOT INCLUDED

REALTREE HARDWOODS HD © 2001 of Jordan Outdoor Enterprises, Ltd, All rights reserved



SINGLE

BLACK 36-0800-01

CASE 7"L x 4"W x 1"H

FEATURES

- Holds one complete set of darts
- Removable insert to protect tips and barrels
- Two pockets for darting accessories
- Durable nylon
- Belt loop
- Limited 90 day warranty

DARTS & ACCESSORIES NOT INCLUDED



BELT LOOP





VIPER® UNPRINTED DELUXE DART PAL®

BLACK INTERIOR **36-0276-01**

WHITE INTERIOR **36-0276-15**

CASE 7.25"L x 4.25"W x 1"H

FEATURES

- Sturdy, crush-proof ABS exterior
- Holds one complete set of darts, wrench, shafts, flight protectors, tips, and flights

DARTS & ACCESSORIES NOT INCLUDED

US Patent #D359617



VIPER® VIPER® PRINTED DELUXE DART PAL®

VIPER® LOGO **36-0117**

CASE 7.25"L x 4.25"W x 1"H

FEATURES

- Sturdy, crush-proof ABS exterior
- Holds one complete set of darts, wrench, shafts, flight protectors, tips, and flights

DARTS & ACCESSORIES NOT INCLUDED

US Patent #D359617



SMALL STORAGE TUBE 36-0904

5.5"L x 0.88"W x 0.88"H
Sold in 5 packs

TIPS NOT INCLUDED



DARTBOARDS

LED CRICKET OVERHEAD SCORING DISPLAY

BUILT-IN DART STORAGE HOLDERS

EASY TO NAVIGATE CONTROL PANEL



LARGE ELECTRONIC SCOREBOARD

TARGET TESTED TOUGH™ COMMERCIAL GRADE NYLON SEGMENTS



ELECTRONIC DARTBOARDS

Electronic dartboards come in many styles, with sturdy ABS cabinets that are tough and are great for long time use. Each dartboard is comprised of Target Tested Tough® commercial grade nylon segments that out perform conventional plastic and have durable overhead displays for a better view of scores.

ULTRA THIN SPIDER REDUCES BOUNCE OUTS

GAME PANEL FOR QUICK REFERENCE

ELECTRONIC CRICKET SCORING DISPLAY

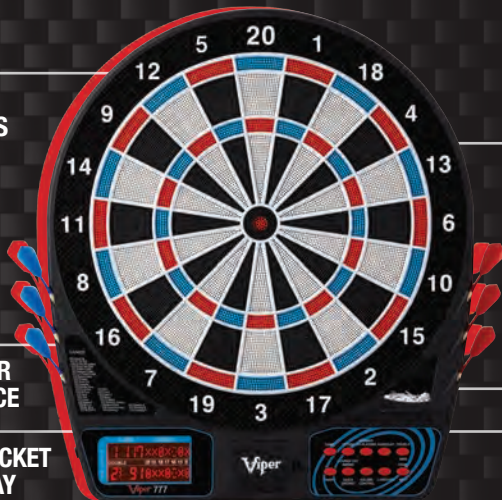

CATCH RING PROTECTS WALL FROM MISSED DARTS

BUILT IN TIP STORAGE

EASY TO NAVIGATE CONTROL PANEL

BOARD VARIETIES

Many dartboards have an ultra thin spider to reduce bounced darts, with a 13" target face or a 15.5" league regulation target face. Some dartboards have AC power adapter option or battery for a travel adapter, and come with a built in storage tip tray and dart holsters.

RAZOR THIN WIRE PREVENTS BOUNCE OUTS

HIGH GRADE SELF-HEALING SISAL FIBERS

MOVABLE ANTI-GLARE NUMBER RING

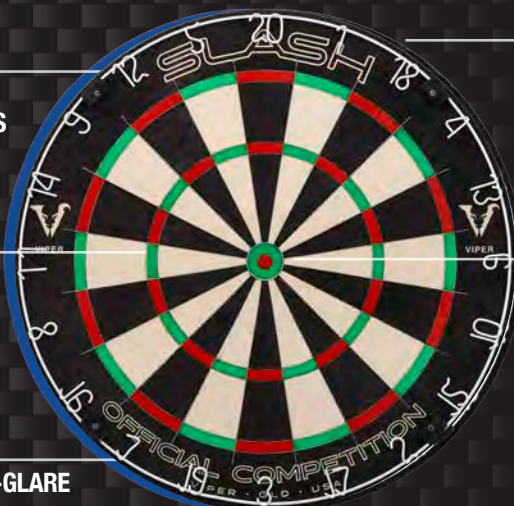

1.5" THICK STEEL COMPRESSION RING

STAPLE-FREE BULLSEYE



SISAL DARTBOARDS

Viper® sisal dartboards offer a staple-free bullseye and radial, triangular or razor wired spider, razor having the least bounced darts. Each dartboard is constructed from high-grade, self healing fibers that accommodate both steel and soft tip darts with a removable anti-glare number ring that adds life to your investment by allowing you to rotate the board for even wear.



VIPER® 850

ELECTRONIC 42-1060

The all-new state of the art Viper® 850 electronic dartboard provides the next level in dart gaming. Headlined by the ultra bright triple score display, the 850 provides the best scoring experience yet. Enhanced definition on the central display allows for better scoring graphics than ever before seen, while the traditional double cricket display utilizes the best brightest LED in the industry for high visibility.

DIMENSIONS	24.25"L x 19.5"W x 1.15"H
ITEM WEIGHT	5 lbs
NET WEIGHT	7.2 lbs
GROSS WEIGHT	22.5 lbs
NUMBER OF GAMES	50
NUMBER OF OPTIONS	470
NUMBER OF PLAYERS	8
DISPLAY	2 LED Cricket 1 Matrix Light Point
SPIDER	Ultra-thin
CARTON OF	4



FEATURES

- Regulation 15.5" target face
- Concave segment holes
- 5 Programmable favorite game shortcuts
- Missed darts catch ring
- Single/double bull options
- Computer match with 5 skill levels
- Bounce out button/miss button
- Quick key for Cricket
- Limited 1 year warranty

ACCESSORIES

- 6 Starter darts
- 24 Extra tips
- Pro Line measuring tape
- Dartboard throwline
- Game manual
- Mounting hardware
- Power adapter (#42-9987, 100-240V 50-60Hz AC to 5V DC at 1000mA, positive outside to negative center)



2 LED CRICKET DISPLAYS



1 LIGHT POINT MATRIX DISPLAY



3 LARGE DISPLAYS



ULTRA-THIN SPIDER, DURABLE HIGH-IMPACT THERMOPLASTIC SEGMENTS, AND MISSED DARTS CATCH RING



VIPER ION

ELECTRONIC 42-0003

Bring to light an entire new dimension of dart games with the Ion illuminated dartboard! This innovative new dartboard features extra bright LED lights that shine through the segments for enhanced game play, including exclusive games that rely on the new ION Light System.

DIMENSIONS	21.97"L x 19.49"W x 1.18"H
ITEM WEIGHT	3.96 lbs
NET WEIGHT	20.80 lbs
GROSS WEIGHT	22.31 lbs
NUMBER OF GAMES	48
NUMBER OF OPTIONS	315
NUMBER OF PLAYERS	8
DISPLAY	LED
SPIDER	Ultra-Thin
CARTON OF	2

FEATURES

- Regulation 15.5" target face
- 48 Games with 315 options
- Optional moving targets
- 17 Exclusive light based games
- Player V.S. CPU with 5 difficulty levels
- Auto power off
- Concave segment holes reduce bounce outs
- Target Tested Tough™ segments
- Up to 8 player multiplayer, including team play
- Built in storage for your darts and extra tips
- Battery or AC adapter operated (3AA NOT INCLUDED)
- Includes limited 1 year warranty

ACCESSORIES

- 6 Starter darts
- 24 Extra tips
- Pro Score measuring tape
- Dartboard throwline
- Game manual
- Mounting hardware
- Power adapter (#42-9987, 100-240V 50-60Hz AC to 5V DC at 1000mA, positive outside to negative center)

BATTERIES NOT INCLUDED



MOTION BASED LIGHT GAMES



SCROLLING CONTROL PANEL



ULTRA-THIN SPIDER, DURABLE HIGH-IMPACT THERMOPLASTIC SEGMENTS, AND MISSED DARTS CATCH RING

BILINGUAL
HABLO ESPAÑOL



VIPER ORION

ELECTRONIC **42-1036**

Channel your inner hunter with the Viper® Orion electronic dartboard. The Orion is fit for a mythical champion with its dual LCD displays, central game list for easy access, and easy-to-use navigation interface. Play 43 games with up to 8 players and 300 possible variations for a personalized darting experience. The customizable handicapping feature narrows the advantage between a skilled player and a beginner or provides an extra challenge for players who crave to hone their skills.

DIMENSIONS	23.43"L x 19.49"W x 1.18"H
ITEM WEIGHT	4.62 lbs
NET WEIGHT	18.52 lbs
GROSS WEIGHT	24.96 lbs
NUMBER OF GAMES	43
NUMBER OF OPTIONS	300
NUMBER OF PLAYERS	8
DISPLAY	2 Dual Color LCD displays, up to 4 players at once
SPIDER	Ultra-Thin
CARTON OF	4



#37-0025 FIND ON PAGE 137

FEATURES

- Regulation 15.5" target face
- 43 Games with over 300 options
- Concave segment holes reduce bounce outs
- Target Tested Tough™ segments
- Bilingual voice, in English or Spanish
- Up to 8 player multiplayer, including team play
- Two extra-large displays allow up to four players to see their scores at the same time, and can be seen from a distance
- 4 Volume levels
- Power saver mode
- Large dart catch ring
- Can see your average point per dart
- Built in storage for darts and extra tips
- Easy to use handicap feature
- Includes limited 1 year warranty

ACCESSORIES

- 6 Starter darts
- 24 Extra tips
- Pro Score measuring tape
- Dartboard throwline
- Game manual
- Mounting hardware
- Power adapter (#42-9987, 100-240V 50-60Hz AC to 5V DC at 1000mA, positive outside to negative center)



EASY TO NAVIGATE CONTROL PANEL



TWO LARGE LCD SCORING DISPLAYS

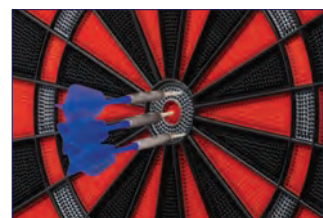

ULTRA-THIN SPIDER, DURABLE HIGH-IMPACT THERMOPLASTIC SEGMENTS, AND MISSED DARTS CATCH RING



VIPER SHOWDOWN

ELECTRONIC 42-0002

Claim your victory with the Showdown. Step up to the line and show them who's boss. The Viper® Showdown is the perfect board for casual play, competitive practice, and more. Its streamlined interface makes it fun and easy for everyone. Play 32 games with up to 8 players or practice your skills and play against the computer.

DIMENSIONS	21.97"L x 19.49"W x 1.18"H
ITEM WEIGHT	3.96 lbs
NET WEIGHT	20.80 lbs
GROSS WEIGHT	22.31 lbs
NUMBER OF GAMES	32
NUMBER OF OPTIONS	590
NUMBER OF PLAYERS	8
DISPLAY	LCD
SPIDER	Ultra-Thin
CARTON OF	4

FEATURES

- Regulation 15.5" target face
- 32 Games with 590 options
- Single in/out, double in/out, and master out game options
- Displays 01 games point per dart
- 25/50 Bull option
- Player ranking
- Auto power off
- Concave segment holes reduce bounce outs
- Target Tested Tough® segments
- Up to 8 player multiplayer, including team play
- Built in storage for your darts and extra tips
- Powered by 3 AA batteries for a cord free board
- Includes limited 1 year warranty

ACCESSORIES

- 6 Starter darts
- 24 Extra tips
- Pro Score measuring tape
- Dartboard throwline
- Game manual
- Mounting hardware

BATTERIES NOT INCLUDED



EASY TO NAVIGATE CONTROL PANEL



EASY TO READ LCD SCORING DISPLAY



ULTRA-THIN SPIDER, DURABLE HIGH-IMPACT THERMOPLASTIC SEGMENTS, AND MISSED DARTS CATCH RING



VIPER NEPTUNE

ELECTRONIC 42-1023

Make a stunning addition to your game room with the Viper® Neptune electronic dartboard with built in hybrid cabinet! Surrounding the target face is a large missed dart catch ring to protect your wall from errant throws while the built in cabinet doors feature convenient dart storage. The Neptune features 57 dart games, including the exclusive Spanish and Minnesota Cricket, and 307 scoring options to assure that you'll never run out of ways to put your darting skills on display. The stylish color scheme utilizes sharp red and gray on a deep black to ensure you can always see where your darts land.

- CLOSED DIMENSIONS** 26.5"L x 20.75"W x 2.5"H
- OPEN DIMENSIONS** 42"L x 26.5"W x 3.75"H
- ITEM WEIGHT** 22.5 lbs
- NET WEIGHT** 43 lbs
- GROSS WEIGHT** 49 lbs
- NUMBER OF GAMES** 57
- NUMBER OF OPTIONS** 307
- NUMBER OF PLAYERS** 16
- DISPLAY** 4-Person 6" XL LCD display
- SPIDER** Ultra-thin
- CARTON OF** 2

FEATURES

- Regulation 15.5" target face
- Concave segment holes
- Single/double in/out options for 01 games
- Single/double bullseye option
- Auto player change
- Extra large missed dart catch ring
- Exclusive Minnesota and Spanish Cricket games
- Front mounting for easy hanging
- Sleep mode and auto power off
- Best dart out for 01 games
- Eliminate score button
- Missed dart button
- Voice with 3 volume levels
- Voice prompts for next player/remove darts
- Most popular game keys for 301 & Cricket
- Computer match with 5 skill levels
- Storage for 2 sets of darts
- Bounce out button
- Limited 1 year warranty

ACCESSORIES

- 6 Starter darts
- 24 Extra tips
- Pro Score measuring tape
- Dartboard throwline
- Game manual
- Mounting hardware
- Power adapter (#42-9987, 100-240V 50-60Hz AC to 5V DC at 1000mA, positive outside to negative center)

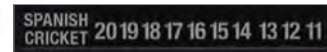

EXCLUSIVE SPANISH CRICKET SCOREBOARD



EXTRA LARGE DISPLAY



LARGE BUTTON CONTROL PANEL

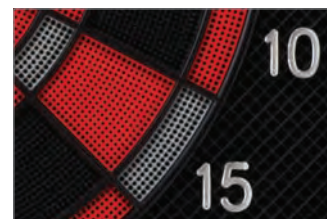

ULTRA THIN SPIDER



VIPER[®] SOLAR BLAST

ELECTRONIC 42-1021

Ignite your flare for competition with the Viper[®] Solar Blast electronic dartboard! The Solar Blast features 43 dart games and 187 scoring options to assure that you'll never run out of ways to scorch your adversaries. This dartboard comes equipped with an automatic LED scoreboard incorporated right into the board with Cricket displays so you'll never have to worry about inaccurate score keeping. Multiplayer options support up to 16 players, so no one needs to sit on the sideline.

DIMENSIONS	29"L x 21.75"W x 2"H
ITEM WEIGHT	10.39 lbs
NET WEIGHT	24.92 lbs
GROSS WEIGHT	25.55 lbs
NUMBER OF GAMES	43
NUMBER OF OPTIONS	187
NUMBER OF PLAYERS	16
DISPLAY	4-Person LED Cricket displays
SPIDER	Ultra-thin
CARTON OF	2



#37-0025 FIND ON PAGE 137

FEATURES

- Regulation 15.5" target face
- Concave segment holes
- Single or team computer opponent play with 3 difficulty levels
- Single/double in/out options for O1 games
- Double in/out
- Eliminate score button
- Handicap option
- Voice prompt for next player/remove darts
- Missed darts catch ring
- Front mounting for easy hanging
- Auto point per dart averaging/O1 games
- Auto player change
- Auto player ranking
- Voice with 4 volume levels
- Bounce out button
- Drawer for extra tips (extra tips not included)
- Slide-out game list
- Limited 1 year warranty

ACCESSORIES

- 6 Starter darts
- 24 Extra tips
- Pro Score measuring tape
- Dartboard throwline
- Game manual
- Mounting hardware
- Power adapter (#42-9987, 100-240V 50-60Hz AC to 5V DC at 1000mA, positive outside to negative center)



TRADITIONAL XO DISPLAY



EASY TO USE CONTROL PANEL



ULTRA-THIN SPIDER, DURABLE HIGH-IMPACT THERMOPLASTIC SEGMENTS, AND MISSED DARTS CATCH RING



VIPER 800

ELECTRONIC 42-1034

The Viper® 800 Electronic Dartboard is a darter's dream. Keeps track of 4 players' Cricket scores at once with its expansive LCD scoreboard. The 800 features 57 dart games and 429 scoring options, including the exclusive Spanish and Minnesota Cricket, to assure that you'll never run out of ways to destroy your adversaries.

DIMENSIONS	24.75"L x 20.25"W x 1.5"H
ITEM WEIGHT	6 lbs
NET WEIGHT	22.75 lbs
GROSS WEIGHT	24.3 lbs
NUMBER OF GAMES	57
NUMBER OF OPTIONS	429
NUMBER OF PLAYERS	16
DISPLAY	LCD Cricket/01 displays
SPIDER	Ultra-thin
CARTON OF	4

FEATURES

- Regulation 15.5" target face
- Concave segment holes
- Eliminate score button
- Missed darts catch ring
- Double in/out
- Exclusive Minnesota and Spanish Cricket
- Computer match with 5 skill levels
- Auto player change
- Voice with 4 levels plus sound effects
- Missed dart key
- 25/50 Bullseye option
- Bounce out button/Eliminate button
- Quick keys for 301/Cricket/Count Up
- Limited 1 year warranty

ACCESSORIES

- 6 Starter darts
- 24 Extra tips
- Pro Score measuring tape
- Dartboard throwline
- Game manual
- Mounting hardware
- Power adapter (#42-9987, 100-240V 50-60Hz AC to 5V DC at 1000mA, positive outside to negative center)

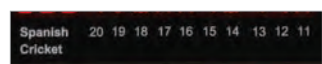

EXCLUSIVE SPANISH CRICKET SCOREBOARD



LARGE LCD SCOREBOARD



EASY TO USE CONTROL PANEL

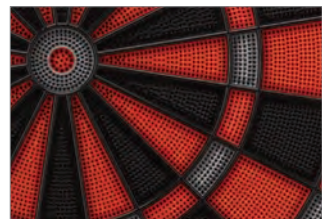

ULTRA-THIN SPIDER, DURABLE HIGH-IMPACT THERMOPLASTIC SEGMENTS, AND MISSED DARTS CATCH RING



#37-0025 FIND ON PAGE 137



VIPER 797

ELECTRONIC 42-1017

Made of target tested, commercial-grade nylon, the Viper® 797 Electronic Dartboard is designed and built to entertain a flexible number of players—from one to a crowd of 16. The electronic dartboard features an illuminated LCD display that can be read easily from the throw line, and the board provides a voice prompt for the next player up and dart removal to keep the action flowing.

DIMENSIONS	23.63"L x 19.63"W x 1.25"H
ITEM WEIGHT	5.5 lbs
NET WEIGHT	23.22 lbs
GROSS WEIGHT	24.68 lbs
NUMBER OF GAMES	43
NUMBER OF OPTIONS	231
NUMBER OF PLAYERS	16
DISPLAY	4-Person Cricket LCD display
SPIDER	Ultra-thin
CARTON OF	4

FEATURES

- Regulation 15.5" target face
- Concave segment holes
- Auto player ranking for 01 games
- Missed dart button
- Single or double bull option, 25/50
- Auto or manual player change option
- Single/double in/out options for 01 games
- Missed dart catch ring
- Front mounting for easy hanging
- Voice prompt for next player/remove darts
- Quick play buttons for Cricket and 01 games
- Bounce out button
- Adjustable volume with 3 levels
- Durable heavy duty cabinet
- Eliminate score button
- Limited 1 year warranty

ACCESSORIES

- 6 Starter darts
- 24 Extra tips
- Pro Score measuring tape
- Dartboard throwline
- Game manual
- Mounting hardware
- Power adapter (#42-9987, 100-240V 50-60Hz AC to 5V DC at 1000mA, positive outside to negative center)



ULTRA BRIGHT LCD DISPLAY



EASY TO USE CONTROL PANEL



ULTRA-THIN SPIDER, DURABLE HIGH-IMPACT THERMOPLASTIC SEGMENTS, AND MISSED DARTS CATCH RING



VIPER 787

ELECTRONIC 42-0001

Begin your darts journey with one of the best-selling electronic dartboards: the Viper® 787. The 787 features 43 dart games, including Cricket and 301, and over 241 scoring options to assure that you'll never run out of ways to put your darting skills on display.

DIMENSIONS	23.5"L x 19.5"W x 1.56"H
ITEM WEIGHT	6 lbs
NET WEIGHT	11.36 lbs
GROSS WEIGHT	12.7 lbs
NUMBER OF GAMES	43
NUMBER OF OPTIONS	241
NUMBER OF PLAYERS	16
DISPLAY	4-Person Cricket LCD display
SPIDER	Ultra-Thin
CARTON OF	2



Power adapter (#42-9987, 100-240V 50-60Hz AC to 5V DC at 1000mA, positive outside to negative center) Sold separately

FEATURES

- Regulation 15.5" target face
- Concave segment holes
- Eliminate score button
- Missed darts catch ring
- Battery operated (4 AA not included)
- Double or single bull option, 25/50
- Auto point per dart averaging/01 games
- Quick play buttons for Cricket and 01 games
- Voice prompt for next player/remove darts
- Front mounting for easy hanging
- Missed dart button
- Auto player change
- Auto player ranking
- Single/double in/out option
- Bounce out button
- Adjustable sound button with 3 volume levels
- Cricket and 301 buttons
- Limited 1 year warranty

ACCESSORIES

- 6 Starter darts
- 24 Extra tips
- Pro Score measuring tape
- Dartboard throwline
- Game manual
- Mounting hardware



4 PERSON LCD DISPLAY



EASY TO USE CONTROL PANEL



ULTRA-THIN SPIDER, DURABLE HIGH-IMPACT THERMOPLASTIC SEGMENTS, AND MISSED DARTS CATCH RING



BILINGUAL
HABLO ESPAÑOL



VIPER
777

ELECTRONIC 42-0000

Begin your darts journey with one of the best-selling electronic dartboards: the Viper® 777. Tournament quality thermal resin segments withstand even the hardest throws. The 777 features 43 dart games, including Cricket and 301, and over 320 scoring options and variations to assure that you'll never run out of ways to put your darting skills on display. A bilingual voice option is configured for English and Spanish. The backlit display allows you to view scores with ease. The scoreboard highlights the per dart scoring average and per round statistics for 01 and Cricket, allowing you to keep track of your improvement.

DIMENSIONS	22.5"L x 19.5"W x 1.56"H
ITEM WEIGHT	6 lbs
NET WEIGHT	22.16 lbs
GROSS WEIGHT	24.46 lbs
NUMBER OF GAMES	43
NUMBER OF OPTIONS	320
NUMBER OF PLAYERS	8
DISPLAY	2-person Cricket/01 LCD display
SPIDER	Ultra-thin
CARTON OF	4

FEATURES

- Regulation 15.5" target face
- Concave segment holes
- 3AA Batteries or optional AC adapter operated (Batteries and adapter not included)
- Single/double in/out for 01 games
- Missed darts catch ring
- Auto player ranking 01 games
- Front mounting for easy hanging
- Bounce out button
- Ultra thin spider
- Customizable handicap feature
- Adjustable volume with 4 levels
- Auto player change
- Cricket quick key
- Eliminate score button
- Bilingual (English and Spanish)
- Limited 1 year warranty

ACCESSORIES

- 6 Starter darts
- 24 Extra tips
- Pro Score measuring tape
- Dartboard throwline
- Game manual
- Mounting hardware



BACKLIT LCD DISPLAY



EASY TO USE CONTROL PANEL

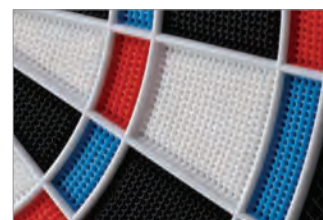

ULTRA-THIN SPIDER, DURABLE HIGH-IMPACT THERMOPLASTIC SEGMENTS, AND MISSED DARTS CATCH RING



MERCURY

ELECTRONIC **42-1053**

Begin darning in a classic style with the Fat Cat® Mercury. With 28 games and 167 scoring options, the Mercury packs enough fun for all your friends and family. The cabinet features built-in slots to store four complete sets of darts and an extra large LCD Cricket scoreboard for easy viewing. The stylish color scheme utilizes bold red and vivid blue on a bright white to ensure you can always see where your darts land.

DIMENSIONS	24.75"L x 20.25"W x 1.5"H
ITEM WEIGHT	9.25 lbs
GROSS WEIGHT	12.5 lbs
NUMBER OF GAMES	28
NUMBER OF OPTIONS	167
NUMBER OF PLAYERS	8
DISPLAY	LCD front and side
SPIDER	Ultra-thin
CARTON OF	1



FEATURES

- Regulation 13" target face
- Concave segment holes
- Segments constructed from durable thermal resin
- Computer play with 5 skill levels
- Cabinet door dart storage
- Limited 90 day warranty

ACCESSORIES

- 6 Starter darts
- 6 Extra tips
- AC power adapter (Input: 100-240V, Output: 5V-1A, UL)
- Game manual
- Mounting hardware



LCD SIDE DISPLAY



EASY TO READ CONTROL PANEL



ULTRA-THIN SPIDER, DURABLE HIGH-IMPACT THERMOPLASTIC SEGMENTS, AND MISSED DARTS CATCH RING



ELECTRONX

ELECTRONIC 42-1054

The Fat Cat® Electronx electronic dartboard features an easy to navigate control panel for fast game play. Surrounding the target face is a large missed dart catch ring, to protect your wall from errant throws while the built in cabinet doors feature convenient dart storage. The Electronx features 34 dart games, including Cricket and 301, and over 183 scoring options and variations to assure that you'll never run out of ways to put your darting skills on display.

DIMENSIONS	24.75"L x 20.25"W x 1.5"H
NET WEIGHT	13.5 lbs
GROSS WEIGHT	14.07 lbs
NUMBER OF GAMES	34
NUMBER OF OPTIONS	183
NUMBER OF PLAYERS	8
DISPLAY	LCD Scoring
SPIDER	Ultra-thin
CARTON OF	1

FEATURES

- Regulation 13" target face
- Concave segment holes
- Computer play with 5 skill levels
- Cabinet door dart storage
- Limited 90 day warranty

ACCESSORIES

- 6 Starter darts
- 6 Extra tips
- AC power adapter (Input: 100-240V, Output: 5V-1A, UL)
- Game manual
- Mounting hardware



LCD DISPLAY AND CONTROL PANEL

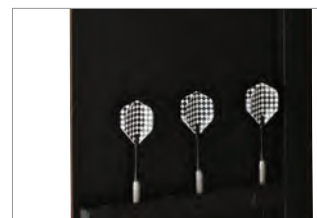

DUAL DART STORAGE RACKS

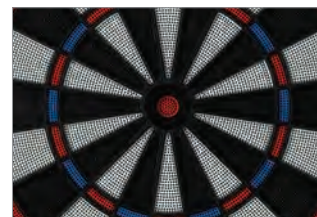

ULTRA-THIN SPIDER, DURABLE HIGH-IMPACT THERMOPLASTIC SEGMENTS, AND MISSED DARTS CATCH RING



NEW PRODUCT

SIRIUS

ELECTRONIC 42-1038

The Sirius is the perfect electronic dartboard for those looking to introduce their family to the game of darts. Features 32 of the most popular games and 201 scoring options.

- DIMENSIONS** 16.6"L x 15.6"W x 0.8"H
- ITEM WEIGHT** 1.85 lbs
- NET WEIGHT** 2.51 lbs
- GROSS WEIGHT** 15.95 lbs
- NUMBER OF GAMES** 32
- NUMBER OF OPTIONS** 200+
- NUMBER OF PLAYERS** 8
- DISPLAY** LED display
- SPIDER** Angled spider
- CARTON OF** 6

FEATURES

- 13.5" Target face with tournament spider
- Precision engineered concave segment holes
- Angled spider
- Extended catch ring
- Game panel listing all the games
- Automatic scoring
- Over 200 scoring options
- Up to 8 players multiplayer, including team play
- Uses 3 AA batteries (not included)

ACCESSORIES

- 6 Starter darts
- 24 Extra tips
- Game manual



EASY TO SEE GAMES MENU



LED SCORER AND CRICKET DISPLAY



727

ELECTRONIC 42-1010

The 727 features 43 dart games, including Cricket and 301, and over 200 scoring options and variations to assure that you'll never run out of family fun! The stylish color scheme is the classic red, green and cream on a dark black that is symbolic of with darting excellence.

- DIMENSIONS** 17.13 "L x 16.38"W x 1"H
- ITEM WEIGHT** 2.8 lbs
- NET WEIGHT** 16.36 lbs
- GROSS WEIGHT** 15.35 lbs
- NUMBER OF GAMES** 43
- NUMBER OF OPTIONS** 200
- NUMBER OF PLAYERS** 8
- DISPLAY** LCD display
- SPIDER** Angled
- CARTON OF** 4

FEATURES

- 13" Target face
- Concave dart holes
- Automatic shut-off
- Missed darts catch ring
- Single/double in/out options for 01 games
- Uses 2 AA batteries (not included)
- Limited 90 day warranty

ACCESSORIES

- 6 Starter darts
- 24 Extra tips
- Game manual



LCD DISPLAY/CONTROL PANEL



EASY TO SEE GAMES MENU



VIPER BLACK **NEW PRODUCT** OBSIDIAN

SELF-HEALING
SISAL BOARD



SISAL FIBER DARTBOARD **42-5000**

The razor-thin wire and bullseye are free of traditional staples that can interfere with your game and cause bounce outs. Prepare for tournament play with the Obsidian, its regulation size of 17.75" (451 mm) matches perfectly with high level event boards.

- DIMENSIONS** 17.75"L x 17.75"W x 1.5"H
- ITEM WEIGHT** 12 lbs
- NET WEIGHT** 48 lbs
- GROSS WEIGHT** 51 lbs
- CARTON OF** 4



FEATURES

- Razor thin spider helps to prevent bounce-outs
- Self-healing board constructed of Kenyan sisal fibers
- Staple-free bullseye for fewer bounce-outs
- Movable low glare number ring extends the board's life
- For use with both steel and soft tip dart sets
- Limited 90 day warranty

ACCESSORIES

- Viper Dartboard Levelers
- Pro Line measuring tape
- Viper Throwline
- Mounting hardware
- Game manual



VIPER DARTBOARD LEVELERS



STAPLE-FREE BULLSEYE



RAZOR THIN SPIDER WIRE

VIPER SLASH

SELF-HEALING
SISAL BOARD



SISAL FIBER DARTBOARD **42-6015**

The razor-thin wire and bullseye are free of traditional staples that can interfere with your game and cause bounce outs. Prepare for tournament play with the Slash, its regulation size of 17.75" (451 mm) matches perfectly with high level event boards.

- DIMENSIONS** 17.75"L x 17.75"W x 1.5"H
- ITEM WEIGHT** 12 lbs
- NET WEIGHT** 48 lbs
- GROSS WEIGHT** 51 lbs
- CARTON OF** 4



FEATURES

- Razor thin spider helps to prevent bounce-outs
- Self-healing board constructed of African sisal fibers
- Staple-free bullseye for fewer bounce-outs
- Movable low glare number ring extends the board's life
- For use with both steel and soft tip dart sets
- Limited 90 day warranty

ACCESSORIES

- 2 MagneDart Holsters
- Viper Dartboard Levelers
- Pro Line measuring tape
- Viper Throwline
- Mounting hardware
- Game manual

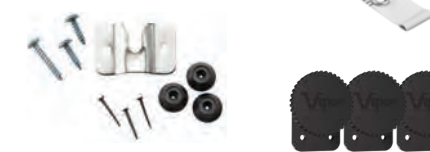

VIPER DARTBOARD LEVELERS

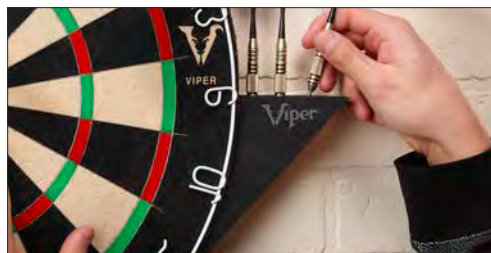

2 MAGNEDART HOLSTERS INCLUDED
(ALSO SOLD SEPARATELY PG. 135)



AIM 360

SELF-HEALING
SISAL BOARD

SISAL FIBER DARTBOARD 42-6008

The Viper® Aim 360 sisal dartboard is a top-performing, 18" dartboard with special aim-enhancing diamond focus points to take your game to the next level.

DIMENSIONS	17.75"L x 17.75"W x 1.5"H
ITEM WEIGHT	12 lbs
NET WEIGHT	48 lbs
GROSS WEIGHT	51 lbs
CARTON OF	4

FEATURES

- Razor thin spider helps to prevent bounce-outs
- Self-healing board constructed of sisal fibers
- Staple-free bullseye for fewer bounce-outs
- Movable low glare number ring extends the board's life
- Movable metal aiming circles
- Diamond aiming point on doubles and triples
- For use with both steel and soft tip dart sets
- Limited 90 day warranty

ACCESSORIES

- 3 Movable aiming circles
- Viper Dartboard Levelers
- Pro Line measuring tape
- Viper Throwline
- Mounting hardware
- Game manual



VIPER DARTBOARD LEVELERS

MOVABLE AIMING CIRCLES



STAPLE-FREE BULLSEYE & RAZOR THIN SPIDER WIRE



DIAMOND AIMING POINTS & MOVABLE AIMING CIRCLE



RAZORBACK

SISAL FIBER DARTBOARD 42-6006

Aim for new heights with the Viper Razorback Sisal Dartboard. This 17.75" professional-quality steel tip dart board is made with high-grade self-healing sisal fibers to ensure it can handle anything you throw at it. The scoring segments are separated by a razor thin spider wire that is 100% staple-free to maximize surface area and prevent bounce-outs and deflections.

DIMENSIONS	17.75"L x 17.75"W x 1.5"H
ITEM WEIGHT	13 lbs
NET WEIGHT	48 lbs
GROSS WEIGHT	51 lbs
CARTON OF	4

FEATURES

- Board constructed of sisal fibers
- Staple-free razor wires for minimal bounce-outs
- Movable low glare number ring extends the board's life
- For use with both steel and soft tip dart sets
- Limited 90 day warranty

ACCESSORIES

- Viper Dartboard Levelers
- Pro Line measuring tape
- Viper Throwline
- Mounting hardware
- Game manual

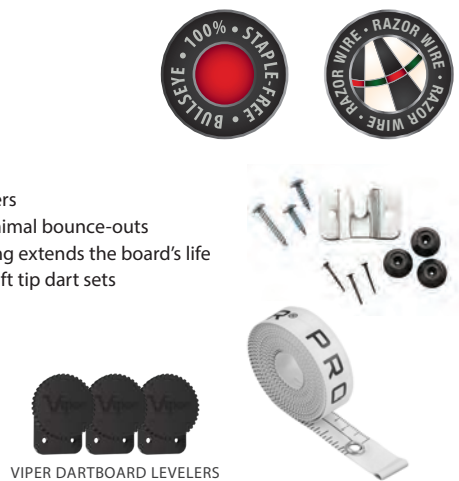

VIPER DARTBOARD LEVELERS



STAPLE-FREE BULLSEYE



STAPLE-FREE RAZOR WIRE



VIPER SHOT KING®

SISAL FIBER DARTBOARD 42-6002

The Viper® Shot King® dartboard features a staple-free bullseye which helps prevent bounce-outs. It's constructed from self-healing sisal fibers compressed together, providing unsurpassed durability.

- DIMENSIONS** 17.75"L x 17.75"W x 1.5"H
- ITEM WEIGHT** 13 lbs
- NET WEIGHT** 48 lbs
- GROSS WEIGHT** 51 lbs
- CARTON OF** 4



FEATURES

- Radial shaped wires increase deflection minimizing bounce-outs
- Board constructed of sisal fibers
- Staple-free bullseye for fewer bounce-outs
- Removable low glare number ring extends the board's life
- For use with both steel and soft tip dart sets

ACCESSORIES

- 2 Sets of steel tip starter darts
- Pro Line measuring tape
- Viper Throwline
- Mounting hardware
- Game manual



STAPLE-FREE BULLSEYE



ROUNDED SHAPED WIRES

VIPER CHROMA

SISAL FIBER DARTBOARD 42-6009

A new modern era of style is accentuated perfectly by the unique colors in the Chroma dartboard. With the latest advances in dartboard technology, the Chroma is a top-tier board. Brand new colorful fibers are self-healing for a longer lifespan and the bullseye is staple free for fewer bounce-outs!

- DIMENSIONS** 17.75"L x 17.75"W x 1.5"H
- ITEM WEIGHT** 12 lbs
- NET WEIGHT** 48 lbs
- GROSS WEIGHT** 51 lbs
- CARTON OF** 4



FEATURES

- Triangular wires to prevent bounce-outs
- Board constructed of sisal fibers
- Staple-free bullseye for fewer bounce-outs
- Movable low glare number ring extends the board's life
- For use with both steel and soft tip dart sets
- Limited 90 day warranty

ACCESSORIES

- Viper Dartboard Levelers
- Pro Line measuring tape
- Viper Throwline
- Mounting hardware
- Game manual



VIPER DARTBOARD LEVELERS



STAPLE-FREE BULLSEYE



TRIANGLE SPIDER WIRE



VIPER LEAGUE

SISAL FIBER DARTBOARD 42-6012

Become a darting ace with the Viper® League sisal dartboard! The League also features galvanized steel wire spider. This gives the spider great durability and strength to last the life of the board. These wires are radial, further reducing your chance of a bounce-out, boosting your average score per dart as they slide off the wire and into the board.

DIMENSIONS	17.75"L x 17.75"W x 1.5"H
ITEM WEIGHT	12.5 lbs
NET WEIGHT	48 lbs
GROSS WEIGHT	51 lbs
CARTON OF	4

FEATURES

- Radial shaped wires to prevent bounce-outs
- Self-healing board constructed of sisal fibers
- Staple-free bullseye for fewer bounce-outs
- Removable low glare number ring extends the board's life
- For use with both steel and soft tip dart sets

ACCESSORIES

- Pro Line measuring tape
- Viper Throwline
- Mounting hardware
- Game manual



STAPLE-FREE BULLSEYE



RADIAL WIRES

VIPER LEAGUE PRO

SISAL FIBER DARTBOARD 42-6011

The League Pro is a fantastic board for those who are looking to complete their gameroom. The dartboard comes with a Cricket scoreboard with chalk and eraser, one complete set of steel tip darts, game manual, and mounting hardware.

DIMENSIONS	17.75"L x 17.75"W x 1.5"H
ITEM WEIGHT	13 lbs
NET WEIGHT	48 lbs
GROSS WEIGHT	51 lbs
CARTON OF	4

FEATURES

- Radial shaped wires to prevent bounce-outs
- Self-healing board constructed of sisal fibers
- Staple-free bullseye for fewer bounce-outs
- Removable low glare number ring extends the board's life
- For use with both steel and soft tip dart sets

ACCESSORIES

- Cricket '01 chalkboard with chalk and eraser
- One set of steel tip starter darts
- Pro Line measuring tape
- Viper Throwline
- Mounting hardware
- Game manual



STAPLE-FREE BULLSEYE

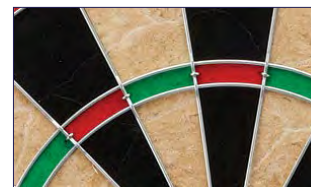

RADIAL SHAPED WIRES



VIPER DEAD-ON

SISAL FIBER DARTBOARD 42-6004

Begin your darting game right with the Viper® Dead-On sisal dartboard! These sisal dartboards will last years longer than their old school wood or paper counterparts. The Dead-On dartboard features a 100% staple-free bullseye and a triangular shaped wire spider. This greatly reduces your chance of a bounce-out occurring while you shoot for a bullseye.

DIMENSIONS	17.75" L x 17.75" W x 1.5" H
ITEM WEIGHT	12 lbs
NET WEIGHT	48 lbs
GROSS WEIGHT	51 lbs
CARTON OF	4

FEATURES

- Triangular wires to prevent bounce-outs
- Board constructed of sisal fibers
- Staple-free bullseye for fewer bounce-outs
- Movable low glare number ring extends the board's life
- For use with both steel and soft tip dart sets
- Limited 90 day warranty

ACCESSORIES

- Viper Dartboard Levelers
- Pro Line measuring tape
- Viper Throwline
- Mounting hardware
- Game manual

VIPER DARTBOARD LEVELERS



STAPLE-FREE BULLSEYE



TRIANGULAR SHAPED WIRES

VIPER DOUBLE PLAY

FIBER DARTBOARD 42-6014

Bring home the fun of darts in addition to a whole new game experience with the Viper® Double Play dartboard, for use with steel-tip and soft-tip darts! This board is sure to bring hours of high-flying fun to your game room, and will certainly turn heads with its distinctive and bright colors.

DIMENSIONS	17.75" L x 17.75" W x 0.9" H
ITEM WEIGHT	5.6 lbs
NET WEIGHT	7.6 lbs
GROSS WEIGHT	41.9 lbs
CARTON OF	6

FEATURES

- 17.75" Regulation size dartboard
- High density coiled paper construction
- Double-faced board allows you to enjoy traditional dart games and all new baseball darts
- Pre-installed hanging bracket

ACCESSORIES

- Two sets of steel tip starter darts
- Game manual

INCLUDES 6 STEEL TIP STARTER DARTS



TWO SIDED DARTBOARD



HANGING BRACKET

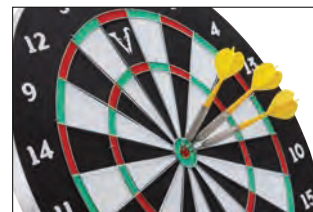

RADIAL SHAPED WIRES



VIPER® HIDEAWAY

STEEL TIP CABINET & DARTBOARD 40-0375

Enjoy your dart games in whole new ways and keep it safe with the Viper® Hideaway dartboard cabinet for steel tip darts! This cabinet will complete the look of any game room with a classic matte black traditional finish. The Hideaway has a coated finish meant to absorb the toughest of impacts. The sharp, sleek design will complement most decors and will ensure that your dartboard doesn't clash with your style. The included dartboard is two sided, on one side you can play a traditional game of darts, like 301 or cricket variations. On the other, there is an exciting alternative in baseball darts, meant to emulate America's pastime with this fun take on darts. Your dart room isn't complete until you have a cabinet in which to store it!

OPEN DIMENSIONS	42.5"L x 21"W x 1.5"H
CLOSED DIMENSIONS	21.5"L x 21"W x 2.13"H
INSIDE DIMENSIONS	20.13"L x 20"W x 1.25"H
NET WEIGHT	12.8 lbs
GROSS WEIGHT	15.7 lbs
CARTON OF	1
WARRANTY	Limited 90 day



FEATURES

- Stylish matte black finish
- Upright dart storage
- Two sided dartboard with traditional darts on one side and baseball darts on the other
- Patina bronze hinges
- Magnetic door locks
- Extra thin profile
- Two chalk scoreboards

ACCESSORIES

- Chalk scoreboard Cricket and '01
- Two pieces of chalk & one eraser
- 17.6"H x 17.6"W Two sided, coiled paper dartboard
- Two sets of steel tip starter darts
- Mounting hardware

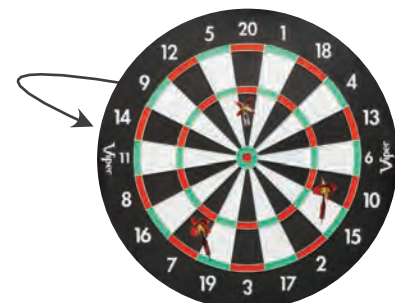

TWO SIDED DARTBOARD



MATTE BLACK FINISH

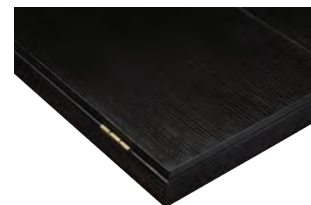

CORNER PRECISION JOINT



CHALK, ERASER, 6 STARTER DARTS AND MOUNTING HARDWARE (INCLUDED)



VIPER STADIUM

STEEL TIP CABINET & DARTBOARD 40-0376

Complete the look of any game room with a classic Viper® Stadium dartboard cabinet with Shot King® dartboard. Don't leave your wall unprotected from errant throws! The Stadium is constructed from wood with a classic walnut finish meant to absorb the toughest of impacts. Underneath the main dartboard area are slots to hold up to six darts upright, to avoid folding the flights, and dry erase marker for the scoreboard, so it doesn't go missing. Included with your dartboard cabinet is a Viper Shot King sisal dartboard, one of our top selling dartboards. Featuring top quality sisal fibers, the Shot King is designed to self heal and last much longer. With a staple free bull and radial spider wires, bounce outs are reduced to a minimum. Your dart room isn't complete until you have a cabinet in which to store it!

OPEN DIMENSIONS	42.5" L x 21" W x 2.5" H
CLOSED DIMENSIONS	21.5" L x 21" W x 3" H
INSIDE DIMENSIONS	20.13" L x 20" W x 2.25" H
NET WEIGHT	20.7 lbs
GROSS WEIGHT	23.2 lbs
CARTON OF	1
WARRANTY	Limited 90 day



CABINET FEATURES

- Stylish mahogany finish
- Upright dart storage
- Patina bronze hinges
- Magnetic door locks
- Extra thin profile
- Two dry erase scoreboards

DARTBOARD FEATURES

- Self healing dartboard
- Removable number ring
- Tournament regulation 17.75" diameter
- Staple free bullseye
- Radial wire spider
- Top quality sisal fibers

ACCESSORIES

- Dry erase Cricket and '01 scoreboards
- Dry erase marker
- Shot King® sisal dartboard
- Two sets of steel tip starter darts
- Mounting hardware



MAHOGANY FINISH



CORNER BOX JOINT



DRY-ERASE MARKER, 6 STARTER DARTS AND MOUNTING HARDWARE (INCLUDED)





VIPER VAULT

STEEL TIP CABINET & DARTBOARD 40-0377

Complete the look of any game room with a classic Viper® Vault dartboard cabinet with Shot King® dartboard. The Vault is constructed from wood with a classic walnut finish meant to absorb the toughest of impacts. The magnetic door lock will keep the doors from swinging out and obstructing your rooms, while attached directly onto the doors are dry erase scoreboards for both '01 games and Cricket. The hinges of the Vault's doors feature an antique brass finish to complete the traditional look of this cabinet. Included with your dartboard cabinet is a Viper Shot King sisal dartboard, one of our top selling dartboards. A removable score ring allows you to rotate your board so it wears evenly. The regulation dartboard measures 18" in diameter for a tournament level experience. Your dart room isn't complete until you have a cabinet in which to store it!

OPEN DIMENSIONS	42.5"L x 22"W x 2.5"H
CLOSED DIMENSIONS	21.5"L x 22"W x 3"H
INSIDE DIMENSIONS	20.13"L x 20"W x 2.25"H
NET WEIGHT	21.2 lbs
GROSS WEIGHT	23.6 lbs
CARTON OF	1
WARRANTY	Limited 90 day



CABINET FEATURES

- Stylish mahogany finish
- Upright dart storage
- Arched doors
- Patina bronze hinges
- Magnetic door locks
- Extra thin profile
- Two dry erase scoreboards

DARTBOARD FEATURES

- Self healing dartboard
- Removable number ring
- Tournament regulation 17.75" diameter
- Staple free bullseye
- Radial wire spider
- Top quality sisal fibers

ACCESSORIES

- Dry erase Cricket and '01 scoreboards
- Dry erase marker
- Shot King® sisal dartboard
- Two sets of steel tip starter darts
- Mounting hardware



MAHOGANY FINISH



CORNER BOX JOINT



DRY-ERASE MARKER, 6 STARTER DARTS AND MOUNTING HARDWARE (INCLUDED)



VIPER® VAULT DELUXE

STEEL TIP CABINET **40-0380**

Complete the look of any game room with a classic Viper® Vault Deluxe dartboard cabinet. Don't leave your wall unprotected from errant throws! The Vault Deluxe is constructed from wood with a classic walnut finish meant to absorb the toughest of impacts. The sharp, sleek design will complement most decors and will ensure that your dartboard doesn't clash with your style. The Vault Deluxe has tons of features to make it the best cabinet for your needs! The magnetic door lock will keep the doors from swinging out and obstructing your rooms, while attached directly onto the doors is a full size Pro Score Electronic Scoreboard, programmed with 40 games and over 600 options. The hinges of the Vault's doors feature an antique brass finish to complete the traditional look of this cabinet. Underneath the main dartboard area are slots to hold up to six darts upright, to avoid folding the flights. Your dart room isn't complete until you have a cabinet in which to store it!

OPEN DIMENSIONS	42.5"L x 21"W x 1.5"H
CLOSED DIMENSIONS	21.5"L x 21"W x 2.13"H
INSIDE DIMENSIONS	20.13"L x 20"W x 1.25"H
NET WEIGHT	12.4 lbs
CARTON OF	1
WARRANTY	Limited 90 day



FEATURES

- Stylish walnut finish
- Patina bronze hinges
- Magnetic door locks
- Preinstalled dartboard hanging bracket
- Dry-erase scoreboard Cricket & '01
- Proscore LCD backlit electronic scorer with 40 games & over 600 options

ACCESSORIES

- Dry-erase scoreboard
- Dry-erase marker
- Proscore LCD scoreboard
- Mounting hardware

DARTBOARD & DARTS NOT INCLUDED



INCLUDES PROSCORE LCD SCOREBOARD, DRY-ERASE SCOREBOARD & MARKER



WALNUT FINISH



PROSCORE ATTACHED TO DOOR



CORNER PRECISION JOINT



VIPER NEW PRODUCT

VAULT DELUXE

STEEL TIP CABINET & DARTBOARD **40-0381**

This ready-to-play dartboard set includes the Viper® Vault dartboard cabinet with Shot King® steel tip dartboard. The Vault dart board cabinet includes two dry erase scoreboards, a standard black one and the Viper Illumiscore. The Illumiscore dart scoreboard lights up so you'll always be able to keep track of your score, even in dimly lit rooms. It's an eye-catching addition to any darting setup. The included Shot King dartboard is a regulation-size 17.75" steel tip dart board made with sisal fibers to last for hours of fun. It features a moveable number ring, allowing you to rotate the board so you can get the most out of it. This set includes the Viper Vault dartboard cabinet, Shot King sisal dartboard, the Illumiscore Scoreboard, a black dry erase scoreboard, two sets of starter darts, a throw line, and a measuring tape.

OPEN DIMENSIONS	42.5"L x 21"W x 1.5"H
CLOSED DIMENSIONS	21.5"L x 21"W x 2.13"H
INSIDE DIMENSIONS	20.13"L x 20"W x 1.25"H
NET WEIGHT	12.4 lbs
CARTON OF	1
WARRANTY	Limited 90 day



CABINET FEATURES

- Stylish walnut finish
- Patina bronze hinges
- Magnetic door locks
- Preinstalled dartboard hanging bracket
- Dry-erase Cricket & '01 scoreboard
- Illumiscore light-up scoreboard

DARTBOARD FEATURES

- Self healing dartboard
- Removable number ring
- Tournament regulation 17.75" diameter
- Staple free bullseye
- Radial wire spider
- Top quality sisal fibers

ACCESSORIES

- Shot King sisal dartboard
- Two sets of steel tip starter darts
- Dry-erase Cricket & '01 scoreboard
- Illumiscore light-up scoreboard
- Pink and green paint markers
- Cloth eraser
- Pro Line measuring tape
- Dartboard throwline
- Mounting hardware



WALNUT FINISH



CORNER PRECISION JOINT





VIPER HUDSON ALL-IN-ONE DART CENTER



MAHOGANY FINISH

CABINET & DARTBOARD

40-0219

CABINET ONLY

40-0262

NEW BLACK FINISH

CABINET & DARTBOARD

40-0202

CABINET ONLY

40-0273

Complete your game room with an all-inclusive dart cabinet bundle. Everything you'll need to get started playing darts is contained in the Viper® Hudson All-In-One Dart Center! The centerpiece of your dart experience is of course the dartboard. The Hudson bundle includes a Viper Shot King® dartboard, giving you the excellence in quality you've come to expect from Viper.

OPEN DIMENSIONS 41.5"L x 23.25"W x 3.5"H

CLOSED DIMENSIONS 23.25"L x 21.25"W x 3.13"H

INSIDE DIMENSIONS 20"L x 20"W x 2.13"H

NET WEIGHT 40-0219 21 lbs

NET WEIGHT 40-0262 10 lbs

GROSS WEIGHT 40-0219 26 lbs

GROSS WEIGHT 40-0262 13 lbs

CARTON OF 1

WARRANTY Limited 90 day



BLACK FINISH



MAHOGANY FINISH

FEATURES

- Tournament sisal dartboard in a pine cabinet
- Sisal fiber dartboard with removable number ring
- Staple-free bullseye
- Self-closing brushed nickel hinges
- Box joint construction
- Black felt backing

DARTBOARD FEATURES

- Self healing dartboard
- Removable number ring
- Tournament regulation 17.75" diameter
- Staple free bullseye
- Radial wire spider
- Top quality sisal fibers

ACCESSORIES

- Dry erase Cricket '01, best dart finish & outchart boards
- Dry erase marker
- Shot King sisal dartboard
- Two sets of steel tip starter darts
- Game manual
- Mounting hardware



BOX JOINTED CORNERS



DRY-ERASE MARKER, 6 STARTER DARTS AND MOUNTING HARDWARE (INCLUDED)





VIPER[®] METROPOLITAN

SOFT TIP CABINET

- MAHOGANY **40-0401**
- CINNAMON **40-0404**
- ESPRESSO **40-0408**

Bring a dart board into your game room, and keep it safe with a classic style with the Viper[®] Metropolitan dartboard cabinet for soft tip darts! This cabinet will complete the look of your game room with one of four traditional finishes. The sharp, sleek design will accent most decors and is an elegant solution to electronic boards that may clash with you thoughtfully put together rooms. Superior construction begins with solid pine wood fastened together with box joints for unsurpassed durability and sturdiness. Your dart room isn't complete until you have a cabinet for your dartboard!

OPEN DIMENSIONS	49.5"L x 38.5"W x 3.5"H
CLOSED DIMENSIONS	38.5"L x 25.25"W x 3.63"H
INSIDE DIMENSIONS	31"L x 24"W x 2"H
INSIDE STORAGE DIMENSIONS	24"L x 5.5"W x 2"H
NET WEIGHT	20 lbs
GROSS WEIGHT	25 lbs
CARTON OF	1
WARRANTY	Limited 90 day



FEATURES

- Brushed nickel self closing hinges
- Holds most soft tip dartboards
- Box joint construction
- Made of solid pine
- Lower storage
- Black felt backing

ACCESSORIES

- Mounting hardware
- Removable dart caddy

DARTBOARD AND ACCESSORIES NOT INCLUDED



CINNAMON FINISH



MAHOGANY FINISH



MOUNTING HARDWARE (INCLUDED)



CORNER BOX JOINT



ESPRESSO FINISH



VIPER[®] REMOVABLE DART CADDY (INCLUDED)



METROPOLITAN

STEEL TIP CABINET

- OAK **40-0402**
- MAHOGANY **40-0403**
- CINNAMON **40-0405**
- ESPRESSO **40-0407**

Bring a dart board into your game room, and keep it safe with a classic style with the Viper® Metropolitan dartboard cabinet for steel tip darts! This cabinet will complete the look of your game room with one of four traditional finishes. Underneath the main dartboard area is a compartment for dart and accessory storage, best achieved with our dart caddy available from Viper. Your dart room isn't complete until you have a cabinet for your dartboard!

- OPEN DIMENSIONS** 42"L x 27.5"W x 3.5"H
- CLOSED DIMENSIONS** 27.5"L x 21.25"W x 3.13"H
- INSIDE DIMENSIONS** 20"L x 20"W x 2"H
- INSIDE STORAGE DIMENSIONS** 20"L x 7"W x 2"H
- NET WEIGHT** 12 lbs
- GROSS WEIGHT** 16 lbs
- CARTON OF** 1
- WARRANTY** Limited 90 day



FEATURES

- Brushed nickel self closing hinges
- Holds most steel tip dartboards
- Made of solid pine with box joint construction
- Lower storage
- Black felt backing

ACCESSORIES

- Mounting hardware
- Dart and accessory holder
- Dry erase Cricket '01, best dart finish & outchart boards
- Dry erase marker

DARTBOARD AND ACCESSORIES NOT INCLUDED



VIPER® REMOVABLE DART CADDY (INCLUDED)



OAK FINISH



MAHOGANY FINISH



CINNAMON FINISH



ESPRESSO FINISH



CINNAMON FINISH CORNER BOX JOINT



DRY-ERASE MARKER AND MOUNTING HARDWARE (INCLUDED)



VIPER STEADFAST



DARTBOARD BACKBOARD SET 41-0628

Complete your dartboard experience with the Viper® Steadfast dartboard backboard display. Featuring easy installation and an expansive coverage, the Steadfast protects your vulnerable wall from errant dart throws. Finally, the cabinet door doubles as a chalk scoreboard, with high-definition graphics printed directly onto the black finish.

- CLOSED DIMENSIONS** 29"L x 21.13"W x 1.88"H
- OPEN DIMENSIONS** 38"L x 21.13"W x 1.88"H
- STORAGE DIMENSIONS** 20"L x 8"W x 1.25"H
- NET WEIGHT** 17.5 lbs
- CARTON OF** 1

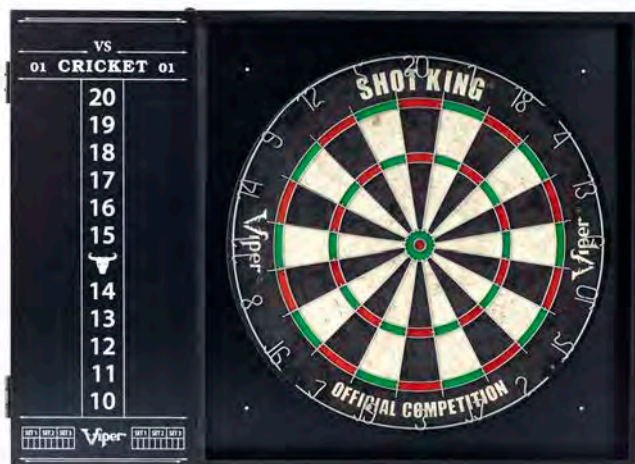

FEATURES

- Stylish black finish
- Patina bronze hinges
- Extra thin profile
- Upright storage for 4 sets of darts
- Accessory storage pocket
- Cricket/01 chalk scoreboard
- Fits all sisal and some soft tip dart boards
- Magnetic door lock

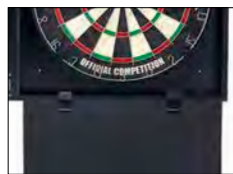

CLIP-ON WALL SHIELD EXTENSION



PRO LINE MEASURING TAPE, CHALK, ERASER & MOUNTING HARDWARE (INCLUDED)



ACCESSORIES

- Shot King® dartboard & 6 Darts (see pg. 114)
- Clip-on EVA wall extension
- Pro Line measuring tape
- Chalk & eraser
- Mounting hardware
- Chalk and eraser

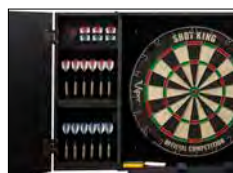

DART AND ACCESSORY STORAGE

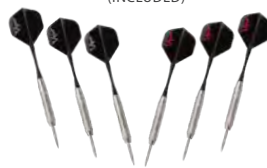

6 SHOT KING DARTS (INCLUDED)

EXTRA ACCESSORIES NOT INCLUDED

VIPER RESOLUTE

DARTBOARD BACKBOARD 41-0627

Protect your wall from wild and errant dart throws with the Viper® Resolute dartboard backboard. The unique shape and deep black finish complements most decors and will add an air of importance to your dartboard display. The Resolute features two built in Cricket scoreboards, with pre-drilled dart storage holes along the bottom of the scoreboards.

- DIMENSIONS** 32.38"L x 20.38"W x 1.88"H
- NET WEIGHT** 5.9 lbs
- CARTON OF** 1



FEATURES

- Stylish black finish
- Extra thin profile
- Upright storage for 2 sets of darts
- 2 Cricket/01 dry-erase scoreboard
- Fits all sisal and some soft tip dart boards
- Pre-assembled mounting bracket

ACCESSORIES

- Mounting hardware
 - Dry-erase marker
 - Clip-on EVA wall extension
- DARTBOARD NOT INCLUDED

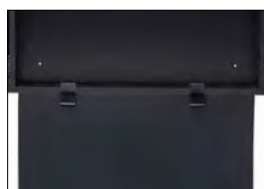

CLIP-ON WALL SHIELD EXTENSION (INCLUDED)



DRY-ERASE MARKER (INCLUDED)



MOUNTING HARDWARE (INCLUDED)



VIPER

DARTBOARD BACKBOARD

BACKBOARD **41-0602**

This backboard protects the surrounding wall space from dents and marks caused by stray darts, and prevents extra wear and tear to steel tip darts points.

- DIMENSIONS** 29"L x 29"W x 1"H
- GROSS WEIGHT** 12 lbs
- NET WEIGHT** 8.7 lbs
- CARTON OF** 1

FEATURES

- 1" Frame with mahogany finish
- Black felt backing
- Fits all sisal and most soft tip dart boards

ACCESSORIES

- Mounting hardware

DARTBOARD NOT INCLUDED



MOUNTING HARDWARE (INCLUDED)



VIPER

CHAMPIONSHIP BACKBOARD SET

BACKBOARD **41-0605**

The Championship Backboard Set protects surrounding wall space from dents and marks caused by stray darts. The convenient side panel holds four complete sets of darts and accessories.

- BACKBOARD DIMENSIONS** 29"L x 29"W x 1"H
- SIDE PANEL DIMENSIONS** 23.5 "L x 14.25"W x 1"H
- GROSS WEIGHT** 20 lbs
- CARTON OF** 1

FEATURES

- 1" Frame with a mahogany finish
- Black felt backing
- 1 Panel with dry erase Cricket '01 scoreboard
- 1 Panel with removable flight pouch
- Holds 4 complete sets of darts
- Fits all sisal and most soft tip dart boards

ACCESSORIES

- Mounting hardware
 - Dry erase marker
- DARTBOARD AND ACCESSORIES NOT INCLUDED



DRY-ERASE MARKER AND MOUNTING HARDWARE (INCLUDED)

VIPER **NEW PRODUCT**

DEAD-ON PROFESSIONAL DARTBOARD CENTER

SURROUND & DARTBOARD SET **42-9051**

This ready-to-play dartboard set includes the Viper Dead-On Dartboard and the Viper Guardian Dartboard Surround, black.

- DIMENSIONS** 27"L x 27"W x 1"H
- GROSS WEIGHT** 14 lbs
- NET WEIGHT** 12.5 lbs
- CARTON OF** 1

FEATURES

- Ultimate protection of your wall from errant throws
- Durable one-inch thick high-density polyshield foam to endure heavy use
- Expansive 2.7 ft² of wall defense
- Compression fit: form-fitting design holds tightly to the board with no mounting hardware required
- Removable number ring
- Tournament regulation 17.75" diameter
- Staple free bullseye
- Triangular wire spider

INCLUDES

- Dead-On sisal dartboard
- Guardian dartboard surround
- Two sets of steel tip starter darts
- Dartboard levelers
- Dartboard throwline
- Pro Line measuring tape
- Mounting hardware



VIPER **NEW PRODUCT**

RAZORBACK PROFESSIONAL DARTBOARD CENTER

SURROUND & DARTBOARD SET **42-9052**

This ready-to-play dartboard set includes the Viper Razorback Dartboard and the Viper Guardian Dartboard Surround, black.

- DIMENSIONS** 27"L x 27"W x 1"H
- GROSS WEIGHT** 14 lbs
- NET WEIGHT** 12.5 lbs
- CARTON OF** 1

FEATURES

- Ultimate protection of your wall from errant throws
- Durable one-inch thick high-density polyshield foam to endure heavy use
- Expansive 2.7 ft² of wall defense
- Compression fit: form-fitting design holds tightly to the board with no mounting hardware required
- Removable number ring
- Tournament regulation 17.75" diameter
- Staple free bullseye
- Razor-thin wire spider

INCLUDES

- Razorback sisal dartboard
- Guardian dartboard surround
- Two sets of steel tip starter darts
- Dartboard levelers
- Dartboard throwline
- Pro Line measuring tape
- Mounting hardware





VIPER GUARDIAN



DARTBOARD SURROUND

BLACK	41-0615-01
RED	41-0615-02
NEW ROYAL BLUE	41-0615-03
NEW PURPLE	41-0615-06
NEW PINK	41-0615-12
NEW ORANGE	41-0615-21
NEW PEACOCK	41-0615-22

This stylish polyshield foam surround requires no installation tools and no assembly, simply fit the surround around the board for a perfect fit! This tough and durable defender will stand up to the most wicked throws, should an errant dart slip by.

SURROUND DIMENSIONS	25"L x 25"W x 1.25"H
CARTON DIMENSIONS	27.9"L x 27.9"W x 1.88"H
GROSS WEIGHT	3.3 lbs
NET WEIGHT	4 lbs
CARTON OF	6

FEATURES

- Ultimate protection of your wall from errant throws
- Durable one-inch thick high-density polyshield foam to endure heavy use
- Expansive 2.7 ft² of wall defense
- Compression fit: form-fitting design holds tightly to the board with no mounting hardware required

DARTBOARD NOT INCLUDED



VIPER WALL DEFENDER

NEW PRODUCT

CORK DARTBOARD SURROUND 41-0612-99

Protects surrounding wall space from dents and marks caused by stray darts. The Defender prevents extra wear and tear to steel tip dart points.

SURROUND DIMENSIONS	28.5"L x 28.5"W x 1"H
CARTON DIMENSIONS	20.6"L x 8.7"W x 4.7"H
GROSS WEIGHT	1.5 lbs
NET WEIGHT	1 lbs
CARTON OF	4

FEATURES

- Covers additional 2.8 ft² of wall space
- 1" Thick high-density V-foam keeps darts from falling
- Fits any standard size 17.75" bristle dartboard
- Attractive cork surface minimizes signs of wear
- Compression fit: form-fitting design holds tightly to the board with no mounting hardware required

DARTBOARD NOT INCLUDED



FOUR-PART PUZZLE PIECE DESIGN FOR EASY INSTALLATION



Sets up in seconds, no tools needed.

VIPER **NEW PRODUCT**

WALL DEFENDER II

CORK DARTBOARD SURROUND 41-0613-99

Protects surrounding wall space from dents and marks caused by stray darts. The Defender II prevents extra wear and tear to steel tip dart points.

SURROUND DIMENSIONS	28.25"L x 28.25"W x 1"H
CARTON DIMENSIONS	16.75"L x 16.75"W x 4.5"H
GROSS WEIGHT	2.1 lbs
NET WEIGHT	1.5 lbs
CARTON OF	6



FOUR-PART PUZZLE
PIECE DESIGN FOR
EASY INSTALLATION

FEATURES

- Covers additional 3.8 square feet of wall space
- Fits any standard size 18" bristle dartboard
- Attractive velvet surface minimizes signs of wear
- Compression fit: form-fitting design holds tightly to the board with no mounting hardware required
- 1" Thick high-density v-foam keeps darts from falling

DARTBOARD NOT INCLUDED

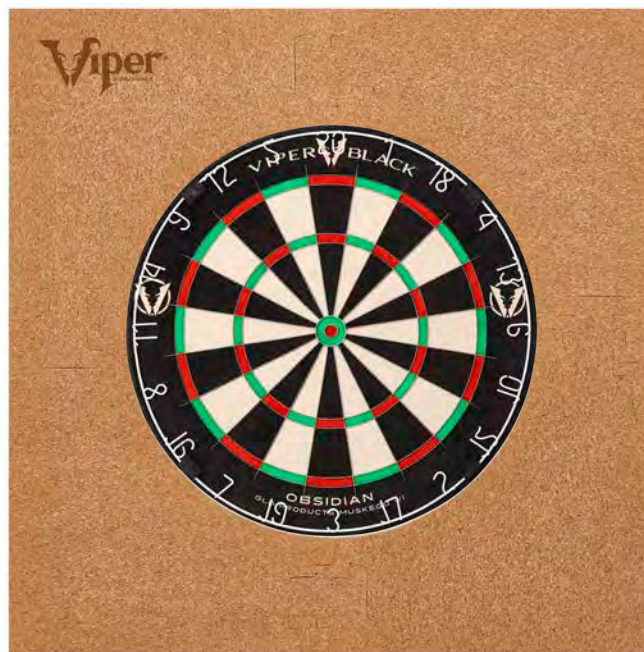

Sets up in seconds, no tools needed.

VIPER **NEW PRODUCT**

WALL DEFENDER III

CORK DARTBOARD SURROUND 41-0614-99

The extended profile of the Defender III covers an amazing 8.2 square feet! Take the guesswork out of deciding which board to purchase, as this surrounding defender will fit perfectly with any regulation sized sisal dartboard!

SURROUND DIMENSIONS	45"L x 32"W x 1"H
CARTON DIMENSIONS	20"L x 20"W x 7"H
GROSS WEIGHT	1.75 lbs
NET WEIGHT	1.5 lbs
CARTON OF	4



SIX-PART PUZZLE
PIECE DESIGN FOR
EASY INSTALLATION

FEATURES

- Covers additional 8.2 square feet of wall space
- 1" Thick high-density V-foam keeps darts from falling
- Fits any standard size 18" bristle dartboard
- Attractive velvet surface minimizes signs of wear
- Compression fit: form-fitting design holds tightly to the board with no mounting hardware required

DARTBOARD NOT INCLUDED

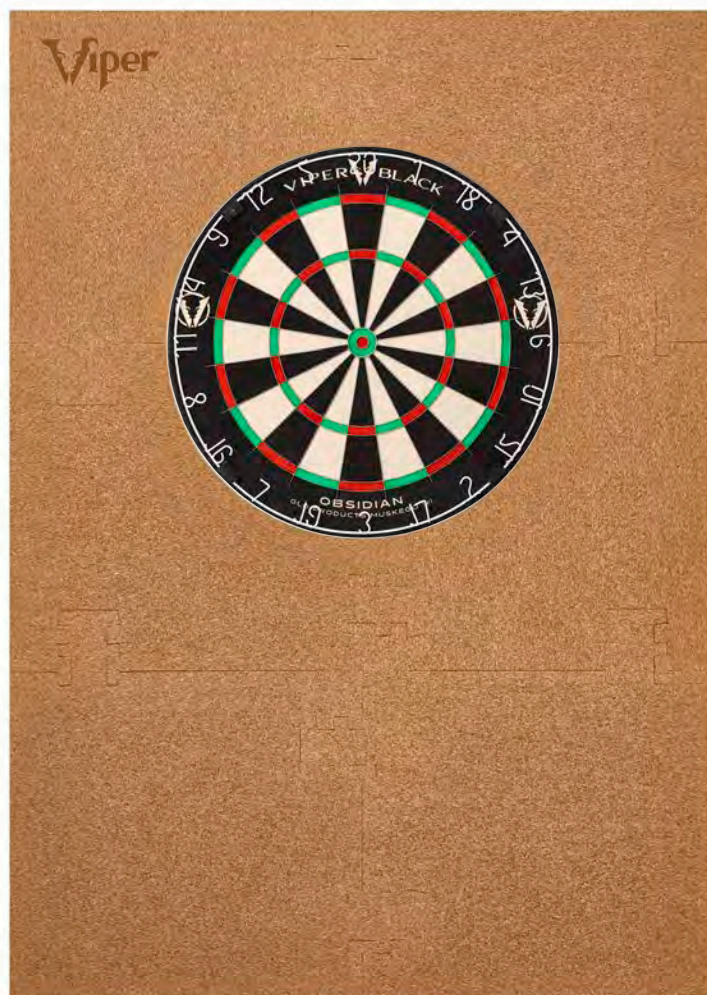

Sets up in seconds, no tools needed.



WALL DEFENDER

DARTBOARD SURROUND 41-0612

Protects surrounding wall space from dents and marks caused by stray darts. The Defender prevents extra wear and tear to steel tip dart points.

SURROUND DIMENSIONS	28.5"L x 28.5"W x 1"H
CARTON DIMENSIONS	20.5"L x 8.5"W x 4.5"H
GROSS WEIGHT	1.5 lbs
NET WEIGHT	1 lbs
CARTON OF	4



FOUR-PART PUZZLE PIECE DESIGN FOR EASY INSTALLATION



Sets up in seconds, no tools needed.

FEATURES

- Covers additional 2.8 ft² of wall space
- 1" Thick high-density V-foam keeps darts from falling
- Fits any standard size 17.75" bristle dartboard
- Attractive velvet surface minimizes signs of wear
- Compression fit: form-fitting design holds tightly to the board with no mounting hardware required

DARTBOARD & DARTS NOT INCLUDED



REVERSIBLE SIDES:
JET BLACK AND VIPER® BRANDED



WALL DEFENDER II

DARTBOARD SURROUND 41-0613

Protects surrounding wall space from dents and marks caused by stray darts. The Defender II prevents extra wear and tear to steel tip dart points.

SURROUND DIMENSIONS	28.25"L x 28.25"W x 1"H
CARTON DIMENSIONS	16.75"L x 16.75"W x 4.5"H
GROSS WEIGHT	2.1 lbs
NET WEIGHT	1.5 lbs
CARTON OF	6



FOUR-PART PUZZLE PIECE DESIGN FOR EASY INSTALLATION



Sets up in seconds, no tools needed.

FEATURES

- Covers additional 3.8 square feet of wall space
- Fits any standard size 18" bristle dartboard
- Attractive velvet surface minimizes signs of wear
- Compression fit: form-fitting design holds tightly to the board with no mounting hardware required
- 1" Thick high-density v-foam keeps darts from falling

DARTBOARD & DARTS NOT INCLUDED



REVERSIBLE SIDES:
JET BLACK AND VIPER® BRANDED

VIPER

WALL DEFENDER III

DARTBOARD SURROUND 41-0614

The extended profile of the Defender III covers an amazing 8.2 square feet! Take the guesswork out of deciding which board to purchase, as this surrounding defender will fit perfectly with any regulation sized sisal dartboard!

SURROUND DIMENSIONS 45"L x 32"W x 1"H

CARTON DIMENSIONS 20"L x 20"W x 7"H

GROSS WEIGHT 1.75 lbs

NET WEIGHT 1.5 lbs

CARTON OF 4

FEATURES

- Covers additional 8.2 square feet of wall space
- 1" Thick high-density V-foam keeps darts from falling
- Fits any standard size 18" bristle dartboard
- Attractive velvet surface minimizes signs of wear
- Compression fit: form-fitting design holds tightly to the board with no mounting hardware required

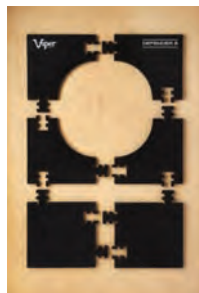

SIX-PART PUZZLE
PIECE DESIGN FOR
EASY INSTALLATION

DARTBOARD & DARTS NOT INCLUDED



Sets up in seconds, no tools needed.

VIPER

EVA V-FOAM PROTECTIVE BACKBOARD

BACKBOARD 41-0610

The EVA V-Foam Protective Backboard protects surrounding wall space from dents and marks caused by stray darts and prevents extra wear and tear to steel tip dart points.

BACKBOARD DIMENSIONS 27"L x 27"W x .5"H

CARTON DIMENSIONS 28 "L x 28"W x 2"H

GROSS WEIGHT 6 lbs

NET WEIGHT 4 lbs

CARTON OF 1

FEATURES

- Protects walls and surrounding areas from errant throws, also prevents darts from rolling and hiding under furniture
- Made with high density EVA to prevent cracking, warping or peeling
- Can be hung in a diamond or square position to fit into any decor

ACCESSORIES

- Mounting hardware

DARTBOARD, DARTS & FLIGHTS NOT INCLUDED



MOUNTING HARDWARE
(INCLUDED)

MOUNT AS A SQUARE OR DIAMOND



CRICKET SCOREBOARDS



41-0301



LARGE DRY ERASE

41-0310



SMALL DRY ERASE

41-0101



LARGE CHALKBOARD

41-0102

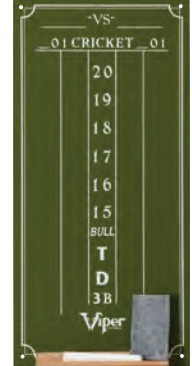

SMALL CHALKBOARD

- LARGE DIMENSIONS** 23.5"L x 15.5"W x 1.13"H
- SMALL DIMENSIONS** 15.38"L x 7.88"W x .13"H
- LARGE NET WEIGHT** 1.55 lbs
- SMALL NET WEIGHT** 0.55 lbs
- CARTON OF** 6

ACCESSORIES

- Dry erase marker
- Mounting hardware

DRY ERASE PEN 37-0115

Available individually



- LARGE DIMENSIONS** 23.5"L x 15.5"W x 1.13"H
- SMALL DIMENSIONS** 15.38"L x 7.88"W x .88"H
- LARGE NET WEIGHT** 1.37 lbs
- SMALL NET WEIGHT** 0.60 lbs
- CARTON OF** 6

ACCESSORIES

- Chalk and eraser
- Mounting hardware



PROSCORE

DIGITAL SCORER 37-0116

- ITEM DIMENSIONS** 10"L x 4.75"W x 1"H
- CARTON DIMENSIONS** 10.25"L x 5"W x 1.5"H
- GROSS WEIGHT** 0.61 lbs
- NET WEIGHT** 0.62 lbs
- CARTON OF** 12

FEATURES

- Add the most convenient innovation of electronic dartboards to your sisal dartboard experience, without giving up the classic tradition!
- With 40 games and 655 options you'll find all of your time-honored favorites, and new experiences as well
- Colossal LCD scoreboard is backlit with sharp red light for higher visibility from the throw line
- A custom handicap options allows you to even out the playing field between pros and novices
- Supports up to 8 player multiplayer. Including computer opponents.
- Includes easy to use mounting hardware for quick installation.

ACCESSORIES

- Mounting hardware
- Powered by 3AA batteries or optional adapter (#42-9987, 100-240V 50-60Hz AC to 5V DC at 1000mA, positive outside to negative center)

DARTBOARD, ADAPTER AND BATTERIES NOT INCLUDED



WALL-MOUNTABLE



MOUNTING HARDWARE (INCLUDED)



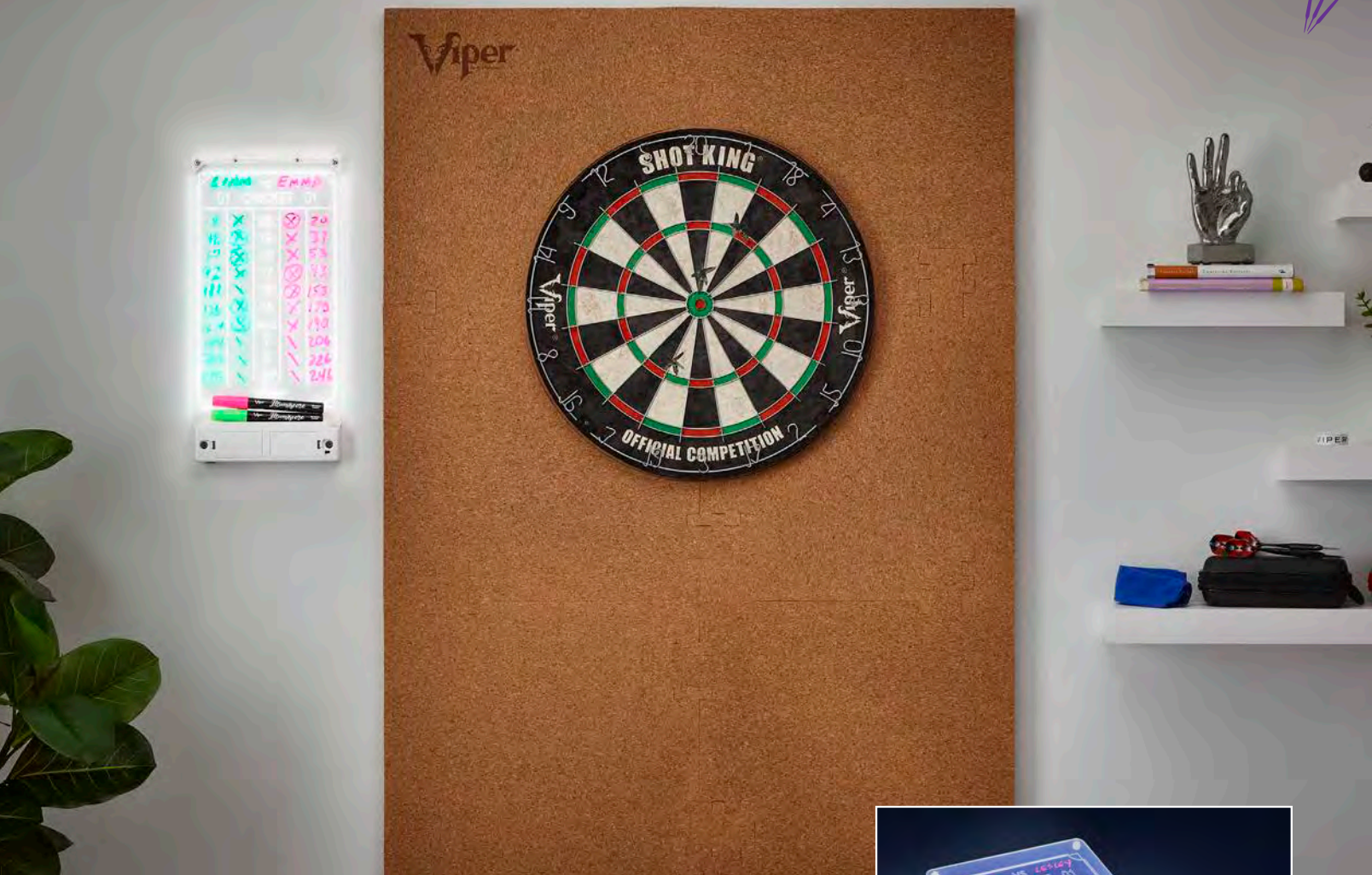

VIPER[®] ILLUMISCORE



SCOREBOARD

BLACK LARGE 41-0402

BLACK SMALL 41-0401

NEW WHITE SMALL 41-0410

Light up your opponents when they see your scores on the Viper[®] Illumiscore Illuminated Dart Scoreboard. The specially designed pencils will glow brightly when the board is lit. Clean up is a breeze, as the board wipes clean after every game.

LARGE DIMENSIONS 19.5"L x 10"W x 1"H

SMALL DIMENSIONS 15.5"L x 7.5"W x 1.25"H

LARGE NET WEIGHT 1.5 lbs

SMALL NET WEIGHT 1.02 lbs

CARTON OF 6

ACCESSORIES

- Instructions for popular dart games
- Pink and green paint markers
- Cloth eraser
- Mounting hardware
- Powered by 4AA batteries or power adapter
- Power adapter (#42-9987, 100-240V 50-60Hz AC to 5V DC at 1000mA, positive outside to negative center)

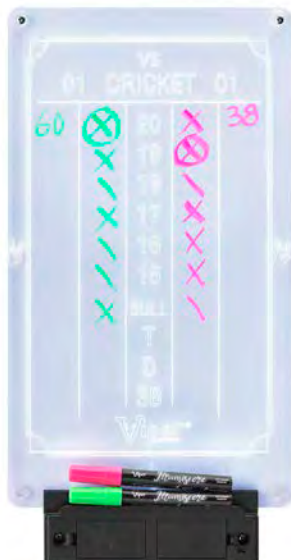

LARGE



SMALL

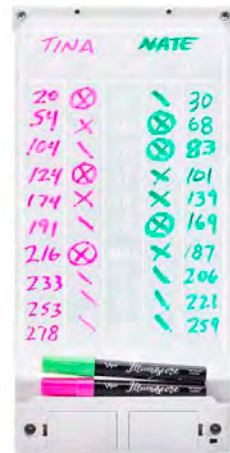

SMALL

BATTERIES, ADAPTER, DARTBOARD, BACKBOARD, DARTS AND ACCESSORIES NOT INCLUDED



SHADOW BUSTER



DARTBOARD ILLUMINATOR **37-0000**

Complete your gameroom with the Shadow Buster overhead dartboard cabinet light. This compact, easy-to-operate illumination system floods your dartboard with light so you can aim that perfect shot every time.

DIMENSIONS	12.99"L x 2.17"W x 1.77"H
NET WEIGHT	0.53 lbs
CARTON OF	1

FEATURES

- Fastens easily to all flat-topped wooden dartboard cabinets with 2.2" deep top
- Adjustable spotlight pods for perfect illumination
- Flips up and out of the way for storage when not in use
- Encourages improved skill, accuracy, and focus
- Flexible power options: requires 4 AA batteries or optional power adapter (#42-9987, 100-240V 50-60Hz AC to 5V DC at 1000mA, positive outside to negative center)

BATTERIES, ADAPTER, CABINET, DARTBOARD, AND ACCESSORIES NOT INCLUDED

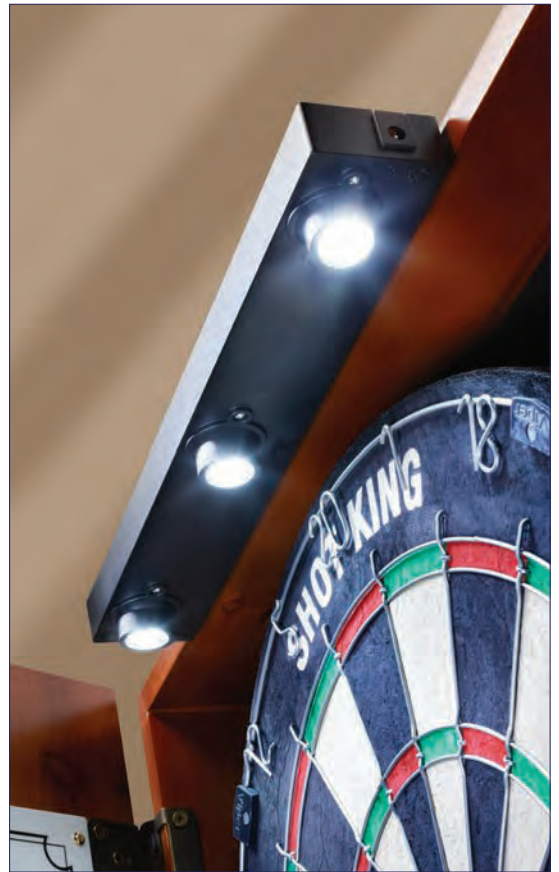

DART CADDY

CINNAMON FINISH	40-0702
MAHOGANY FINISH	40-0703
BLACK FINISH	40-0705

Keep your darts organized and displayed with style! These new dart caddies hold up to 12 darts and include a velvet pouch for accessories.

DIMENSIONS	16"L x 4"W x 0.88"H
NET WEIGHT	1 lbs
GROSS WEIGHT	1.5 lbs
CARTON OF	1

FEATURES

- Solid wood construction
- Holds both steel and soft tip darts
- Includes mounting hardware

DARTS, DARTBOARD, SCOREBOARD, & ACCESSORIES NOT INCLUDED

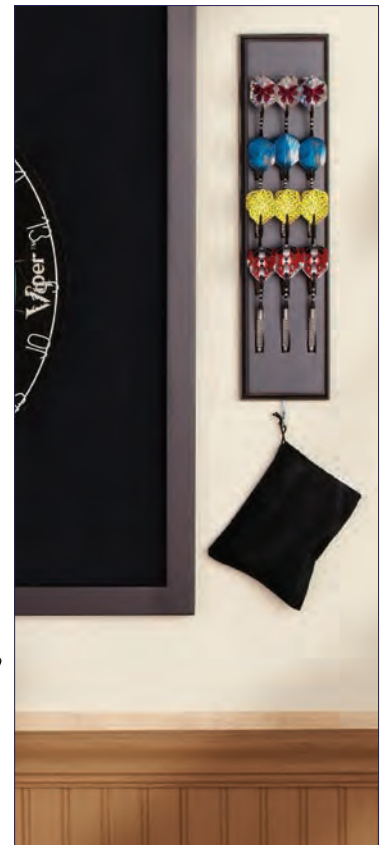



MAGNEDART HOLSTERS

MAGNETIC DART HOLDERS **40-0704**

Magnedart Holsters keep your darts closeby and ready for action. The innovative design is easy to use and snaps right onto compressed sisal dartboards, no tools required. The extra powerful magnets hold tight to the board and ensure your darts are safe and secure.

DIMENSIONS 5"L x 3.5"W x 1.5"H

GROSS WEIGHT 1 lbs

CARTON OF 1

FEATURES

- Keep your darts closeby and ready for action
- Extra powerful magnets hold tight to the board
- Ensures darts are safe and secure
- Easy to use design, no tools required

DARTBOARD & DARTS NOT INCLUDED



DARTBOARD LEVELER KIT

DARTBOARD LEVELERS **37-0177**

Make leveling and securing your dartboard onto the wall quick and simple with the Viper® Dartboard Leveler Kit. This kit is perfect for leveling your dartboard as well as securing it into place for reduced wobble when throwing darts.

FEATURES

- Quick and simple setup
- Levels your dartboard on the wall
- Secures dartboard into place
- Longlasting and reusable when setting up a new dartboard

DARTBOARD, DARTS & SCREWDRIVER NOT INCLUDED

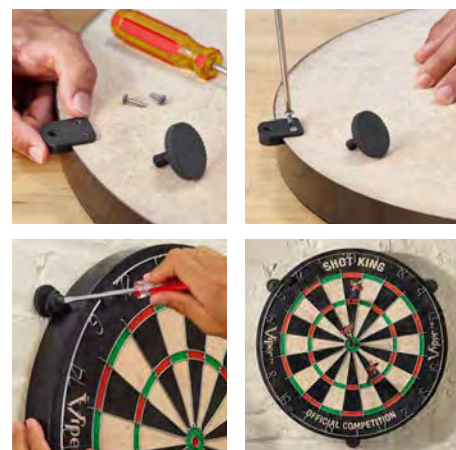

QUICKFIT

DARTBOARD MOUNTING BRACKET **37-9003**

Mount your dartboard quickly, easily, and accurately with the Viper QuickFit Dartboard Mounting Bracket. The QuickFit's track slider system eliminates guesswork when hanging your dart board, providing a durable hold on nearly any wall, cabinet, or backboard so you can play with confidence. The QuickFit dart board mounting system is completely reusable too; when upgrading to a new dart board simply remove and attach it to your new dart board.

FEATURES

- Quick and simple setup
- Levels your dartboard on the wall
- Secures dartboard into place
- Longlasting and reusable when setting up a new dartboard

DARTBOARD & SCREWDRIVER NOT INCLUDED





PRO LINE



THROW LINE MEASURING TAPE 37-0146

Take all the guesswork out of finding the perfect distance for your throw line with the Viper® Pro Line Marker Tape. This convenient tool allows you to mark precisely where your throw line should be in relation to the front of your board. Engineered measurements ensure that your throw line is the correct regulation distance, ready for tournament play! The Pro Line tape is easy to use and requires no tools, simply attach the end of the tape to your board with a dart, find the distance you need and mark it! The tape then folds back into its case for easy storage to any event!

- DIMENSIONS** 2.37"L x 2.37"W x 0.905"H
- GROSS WEIGHT** 0.5 lbs
- CARTON OF** 1



MEASURING DISTANCES		
1	5' 8"	173cm
2	9' 7 1/2"	293cm
3	9' 9 1/4"	299cm

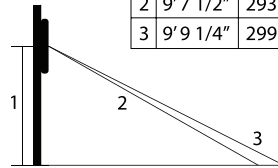

FEATURES

- Verify regulation dartboard distance with ease
- To use: Pin the tab onto the dartboard bullseye, walk until desired throw line distance appears, and place your desired throw line marker
- Finds distance for both steel and soft tip games

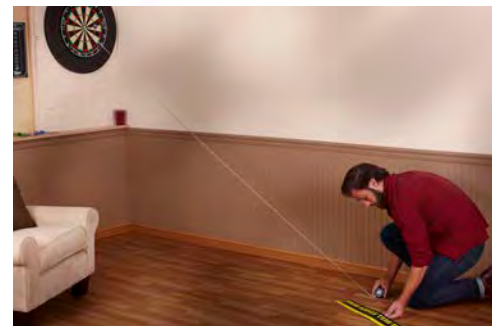

PADDED NON-SLIP VINYL DART MAT



DART MAT 37-0106

- DIMENSIONS** 9'11"L x 24"W x .25"H
- GROSS WEIGHT** 12 lbs
- NET WEIGHT** 7.6 lbs
- CARTON OF** 1

FEATURES

- Embossed line markings for steel tip and soft tip darts
- Protects your floor
- Easily rolls away after use
- Heavy duty .25" thick
- Non-slip

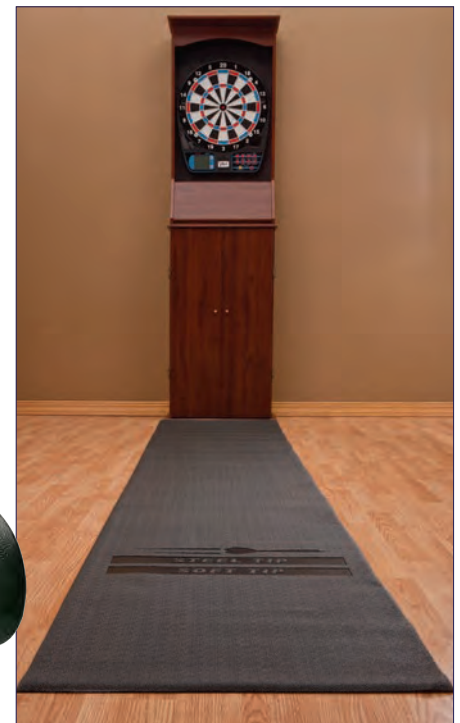



LASER DART LINE

LASER DART LINE 37-0108

The latest high tech innovation in dart throw lines is here with the Viper® Laser Dart Line! The Laser Dart Line projects a concentrated beam of light to indicate where you should be standing. The adjustable laser line allows you to place the line at any height, and you can project it to any distance, perfect for players of both steel tip and soft tip darts. The Viper® Laser Dart Line mounts quickly and easily to the wall or the underside of a dart cabinet.

DIMENSIONS 10"L x 2.25"W x 1.25"H

GROSS WEIGHT 1 lbs

CARTON OF 1

FEATURES

- State of the art laser beam to mark your throw line
- Adjustable laser head locks into place for a precise line
- Adjustable line distance
- Easy to mount onto wall
- Battery operated (4 AA batteries)
- Optional power adapter (#42-9987, 100-240V 50-60Hz AC to 5V DC at 1000mA, positive outside to negative center)

BATTERIES, ADAPTER, CABINET, DARTBOARD AND ACCESSORIES NOT INCLUDED



LASERLITE

MINI LASER DART LINE 37-0025

The convenient Laserlite allows you to place the line directly into your dartboard, there's no messy installation! You can adjust the line to your preferred distance, whether you're setting up the official tournament distance or changing it up for practice. The Viper Laserlite throw line mounts quickly and easily to any of our compatible electronic dart boards, just plug it right in! The throw line uses the power from the dart board for a great cord free look and no extra batteries!

DIMENSIONS 2.88"L x 1.38"W x 1.13"H

GROSS WEIGHT 0.5 lbs

CARTON OF 1

FEATURES

- State of the art laser beam to mark your throw line
- Adjustable laser head locks into place for a precise line
- Customizable line distance
- Plugs directly into compatible dartboards

DARTBOARD NOT INCLUDED

COMPATIBLE DARTBOARDS:
ORION #42-1036, 800 #42-1034,
SOLAR BLAST #42-1021

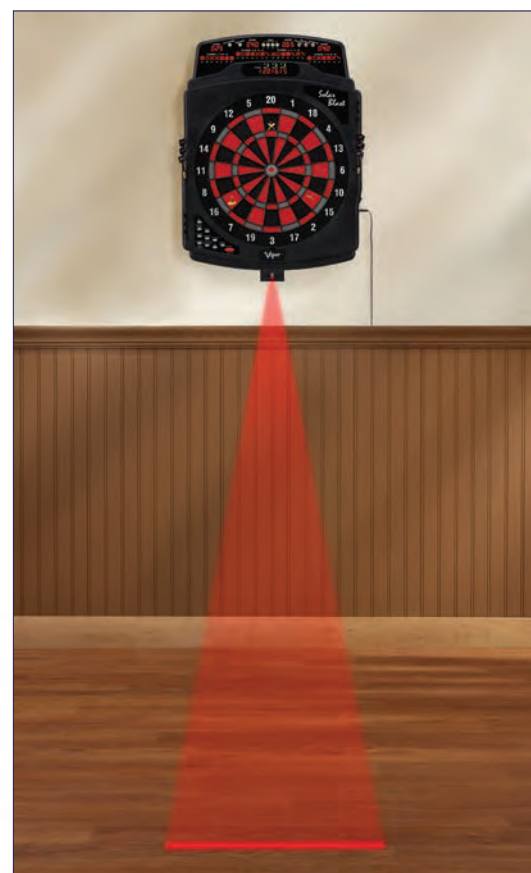



“THE BULL STARTS HERE” THROW LINE

37-0125

THROW/TOE LINE MARKER

DIMENSIONS 23.5”L x 3.75”W
WEIGHT 0.6 lbs
CARTON OF 5

The Fat Cat® “The Bull Starts Here” throw line marker helps keep player’s toes behind the line. A precisely engineered Axis Rectifier Scale helps you adjust your stance consistently throw after throw. The classic design with impressive visibility helps eliminate foot fouls.



EDGE DART THROW LINE

THROW/TOE LINE MARKER

DIMENSIONS 23.5”L x 3.75”W
WEIGHT 0.6 lbs
CARTON OF 5

Step up your competition! The Viper® Edge throw line marker has a precisely engineered Axis Rectifier Scale helps you adjust your stance consistently throw after throw, running your average even higher. High quality printing and heavy duty resin will stand the test of time, after countless games. The sleek design and elegant sharpness complement a modern décor much better than that old piece of masking tape.



37-0130

NEW



37-0147

NEW



37-0148

NEW



37-0149

NEW



37-0150

NEW



37-0151

BILLIARDS

FERRULE

The ferrule holds the cue tip in place and absorbs the impact of the hit to the cue ball, protecting the shaft.

TIPS

Billiard cue tips are normally made of leather with varying degrees of hardness, curvature, and diameter. Can apply a spin on the cue ball. Tips vary based on purpose of cue i.e. break cue, jump cue, etc. It is glued or screwed to the ferrule.

JOINT

Connection between the cue shaft and the butt. Made of a variety of materials, most commonly used are ABS, brass, or stainless steel.

SHAFT

The shaft is usually made of maple, other hardwoods or fiberglass, and tapered from the tip end back towards the center of the shaft or the collar of the shaft which connects the joint.

BUMPER

The bumper is typically made of rubber, the bumper's purpose is to protect the cue when resting on the ground, or from collisions. Without a bumper, the reverberations of the cue hitting the ball may vibrate more than a cue with a tight, well fitting bumper and the butt may crack over time.

Several of GLD Products cues feature bumpers with a built-in removable scuffer. These are used to reshape the tip, which improves the application of chalk and ball control.

WRAP

Used to enhance grip and provide aesthetic appeal as well as better grip and moisture absorption. Common forms of wraps are leather, Irish linen and nylon.

BUTT CAP

Contains the bulk of the weight of the cue determined by the hardwood used or weights added. The butt is where the use of inlays, rings, and other decorations as well as wraps are used to enhance the look of the cue.





DESPERADO

BILLIARD CUE

Play bold and make a statement with the Desperado billiard cue sticks from Viper®. Fashioned from Canadian maple hardwood to withstand years of use, the Desperado billiard cues stand out from the rest with laser-engraved etchings of sharp designs. These cue sticks feature all the performance-enhancing qualities you've come to expect from exceptional cues. A Le Pro leather tip ensures a solid grip on the ball, reducing miscues. A Pro Taper gives a consistent and comfortable feel across your stroke, and a 100% genuine leather wrap reduces vibration and provides unparalleled grip. The shaft and butt combine with lightweight stainless steel joints to give great feedback on every shot.

- LENGTH** 58"
- JOINT SCREW** 5/16" x 18
- JOINTS** Stainless steel laser etched joint
- WRAP** 100% Genuine leather wrap
- BUTT CAP** ABS printed
- WEIGHT** 18-21 oz. Adjustable weight system
- WARRANTY** Limited lifetime



ADJUSTABLE WEIGHT BOLT SYSTEM



100% GENUINE LEATHER WRAPS

BURNT LASER ENGRAVING WITH ORIGINAL GRAPHICS

WOOD AND ONYX INLAYS WITH STAINLESS STEEL RINGS



BUILT-IN REMOVABLE SCUFFER
Replacement scuffer/bumper on page 163



50-1000 | **FREEDOM** | Acacia forearm/sleeve | Extra 13mm shaft 53-9000 sold separately



50-1002 | **STING** | Canadian Maple forearm/Acacia | Extra 13mm shaft 53-9000 sold separately



50-1006 | **IRON CROSS** | Canadian Maple forearm/Sleeve | Extra 13mm shaft 53-9000 sold separately



50-1007 | **DEATH MARK** | Canadian Maple forearm/Sleeve | Extra 13mm shaft 53-9000 sold separately



NATURALS

BILLIARD CUE

Enhance your game and show off refreshingly quaint beauty with the Naturals billiard cue sticks from Viper®. Fashioned from Canadian maple hardwood to withstand years of use, the Naturals billiard cues stand out from the rest with highly visible, unique wood grains from exotic maples. These cue sticks feature all the performance-enhancing qualities you've come to expect from exceptional cues. A Le Pro leather tip ensures a solid grip on the ball, reducing miscues. A Pro Taper gives a consistent and comfortable feel across your stroke, and a bonded leather wrap reduces vibration and provides a great look for the budget conscious. The shaft and butt combine with lightweight wood to wood joints to give great feedback on every shot, while maintaining a classic look.

- LENGTH** 58"
- JOINT SCREW** 3/8" x 10
- JOINTS** Wood to wood
- WRAP** Leatherette
- BUTT CAP** Logo engraved stainless steel
- WEIGHT** 18-21oz. Adjustable weight system
- WARRANTY** Limited lifetime



ADJUSTABLE WEIGHT BOLT SYSTEM



NON SLIP
LEATHERETTE GRIP

RINGS ARE A COMBINATION OF
EXOTIC WOOD AND EBONY

BUTT SLEEVE AND FOREARM
ARE SPECIFIED EXOTIC WOODS



BUILT-IN REMOVABLE SCUFFER
Replacement scuffer/bumper on page 163



50-0601 | **CHERRYWOOD** | Cherrywood forearm/sleeve | Extra 13mm shaft 53-9001 sold separately



50-0603 | **BIRDSEYE** | Birdseye forearm/sleeve | Extra 13mm shaft 53-9001 sold separately



50-0604 | **ZEBRAWOOD** | Zebrawood forearm/sleeve | Extra 13mm shaft 53-9001 sold separately

VIPER

REVOLUTION

BILLIARD CUE

Enhance your game and make a bold statement with the Revolution billiard cue sticks from Viper® with silicon infused dura-wick cloth. Fashioned from Canadian maple hardwood to withstand years of use, the Revolution billiard cues stand out from the rest, featuring sharp original graphics. These cue sticks feature all the performance-enhancing qualities you've come to expect from exceptional cues. The shaft and butt combine with lightweight stainless steel joints to give great feedback on every shot.

- LENGTH** 58"
- JOINT SCREW** 5/16" x 18
- JOINTS** Stainless steel
- WRAP** Silicone infused dura-wick cloth
- BUTT CAP** Logo engraved ABS imprinted
- WEIGHT** 18-21oz. Adjustable weight system
- WARRANTY** Limited 3 year



ADJUSTABLE WEIGHT BOLT SYSTEM

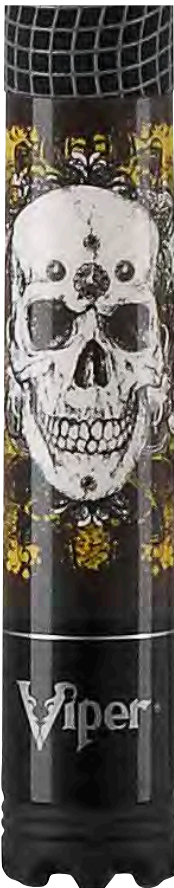

SILICONE INFUSED
DURA-WICK CLOTH WRAP

BOLD ORIGINAL GRAPHICS



BUILT-IN REMOVABLE SCUFFER
Replacement scuffer/bumper
on page 163



50-0202 | RELIC
Stainless steel joint
Hardwood maple forearm/sleeve
Extra 13mm shaft 53-9004 Sold separately

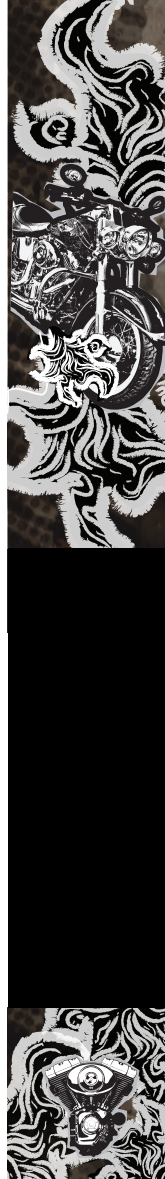

50-0203 | RIDER
Stainless steel joint
Hardwood maple forearm/sleeve
Extra 13mm shaft 53-9004 Sold separately



50-0204 | OUTLAW
Stainless steel joint
Hardwood maple forearm/sleeve
Extra 13mm shaft 53-9004 Sold separately



50-1501 | SPIDER
Stainless steel joint
Hardwood maple forearm/sleeve
Extra 13mm shaft 53-9004 Sold separately

JUNIOR CUE
AVAILABLE
Page 156

VIPER

SINISTER

BILLIARD CUE

Enhance your game and enjoy classic style with the Sinister Billiard Cues from Viper®. Each is fashioned from Canadian maple hardwood, accented with a distinctive tiger stripe grain, to withstand years of use. Each Sinister billiard cue stands out from the rest, featuring unique acrylic inlays. These cue sticks feature all the performance-enhancing qualities you've come to expect from exceptional cues. A Le Pro leather tip ensures a solid grip on the ball, reducing miscues. A Pro Taper gives an even and comfortable feel across your stroke, and finished off with a comfortable Irish linen wrap. The shaft and butt combine with durable ABS joints to give consistent feedback on every shot.

- LENGTH** 58"
- JOINT SCREW** 5/16" x 18
- JOINTS** Stainless steel or ABS
- WRAP** Irish linen or bonded leather
- BUTT CAP** Stainless steel or ABS
- WEIGHT** 18-21oz. Adjustable weight system
- WARRANTY** Limited lifetime



ADJUSTABLE WEIGHT BOLT SYSTEM



ACRYLIC INLAYS

STAINLESS STEEL AND ACRYLIC RINGS



BUILT-IN REMOVABLE SCUFFER
Replacement scuffer/bumper on page 163



50-1077 | STAINLESS STEEL JOINT | Dark Brown Finish and Nickel Plate Inlay | Irish linen wrap | Hardwood maple forearm | Extra 13mm shaft 53-9009 sold separately



50-1250 | STAINLESS STEEL JOINT | Irish linen wrap | Hardwood maple forearm | Extra 13mm shaft 53-9010 sold separately

VIPER SINISTER



50-1252 | STAINLESS STEEL JOINT | Irish linen wrap | Hardwood maple forearm | Extra 13mm shaft 53-9010 sold separately



50-1350 | STAINLESS STEEL JOINT | Irish linen wrap | Hardwood maple forearm | Extra 13mm shaft 53-9010 sold separately



50-1351 | STAINLESS STEEL JOINT | Irish linen wrap | Hardwood maple forearm | Extra 13mm shaft 53-9010 sold separately



50-1352 | STAINLESS STEEL JOINT | Irish linen wrap | Hardwood maple forearm | Extra 13mm shaft 53-9010 sold separately



50-1353 | STAINLESS STEEL JOINT | Irish linen wrap | Hardwood maple forearm | Extra 13mm shaft 53-9010 sold separately



50-1401 | ABS JOINT | Leatherette wrap | Hardwood maple forearm | Stainless steel and acrylic rings | Extra 13mm shaft 53-9007 sold separately



ELEMENTALS

BILLIARD CUE

The Elements are the newest addition to our Viper® line of cues. They are made of a natural ash forearm and a Canadian maple butt. We have paid close attention to the detail of design as well as the wraps. These cues have classy accent rings that show off the various finish. Whether you prefer a lighter or a darker color cue, a heavier or a lighter cue; The Elements line will satisfy.

- LENGTH** 58"
- JOINT SCREW** 5/16" x 10
- JOINTS** Quick release
- WRAP** Bonded leatherette
- BUTT CAP** ABS printed
- WEIGHT** 18-21oz. Adjustable weight system
- WARRANTY** Limited lifetime



ADJUSTABLE WEIGHT BOLT SYSTEM



BONDED LEATHERETTE WRAPS

STAINLESS STEEL RINGS

ASH BUTT AND THROAT

TRADITIONAL OVERLAY PATTERNS



BUILT-IN REMOVABLE SCUFFER

Replacement scuffer/bumper on page 163



50-0851 | **ASH WITH AMBER FINISH FOREARM/SLEEVE** | Quick release | Silver accent rings | Extra 13mm shaft 53-9005 sold separately



50-0852 | **ASH WITH CHERRY FINISH FOREARM/SLEEVE** | Quick release | Silver accent rings | Extra 13mm shaft 53-9005 sold separately



50-0853 | **ASH WITH WOOD GRAIN FOREARM/SLEEVE** | Quick release | Silver accent rings | Extra 13mm shaft 53-9005 sold separately



COLOURS

BILLIARD CUE

Thinking fashion, Viper® incorporated the Colours cues with wraps, both nylon and Irish linen to match the color of the cue. Keeping sight of the need for the 13mm Le Pro tips, Canadian maple pro taper shafts, and stainless steel joints, we added flair by signing the cues with a named water mark. It is attention to detail that makes a fashion statement.

- LENGTH** 58"
- JOINT SCREW** 5/16" x 10
- JOINTS** Stainless steel
- WRAP** Colored Irish linen or nylon
- BUTT CAP** Logo engraved stainless steel
- WEIGHT** 18-21oz. Adjustable weight system
- WARRANTY** Limited 3 year



ADJUSTABLE WEIGHT BOLT SYSTEM



COLORED IRISH LINEN OR NYLON WRAPS

LOGO ENGRAVED STAINLESS STEEL BUTT CAP



50-0950 | **CENTRAL PARK AFTER DARK** | Irish linen wrap | Hardwood maple forearm/sleeve | Extra 13mm shaft 53-9002 sold separately



50-0952 | **BARBADOS BLUE** | Irish linen wrap | Hardwood maple forearm/sleeve | Extra 13mm shaft 53-9002 sold separately



50-0953 | **WRAPPED IN DIAMONDS** | Nylon wrap | Hardwood maple forearm/sleeve | Extra 13mm shaft 53-9002 sold separately



50-0954 | **CASHMERE PINK** | Nylon wrap | Hardwood maple forearm/sleeve | Extra 13mm shaft 53-9002 sold separately

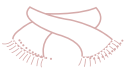



VIPER

CLUTCH

BILLIARD CUE

Shooters require a cue that performs in crucial moments. A state of the art siliconized infused dura-wick cloth wrap and Canadian maple shaft makes this cue excel in the Clutch.

- LENGTH** 58"
- JOINT SCREW** 5/16" x 18
- JOINTS** ABS
- WRAP** Siliconized infused dura-wick cloth
- BUTT CAP** ABS
- WEIGHT** 18-21oz. Adjustable weight system
- WARRANTY** Limited lifetime



ADJUSTABLE WEIGHT BOLT SYSTEM



SILICONIZED INFUSED
DURA-WICK CLOTH WRAP

FINISHED TO GIVE THE BUTT
A DISTINCT LOOK



BUILT-IN REMOVABLE SCUFFER
Replacement scuffer/bumper on page 163



PP-60 | **LIGHTS OUT** | Canadian maple forearm/sleeve

PP-61 | **CRIMSON BLAZE** | Canadian maple forearm/sleeve

PP-62 | **CERULEAN WAVE** | Canadian maple forearm/sleeve

PP-63 | **MAGENTA DUSK** | Canadian maple forearm/sleeve

PP-64 | **VIOLET CHARGE** | Canadian maple forearm/sleeve

VIPER

REVOLUTION SURE GRIP PRO

BILLIARD CUE

The Viper® Revolution Sure Grip Pro cues feature the latest performance grip technology along with Canadian maple shafts and 13mm leather tips. The rubberflex spiral grip offers a tension free stroke and is comfortable and responsive. These eye catching cues feature a metallic flaked finish and 9 coats of varnish to prevent warpage.

- LENGTH** 58"
- JOINT SCREW** 5/16" x 18
- JOINTS** ABS
- WRAP** Spiral rubberflex grip
- BUTT CAP** ABS
- WEIGHT** 18-21oz. Adjustable weight system
- WARRANTY** Limited 1 year



ADJUSTABLE WEIGHT BOLT SYSTEM



SPIRAL RUBBERFLEX GRIP

BRIGHT COLORED CHIP RESISTANT VARNISH, LIGHT METALLIC FLAKED TOP COAT

ABS BUTT CAP



50-0701 | **RED** | Maple forearm/sleeve | Extra 13mm shaft 53-9013 sold separately



50-0702 | **PURPLE** | Maple forearm/sleeve | Extra 13mm shaft 53-9013 sold separately



50-0703 | **BLACK** | Maple forearm/sleeve | Extra 13mm shaft 53-9013 sold separately



50-0704 | **BLUE** | Maple forearm/sleeve | Extra 13mm shaft 53-9013 sold separately



UNDERGROUND

BILLIARD CUE

Play bold and make a statement with the Underground billiard cue sticks from Viper®. Fashioned from Canadian maple hardwood to withstand years of use, the Underground billiard cues stand out from the rest with original artwork and graphics. These cue sticks feature all the performance-enhancing qualities you've come to expect from exceptional cues.

- LENGTH** 58"
- JOINT SCREW** 5/16" x 18
- JOINTS** ABS or stainless steel
- WRAP** Bonded leatherette, nylon, or graphic
- BUTT CAP** ABS
- WEIGHT** 18-21oz. Adjustable weight system
- WARRANTY** Limited 1 year



ADJUSTABLE WEIGHT BOLT SYSTEM



BONDED LEATHERETTE,
NYLON, GRAPHIC WRAPS

ORIGINAL ARTWORK CREATED
BY MILWAUKEE ARTISTS

ABS BUTT CAP



50-0650 | THE RAVEN
Bonded leatherette wrap
Maple forearm/sleeve
Stainless steel rings
Extra 13mm shaft 53-9015
Sold separately



50-0651 | POOL BITCH
Bonded leatherette wrap
Maple forearm/sleeve
Stainless steel rings
Extra 13mm shaft 53-9015
Sold separately

VIPER UNDERGROUND

JUNIOR CUE AVAILABLE
Page 156



50-0652 | FATAL SHOT
Nylon wrap
Maple forearm/sleeve
Stainless steel rings
Extra 13mm shaft 53-9014
Sold separately



50-0653 | ROCK & ROLL
Nylon wrap
Maple forearm/sleeve
Stainless steel rings
Extra 13mm shaft 53-9014
Sold separately

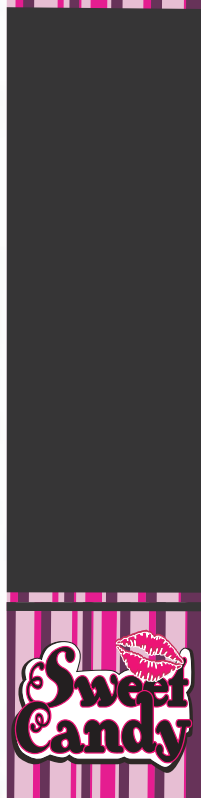

50-0654 | SWEET CANDY
Bonded leatherette wrap
Maple forearm/sleeve
Stainless steel rings
Extra 13mm shaft 53-9015
Sold separately



50-0665 | SINISTER
Bonded leatherette wrap
Maple forearm/sleeve
Stainless steel rings
Extra 13mm shaft 53-9015
Sold separately

NEW PRODUCT

JUNIOR CUE
AVAILABLE
Page 156

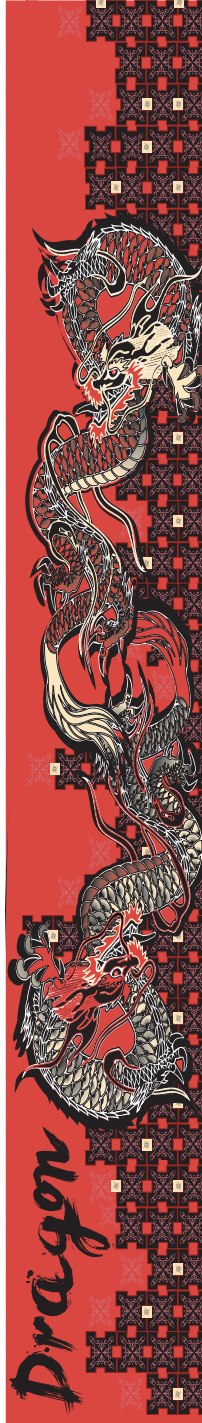

50-0659 | **DRAGON**
Maple forearm/sleeve
Stainless steel rings
Extra 13mm shaft 53-9015
Sold separately



50-0658 | **CELTIC BLOOD**
Maple forearm/sleeve
Stainless steel rings
Extra 13mm shaft 53-9014
Sold separately



50-0660 | **MUERTOS**
Maple forearm/sleeve
Stainless steel rings
Extra 13mm shaft 53-9014
Sold separately

VIPER

DIAMOND

BILLIARD CUE

Enhance your game and show off simple style with the Diamond Billiard Cue Stick from Viper®. Fashioned from Canadian maple hardwood to withstand years of use the Diamond billiard cues stand out from the rest with a classic yet polished design. A Le Pro leather tip ensures a solid grip on the ball, reducing miscues a Pro Taper gives a consistent and comfortable feel across your stroke while a bonded leatherette wrap reduces vibration and provides a great look for the budget conscious. The shaft and butt combine with resilient Implex joints providing internal strength and consistent feedback.

- LENGTH** 58"
- JOINT SCREW** 5/16" x 18
- JOINTS** Implex joint
- WRAP** Bonded leatherette
- BUTT CAP** ABS printed
- WEIGHT** 18-21oz. Adjustable weight system
- WARRANTY** Limited 1 year



ADJUSTABLE WEIGHT BOLT SYSTEM



BONDED LEATHERETTE WRAPS



ABS BUTT CAP



50-0910 | **BROWN FINISH** | Canadian maple forearm/sleeve



50-0911 | **BLUE FINISH** | Canadian Maple forearm/sleeve



50-0912 | **BURGUNDY FINISH** | Canadian maple forearm/sleeve



50-0913 | **BLACK FINISH** | Canadian maple forearm/sleeve

VIPER

GRAPHSTRIKE™

BILLIARD CUE

Rack 'em up and break into the game of billiards with Viper® Graphstrike cues. Their high strength fiberglass construction eliminates water absorption and prevents warpage. Graphstrike billiard cues are perfect for players looking to get the most bang for their buck. These cue sticks feature high-tech performance-enhancing qualities a pro would expect from exceptional cues in an excellent value package. A leather tip ensures a solid grip on the ball reducing miscues. A Pro Taper gives a steady and comfortable feel across your stroke. The shaft and butt combine with lightweight, durable aluminum joints to give reliable feedback on every shot.

- JOINT SCREW** 5/16" x 18
- JOINTS** Aluminum
- WRAP** Veltex
- WEIGHT** 19oz.
- WARRANTY** Limited 90 day



VELTEX WRAPS

FIBERGLASS CONSTRUCTION

ABS BUTT CAP



50-8115 | **BLACK** | Aluminum joint | Veltex wrap



50-8116 | **BLUE** | Aluminum joint | Veltex wrap



50-8117 | **MAROON** | Aluminum joint | Veltex wrap

VIPER[®] SIGNATURE

BILLIARD CUE

Fashioned from Canadian maple hardwood to withstand years of use, the Signature Realtree[®] billiard cues stand out from the rest with officially licensed Realtree[®] camouflage graphics. A Le Pro leather 13mm tip ensures a solid grip on the ball, reducing miscues, while a gradual taper gives a natural and comfortable feel across your stroke. The shaft and butt combine with durable ABS joints, which are secured with brass pins to give consistent feedback on every shot.

- LENGTH** 57"
- JOINT SCREW** 5/16" x 18
- JOINTS** ABS
- WRAP** Nylon
- BUTT CAP** ABS
- WEIGHT** 19 or 20oz.
- WARRANTY** Limited 1 year



REALTREE HARDWOODS HD © 2001 of Jordan Outdoor Enterprises, Ltd., All rights reserved



ADVANTAGE MAX-4 HD © 2002 of Jordan Outdoor Enterprises, Ltd., All rights reserved



NYLON WRAPS

REALTREE GRAPHICS

ABS BUTT CAP



50-9000 | REALTREE HARDWOODS[®] CAMOUFLAGE | ABS joint | Nylon wrap | 57 in. | 19 or 20 oz. | Hardwood maple forearm/sleeve



50-9003 | REALTREE MAX-4[®] CAMOUFLAGE | ABS joint | Nylon wrap | 57 in. | 19 or 20 oz. | Hardwood maple forearm/sleeve

VIPER ELITE

BILLIARD CUE

Each Elite cue is fashioned from maple hardwood to withstand years of use. For players looking to take the first step into competitive play, these cues will make a great choice for the budget conscious. These cue sticks feature all the performance-enhancing qualities you've come to expect from exceptional cues. A Le Pro 13mm leather tip ensures a solid grip on the ball, while a Pro Taper gives an even and comfortable feel across your stroke. Finally, they are finished off with a comfortable Irish linen wrap.

- LENGTH** 58"
- JOINT SCREW** 5/16" x 18
- JOINTS** ABS
- WRAP** Irish linen or finished
- BUTT CAP** ABS
- WEIGHT** 18-21oz. Adjustable weight system - PP 13-17
- WARRANTY** Limited 1 year



ADJUSTABLE WEIGHT BOLT SYSTEM



2 COLOR IRISH LINEN WRAP OR UNWRAPPED

FINISH FINISHED AND PAINTED

ABS BUTT CAP

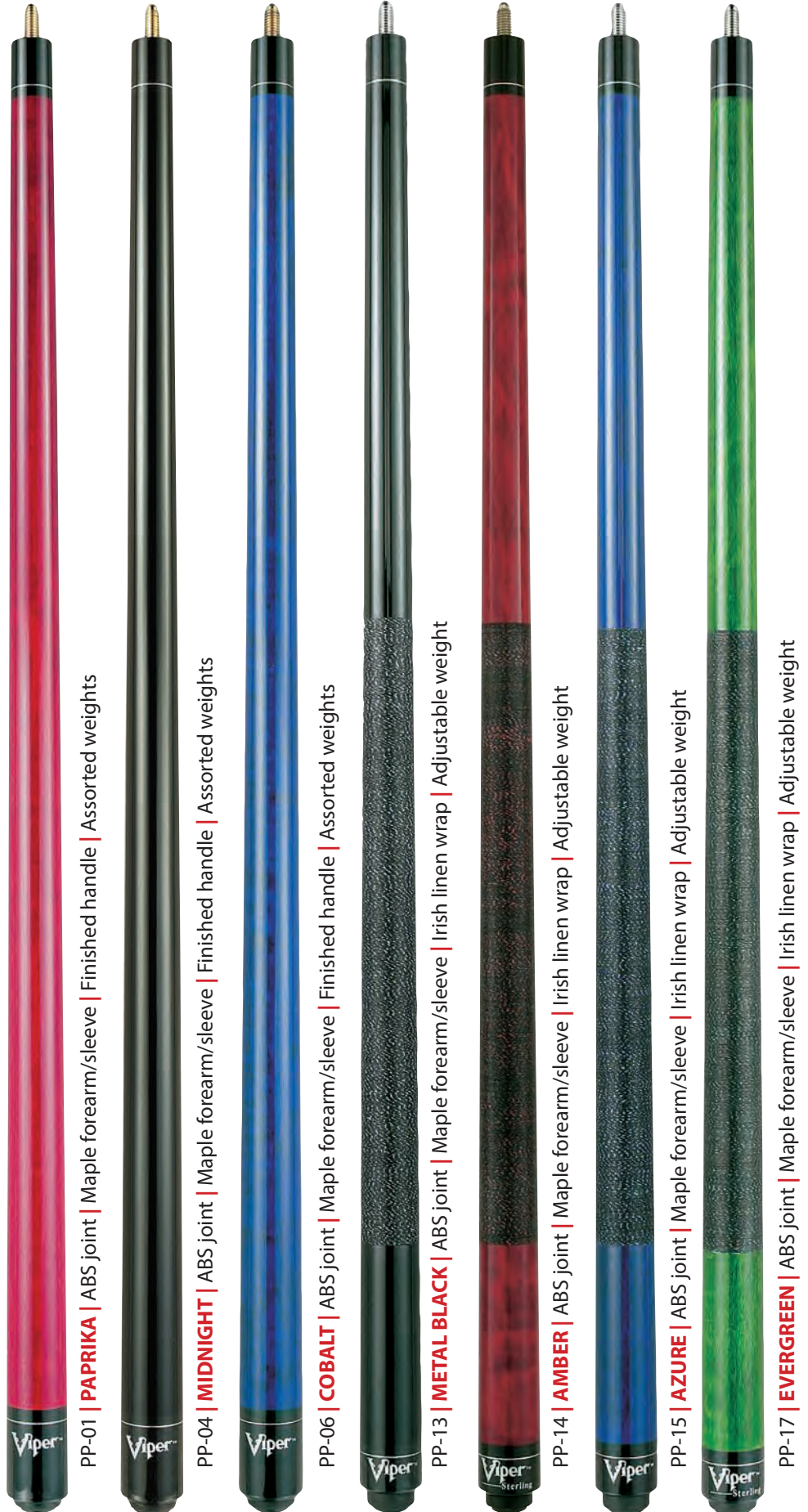

PP-01 | PAPIRIKA | ABS joint | Maple forearm/sleeve | Finished handle | Assorted weights

PP-04 | MIDNIGHT | ABS joint | Maple forearm/sleeve | Finished handle | Assorted weights

PP-06 | COBALT | ABS joint | Maple forearm/sleeve | Finished handle | Assorted weights

PP-13 | METAL BLACK | ABS joint | Maple forearm/sleeve | Irish linen wrap | Adjustable weight

PP-14 | AMBER | ABS joint | Maple forearm/sleeve | Irish linen wrap | Adjustable weight

PP-15 | AZURE | ABS joint | Maple forearm/sleeve | Irish linen wrap | Adjustable weight

PP-17 | EVERGREEN | ABS joint | Maple forearm/sleeve | Irish linen wrap | Adjustable weight

VIPER JUNIOR



REALTREE HARDWOODS HD® 2001 of Jordan Outdoor Enterprises, Ltd. All rights reserved

BILLIARD CUE

For pro level quality in a small package look no further than the Viper® Junior billiard cue sticks. Fashioned from maple hardwood to withstand years of use, the smaller size of the Viper® Junior Billiard Cue makes it a great starting point for younger players or those without much space to maneuver. These cue sticks feature all the performance-enhancing qualities you've come to expect from exceptional cues. A Le Pro leather tip ensures a solid grip on the ball, reducing miscues. A gradual taper gives a natural and comfortable feel across your stroke. The shaft and butt combine with durable ABS joints to give consistent feedback on every shot.

- LENGTH** 48"
- JOINT SCREW** 5/16" x 18
- JOINTS** ABS
- WRAP** Nylon or graphic
- BUTT CAP** ABS
- WEIGHT** Various weights
- WARRANTY** Limited 1 year

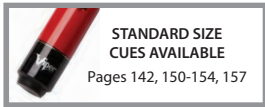

NYLON OR GRAPHIC WRAPS

ORIGINAL ARTWORK CREATED BY MILWAUKEE ARTISTS

ABS BUTT CAP



50-0400 | REALTREE HARDWOODS HD® JR. | ABS joint | Nylon wrap | 48 in. | Hardwood maple forearm/sleeve



50-0401 | PINK LADY JR. | ABS joint | Nylon wrap | 48 in. | Hardwood maple forearm/sleeve



50-0402 | JR. SPIDER | ABS joint | Nylon wrap | 48 in. | Hardwood maple forearm/sleeve



50-0404 | ROCK & ROLL | Nylon wrap | 48 in. | Maple forearm/sleeve | Stainless steel rings



50-0406 | PINK BONES | 48 in. | Maple forearm/sleeve | Stainless steel rings



50-0407 | DRAGON | 48 in. | Maple forearm/sleeve | Stainless steel rings

JUNIOR CUE
AVAILABLE
Page 156



ADDITIONAL CUES

BILLIARD CUE

When no other cue can satisfy the billiard masters' need to succeed, these cues stand out. Remember part of our Pink Lady cue profits are donated to the Wisconsin Breast Cancer Showhouse.

- LENGTH** 57" or 58"
- JOINT SCREW** 5/16" x 18
- JOINTS** ABS
- WRAP** Irish linen or nylon, none for Sneaky Pete
- BUTT CAP** ABS
- WEIGHT** Adjustable weight system on select cues
- WARRANTY** Limited 1 year



ADJUSTABLE WEIGHT BOLT SYSTEM



BUILT-IN REMOVABLE SCUFFER ON SNEAKY PETE AND JUMP BREAK CUES
Replacement scuffer/bumper on page 163



JUMP BREAK CUES DISASSEMBLE INTO THREE PIECES.



50-0225 | **PINK LADY** | ABS joint | Irish linen wrap | Adjustable 18-21 oz. | 58" | Hardwood maple forearm/sleeve | Extra 13mm shaft 53-9008 sold separately



50-0275 | **HOT PINK** | ABS joint | Irish linen wrap | Only 19 & 20 oz. | 57" | Maple forearm/sleeve



50-0501 | **SNEAKY PETE ZEBRAWOOD** | Wood to wood joint with brass insert | Irish linen wrap | 19-21 oz. | 58" | Extra 13mm shaft 53-9012 sold separately



50-0503 | **BLACK JUMP BREAK** | ABS joint | Nylon wrap | 18-21 oz. Adjustable weight system | 58" | Extra 13mm shaft 53-9011 sold separately

VIPER[®] COMMERCIAL

BILLIARD CUE

The perfect answer for the player who needs a cue to be used day in, day out with quality and cost in mind: the Viper[®] One-Piece Commercial Billiard Cue Stick. Fashioned from a solid piece of hardwood to withstand years of use, the commercial cue is designed with dependability in mind. These cue sticks give you the most bang for your buck and include several performance enhancing features. A leather tip ensures a solid grip on the ball, reducing miscues. An even, gradual taper gives a steady and comfortable feel across your stroke. The solid, one-piece construction gives a great feedback on every shot. When you need quality cues that will stand up to heavy use at a great price, look no further! All Commercial cues include a 90 day warranty.



DETAIL VIEW
50-0050



DETAIL VIEW
50-0051

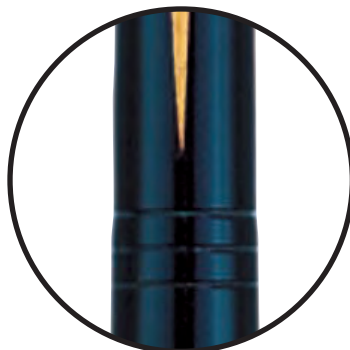

DETAIL VIEW
50-0301



50-0050 | VIPER[®] 36" HARDWOOD

Sold in
6 packs



50-0051 | VIPER[®] 36" MAPLE
50-0504 | VIPER[®] 48" MAPLE

Includes 13mm leather tip | ABS ferrule

- 50-0100-18 | 57" MAPLE | 18 oz.
- 50-0100-19 | 57" MAPLE | 19 oz.
- 50-0100-20 | 57" MAPLE | 20 oz.
- 50-0100-21 | 57" MAPLE | 21 oz.



50-0301 | VIPER[®] 48" HARDWOOD
50-0302 | VIPER[®] 52" HARDWOOD
50-0303 | VIPER[®] 57" HARDWOOD

Includes 13mm leather tip | ABS ferrule

Sold in
6 packs



CASEMASTER®

NEW PRODUCT

PARALLAX

BILLIARD CUE CASE

BLACK TRIM **51-0400-01**

BLUE TRIM **51-0400-03**

PURPLE TRIM **51-0400-06**

ORANGE TRIM **51-0400-09**

GREEN TRIM **51-0400-10**

PINK TRIM **51-0400-12**

CASE DIMENSIONS 33.63"L x 5.13"W x 2.5"H

INNER DIMENSIONS BUTT - 31"L x 1.25"W x 1"H
SHAFT - 30"L x 0.88"W x 0.63"H

FEATURES

- Holds 1 butt, 1 shaft, and 1 cue chalk
- Abrasion resistant
- Water repellant
- Padded interior
- Rubber handle
- Slim profile
- 90 day warranty

CUE AND CHALK NOT INCLUDED





CLASSIC Q-VAULT

BILLIARD CUE CASE **51-0600-01**

CASE DIMENSIONS 31.75"L x 3.75"W x 3"H

INNER DIMENSIONS BUTT - 1.34"L x 29.4"W
SHAFT - 0.9"L x 29.4"W

FEATURES

- Holds 1 butt and 1 shaft
 - Fully lined interior
 - 2 Accessory pouches
 - Black leatherette
 - 90 day warranty
- CUE STICK NOT INCLUDED



SUPREME Q-VAULT

BILLIARD CUE CASE

RED TRIM **51-0706-02**

BLUE TRIM **51-0706-03**

GREEN TRIM **51-0706-10**

PINK TRIM **51-0706-12**

CASE DIMENSIONS 32"L x 4"W x 4"H

INNER DIMENSIONS 2.2"L x 31"W

FEATURES

- Holds 1 butt and 1 shaft
 - Fully lined interior
 - Removable accessory pouch
 - Leatherette hard case
 - Adjustable shoulder strap
 - 90 day warranty
- CUE STICK NOT INCLUDED





CLASSIC Q-VAULT

BILLIARD CUE CASE **51-0601-01**

CASE DIMENSIONS 31.75"L x 4"W x 3"H

INNER DIMENSIONS BUTT - 1.34"L x 29.4"W
SHAFT - 0.9"L x 29.4"W

FEATURES

- Holds 2 butts and 2 shafts
 - Fully lined interior
 - Black textured leatherette
 - 90 day warranty
- CUE STICKS NOT INCLUDED



SUPREME Q-VAULT

BILLIARD CUE CASE

BLACK **51-0700-01**

BLUE **51-0700-03**

PINK **51-0700-12**

CASE DIMENSIONS 32"L x 4"W x 4"H

INNER DIMENSIONS 2.2"L x 31"W

FEATURES

- Holds 1 butt and 1 shaft
 - Fully lined interior
 - Removable accessory pouch
 - Leatherette hard case
 - Adjustable shoulder strap
 - 90 day warranty
- CUE STICK NOT INCLUDED





DELUXE HARD CASE

BILLIARD CUE CASE **27-0306**

CASE DIMENSIONS 32"L x 4"W x 1"H
INNER DIMENSIONS BUTT - 1.31"L x 31.3"W
 SHAFT - 1"L x 31.3"W

FEATURES

- Holds 1 butt and 1 shaft
- Fully lined interior
- 2 Accessory pouches
- Hard black leatherette
- Padded to protect cues
- 90 day warranty
- CUE STICK NOT INCLUDED



CONO CASE

BILLIARD CUE CASE **27-0106-01**

CASE DIMENSIONS 32"L x 4"W x 1"H
INNER DIMENSIONS 3.4"L x 30.7"W

FEATURES

- Holds 1 butt and 1 shaft
- Fully lined interior
- Padded to protect cues
- 90 day warranty
- CUE STICK NOT INCLUDED



REALTREE® HD CASE

BILLIARD CUE CASE **27-0815**

CASE DIMENSIONS 31.5"L x 4"W x 0.5"H
INNER DIMENSIONS 3.4"L x 30.7"W

FEATURES

- Soft Realtree® camo print case
- Holds 1 butt and 1 shaft
- Fully lined interior
- Black leatherette
- 90 day warranty
- CUE STICK NOT INCLUDED

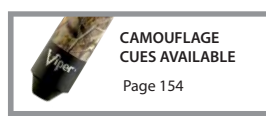

REALTREE HARDWOODS HD® 2001 of Jordan Outdoor Enterprises, Ltd., All rights reserved



BILLIARD ACCESSORIES



VIPER
MASTER POOL BALL SET 53-0794
 Complete set of 2 1/4" diameter billiard balls



VIPER
TABLE COVER 27-0817
 One size fits most, up to 9' tables
 3 pack



VIPER
8 CUE WOODEN WALL RACK
 52-0103 | Mahogany
 CUES NOT INCLUDED



VIPER
6 CUE WOODEN WALL RACK
 27-0099 | Oak
 CUES NOT INCLUDED



CUE REPLACEMENT BUMPER
 53-0404



VIPER
CUE JOINT AND TIP PROTECTOR
 27-0857 | Silicone
 5 Pack
 CUES NOT INCLUDED



CUE JOINT PROTECTORS 5/16" - 18
 53-0856-01
 5 Pack



DELUXE CONE CHALK HOLDER
 53-0713 Mahogany
 CHALK NOT INCLUDED



CONE CHALK
 53-0705
 6 Pack



SILVER CUP® TALC POWDER
 53-0715 | 8 oz. can
 12 pack



CONE CHALK HOLDER
 27-0713
 6 Pack



SILVER CUP®
BLACK CHALK
 53-0707-01
 12 pack



SILVER CUP®
BLUE CHALK
 53-0707-03
 12 pack



SILVER CUP®
GREEN CHALK
 53-0707-08
 12 pack



SILVER CUP®
BURGUNDY CHALK
 53-0707-18
 12 pack



SILVER CUP®
TAN CHALK
 53-0707-22
 12 pack

PROFESSIONAL WEIGHT BOLT SYSTEM

For Viper® Adjustable Weight Bolt Cues

- 7oz. | 53-1007
- 6oz. | 53-1006
- 5oz. | 53-1005
- 4oz. | 53-1004
- 3oz. | 53-1003
- 2oz. | 53-1002
- 1oz. | 53-1001
- 0.5oz. | 53-1000

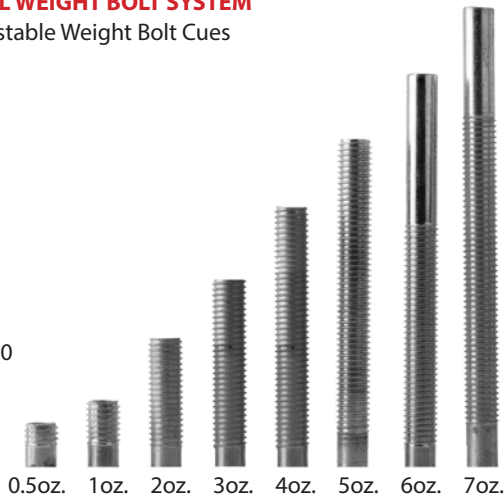

**WEIGHT BOLT
IN USE**



**CUE WRENCH
53-1050**



**SCUFFER RUBBER BUMPER
53-0864**

VIPER
**OAK WOODEN
CUE RACK**

CUE RACK **52-0121**

FEATURES

- Holds 10 cues
 - Holds 1 full set of balls
 - Holds 1 cone chalk
 - 4 Drink holders
- CUES, BALLS, & TRIANGLE
NOT INCLUDED



VIPER
**OAK & MAHOGANY
WOODEN CUE RACK**

OAK CUE RACK **52-0115**

MAHOGANY CUE RACK **52-0116**

FEATURES

- Holds 8 cues
 - Wall mounted
 - Includes mounting hardware
- CUES NOT INCLUDED



VIPER
WOOD TRIANGLE
27-0100
6 pack



VIPER
WOOD 9 BALL RACK
27-0104
6 Pack

HOME CASINO

TABLES

Those looking to recreate the casino atmosphere at home should start off with a table that suits their lifestyle. We have tables for poker or blackjack players. All tables feature high quality, casino grade cloth table tops and are convenient for storage and moving purposes.

CHIP SETS

No home casino is complete without the ultimate poker chip set. Whether you play blackjack or poker, we have the perfect poker chip set for you. All poker chip sets feature a carrying case for travel, storage—and most importantly—protection.

ACCESSORIES

We offer an array of accessories that make the poker playing experience more fun and enjoyable. Products such as a card shuffler and card shoe to make dealing easier, a poker chip tray for organization and spare poker chips in case you lose some. A poker player can never be unprepared!

TAKE THE CASINO HOME WITH YOU

Playing iconic card games at the casino is a great pastime that many wish they could enjoy more often. With our Home Casino products, we make it easy for you to recreate that same casino experience that you know and love, in your very own home. From tables and poker chip sets to dealing accessories, we have everything to get you started. Now you can set your own stakes when playing against friends and family.





TEXAS HOLD'EM POKER TABLE



Step 1



Step 2



Step 3

POKER TABLE 64-2039

Set this poker table up anywhere for a casino atmosphere.

DIMENSIONS	83.5" L x 41.75" W x 29.5" H
FOLDED DIMENSIONS	41.75" L x 41.75" W x 4.5" H
CARTON DIMENSIONS	44" L x 44" W x 6" H
SHIPPING CARTON DIMENSIONS	45" L x 45" W x 10" H
SHIPPING CARTON WEIGHT	92 lbs. with pallet
GROSS WEIGHT	59 lbs.
NET WEIGHT	47 lbs.
WARRANTY	Limited 90 day

FEATURES

- Casino grade cloth
- Metal legs with reinforced platform for strength and lightweight convenience
- Elegant water-resistant cushioned rail with 10 drink holders
- Revolutionary table lock suspension for the most stable playing table on the market



ACCESSORIES NOT INCLUDED
(Found on pages 168 - 169)

US Patent #7156396,
7575240, and 7387299





TEXAS HOLD'EM POKER TOP

POKER TOP **64-2003**

This table turns most flat surfaces into a poker table in an instant.

- DIMENSIONS** 83.5"L x 41.5"W x 2"H
- FOLDED DIMENSIONS** 41.5"L x 41.5"W x 4.5"H
- GROSS WEIGHT** 34 lbs.
- NET WEIGHT** 27 lbs.
- WARRANTY** Limited 90 day



FEATURES

- Extra thick cushioned rail with 10 built-in drink holders
- Trifold table easily unfolds and lies flat on any surface
- Padded back prevents damage to furniture
- Durable strap with heavy duty snaps, secures the top for easy transportation and dust free storage
- Green cloth playing surface

ACCESSORIES NOT INCLUDED
(Found on pages 168 - 169)



POKER/BLACKJACK TABLE TOP

POKER TOP **64-2004**

Transforms any standard table to a great game playing surface.

- DIMENSIONS** 47.5"L x 47.5"W x .75"H
- FOLDED DIMENSIONS** 47.5 "L x 23.75"W x 1.5"H
- GROSS WEIGHT** 15 lbs.
- NET WEIGHT** 14 lbs.
- WARRANTY** Limited 90 day



FEATURES

- Padded base protects table surface
- Folds in half for easy storage
- Convenient carrying case for transportation and dust free storage
- Seats 8 with individual built-in poker chip and drink holders
- Constructed of solid wood and EVA materials for a lighter but extremely strong table

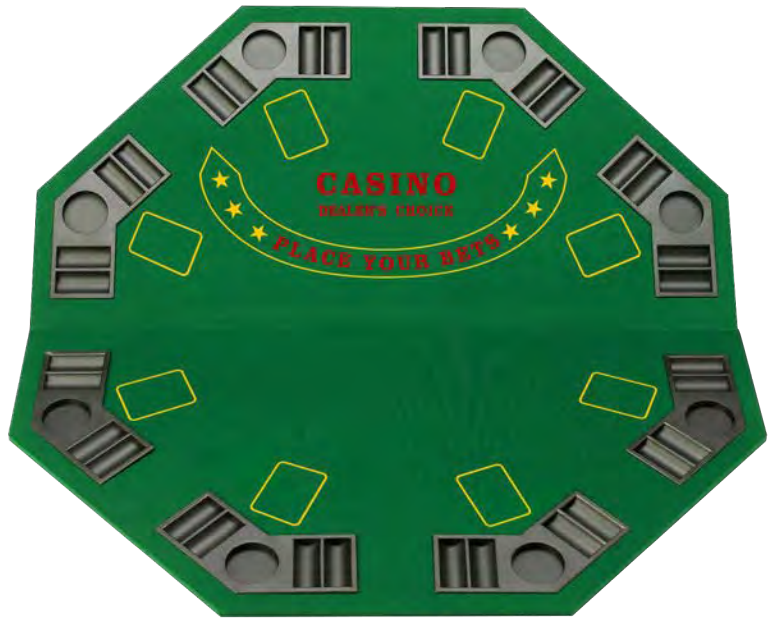



TEXAS HOLD'EM POKER CHIP SET

SILVER POKER SET 55-0605

CHIPS 500 Count 11.5 gm Claytec

FEATURES

- Silver aluminum storage case with carrying handles makes traveling poker a breeze
- Weighted poker chips with a casino sound
- 2 Decks of cards
- 1 Set of game buttons
- Limited 90 day warranty



CHIPS

- RED** 150 chips, 11.5 gm Claytec
- WHITE** 150 chips, 11.5 gm Claytec
- BLUE** 100 chips, 11.5 gm Claytec
- BLACK** 50 chips, 11.5 gm Claytec
- GREEN** 50 chips, 11.5 gm Claytec



BLING POKER CHIP SET

BLACK POKER SET 55-0655

CHIPS 500 Count 13.5 gm Claytec

FEATURES

- Black aluminum storage case with carrying handles makes traveling poker a breeze
- Weighted poker chips with a casino sound
- 2 Decks of cards
- 1 Set of game buttons
- 5 Weighted poker dice
- Limited 90 day warranty



CHIPS

- RED** 150 chips, 13.5 gm Claytec
- WHITE** 150 chips, 13.5 gm Claytec
- BLUE** 100 chips, 13.5 gm Claytec
- BLACK** 50 chips, 13.5 gm Claytec
- GREEN** 50 chips, 13.5 gm Claytec





HOME CASINO ACCESSORIES



POKER CHIP TRAY **55-0607**

- Two 100 count trays in every pack
- Space-saving and easy to carry stackable trays
- 8.5"L x 3.13"W x 3"H

CHIPS NOT INCLUDED



CARD SHOE **55-0114**

- Clear acrylic holder
- Holds up to 4 decks of cards
- Weighted pusher with roller
- 10.5"L x 4"W x 3.63"H



DICE CUP **55-0100**

- Handsome leatherette covering lends a high quality look
- Green cloth interior ensures dice roll evenly
- A reinforced bottom allows the cup to withstand the toughest players
- Included are five dice, you'll be ready to play out of the box
- 3.54"L x 3.14"W x 3.14"H



TEXAS HOLD'EM POKER CHIP CASE **55-0604**

- Ten fifty count chip slots with dice tray, and dual card holder
- Silver aluminum case with carrying handle and reinforced corners for games on the go
- Metal security clasps
- Cushioned interior
- 22"L x 8.26"W x 2.44"H



MAINSTREET CLASSICS



CLASSIC 23" BACKGAMMON SET

23" GAME SET **55-0919**

OPEN DIMENSIONS 23"L x 18"W x 1"H

CLOSED DIMENSIONS 11.5"L x 18"W x 2"H

PACKAGE 18.38"L x 11.75"W x 2.25"H

WARRANTY Limited 90 day

FEATURES

- Leatherette case with metal clasp
- Velvet and leatherette interior
- Decorative white running stitch
- Stitched leatherette backgammon triangles
- Backgammon playing pieces (15ea. 1 1/16" L x 7/16" W)
- Two leatherette dice cups with decorative running stitch (3" L x 2 1/16" W x 1 1/2" H)
- One backgammon doubling cube (5/8" L x 5/8" W)
- Two pairs of dice (7/16" L x 7/16" W)
- Playing instructions



BROADWAY COMBO SET

5-in-1 GAME SET **55-0207**

DIMENSIONS 13.13"L x 13.38"W x 2.5"H

PACKAGE 14"L x 13.5"W x 3"H

WARRANTY Limited 90 day

FEATURES

- Leatherette case with velvet interior
- Decorative white running stitch
- Stitched leatherette backgammon triangles
- Natural and finished wooden chess pieces (king 3")
- Backgammon/checkers pieces (15ea. 25/32" x 3/16")
- One backgammon doubling cube (5/8" L x 5/8" W)
- Two pairs of dice (7/16" L x 7/16" W)
- 60 Chinese checker marbles (23/32") (6 colors, 10 per color)
- Two storage drawers
- Four cloth drawstring storage bags
- Playing instructions

GAMES

- Chess
- Checkers
- Chinese Checkers
- Backgammon
- Dice game





CLASSIC 20" BACKGAMMON SET

20" GAME SET **55-0619**

OPEN DIMENSIONS 20"L x 15"W x 1"H

CLOSED DIMENSIONS 10"L x 15"W x 2"H

PACKAGE 15.25"L x 10.38"W x 2.25"H

WARRANTY Limited 90 day

FEATURES

- Leatherette case with metal clasp
- Velvet and leatherette interior
- Decorative white running stitch
- Stitched leatherette backgammon triangles
- Backgammon playing pieces (15ea. 1 1/16" L x 7/16" W)
- Two leatherette dice cups with decorative running stitch (3" L x 2 1/16" W x 1 1/2" H)
- One backgammon doubling cube (5/8" L x 5/8" W)
- Two pairs of dice (7/16" L x 7/16" W)
- Playing instructions

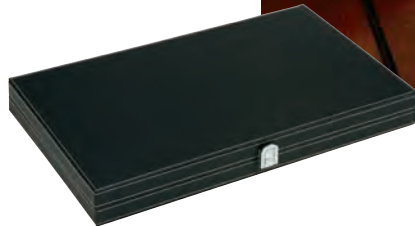

PENNSYLVANIA AVE BACKGAMMON SET

23" GAME SET **55-0709**

OPEN DIMENSIONS 23"L x 18"W x 1"H

CLOSED DIMENSIONS 11.5"L x 18"W x 2"H

PACKAGE 18.38"L x 11.75"W x 2.25"H

WARRANTY Limited 90 day

FEATURES

- Leatherette case with metal clasps
- Velvet and leatherette interior
- Attractive pin striping
- Stitched leatherette backgammon triangles
- Backgammon playing pieces (15ea. 1 1/16" L x 7/16" W)
- Two leatherette dice cups with decorative running stitch (3" L x 2 1/16" W x 1 1/2" H)
- One backgammon doubling cube (5/8" L x 5/8" W)
- Two pairs of dice (7/16" L x 7/16" W)
- Playing instructions





WOODEN "29" CRIBBAGE BOARD

GAME BOARD **55-0104**

DIMENSIONS 9.5"L x 7"W x 0.63"H

WARRANTY Limited 90 day

FEATURES

- Convenient slotted storage channel on the back of the board
- Board decorations feature the traditional three player game track in classic red, green and blue colors
- Made from solid wood for long lasting durability and natural beauty with a clear finish
- Complete with nine playing pieces
- Best possible cribbage hand and double "5" board designs



BUILT-IN PEG STORAGE



BARONY WOODEN CRIBBAGE BOARD

GAME BOARD **55-0106**

DIMENSIONS 14.75"L x 3.25"W x 0.63"H

WARRANTY Limited 90 day

FEATURES

- Made from solid wood for long lasting durability and natural beauty with a clear finish
- Board decorations feature the traditional three player game track in classic red, green and blue colors
- Complete with nine playing pieces
- Convenient slotted storage channel on the back of the board





Mainstreet Classics



DUTCHMAN GAME SET

15.75" 3-in-1 GAME SET **55-0202**

OPEN DIMENSIONS 15.5"L x 15.75"W x 1"H

CLOSED DIMENSIONS 7.75"L x 15.75"W x 2"H

WARRANTY Limited 90 day

FEATURES

- Playfield for chess, checkers, and backgammon
- Folds in half for easy storage
- Convenient carrying handle
- Two wooden cups and 5 dice
- Chess pieces, king 3 1/8"H
- Backgammon/Checker pieces
- Playing instructions



MICRO BAG TOSS

MINI GAME SET **55-0500**

DIMENSIONS 16"L x 10.5"W x 1.25"H

NET WEIGHT 5.5 lbs

GROSS WEIGHT 6 lbs

WARRANTY Limited 90 day

FEATURES

- Includes 8 durable bean bags
- Retractable legs
- Carrying handles
- Hook and loop seal on panel



4 RED BAGS



4 GRAY BAGS





SINISTER™ TABLE TOP BILLIARDS

MINI GAME SET	55-0501
DIMENSIONS	20.13"L x 12.25"W x 3.5"H
PLAYFIELD DIMENSIONS	19"L x 11.5"W
NET WEIGHT	6 lbs
GROSS WEIGHT	6.5 lbs
WARRANTY	Limited 90 day

FEATURES

- Playfield surface features high quality evergreen cloth
- Designed to look and feel like a tournament table
- Includes two cues, one set of billiard balls, triangle, table brush, chalk
- Side ball return



SINISTER™ TABLE TOP HOCKEY

MINI GAME SET	55-0503
DIMENSIONS	22"L x 12.5"W x 4"H
PLAYFIELD DIMENSIONS	19.5"L x 11"W
NET WEIGHT	4.75 lbs
GROSS WEIGHT	5.5 lbs
WARRANTY	Limited 90 day

FEATURES

- Compact construction for maximum portability
 - Full table hockey experience with powerful 12V Motor, powered by 8 AA batteries
 - Includes 2 table top pushers and 2 table top pucks pushers sized for the mini table
 - Convenient slide scorer
- BATTERIES NOT INCLUDED





Mainstreet Classics



SINISTER™ TABLE TOP FOOSBALL

MINI GAME SET **55-0502**

- DIMENSIONS** 20"L x 12.5"W x 4"H
- PLAYFIELD DIMENSIONS** 15.75"L x 11.63"W
- NET WEIGHT** 5 lbs
- GROSS WEIGHT** 6 lbs
- WARRANTY** Limited 90 day

FEATURES

- Compact construction allows for maximum portability
- Arcade style automatic ball return
- Includes 2 soccer style foosballs sized for the mini table
- 4 Metal rods for the foosmen
- Comfortable rubber grip handles
- Convenient slide scorer



36" FOOSBALL

TABLE TOP FOOSBALL **55-0511**

- DIMENSIONS** 36.75"L x 20"W x 11.75"H
- PLAYFIELD DIMENSIONS** 31.25"L x 19"W
- PACKAGE** 38.25"L x 22"W x 4.75"H
- NET WEIGHT** 24.25 lbs
- GROSS WEIGHT** 28.75 lbs
- WARRANTY** Limited 90 day

FEATURES

- 1/8" Thick playfield with laminated grass texture graphic
- 1/2" Player rods with blue and red jersey playing men
- Manual scorers for fast and accurate scoring
- Includes two soccer style foosballs





42" TABLE HOCKEY

TABLE TOP AIR HOCKEY **55-0512**

DIMENSIONS	42"L x 24"W x 12"H
PLAYFIELD DIMENSIONS	37.75"L x 19.75"W
PACKAGE	45.75"L x 27.75"W x 5.5"H
NET WEIGHT	29.75 lbs
GROSS WEIGHT	35.25 lbs
WARRANTY	Limited 90 day

FEATURES

- 1/8" Thick playfield featuring original graphics
- 110V motor with adapter provides steady air flow for more realistic table hockey action
- Scorers for fast and accurate scoring
- Includes two pushers and two pucks
- Adapter: 12V DC 500mA, negative to positive



35" TABLE HOCKEY

TABLE TOP AIR HOCKEY **55-0510**

DIMENSIONS	35"L x 20"W x 8.25"H
PLAYFIELD DIMENSIONS	34.5"L x 19"W
PACKAGE	40.5"L x 22"W x 4"H
NET WEIGHT	11 lbs
GROSS WEIGHT	14.5 lbs
WARRANTY	Limited 90 day

FEATURES

- 1/8" Thick playfield featuring original graphics
- Compact size enables easy storage and portability for condensed fun anywhere with a table or flat surface
- 110V motor with adapter provides steady air flow for more realistic table hockey action
- Includes two pucks, two pushers, and two sliding scorers for score-keeping
- Adapter: 12V DC 500mA, negative to positive



TABLE GAMES

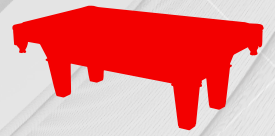

GLD is proud to lead the industry with an innovative line of game tables. Perfect for serious and casual players alike, our selection of table games is perfect for those looking to upgrade their game room.



BILLIARDS

This popular parlor game requires skill and precision. Don't get hustled by inferior tables. GLD's billiard tables feature the highest quality without breaking the bank.



MULTI-GAMES

Perfect for those looking for the action of all the popular table games in one convenient table game. GLD's own Pockey® tables feature a patented latch system for maximum sweetness.



TABLE HOCKEY

Relive the action of the arcade with this classic table game. Our dynamic table hockey tables are loaded with options to keep the pucks flying and the action flowing.



FOOSBALL

Based on the popular arena event, Foosball is a game of high speeds, lightning fast strikes, and stunning scores!

Net Weight* - Indicates the assembled weight of the table
 Gross Weight** - Indicates the weight of the table in its packaging
 Shipping Weight*** - Indicates the weight of a single table in its packaging plus the pallet and pallet topper where applicable



RENO II

7.5 ft. BILLIARD TABLE 64-0126

Bring luxury and class into your home with the Fat Cat® Reno II 7.5 foot billiard game table. This beautiful table has six-inch rails with white diamond inlays, burgundy wool cloth and beveled legs with maple wood veneers and a cherry finish. These aspects combine to form a beautifully-made table. The table also features a one-inch Accuslate™ playing surface and K66 rubber bumpers, allowing for better play. The Accuslate playing surface comes with a seven-year warranty.

DIMENSIONS	89.5"L x 50.5"W x 31"H
PLAYFIELD DIMENSIONS	78"L x 39"W
SHIPPING CARTON	92"L x 56"W x 12"H
NET WEIGHT*	313 lbs
GROSS WEIGHT**	335 lbs
SHIPPING WEIGHT***	445 lbs
WARRANTY	90 day
WARRANTY ON ACCUSLATE™ PLAY SURFACE	7 Year

FEATURES

- Pearlized diamond inlays
- Fringed drop pockets with iron brackets
- Burgundy wool blend cloth
- 6" Solid wood rails, K66 rubber bumper
- Beveled legs; 75" maple wood veneers with a cherry finish
- 1" Accuslate™ play surface for superior warp resistance
- Seven year warranty on Accuslate play surface

ACCESSORIES

- Two Pieces of performance chalk
- Two Resin triangle
- Two 57" Two-piece hardwood cues
- One Rail brush
- One Set of 2 ¼" competition billiard balls

SOME ASSEMBLY REQUIRED



FRINGED DROP POCKETS

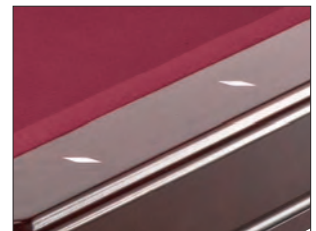

PEARLIZED DIAMOND INLAYS



FRISCO II

7.5 ft. BILLIARD TABLE **64-0127**

Your game room will become the hottest place to be with the Fat Cat® Frisco II billiard table! This 7.5 foot table is sure to bring hours of fun to your whole family, and complete the look of your game room with its classic style. The Frisco II features an Accuslate™ playing surface, just beneath the cloth cover. Accuslate gives you a smooth playing surface for years, as it is resistant to warping, and costs just a fraction of what it would take to install a slate table top.

DIMENSIONS	89.5"L x 50.5"W x 31"H
PLAYFIELD DIMENSIONS	78"L x 39"W
SHIPPING CARTON	92"L x 56"W x 12"H
NET WEIGHT*	313 lbs
GROSS WEIGHT**	335 lbs
SHIPPING WEIGHT***	429 lbs
WARRANTY	90 day
WARRANTY ON ACCUSLATE™ PLAY SURFACE	7 Year

FEATURES

- Pearlized diamond inlays
- French-style fringed drop pockets with iron brackets
- Hidden leg levelers
- Brown wool blend cloth
- 6" Solid wood rails, K66 rubber bumper
- Beveled legs; ¾" wood veneers with a maple finish
- 1" Accuslate™ play surface for superior warp resistance
- Seven year warranty on Accuslate play surface

ACCESSORIES

- Two pieces of performance chalk
- One resin triangle
- Two 57" Two-piece hardwood cues
- One set of 2 ¼" competition billiard balls

SOME ASSEMBLY REQUIRED



FRENCH-STYLE DROP POCKETS



PEARLIZED DIAMOND INLAYS



TUCSON MMXI

7 ft. BILLIARD TABLE **64-0146**

For hours of family fun and a modern centerpiece to the game room we present the Fat Cat® Tucson MMXI billiard table! This 7' table is sure to be the subject of many game nights to come, and will look good while doing it. The Tucson MMXI look begins with the finish. A deep black finish give this pool table its signature arcade look. This finish and construction is designed to invoke feelings of modern pool playing centers. The pockets are built into the rails, hiding the ball return system in a sleek package. Completing the contemporary design are the curved pedestal style legs.

DIMENSIONS	84"L x 46.5"W x 31"H
PLAYFIELD DIMENSIONS	75"L x 37.5"W
SHIPPING CARTON	92"L x 56"W x 12"H
NET WEIGHT*	192 lbs
GROSS WEIGHT**	225 lbs
SHIPPING WEIGHT***	345 lbs
WARRANTY	90 day

FEATURES

- Electric blue low-friction cloth
- Modern side ball return system
- Circular pearlized sites
- Rubber bumpers designed for minimal energy absorption
- Arcade-style legs with adjustable leg levelers
- ¾" Thick moisture-resistant play surface



ARCADE STYLE LEGS

ACCESSORIES

- One set of 2 ¼" competition billiard balls
- Two 57" two-piece hardwood cues
- Two pieces of performance chalk
- One resin triangle

SOME ASSEMBLY REQUIRED



MODERN SIDE BALL RETURN



TRUESHOT

6 ft. FOLDABLE BILLIARD TABLE **64-6035**

For quick and easy fun, there's none better than the Trueshot billiard table with foldable legs. This innovative design couples compact design with surprising portability. For those that are tight on space and want to enjoy their favorite classic table game, the Trueshot is the perfect solution! Featuring high strength material means not sacrificing quality for space, as the surface of the Trueshot table will be sure to play smooth and fast. Featuring a sleek black cloth design, this table will complement any decor.

DIMENSIONS	76"L x 43.25"W x 32"H
PLAYFIELD DIMENSIONS	66"L x 31.5"W
SHIPPING CARTON	78"L x 45.25"W x 3.75"H
NET WEIGHT*	114.4 lbs
GROSS WEIGHT**	127.6 lbs
SHIPPING WEIGHT***	197 lbs
WARRANTY	90 day

FEATURES

- Compact design allows you to enjoy your favorite game in spaces you never thought possible.
- Sleek black cloth complements any room decor, from traditional to contemporary.
- High quality building materials allow for lightweight play and portability without sacrificing strength.
- The perfect size for younger players learning the fun of pool.
- Locking leg safety features ensure a fun filled game without any worry.

ACCESSORIES

- Two pieces of performance chalk
- One resin triangle
- One resin table brush
- Two 57" two-piece hardwood cues
- One set of 2 1/4" competition billiard balls

SOME ASSEMBLY REQUIRED



SPACE SAVING FOLDING DESIGN

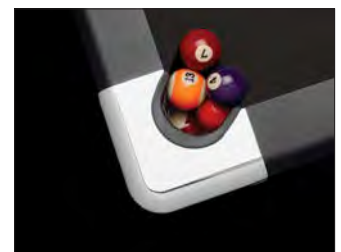

MODERN DROP POCKETS



FOLDABLE AND SAFE LOCKING LEGS



EXCLUSIVE LATCH SYSTEM
GLD® uses a latch table lock system exclusively designed for our Pockey tables. It is user friendly and more structurally supportive than tables using a pin system.

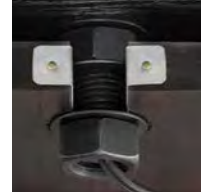

POWER CORD CHANNEL
Exclusive to GLD, the power cord channel is placed through the spindle on the end of the Pockey table to help prevent damage to your table, cord and outlet.



STORAGE RACK

PORTABLE TABLE TENNIS



7 ft. POCKEY®

3-in-1 GAME TABLE

- GREEN **64-1046**
- NEW** BLUE **64-1052**
- NEW** RED **64-1053**
- NEW** TAN **64-1054**

All of the most popular games are now at your disposal, in a third of the space with the Fat Cat® 3-in-1 Pockey table! This revolutionary multi-game table design offers an unprecedented three of the most popular game room games that would normally take up the space of three separate tables in a single unit! Your family will be in for hours of fun flipping between the different games the Pockey table has to offer! Each table surface is optimized for its game, ensuring a great experience no what game you play.

DIMENSIONS	87"L x 44"W x 32"H
SHIPPING CARTON	92"L x 56"W x 12"H
NET WEIGHT*	286 lbs
GROSS WEIGHT**	317 lbs
SHIPPING WEIGHT***	420 lbs
WARRANTY	90 day

TABLE OVERALL FEATURES

- Exclusive GLD® Latch System and GLD Power Cord System
- Adjustable leg levelers
- Billiard cue, ball, puck, pusher and accessory storage for all your items

TABLE HOCKEY FEATURES

- Playfield size: 74"L x 38"W
- 110V motor with the air flow of 80 ft³ per minute
- Manual scoring system
- Glossy white playing surface features colors and lines to resemble an ice hockey rink
- High output blower creates a thicker cushion of air to keep the puck in motion

BILLIARD FEATURES

- Playfield size: 70"L x 34"W
- Playing surface features Tetolon cloth, rubber bumpers, and drop pockets

TABLE TENNIS FEATURES

- Playfield size: 80.25"L x 42"W x 0.25"H
- Tri-fold table top for compact storage

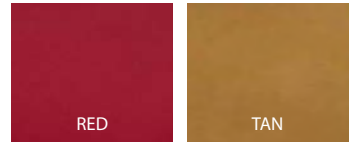

4 FELT COLOR OPTIONS

ACCESSORIES

- Convenient storage rack for accessories
- Four ultra-impact pushers and four lightning-strike reduced friction pucks
- One set of 2 1/4" competition billiard balls
- One resin triangle
- Two 57" hardwood cues
- One billiard brush
- Two pieces of performance chalk
- Two table tennis paddles and two high-speed balls
- One net and post set

US Patent #7785208 B2, 7762902 B2, and 7967694

SOME ASSEMBLY REQUIRED



CUE STORAGE RACKS



7 ft. POCKEY®

2-in-1 GAME TABLE **64-1010**

All of the most popular games are now at your disposal, in a third of the space with the Fat Cat® 2-in-1 Pockey table! This revolutionary multi-game table design offers an unprecedented two of the most popular game room games that would normally take up the space of two separate tables in a single unit! Your family will be in for hours of fun flipping between the different games the Pockey table has to offer! Each table surface is optimized for its game, ensuring a great experience no what game you play.

DIMENSIONS	87"L x 44"W x 32"H
SHIPPING CARTON	92"L x 56"W x 12"H
NET WEIGHT*	272 lbs
GROSS WEIGHT**	287 lbs
SHIPPING WEIGHT***	380 lbs
WARRANTY	90 day

TABLE HOCKEY FEATURES

- Playfield size: 74"L x 38"W
- 110V motor with the air flow of 80 ft³ per minute
- Manual scoring system
- Glossy white playing surface features colors and lines to resemble an ice hockey rink
- High output blower creates a thicker cushion of air to keep the puck in motion

BILLIARD FEATURES

- Playfield size: 70"L x 34"W
- Playing surface features Tetolon cloth, rubber bumpers, and drop pockets

TABLE OVERALL FEATURES

- Exclusive GLD Latch System and GLD Power Cord System
- Adjustable leg levelers

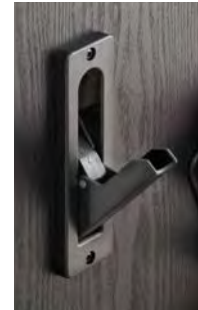

EXCLUSIVE LATCH SYSTEM

GLD® uses a latch table lock system exclusively designed for our Pockey tables. It is user friendly and more structurally supportive than tables using a pin system.



POWER CORD CHANNEL

Exclusive to GLD, the power cord channel is placed through the spindle on the end of the Pockey table to help prevent damage to your table, cord and outlet.

ACCESSORIES

- Convenient storage rack for accessories
- Four ultra-impact pushers and four lightning-strike reduced friction pucks
- One set of 2 ¼" competition billiard balls
- One resin triangle
- Two 57" hardwood cues
- One billiard brush
- Two pieces of performance chalk

US Patent

#7785208 B2, 7762902 B2, and 7967694

SOME ASSEMBLY REQUIRED



FLIP GAME TABLE TOPS IN AN INSTANT



FLIP GAME TABLE

3-in-1 GAME TABLE **64-1049**

The Fat Cat® Original Flip game table is the perfect table for someone hoping to maximize the fun-to-space ratio in their game room. The three surfaces are all well-made and will serve their purposes well. The billiards playing surface features green velvet cloth and drop pockets. The table tennis surface is made of 3/8" electric blue surface with printed table tennis lines. The air hockey surface features a 9mm air channel and a glossy white surface made to resemble an ice hockey rink.

DIMENSIONS	72"L x 32"W x 32"H
PLAYFIELD DIMENSIONS	60"L x 27"W
SHIPPING CARTON	70"L x 40"W x 12"H
NET WEIGHT*	141 lbs
GROSS WEIGHT**	152 lbs
SHIPPING WEIGHT***	220 lbs
WARRANTY	90 day

BILLIARD FEATURES

- Playfield size: 60"L x 27"W
- Real rubber bumpers for an authentic bounce
- Covered in heavy duty evergreen cloth
- Six inset pockets

TABLE HOCKEY FEATURES

- 9mm Air channel powered table hockey
- Extra glossy playing surface features hockey rink graphics
- Convenient space-saving table flips from billiards to table hockey in an instant
- Full-powered 220V electric motor

TABLE TENNIS FEATURES

- Convenient slide-on table tennis top usable on either side
- 3/8" Electric blue surface with printed table tennis lines

ACCESSORIES

- Convenient storage rack for accessories
- Four ultra-impact pushers and four bounce-back pucks
- One set of small billiard balls
- One resin triangle
- Two 48" cues
- One billiard brush
- Two pieces of performance chalk
- Two table tennis paddles and two high-speed balls
- One net and post set

SOME ASSEMBLY REQUIRED

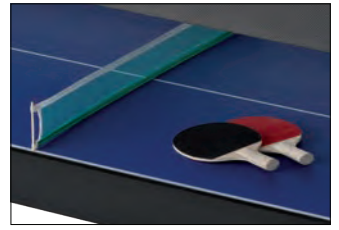

STORAGE FOR TABLE TENNIS TOP



STORAGE FOR ACCESSORIES

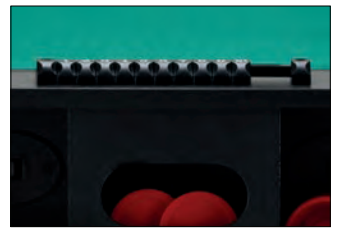

ABACUS SCORING



Fat Cat
VOLT

7 ft. LED AIR HOCKEY TABLE **64-3014**

The newest innovation in air hockey is the Fat Cat® Volt with exclusive LED illuminated play-field! The Volt features exciting new play-field graphics that will invoke the feeling of fierce competition. With a powerful motor supplying a generous cushion of air, the Volt plays faster than any table that has come before it. This all-new table features an exclusive LED lightning system that gives each game a unique experience from other tables. The LED display syncs with the Volt music system that tells the story of the game and flashes bright when players score. Your game room will never be the same!

DIMENSIONS	83"L x 42"W x 31"H
PLAYFIELD DIMENSIONS	77"L x 35.25"W
SHIPPING CARTON	92"L x 56"W x 11.5"H
NET WEIGHT*	120 lbs
GROSS WEIGHT**	139 lbs
SHIPPING WEIGHT***	247 lbs
WARRANTY	90 day

FEATURES

- Built-in LED strips light up the playfield
- Synchronized lighting displays
- Specially designed graphics highlighted by LED light system
- Fine-tuning leg levelers
- 110V Motor with air flow of 80 ft³ per minute
- Ultra-smooth rink that allows the pucks to reach extreme speeds
- One LED electronic scorer
- Quick playing surface allows your puck to reach lightning speeds
- Dual end puck returns keep the game moving fast and located directly under each goal

ACCESSORIES

- Two ultra-impact pushers
- Two lightning-strike reduced friction pucks

SOME ASSEMBLY REQUIRED



CONVENIENT LED SCORER



FAST PLAY DUAL END PUCK RETURN



ULTRA-SMOOTH QUICK-ACTION SURFACE



STORM MMXI

7 ft. AIR HOCKEY TABLE **64-3011**

The Fat Cat® Storm MMXI is a great addition to any game room or living room. At an air flow rate of 80 ft³ per minute, this table will provide steady puck support for smooth hovering! The table features a smooth, white playing surface and colorful graphics. The table is equipped with an LCD electronic scorer that supplies the score as well as entertaining audio for a more dynamic air hockey experience.

DIMENSIONS	84"L x 42"W x 30.5"H
PLAYFIELD DIMENSIONS	73.75"L x 36"W
SHIPPING CARTON	92"L x 56"W x 11"H
NET WEIGHT*	146 lbs
GROSS WEIGHT**	163 lbs
SHIPPING WEIGHT***	247 lbs
WARRANTY	90 day

FEATURES

- 5" Fine-tuning leg levelers
- 110V motor with air flow of 80 cubic feet per minute
- Ultra-smooth rink that allows the pucks to reach extreme speeds
- Colorful signature flame graphics add excitement to the Storm's rink
- One LED electronic scorer (3AAA batteries not included)
- Quick playing surface allows your puck to reach lightning speeds
- Dual end puck returns keep the game moving fast and located directly under each goal

ACCESSORIES

- Two ultra-impact pushers
- Four lightning-strike reduced friction pucks

SOME ASSEMBLY REQUIRED



CONVENIENT LED SCORER



FAST PLAY DUAL END PUCK RETURN

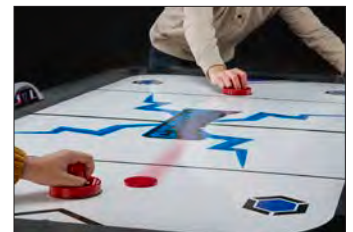

ULTRA-SMOOTH QUICK-ACTION SURFACE



REBEL

FOOSBALL TABLE **64-0913**

Complete the look of your game room with the classic style of the Fat Cat® Rebel foosball table. The Rebel features a timeless design on a new body, combining traditional and modern looks. With its Vintage colors on a modern design, the Rebel is sure to complement most decors. The Rebel features new play features as well, foremost of which are the Quick Snap player rods, which get you playing your favorite game right out of the box. Completing the Rebel are highly detailed soccer style foosballs and men.

DIMENSIONS	54"L x 31"W x 29.5"H
SHIPPING CARTON	60.63"L x 33.1"W x 5.9"H
NET WEIGHT	73.7 lbs
GROSS WEIGHT	86 lbs
SHIPPING WEIGHT W/ PALLET	120 lbs
SHIPPING WEIGHT (CARTON ONLY)	87 lbs
WARRANTY	90 day

FEATURES

- Quick Snap player rods make setup a breeze, get into the game fast!
- Classic blue-gray color scheme complements most room decor, contemporary or traditional.
- Solid ¼" wooden walls are built with durability in mind, for long-lasting fun.
- High definition playfield graphics add a new level of depth to games.
- Quick Snap rods feature Soccer Style players
- Black leg levelers

ACCESSORIES

- 4 Soccer style foosballs

SOME ASSEMBLY REQUIRED



TRADITIONAL SOCCER STYLE PLAYERS



QUICK SNAP PLAYER RODS



TIRADE MMXI

FOOSBALL TABLE 64-0908

The Fat Cat® Tirade MMXI is a great addition to any game room or living room. The back walls can be removed to reveal an innovative way to keep play flowing. Behind the walls is a curved wall that will project any balls that miss the net back into play. The table has a traditional, block-style design and is equipped with a ¼" black, laminated playing field with logos. The black and ivory players are installed on tournament-size ¾" hollow steel player rods with pro-hand grips. The table is also equipped with a traditional abacus scoring system as well as leg-levelers to ensure table is completely even on most surfaces.

DIMENSIONS	55"L x 34"W x 34"H
SHIPPING CARTON W/ PALLET	60"L x 30"W x 12"H
SHIPPING CARTON	57"L x 30"W x 7"H
NET WEIGHT	99 lbs
GROSS WEIGHT	119 lbs
SHIPPING WEIGHT W/ PALLET	155 lbs
SHIPPING WEIGHT (CARTON ONLY)	120 lbs
WARRANTY	90 day

FEATURES

- ¼" Black, laminated playing field with logos
- 13 ¾" aprons
- Black and ivory playing men
- 4 ½" Post style legs with chrome leg levelers
- Tournament size ¾" hollow steel player rods with pro hand grips
- Traditional block style design
- Convenient side ball returns
- Metal professional soccer goals
- Manual abacus scorer
- Curved playwave keeps ball in play

ACCESSORIES

- 4 Soccer style foosballs

SOME ASSEMBLY REQUIRED



FAST PLAY BALL RETURN

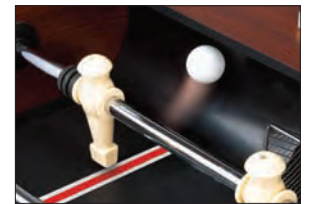

CONTINUOUS PLAY



PORTABLE TABLE TENNIS TOP

PORTABLE TABLE TENNIS 64-1006

Take all the fun of fun competition anywhere you go with the Viper® Portable Table Tennis Table Top! This revolutionary design allows you to take your favorite game to places you never thought before! The Viper® Table Top can be placed on dining tables, kitchen islands or used to convert pool tables or air hockey tables. The tri-fold table is made from medium density wood for excellent durability while maintaining a lighter weight for ease of transport. The portable table tennis top is not only fun for table tennis, but on the reverse side the table top features screen printed checker, chess, and backgammon boards for additional ways to play!

DIMENSIONS	84"L x 42"W x 0.25"H
CARTON DIMENSIONS	47.75"L x 33.25"W x 3.63"H
NET WEIGHT*	30 lbs
GROSS WEIGHT**	40 lbs
WARRANTY	90 day

FEATURES

- Tri-fold table top for compact storage
- Lightweight construction for easy toting
- Top has Table top chess, checkers and backgammon
- Set up and play in seconds on any flat surface

ACCESSORIES

- One table tennis net & post set
- Two paddles
- Two table tennis balls
- Chess pieces
- Backgammon/checker pieces
- Portable canvas carrying case with side pocket and carrying handles

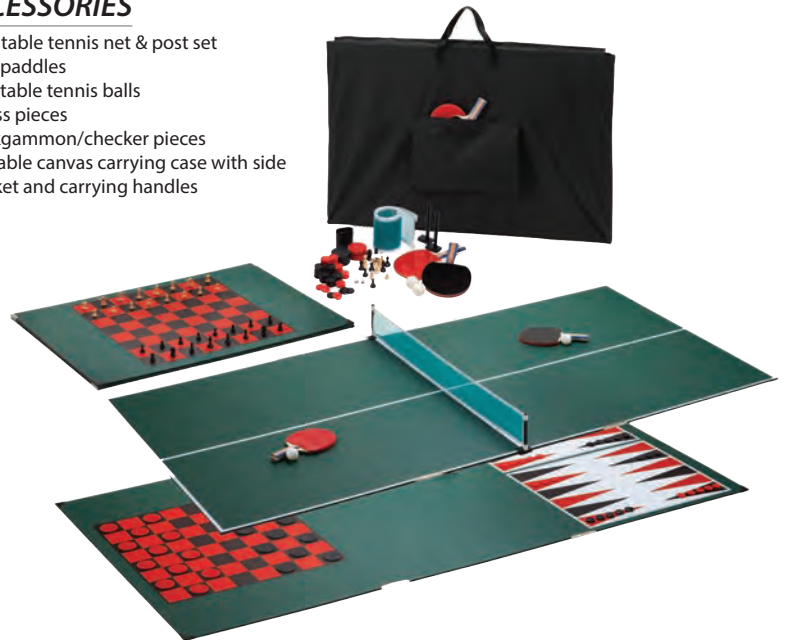

TABLE TENNIS ACCESSORIES **VIPER**

THE GLIDE ONE-STAR

70-3000

For the amateur player who plays for fun

SPIN 26
SPEED 27
CONTROL 99



MAX TRAJECTORY TWO-STAR

70-3010

For the player with some playing experience

SPIN 42
SPEED 52
CONTROL 93



MAX MOMENTUM TWO-STAR

70-3015

For the player with some playing experience

SPIN 42
SPEED 52
CONTROL 93



ORBITAL VELOCITY THREE-STAR

70-3210

For the player who wants to improve their game

SPIN 52
SPEED 72
CONTROL 71

ITTF approved



LEADING EDGE FOUR-STAR

70-3110

For the advanced player skilled in playing techniques and tactics

SPIN 72
SPEED 81
CONTROL 67

ITTF approved



TWO PADDLE SET TWO-STAR

70-2000

For two players with some playing experience

SPIN 42
SPEED 52
CONTROL 93

Two rackets and three balls



FOUR PADDLE SET TWO-STAR

70-2005

For four players with some playing experience

SPIN 42
SPEED 52
CONTROL 93

Four rackets and six balls



1 STAR TABLE TENNIS BALLS

70-1000

- Six precision table tennis balls
- Great quality for family play
- Offers consistent bounce
- Durable play
- 40mm Regulation size



3 STAR TABLE TENNIS BALLS

70-1010

- Six precision table tennis balls
- Professional quality for competitive play
- Offers excellent bounce and spin control
- Long lasting play
- 40mm Regulation size

FOOSBALL ACCESSORIES **Fat Cat**



INLAID FOOSBALLS

27-0209

- Four per card
- Sold in 12 packs
- 36mm



FOOSBALLS

27-0208

- Four per card
- Sold in 12 packs
- 36mm



24 PACK TABLE TENNIS BALLS

70-1020

- Twenty-four table tennis balls
- Great for the family rec room and playing for fun
- 40mm Regulation size

INDEX

VIPER BLACK SOFT-TIP

NEW Flux Conversion 4, 32

VIPER® SOFT-TIP

Astro 8
Atomic Bee 29
Black Ice 21
Black Magic 20
Bobcat 18
Bully 14
Comix 22
Commercial Bar Dart 30
Desert Rose 16
Desperado 6
Diamond 11
Element 13
Elite Brass 27
Grim Reaper 12
Jaguar 7
Mighty Mite 30
Pitbull 5
Ranger 15
Sidewinder 15
Sinister 10
Silver Thunder 26
Spinning Bee 29
Super Bee 28
Sure Grip 25
Termite 30
The Freak 19
Tungsten Bee 28
Underground 24
Vanity 17
V-Factor 9
V Glo 17
Wind Runner 23
Wings 16
Wizard 20

FAT CAT® SOFT-TIP

Blazer 51
Bulletz 48
Darts in a Jar 49
Deluxe 51
Highlander 52
Pink Lady 49
Realtree APC® 50
Realtree Xtra® 50
NEW Support Our Troops 48
Warrior 52

LASERDART® SOFT-TIP

Black Widows™ 71
Gold Widows™ 71
Silver Widows™ 71

ELKADART® SOFT-TIP

Black Mamba 62
Lone Wolf 63
Neon 64
Orbital 64
Rainbow 60
Razor 62
Storm 65
Titanium 61
Tornado 60
Turbo 65
Ultra Sonic 61
Wizard 63

VIPER BLACK STEEL-TIP

NEW Flux Conversion 4, 32

VIPER® STEEL-TIP

Black Mariah 46
Blitz 33
Bully 36
Cold Steel 38
Comix 43
Commercial Bar Dart 46
Desperado 35
Elite Brass 45
Jackal 37
Sidewinder 39
Silver Thunder 44
Sinister 34
The Freak 41
Underground 42
V-Factor 36
Vanity 40

FAT CAT® STEEL-TIP

Beer Darts 58
Blazer 57
Bulletz 54
Darts In A Jar 54
Deluxe 57
Highlander 59
Predator 53
Realtree APC® 55
Realtree Hardwoods HD® 55
Support Our Troops 56
Twin Pack 56
Warrior 58

LASERDART® STEEL-TIP

Black Widows™ 71

ELKADART® STEEL-TIP

Black Mamba 66
Black One Fifty 69
Lone Wolf 69
Orbital 70
Prism 70
Rainbow 66
Razor 67
Rhino 67
Ultra Sonic 68
Wizard 68

FLIGHTS

Alchemy 78
Amazon 78
Assorted Flight Bags 79
Commercial Bar Flight 30, 46, 78
Cool Molded 73
Dimplex® 77
Flight Card 79
Laserdarts® Widows Flight Shaft 78

NEW American Flag 73

NEW Patriot Pack 79

Pentathlon 77
Pentathlon 180s 78
Pentathlon HD 78
Specialty Flights 78
V-75 76
V-75 Lux 76
V-100 75

NEW V-100 Dimplex® Hybrid 74

NEW V-100 Flux 73

V-100 Lumacore 74

V-100 Oryx 75

V-100 Sinister 74

NEW V-100 Sinister Skulls 74

NEW V-150 73

V-Riptex 76

SHAFTS

AL-XIII Aluminum Shaft 83
Aluminum Shaft 83
Carbon Plus Shaft 82
Color Master Shaft 82
Diamond Cut Shaft 83
Nylon Shaft 81
Shockwave Shaft 81
Spider Leg™ Shaft 83
Spin Shaft 82
Spinster™ Aluminum Shaft 82

Spinster™ Yukon Shaft 82

Starburst Shaft 82

V Glo Shaft 17, 82

Viperlock Aluminum Shaft 80

Viperlock Shaft 81

Viperlock Shade Shaft 81

Wire Shaft 83

TIPS

¼" Tufflex Tips® II 84

2BA Tufflex Tips® II 84

2BA Tufflex Tips® III 84

2BA Tufflex Tips® S.S. 84

Colossal Jar of Tips 84

Converter Points 85

Diamond Tips 84

Sinister™ Converter Points 84

Steel Tip Converter Points 85

VIPER®/ELKADART® ACCESSORIES

2"× 3" Printed Bags 85

3 Dart Display 85

Add-A-Grams 85

Bar Dart Replacement Barrels/Flights 30

Blank Hangsell Case 85

Broken Shaft Remover 80

Dart Mechanic Wrench 80

Dartboard Hanging Kit 80

Elkadart® O-ring Applicator 80

Elkadart® Shaft Remover 80

Flight Protector Kit 79

Flight Protectors 79

Flight Punch 79

Large Accessory Box 85

O-Rings 79

Pins 85

Replacement Tube 97

Rosin Bag 85

Shaft Lock Kit 80

Shaper Stone 79

Small Accessory Box 85

Stem Rings 79

Sure Grip Replacement Sleeves 25

Viperlock Shaft Rings 79

FAT CAT® ACCESSORIES

2BA Tufflex Tips® II 59

Aluminum Shafts 59

Assorted Flights 59

Dart Washers 59

Dart Point Shaper 59

Tip Remover 59

CASEMASTER® DART CASES

Accolade 93
Classic 94
Deluxe 96
Elite Jr. 95
Legion 92
NEW Nomad 86
Plazma 88
Plazma Plus 88
Plazma Pro 89
Printed Deluxe Dart Pal® 97
Select 95
Sentry 91
Sentinel 90
NEW Sentinel American Flag 90
NEW Sentinel Art Series 87
Single 96
Sinister™ Aluminum 92
Sole 93
NEW Sport 89
Small Storage Tube 97
Ternion 93
The Pro 94
Unprinted Deluxe Dart Pal® 97
Warden 91

DARTBOARDS & CABINETS

727 111
777 108
787 107
797 106
800 105
850 99
Aim 360 Sisal Dartboard 113
Chroma Sisal Dartboard 114
Dead-On Sisal Board 116
Double Play Fiber Dartboard 116
ElectronX 110
Hideaway 117
Hudson All-In-One Dart Center 122
Ion 100
League Sisal Board 115
League Pro Sisal Board Set 115
Mercury 109
Metropolitan Soft-Tip Cabinet 123
Metropolitan Steel-Tip Cabinet 124
NEW Obsidian 112
Orion 101
Neptune 103
Razorback Sisal Board 113
Resolute 125
Shot King® Sisal Board 114
Showdown 102

Sirius 111
Slash 112
Solar Blast 104
Stadium 118
Steadfast 125
Vault 119
Vault Deluxe with ProScore 120
NEW Vault Deluxe with Shot King 121

DARTBOARD ACCESSORIES

Championship Backboard Set 126
Dart Caddy 134
Dartboard Adapter 99-110
Dartboard Backboard 126
Dartboard Leveler Kit 135
Defender 130
Defender Cork 128
Defender II 130
Defender II Cork 129
Defender III 131
Defender III Cork 129
Dry Erase Marker 132
EVA V-Foam Backboard 131
Guardian Dartboard Surround 128
NEW Illumiscore 133
Laser Dart Line 137
Laserlite 137
Magnetart Holsters 135
Padded Non-Slip Dart Mat 136
Pro Line 136
NEW Pro Sisal Dartboard Centers 127
ProScore 132
Shadow Buster 134
Scoreboards 132
NEW Throw Line Markers 138
NEW Quickfit 135

VIPER® CUES

Clutch 147
Colours 146
Commercial One Piece 158
Diamond 152
Desperado 140
Elementals 145
Elite 155
Graphstrike™ 153
Hot Pink 157
Junior 156
Jump Break Black Cue 157
Pink Lady 157
Naturals 141
Revolution 142
Revolution Sure Grip Pro 148
Signature 154

Sinister 143 - 144
Sneaky Pete ZebraWood Cue 157
NEW Underground 149 - 151

CASEMASTER® BILLIARD CASES

Classic Q-Vault 160 - 161
Cono Case 162
Deluxe Hard Case 162
NEW Parallax Case 159
Realtree Hardwoods® 162
Supreme Q-Vault 160 - 161

BILLIARD ACCESSORIES

9-Ball Rack 164
Cone Chalk Holder 163
Cone Chalk 163
NEW Cue Joint and Tip Protector 163
Cue Joint Protectors 163
Cue Racks 163-164
Cue Replacement Bumper 163
Cue Wrench 164
Deluxe Cone Chalk Holder 163
Master Pool Balls 163
Scuffer Bumper 164
Silvercup® Blue Chalk 163
NEW Silvercup® Black Chalk 163
NEW Silvercup® Burgandy Chalk 163
Silvercup® Green Chalk 163
NEW Silvercup® Tan Chalk 163
Silvercup® Talc Powder 163
Table Cover 163
Triangle Ball Rack 164
Weight Bolt System 164

HOME CASINO

Bling Poker Chip Set 168
Card Shoe 169
Dice Cup 169
Poker Chip Tray 169
Poker/Blackjack Table Top 167
Texas Hold'em Poker Chip Case 169
Texas Hold'em Poker Chip Set 168
Texas Hold'em Poker Table 166
Texas Hold'em Poker Top 167

MAINSTREET CLASSICS®

29 Cribbage Board 173
35" Table Hockey Table 177
36" Foosball Table 176
42" Table Hockey Table 177
Broadway Combo Set 171
Barony Cribbage Board 173
Classic 20" Backgammon Set 172
Classic 23" Backgammon Set 171

Dutchman Wood Game Set 174
Micro Bag Toss 174
Pennsylvania Ave Backgammon Set 172
Sinister™ Table Top Table Hockey 175
Sinister™ Table Top Billiards 175
Sinister™ Table Top Foosball 176

TABLE GAMES

7 ft. Pockey® Table 184
7 ft. Pockey® Table w/Table Tennis Top 183
Frisco II 180
Flip Game Table 185
Portable Table Tennis Top 189
Rebel 188
Reno II 179
Storm MMXI 187
Tirade MMXI 189
Trueshot 182
Tucson MMXI 181
Volt 186

TABLE GAME ACCESSORIES

Foosballs 190
Paddles 190
Table Tennis Balls 190

PLACING ORDERS

Orders may be placed by telephone, fax, e-mail, regular mail, or soon via our website.

NEW ACCOUNTS

If this is your first time placing an order with GLD Products, please have the following information available: Company name, bill to and ship to addresses, phone and fax numbers, email, and either Federal Tax ID Number or State Reseller Certificate Number. We'll need a copy of one of these ID numbers as well. To apply for credit terms with GLD, you will need to complete all sections of the credit application you can get from your account rep. Open accounts and COD payment by company check must have prior approval.

TERMS

Returned checks will incur a \$35.00 fee and your account will be placed on COD cash only. We accept MasterCard, VISA, AmEx, Discover and PayPal.

BACKORDERS

Items not available at the time of your order will be placed on backorder. When stock arrives we will call you to see if you still wish to have the items shipped. Be aware shipping costs will be incurred. You can add to the order before we ship the backordered item(s).

MINIMUM ORDER QUANTITIES

All items should be ordered in multiples of the minimum order quantity. Orders not meeting this qualification may be subject to an upcharge.

SHIPPING

Unless specified our staff will determine the best method to ship your order. Next day or second day orders received before 10AM CST will be shipped the same day. Shipping charges are billed on your invoice FOB Muskego, WI 53150. Ground shipments will be shipped in the order they are received. Shipping errors must be reported within 5 business days of receipt of shipment for RA and/or credit.

TRUCK ORDERS

Freight delivered by common carrier must be inspected before signing as received. If cartons are damaged or missing this must be noted on the bill of lading, or the entire shipment refused. Failure to do so may result in failure to receive credit. Claims cannot be filed if shortages or damage is not noted on the bill of lading.

RETURNS

Please call for approval and a Return Authorization Number

Toll Free 800.225.7593

Local 262.679.8730

Merchandise returned will be inspected by a GLD representative. If for any reason the item(s) returned to GLD is in such a fashion as to not be able to be placed back into stock, the item(s) will be returned to you and no credit issued. Any returned item(s) that passes inspection will be charged a 15% restocking fee.

WHEN RETURNING PRODUCT

Please include the following information:

- Return authorization number
- Invoice number and date
- Client number
- Product number
- Reason for return

All returns must have a Return Authorization Number (RA#). To receive an RA# please contact your customer service representative with the reason for the return. Clearly mark the RA# on the shipping label. We reserve the right to refuse to credit items returned without an RA#. Any items returned without prior approval will be returned to the sender at the sender's expense. RA's will remain open for a period of 30 days from the date of issue. Product must be returned within this time period to insure acceptance of product and proper credit to your account. Open RA's will be canceled after 30 days if product(s) has not been received.

DAMAGED GOODS SHORTAGES

If any items are damaged or missing from the carton(s), please report this to us within 5 working days of receipt of the shipment. If you receive damaged or open carton(s), a separate claim must be filed with the carrier within 5 business days. Be sure to sign your shipping documents "subject to inspection and verification" upon receipt of such carton(s).

OTHER

GLD Products has a policy of continuous product improvement. Product specifications may change without prior notification.

www.gldproducts.com
support@gldgames.com



(262) 679-8730
(800) 225-7593



(262) 679-8738
(800) 841-6944



Great Lakes Dart Mfg., Inc
S84 W19093 Enterprise Drive,
Muskego, WI 53150 USA



VIPER[®]

Fat Cat[®]

CASEMASTER[®]

MAINSTREET[™]
Classics