

NOTES:  
 1. MATERIAL: .015 TK BRIGHT 430 STAINLESS STEEL

CUSTOMER DRAWING

This drawing is the property of Rev-A-Shelf (RAS) and is disclosed in confidence to the extent its subject matter is original to RAS. Any vendor receiving this drawing from RAS shall hold and use this drawing for the sole benefit of RAS and shall not disclose it to, or use or reproduce it for any third party, or perform any act adverse to the interest of RAS with respect to this drawing without the express written permission of RAS. Vendors shall not revise any physical, dimensional or performance characteristic unless authorized by Rev-A-Shelf Engineering.

REV.	DATE	BY	DESCRIPTION OF CHANGE

INCH [MM]	AMERICAN PROJECTION 	DRAWN	BY	DATE	REV-A-SHELF, INC.	
			BKT	7/29/14		
		MATERIAL		DRAWING NO.		SCALE
		FINISH		PART NO.		SHEET OF
TOLERANCES MAT. DEC. (WOOD) .XX ±.03 [.8mm] (OTHER) .XX ±.02 [.5mm] (ALL) .XXX ±.005 [.13 mm] FRACTIONS ±1/32 [.8 mm]		ANGLES ±1/2°		SIZE <b>B</b> SLIM 11.25" STAINLESS STEEL TIP OUT TRAY		1.000
				6541-20-1104		1 2
				6541-20-1104		

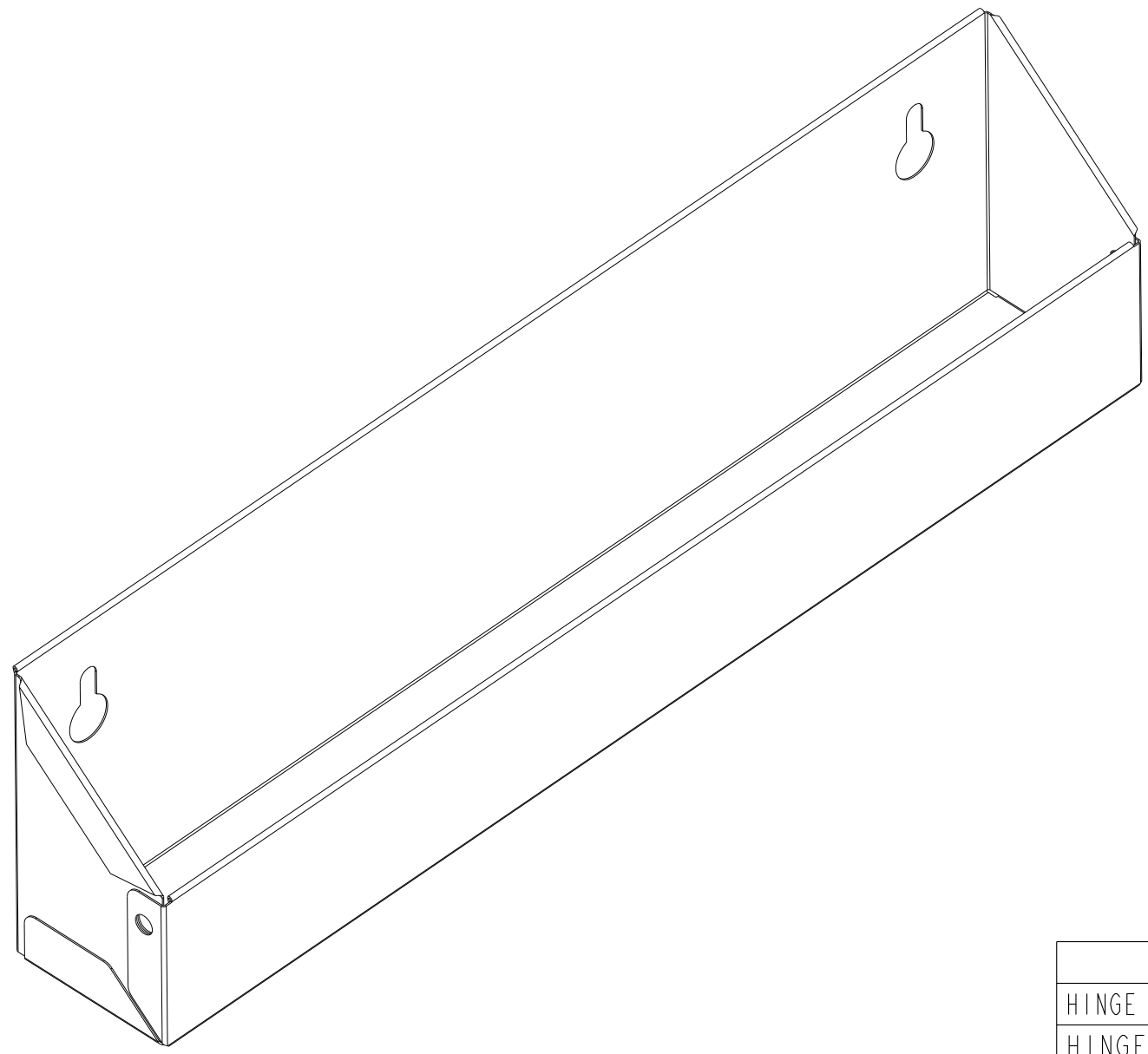

PART DIMENSIONS	
WIDTH	11.25 [285,8]
DEPTH *	1.69 [43,1]
HEIGHT **	3.00 [76,2]

\* DEPTH W/ SELF-HOLDIN HINGES: 1.77 [45]  
 \*\* HEIGHT W/ SELF-HOLDIN HINGES: 3.80 [96,5]

MIN CABINET OPENING ***				
	FACE FRAME	FRAMELESS	INSET FACE FRAME	INSET FRAMELESS
WIDTH	13.50 [343]	13.50 [343]	13.50 [343]	13.50 [343]
DEPTH	2.00 [50,8]	2.00 [50,8]	2.75 [69,9]	2.75 [69,9]
HEIGHT	3.88 [98,4]	3.88 [98,4]	3.88 [98,4]	3.88 [98,4]

\*\*\* MCO BASED ON SELF-HOLDIN HINGES

HINGE SPECIFICATIONS				
HINGE PART NUMBER	HA 94-MZ	RELEASE PART NUMBER	N/A	MAX WEIGHT RATING
HINGE TYPE	PIVOT	HINGE EXTENSION	45°	
HINGE CLOSING	N/A	HINGE LENGTH	N/A	N/A
HINGE MOUNTING	SIDE	HINGE FINISH	ZINC	

CUSTOMER DRAWING

This drawing is the property of Rev-A-Shelf (RAS) and is disclosed in confidence to the extent its subject matter is original to RAS. Any vendor receiving this drawing from RAS shall hold and use this drawing for the sole benefit of RAS and shall not disclose it to, or use or reproduce it for any third party, or perform any act adverse to the interest of RAS with respect to this drawing without the express written permission of RAS. Vendors shall not revise any physical, dimensional or performance characteristic unless authorized by Rev-A-Shelf Engineering.

REV.	DATE	BY	DESCRIPTION OF CHANGE

INCH [MM] 	AMERICAN PROJECTION	DRAWN	BY	DATE	
	TOLERANCES MAT. DEC. (WOOD) .XX ±.03 [.8mm] (OTHER) .XX ±.02 [.5mm] (ALL) .XXX ±.005 [.13 mm] FRACTIONS ±1/32 [.8 mm]	ANGLES ±1/2°	BKT	7/29/14	
MATERIAL			DRAWING NO.		SCALE
FINISH			PART NO.		SHEET OF
			6541-20-1104		0.750
			6541-20-1104		2 2