

HEKMAN®

A HOWARD MILLER COMPANY
Grand Rapids, Michigan

INSTALLATION INSTRUCTIONS

Pattern Description 25623 is the side chair

DO NOT SCALE SKETCHES







COPYRIGHT 1997 HEKMAN FURNITURE COMPANY

Pattern Number(s)

25623

Drawn By AMY

Date 12/09/21

PARTS			Q' TY
A		5/16*1-1/2"	1
B		5/16*3-1/4"	4
C		5/16 "	9
D		5/16 "	9
E		5/16 "	4
F		13MM	1
G		5/16"	1

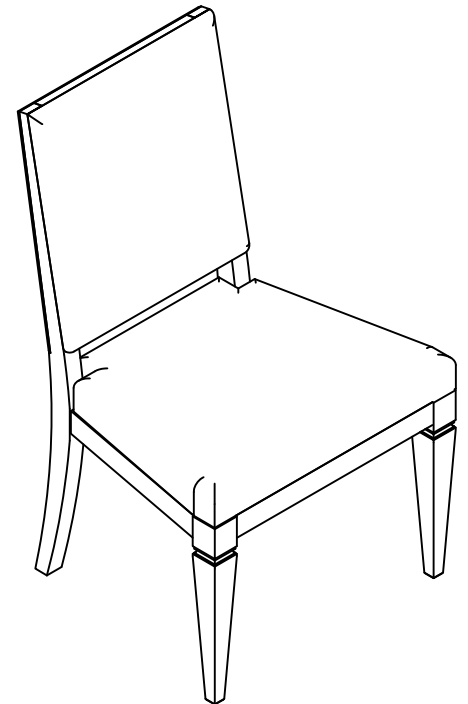
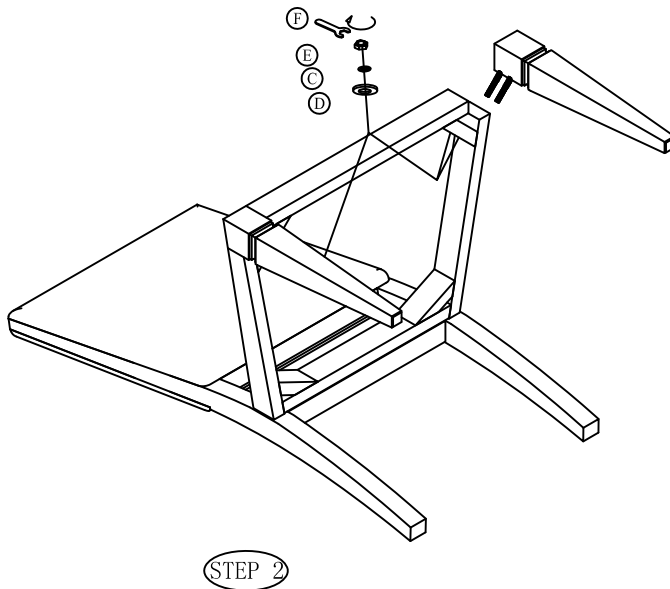
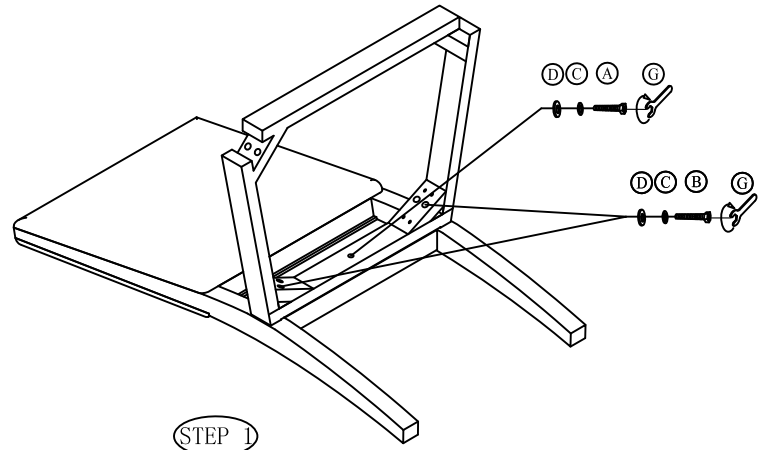

TO ASSEMBLE: (Two people required)

Step 1: Place the Chair Back on a padded surface, and assemble the Chair Seat frame to the Chair Back (as shown in Step 1), using one short bolts (A) and four long bolts (B) with five lock washers (C) and five flat washers (D) tighten with the wrench (G). Do not fully tighten any bolts until after chair has been completely assembled.

Step 2: Attach both front legs to the seat frame using four nuts (E), and four lock washers (C) and four flat washer (D) Tighten with the wrench (F).

Step 3: Set the chair on a flat surface to ensure all four legs touch the floor, then tighten all bolts and nuts.

(STEP 3)