



Owner's Manual

Model
CDFI-BX1000
6909910100









IMPORTANT SAFETY INFORMATION: Always read this manual first before attempting to install or use the Opti-myst® Pro Box Heater. For your safety, always comply with all warnings and safety instructions contained in this manual to prevent personal injury or property damage.

To view the full line of Dimplex products, please visit www.dimplex.com

7215020100R02



Table of Contents

 Welcome & Congratulations	3
 IMPORTANT INSTRUCTIONS	4
 Installation	6
 Operation	11
 Maintenance	12
 Warranty	13
 Technical Support	15

Always use a qualified technician or service agency to repair this unit.

! NOTE: Procedures and techniques that are considered important enough to emphasize.

⚠ CAUTION: Procedures and techniques which, if not carefully followed, will result in damage to the equipment.

⚡ WARNING: Procedures and techniques which, if not carefully followed, will expose the user to the risk of fire, serious injury, or death.

Welcome & Congratulations

Thank you and congratulations for purchasing an Opti-myst Pro Box Heater from Glen Dimplex Americas. Please use our convenient online registration page to record your model and serial numbers for future reference at

www.dimplex.com/register

Model Number
and Serial
Number

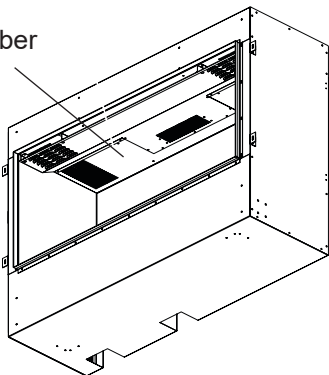

**Please carefully
read and save these
instructions.**

⚠ CAUTION: Read all instructions and warnings carefully before starting installation. Failure to follow these instructions may result in a possible electric shock, fire hazard and will void the warranty.

STOP NO NEED TO RETURN TO THE STORE

Questions with operation or assembly? Require Parts Information?
Product Under Manufacturer's Warranty?

Contact us at:  **www.dimplex.com/customer_support**
For Troubleshooting and Technical Support

OR  **Toll-Free 1-888-346-7539**

Monday to Friday 8:00 a.m. to 4:30 p.m. EST

In order to better serve you, please have your model and serial number ready or register your product online before calling (See above)

IMPORTANT INSTRUCTIONS

When using electrical appliances, basic precautions should always be followed to reduce the risk of fire, electric shock, and injury to persons, including the following:

- ① Read all instructions before using the heater.
- ② The heater is hot when in use. To avoid burns, do not let bare skin touch hot surfaces. The surface around the heater outlet becomes hot during heater operation.
-  **DANGER:** High temperatures may be generated under certain abnormal conditions. Do not partially or fully cover or obstruct the front of this heater.
- ③ Extreme caution is necessary when any heater is used by or near children or invalids and whenever the unit is left operating and unattended.
- ④ Always disconnect the heater when not in use.
- ⑤ Do not operate any heater after it malfunctions. Disconnect power at the service panel and have the heater inspected by a reputable electrician before reusing.
- ⑥ Do not operate any unit with a damaged cord or if the heater has malfunctioned, or if the heater has been dropped or damaged in any manner, contact Glen Dimplex Americas Technical Service at 1-888-346-7539.
- ⑦ Do not use outdoors.
- ⑧ Never locate heater over a bathtub or other water container.
- ⑨ To disconnect the unit, turn the controls OFF, disconnect power at the service panel.
- ⑩ Do not insert or allow foreign objects to enter any ventilation or exhaust opening as this may cause an electric shock or fire, or damage to the heater.
- ⑪ To prevent a possible fire, do not block air intake or exhaust in any manner.
- ⑫ All electrical heaters have hot and arcing or sparking parts inside. Do not use in areas where gasoline, paint, or flammable liquids are used or stored.
- ⑬ Do not modify the heater. Use it only as described in this manual. Any other use not recommended

IMPORTANT INSTRUCTIONS

by the manufacturer may cause fire, electric shock or injury to persons.

⑭ Always use a certified electrician should new circuits or outlets be required.

⑮ Always use properly grounded, fused and polarized outlets.

⑯ Disconnect all power supply before performing any cleaning, maintenance or relocation of the unit.

⑰ When transporting or storing the unit, keep in a dry place, free from excessive vibration and store so as to avoid damage.

! NOTE: Changes or modifications not expressly approved by the party responsible for compliance could void user's authority to operate the equipment.

For Bathroom Use

If this unit is installed in a bathroom it must be protected by a GFI receptacle or circuit. If receptacle is used it must be readily accessible.

To prevent electrical shock this unit is an electrical appliance that is not watertight and must be installed as to prevent water from entering unit. This must be installed away from showers, tubs, etc. Never locate fireplace where it may fall into a bathtub or other water container.



CAUTION
RISK OF ELECTRIC SHOCK
DO NOT OPEN
NO USER-SERVICEABLE PARTS INSIDE



SAVE THESE INSTRUCTIONS

Installation

⚠ WARNING: ANY INSTALLATION AND SERVICE WORK SHOULD BE PERFORMED BY QUALIFIED AND AUTHORIZED PERSONNEL. ALL INSTALLATIONS MUST COMPLY WITH ALL LOCAL CODES AND BY-LAWS, AND INSPECTED AND APPROVED FOR OPERATION BY LOCAL GOVERNING AUTHORITY PRIOR TO USE.

⚠ WARNING: Construction and electrical wiring must comply with local building codes and other applicable regulations to reduce the risk of fire, electric shock and injury to persons.

Opti-myst Cassette

The Opti-myst Pro Box Heater works exclusively with the Opti-myst Cassette (CDFI1000-PRO). Controls for the heater are found on the cassette.

New Construction

When determining a location for the Opti-myst® Pro Box Heater, ensure that the unit will not be susceptible to drafts, vents, ceiling fans and other air currents. Similar to a candle, large movements of air will affect the unit's ability to create and maintain the flame effect.

Hardwire Installation

The Opti-myst Pro Box Heater is supplied in an assembled state and is designed to be permanently installed. The unit comes ready for hardwire installation.

⚠ WARNING: Do not attempt to wire your own new outlets or circuits. To reduce the risk of fire, electric shock or injury to persons, always use a licensed electrician.

! NOTE: Please read all instructions before installing.

1. For rough in framing, the opening should follow the recommended dimensions located in Figure 1.

! NOTE: Dimensions provided are minimum clearances and will vary depending on type of support framing and finishing options.

! NOTE: Framing should be constructed to support 160 lbs (73 kg)

⚠ WARNING: To reduce the risk of fire, do not store or use gasoline or other flammable vapours or liquids in the vicinity of the unit.

2. Allow at least 4 ft. (122 cm) of service cable for connecting

Installation

a power supply wire to the Opti-myst Cassette when installing before finishing wall.

! NOTE: A 15 amp, 120 volt alternating current (VAC) circuit is required. A dedicated circuit is preferred but not essential in all cases. A dedicated circuit will be required if, after installation, the circuit breaker trips or the fuse blows on a regular basis when the heater is operating. Additional appliances on the same circuit may exceed the current rating of the circuit breaker.

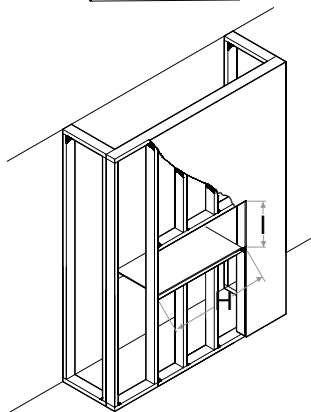
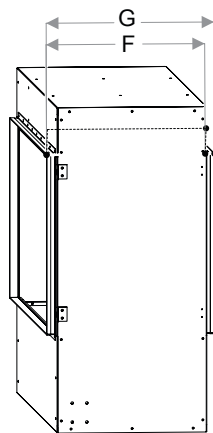
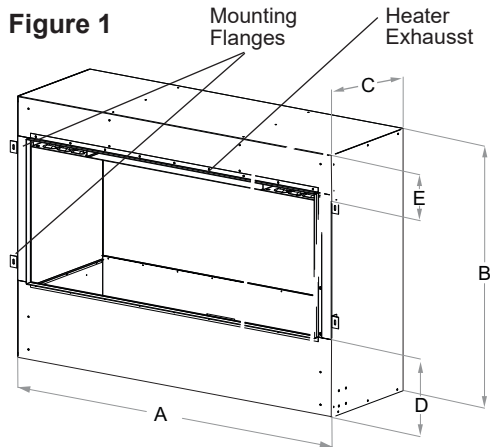

! NOTE: Use minimum 14 AWG supply cable with two insulated copper conductors (white and black) and one bare ground wire.

	A	B	C	D	E	F	G	H	I
CDFI-BX1000	44.9" (114 cm)	31.75" (80.5 cm)	14.7" (37.3 cm)	9.5" (24 cm)	4.8" (12.2 cm)	15.5" (39.3 cm)	16.2" (41.2 cm)	45.2" (115.2 cm)	32.3" (82 cm)

Installation

Do not use cable with aluminum conductors.

! NOTE: It is recommended that all drywall installation and finishing be completed after unit is fully installed.

3. The Opti-myst Pro Box Heater can be installed to be two sided or one sided. For one sided installations remove the 4 flanges on the back if there is not enough depth in the framing for them. Using the same screws, replace the back panel. See Figure 2. For two sided installations, remove flanges and back panel and using the same screws, replace the flanges.

! NOTE: The heater only exhausts from one direction. Note this

direction when installing in a 2 sided configuration"

- ! CAUTION:** When inserting the unit take care not to damage or pinch any of the power cables that are concealed in the wall.
4. Mount the Opti-myst Pro Box Heater to the framing with the mounting brackets using appropriate screws for the application (Figure 1).
5. Feed the wire through the opening on the back left of the Opti-myst Pro Box Heater. Remove the outer jacket and strip the individual conductors ½ in. (1.3 cm) from the end.
6. Do not remove cardboard backing from the Opti-myst Pro

Figure 2

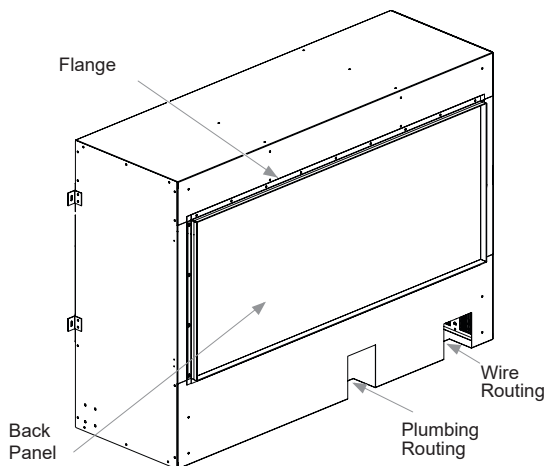

Installation

Box Heater until the Opti-myst Cassette is installed. This will help prevent scratches and damage to the sides of the Opti-myst Pro Box Heater.

7. Follow the installation instructions provided with the Opti-myst Cassette to install within the Opti-myst Pro Box Heater. Use the provided screws to fasten the cassette to the Opti-myst Pro Box Heater through the holes in the cassette (Figure 3).

8. In the back left corner of the Opti-myst Cassette (Figure 3), locate and remove the electrical cover plate by removing the two securing screws.

9. Install a cable connector (not included) suitable for mounting in a $\frac{7}{8}$ in. (22 mm) hole, to the cable plate and feed the supply cable through the connector. The cable plate can be removed by removing the two securing screws on either side, to allow for easier access.

⚠ CAUTION: Use two conductor, non-metallic sheath cable with ground wire (3 wires total) for the incoming power supply on the cassette. Use appropriate wire to meet local and national electrical codes for rated power.

10. Connect the black wires (live) from the Opti-myst Cassette and

Figure 3

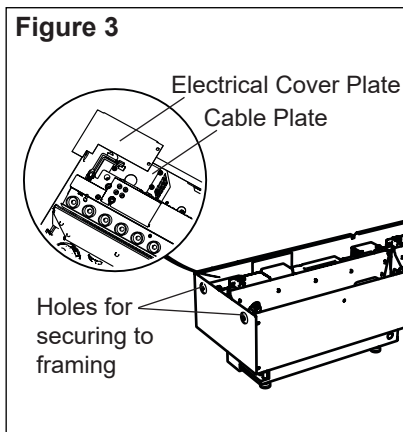

Opti-myst Pro Box Heater to the live from the power supply.

11. Connect the white wires (neutral) from the Opti-myst Cassette and Opti-myst Pro Box Heater to the neutral wire from the power supply.
12. Connect the green wires (ground) from the Opti-myst Cassette and Opti-myst Pro Box Heater to the ground wire from the power supply.
13. Place all connectors inside the Opti-myst Cassette and secure the cable clamp to unit, making sure that the cable clamp grips only the jacket of service cable.

⚠ CAUTION: Ensure the wire connectors are securely tightened, so no bare wires (live or neutral) are exposed.

Installation

14. Connect the 2 pin connector from the Opti-myst Cassette to the Opti-myst Pro Box Heater (Figure 4).
15. Finish surrounding wall. There are 3 different options for finishing the wall:
 - **Permanent** - install drywall right up to the flange that surrounds the opening.
 - **Semi Permanent** - finish around edge using flashing material (not included)
 - **Flexible** - create opening big enough to access mounting flanges and a false front that can be removed.

⚠ WARNING: Disconnect power before attempting any maintenance or cleaning to reduce the risk of fire, electric shock or damage to persons.

16. The media plate that came with the Opti-myst Cassette is not required and can be discarded. After completing installation, place the media tray that came with the Opti-myst Pro Box Heater in position over the Opti-myst Cassette. The tray can be used to hold a variety of media. Please note that the tray gets warm, so choose materials appropriately.

Figure 4

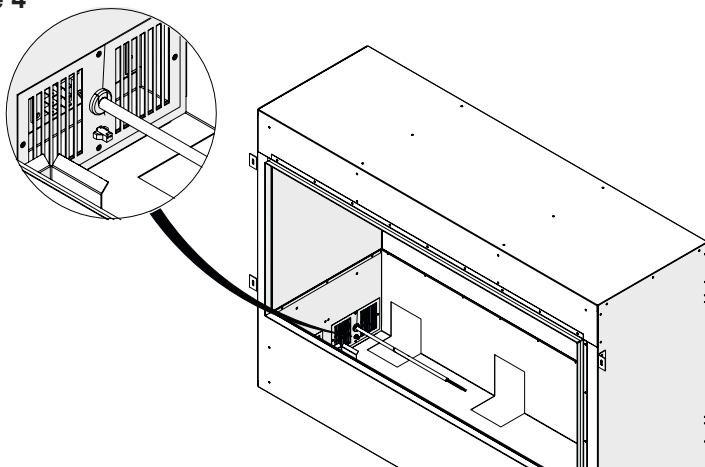

🔑 Operation

The heater can be controlled by remote, or the tethered controller through the Opti-myst Cassette. Please refer to cassette User's Guide for details.

! NOTE: The Opti-myst Pro Box Heater cannot be operated independently from the Opti-myst Cassette.

Resetting the Temperature Cutoff Switch

Should the heater overheat, an automatic switch will turn the heater off and it will not come back on without being reset. The

temperature cutoff switch can be reset by disconnecting power to the unit, waiting 5 minutes and reconnecting power to the unit.

⚠ CAUTION: If you need to continuously reset the heater, disconnect power to the unit and call Glen Dimplex Americas at 1-888-346-7539 for technical support. Please have your model and serial number ready when calling.

WIRING DIAGRAM

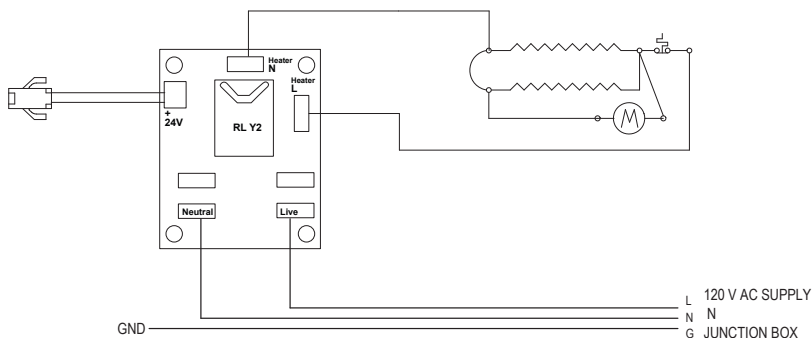



Maintenance

Opti-myst Pro Box Heater Surface Cleaning

To remove fingerprints or other marks, the exterior finish can be cleaned with a damp cloth with a mild detergent. The surface should be completely dried with a lint free cloth to prevent water spots.

! NOTE: The heater should not be operated with an accumulation of dust or dirt on or in the unit, as this can cause a build up of heat and eventual damage. For this reason the heater must be inspected regularly, depending upon conditions and at least at yearly intervals.

Servicing

Except for installation and cleaning described in this manual, an authorized service representative should perform any other servicing.



Warranty

2 YEAR LIMITED WARRANTY

Products to which this limited warranty applies

This limited warranty applies to your newly purchased Dimplex heater. This limited warranty applies only to purchases made in any province of Canada except for Yukon Territory, Nunavut, or Northwest Territories or in any of the 50 States of the USA (and the District of Columbia) except for Hawaii and Alaska. This limited warranty applies to the original purchaser of the Product only and is not transferable.

Products excluded from this limited warranty

Products purchased in Yukon Territory, Nunavut, Northwest Territories, Hawaii, or Alaska are not covered by this limited warranty. Products purchased in these States, provinces, or territories are sold AS IS without warranty or condition of any kind (including, without limitation, any implied warranties or conditions of merchantability or fitness for a particular purpose) and the entire risk of as to the quality and performance of the products is with the purchaser, and in the event of a defect the purchaser assumes the entire cost of all necessary servicing or repair.

What this limited warranty covers and for how long

Products covered by this limited warranty have been tested and inspected prior to shipment and, subject to the provisions of this warranty, Glen Dimplex Americas Ltd. (herein called Glen Dimplex Americas) warrants such products to be free from defects in material and workmanship in respect of the heater components of the Product for a period of 24 months from the date of the first purchase of the Product.

This limited warranty period also applies to any implied warranties that may exist

under applicable law. Some jurisdictions do not allow limitations on how long an implied warranty lasts, so the above limitation may not apply to the purchaser.

What this limited warranty does not cover

This limited warranty does not apply to Products that have been repaired (except by Glen Dimplex Americas or its authorized service representatives) or otherwise altered. This limited warranty does further not apply to defects resulting from misuse, abuse, accident, neglect, incorrect installation, improper maintenance or handling, operation with an incorrect power source, fire or other circumstance outside of Glen Dimplex Americas' control including, without limitation, an Act of God.

What you must do to get service under this limited warranty

Defects must be brought to the attention of Glen Dimplex Americas Technical Service by contacting 1-888-346-7539. Please have proof of purchase, catalogue/model and serial numbers available when calling. Limited warranty service requires a proof of purchase of the Product.

What Glen Dimplex Americas will do in the event of a defect

In the event the Product or part covered by this limited warranty is proven to be defective in material or workmanship during, in the One Year Warranty period, as applicable, you have the following rights:

- Glen Dimplex Americas will in its sole discretion either repair or replace such defective Product or part without charge. If Glen Dimplex Americas is unable to repair or replace the Product or part, or if repair or replacement is not commercially practicable or cannot be timely made, Glen Dimplex Americas



Warranty

may, in lieu of repair or replacement, choose to refund the purchase price for the Product or part.

- Limited warranty service will be performed solely by dealers or service agents of Glen Dimplex Americas authorized to provide limited warranty services.
- For products other than surrounds (mantels) and trims, this 2 year limited warranty entitles the purchaser to on-site or in-home warranty services. Accordingly, Glen Dimplex Americas will be responsible for all labour and transportation associated with repairing or replacing the product or part except as follows: (i) charges which may be levied for travel costs incurred to travel to the purchaser's site where the product is located if the purchaser's site is beyond 30 miles (48 km) from the closest service depot of Glen Dimplex Americas dealer or service agent; and (ii) the purchaser is solely responsible for providing clear access to all serviceable parts of the product.
- Glen Dimplex Americas will not be responsible for, and the limited warranty services shall not include, any expense incurred for installation or removal of the Product or part (or any replacement Product or part) or any labour or transportation costs. Such costs shall be the purchaser's responsibility.

What Glen Dimplex Americas and its dealers and service agents are also not responsible for:

IN NO EVENT WILL GLEN DIMPLEX AMERICAS, OR ITS DIRECTORS, OFFICERS, OR AGENTS, BE LIABLE TO THE PURCHASER OR ANY THIRD PARTY, WHETHER IN CONTRACT, IN TORT, OR ON ANY OTHER BASIS, FOR ANY INDIRECT, SPECIAL, PUNITIVE,

EXEMPLARY, CONSEQUENTIAL, OR INCIDENTAL LOSS, COST, OR DAMAGE ARISING OUT OF OR IN CONNECTION WITH THE SALE, MAINTENANCE, USE, OR INABILITY TO USE THE PRODUCT, EVEN IF GLEN DIMPLEX AMERICAS OR ITS DIRECTORS, OFFICERS, OR AGENTS HAVE BEEN ADVISED OF THE POSSIBILITY OF SUCH LOSSES, COSTS OR DAMAGES, OR IF SUCH LOSSES, COSTS, OR DAMAGES ARE FORESEEABLE. IN NO EVENT WILL GLEN DIMPLEX AMERICAS, OR ITS OFFICERS, DIRECTORS, OR AGENTS BE LIABLE FOR ANY DIRECT LOSSES, COSTS, OR DAMAGES THAT EXCEED THE PURCHASE PRICE OF THE PRODUCT.

SOME JURISDICTIONS DO NOT ALLOW THE EXCLUSION OR LIMITATION OF INCIDENTAL OR CONSEQUENTIAL DAMAGES, SO THE ABOVE LIMITATION OR EXCLUSION MAY NOT APPLY TO THE PURCHASER.

How State and Provincial law apply

This limited warranty gives you specific legal rights, and you may also have other rights which vary from jurisdiction to jurisdiction. The provisions of the United Nations Convention on Contracts for the Sale of Goods shall not apply to this limited warranty or the sale of Product covered by this limited warranty.



Technical Support

Technical and troubleshooting support, as well as a list of replacement parts can be found on www.dimplex.com/customer_support.

1-888-346-7539 | www.dimplex.com

In keeping with our policy of continuous product improvement, we reserve the right to make changes without notice.

GlenDimplex
AMERICAS
Enhancing the moments that matter in life

The logo for GlenDimplex Americas, featuring a stylized knot or interlocking circular design to the right of the brand name.

© 2019 Glen Dimplex Americas