





HEKMAN[®]

A HOWARD MILLER COMPANY

ASSEMBLY INSTRUCTIONS FOR 25364 QUEEN UPHOLSTERED FOOTBOARD

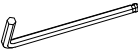
HARDWARE LIST

NO.	ITEM	DESCRIPTION	QTY	NO.	ITEM	DESCRIPTION	QTY
1		BOLT Ø1/4" x 1-1/2"	2	2		LOCK WASHER	10
3		FLAT WASHER	10	4		ALLEN WRENCH	1
5		BOLT Ø1/4" x 1"	8				

STEP 2

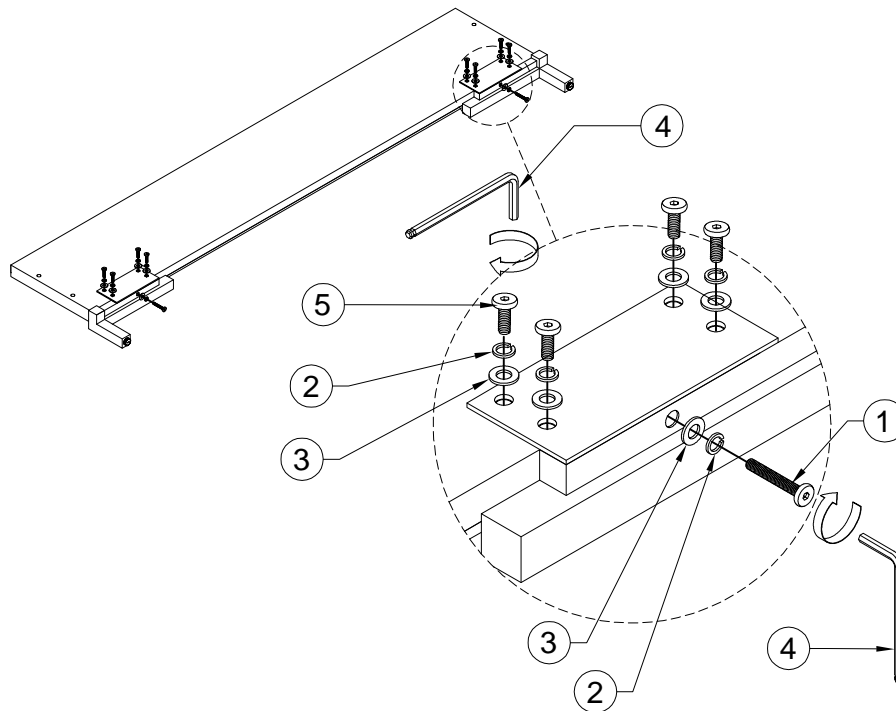

TO ASSEMBLY:

STEP 1: Lay the footboard face down on a piece of cloth or carpet to prevent the finish from scratching.

STEP 2: Attach the legs to the footboard. Insert the flat washer (3), lock washer (2), with long bolt (1) & short bolt (5) to the footboard, tighten with allen wrench (4).

