

Product Specifications

4.2-Quart Round Container with Snap-on Cover

Multiple Uses

Dairy Products
Frozen Desserts

Product Codes

Container: **D423**
Description: 4.2 quart / 4.0 L round can

Cover: **D4D0**

Description: Round snap-on cover

Features

Gauge: 30 mil.
Nominal capacity: 4.2 Qt / 4.0 L
Stack performance: N/A *
Tare weights: Body: .22 lbs. / .10 kgs
Cover: .11 lbs. / .05 kgs

Specifications with Cover

Dimensions: 8-1/2" D X 5-1/2" H
Maximum capacity: 4.4 Qt / 4.2 L
Tare weight: .33 lbs. / .15 kgs.

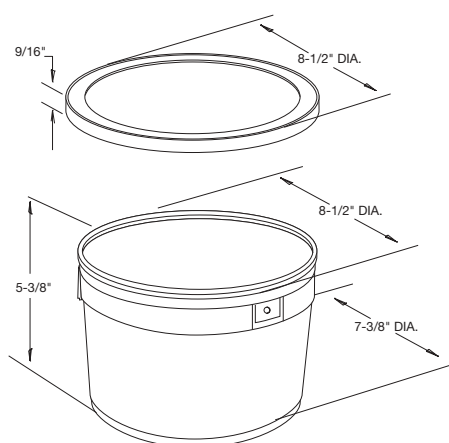

Colors

Standard: White and Natural
Custom: Available at manufacturer's discretion

Decorating Options

Four or six* color offset printing
Print area: 23-3/4" W X 3-1/4" H
Cover: 6-7/8" Diameter

Note: *Where available

Shipping Data

Qty. per pallet: 1200
Gross Weight (lbs./kgs.):* 264/120
Den. (lbs./c.f./kgs./m3): 6.4/102.4
Length (in./cm.): 50/127
Width (in./cm.): 37.9/96.3
Height (in./cm.): 37.7/95.8
Estimated truckload quantity of 43,200 bodies and covers**

Bodies

Covers

Filled Containers

5,000 (25 boxes of 200)
180 (20 per layer/9 layers high)

Pallet height: 51"

Notes: *Weight does not include pallet/packaging
**Truckload quantity based on 53' trailer

Materials

FDA approved materials
Resin: Body: High-Density Polyethylene (HDPE)
Cover: Linear Low Density Polyethylene (LLDPE)
MSDS Sheets available upon request

Optional Carrying Handles

DISCLAIMER
THIS INFORMATION IS PROVIDED AS A GENERAL GUIDE, INCLUDING DIMENSIONS. IT IS THE CUSTOMER'S RESPONSIBILITIES TO SELECT THE PROPER CONTAINER FOR PRODUCT AND APPLICATION COMPATIBILITY.

DISTRIBUTED BY:



REF NO.:

DWG30599

DESCRIPTION:

4.2 Quart Open Head Nestable Pail