

**PRODUCT SPECIFICATIONS**

Dayton® 2" Stainless Steel Drain with Removable Basket Strainer and Rubber Stopper. Overall dimensions are 2-7/8" x 2-7/8" x 1-1/2". Made of Stainless Steel.

<b>Material:</b>	Stainless Steel
<b>Finish:</b>	Polished Stainless Steel (S)
<b>Dimensions:</b>	2-7/8" x 2-7/8" x 1-1/2"
<b>Shipping Weight:</b>	1 lbs.

- **BASKET STRAINER AND STOPPER:** Strainer catches food and waste from going down the drain. Use stopper to fill sink with water for washing and soaking



A Century of Tradition and Quality.  
For more than 100 years, Elkay has been making innovative products and providing exceptional customer care. We take pride in offering plumbing products that make life easier, inspire change and leave the world a better place.

**Product Compliance:** ASME A112.18.2/CSA B125.2

[Clean and Care Manual \(PDF\)](#)  
[Installation Instructions \(PDF\) - 100005235](#)  
[Warranty \(PDF\)](#)

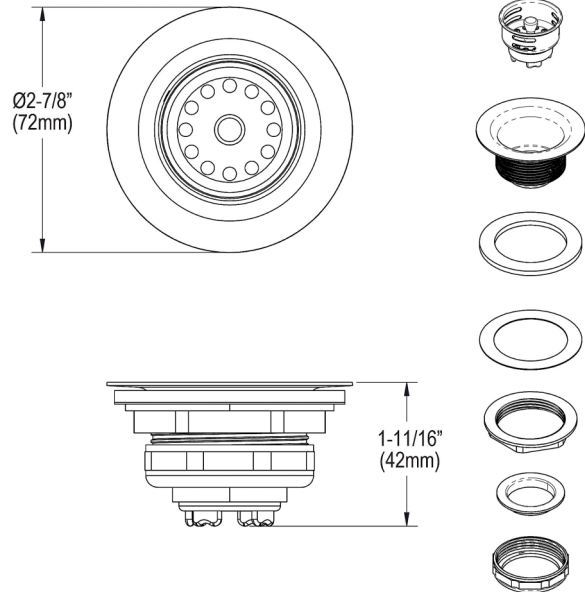

PART: \_\_\_\_\_ QTY: \_\_\_\_\_

PROJECT: \_\_\_\_\_

CONTACT: \_\_\_\_\_

DATE: \_\_\_\_\_

NOTES: \_\_\_\_\_

APPROVAL: \_\_\_\_\_

*In keeping with our policy of continuing product improvement, Elkay reserves the right to change product specifications without notice. Please visit [elkay.com](http://elkay.com) for the most current version of Elkay product specification sheets. This specification describes an Elkay product with design, quality, and functional benefits to the user. When making a comparison of other producers' offerings, be certain these features are not overlooked.*