











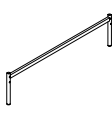
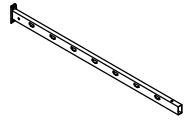
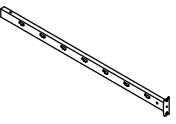
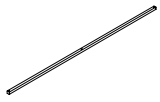
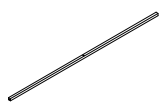

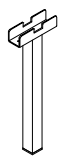

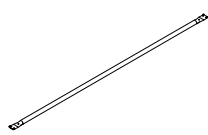
ASSEMBLY INSTRUCTION

METAL FULL BED

A 1PC LSF Headboard Post	B 1PC RSF Headboard Post	C 1PC Footboard	D 2PCS Front Rail Section
			
E 1PC Rear Rail Section	F 1PC Center Support Bar	G 1PC Front / Rear Support Bar	H 2PCS Center Rail
			
I 2PCS Rail Support Leg	J 1PC Center Support Leg	K 2PCS Front / Rear Support Leg	L 2PCS Slat
			
M 2PCS Slat Connector	N 1PC Headboard	O 2PCS Bolt 1/4" x 17.5mm	P 14PCS Bolt 5/16" x 19mm
			
Q 28PCS Bolt 5/16" x 55mm	R 6PCS Bolt 1/4" x 35mm	S 5PCS Bolt 5/16" x 48mm	T 2PCS Bolt 5/16" x 34mm
			
2PCS	6PCS	5PCS	2PCS

U L-Allen Key
4mm



1PC

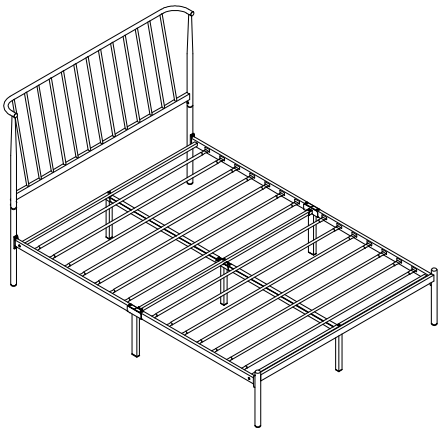

These pages list all the contents included in the box. Please take the time to identify the hardware as well as the individual components to this product. As you unpack and prepare for assembly, place the contents on a carpeted or padded area to protect them from damage.

1

Remove the plastic plugs from Headboard (N).

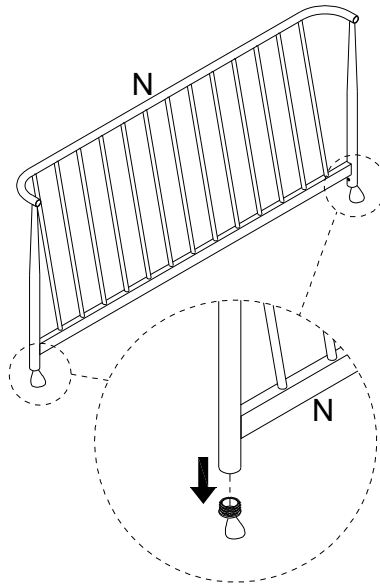

2

Attach LSF & RSF Headboard Post (A & B) to Headboard (N) using Bolt (O) with L-Allen Key (U).

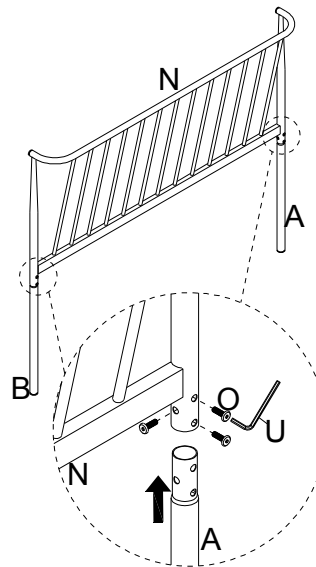

3

Attach Rail Support Leg (I) to Front & Rear Rail Section (D & E) using Bolt (S) with L-Allen Key (U).

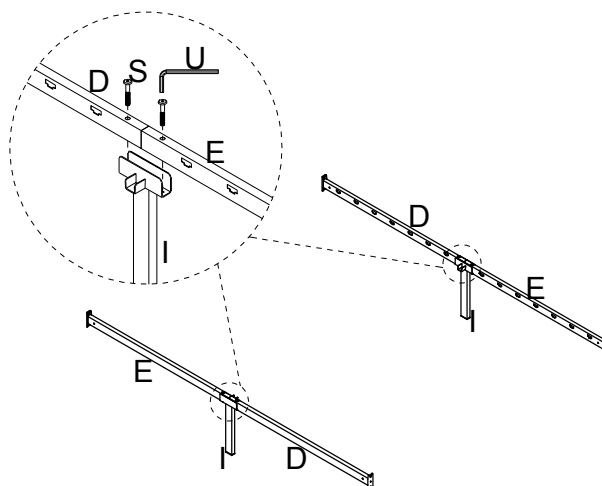

4

Attach Front & Rear Rail Section (D & E) to LSF & RSF Headboard Post (A & B) and Footboard (C) using Bolt (P) with L-Allen Key (U).

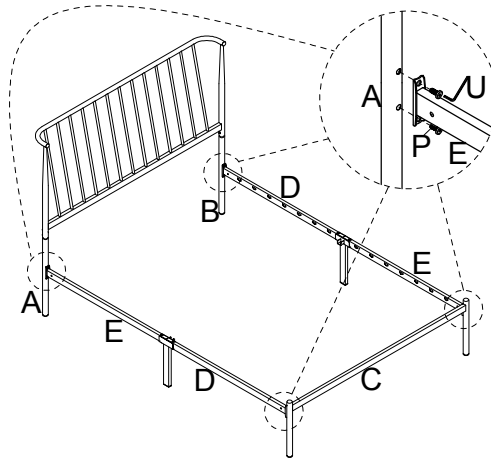
**5**

Attach Front / Rear Support Bar (G) to Front & Rear Rail Section (D & E) using Bolt (R) with L-Allen Key (U). Then attach Center Support Bar (F) to Rail Support Leg (I) using Bolt (R) with L-Allen Key (U).

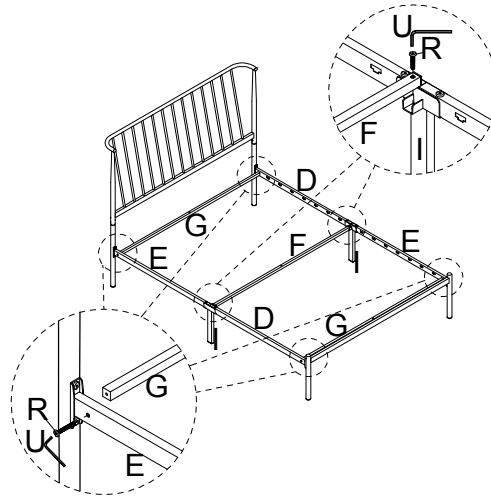
**6**

Attach Center Rail (H) and Front / Rear Support Leg (K) to Front / Rear Support Bar (G) using Bolt (Q) with L-Allen Key (U). Then attach Center Support Leg (J) to Center Rail (H) and Center Support Bar (F) using Bolt (T & S) with L-Allen Key (U).

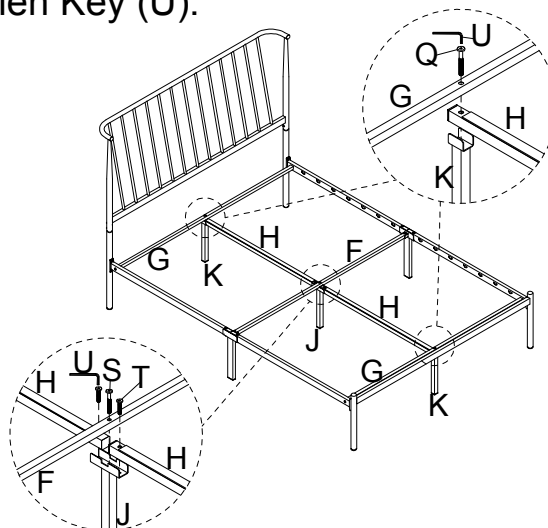

7

Insert Slat (L) into Front & Rear Rail Section (D & E) as shown. Then lock Slat Connector (M) to fix Slat (L).

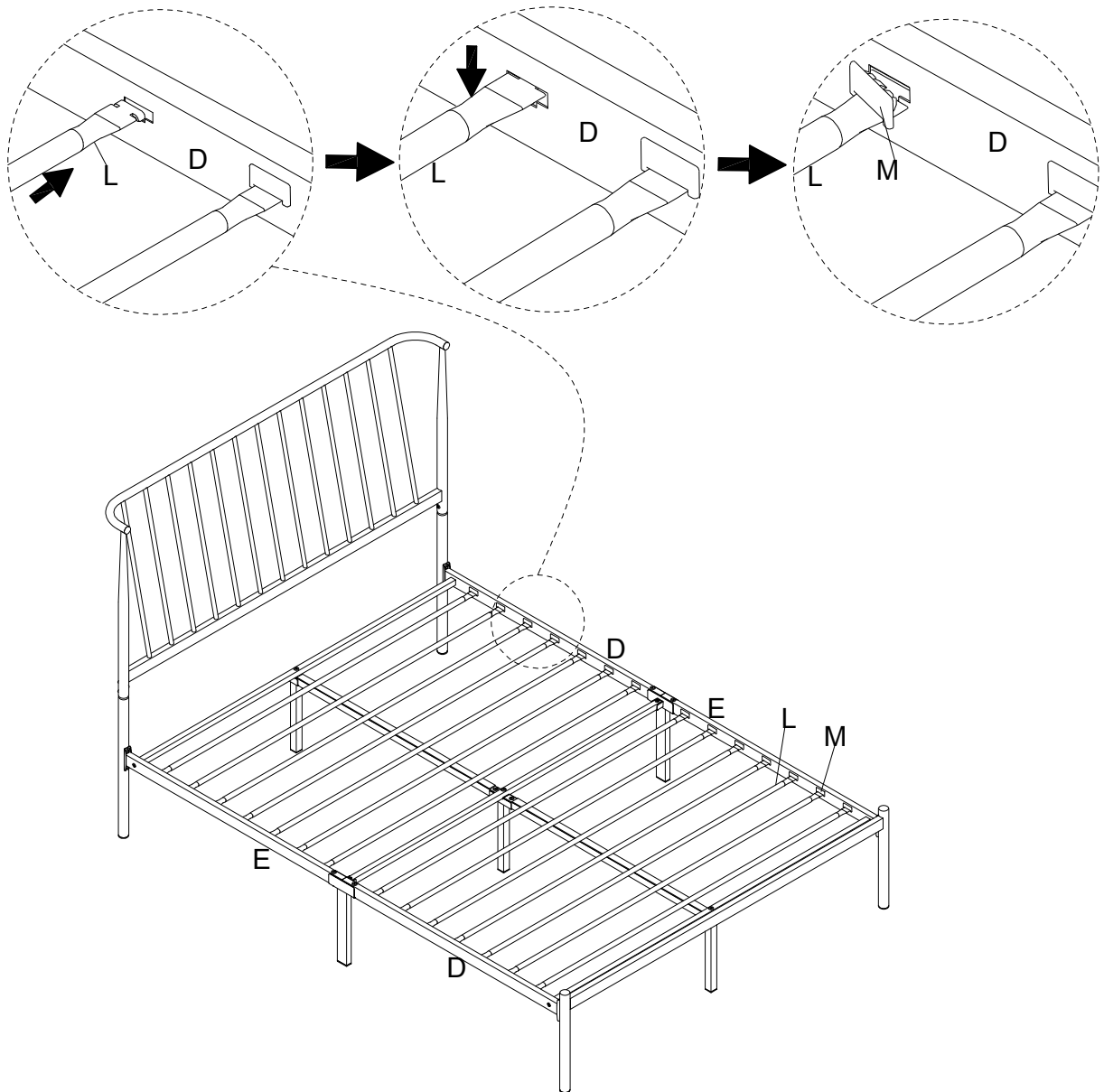

Cleaning & Care

Treat surfaces with care. Surfaces are resistant to scratches but are not scratch resistant. Clean surfaces with a dry or damp soft cloth. Do not use abrasive cleaners. Hardware may loosen over time. Periodically check that all connections are tight.