



BEST CHOICE
PRODUCTS



INSTRUCTION MANUAL

42" Round Dining Table with
Extension Leaf and Storage

! NOTICE | Please retain these instructions for future reference.

- Please do not exceed the weight limitations of this item.
- Do not stand on or use any part of this item as a step ladder.
- Firmly secure all bolts, screws, or knobs before use.
- Reconfirm that all bolts, screws, or knobs are secure every 90 days.
- Fasten screws loosely during initial assembly. Do not firmly tighten the screws until the item is completely assembled.
- Do not use or store this item in the proximity of open flame or flammable/combustible chemicals.
- Be aware that some parts are heavy and have sharp edges.
- Assemble this item on a flat, level, and stable surface for an ideal construction.
- This product is intended for indoor use only.
- If any parts are missing, broken, damaged, or worn, stop using this product until repairs are made and/or factory replacement parts are installed.
- Do not use this item in a way inconsistent with the manufacturer’s instructions as this could void the product warranty.
- This product is intended for residential use only.

TOOLS REQUIRED



PHILLIPS
SCREWDRIVER



M4 ALLEN WRENCH
(PROVIDED)



POWER DRILL
(RECOMMENDED)



300 LBS
CAPACITY



2 PERSON
ASSEMBLY



UP TO 30 MIN.
ASSEMBLY

HARDWARE

1 M6 x 50mm
BOLT



8 PCS

2 M6 SPRING
WASHER



8 PCS

3 M8 x 30mm
DOWEL



8 PCS

4 M4 x 32mm
SCREW



19 PCS

5 FOOT PAD



4 PCS

PARTS

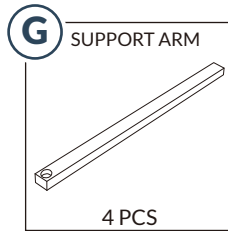
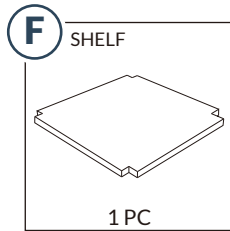
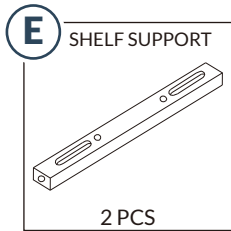
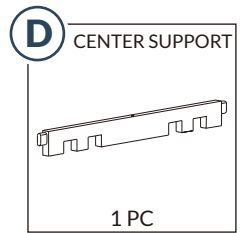
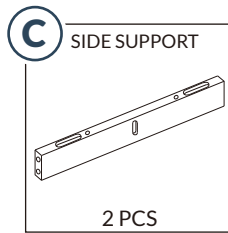
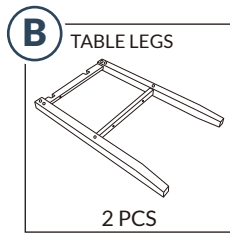
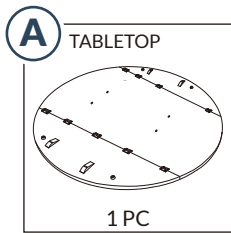

PRODUCT ASSEMBLY

- 1 | Insert four **part 3** dowels into two **part C** side supports, two dowels per frame.

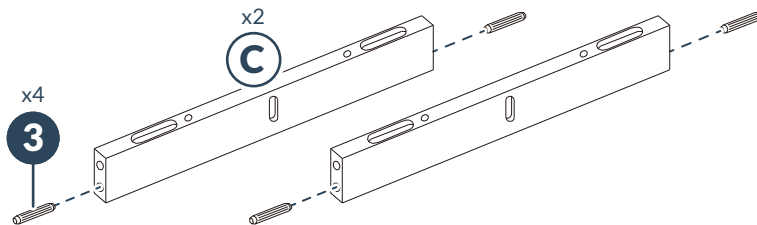

- 2 | Insert the side supports into the **part D** frame support.

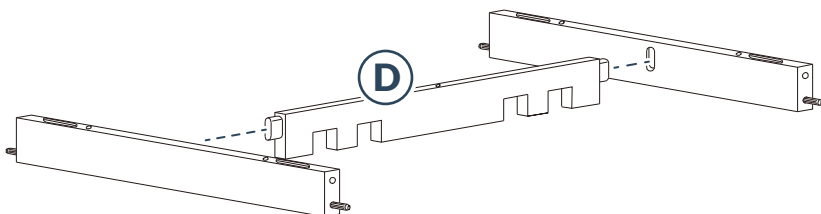

3 | Attach the support assembly and two **part E shelf supports** into their respective receivers on one **part B front legs**, secure with four **part 1 bolts** and four **part 2 spring washers**, one bolt and one washer per support.

NOTE: Tighten the screw further until semicircular wood area to be flat

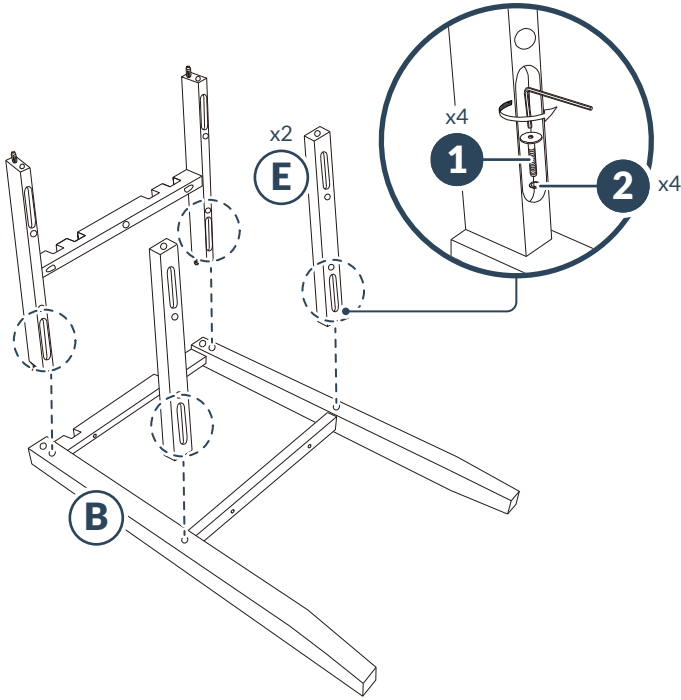

ANGLE OF THE SCREWS

Some screws go in at an angle by design. This keeps the joints hidden for a clean finish.

4 | Slide the **part F shelf** onto the **part E shelf supports**.

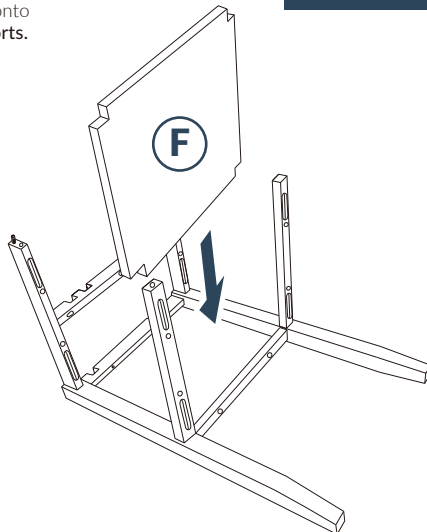

5 | Attach one **part B front legs** to the support assembly, secure with four **part 1 bolts** and four **part 2 spring washers**, one bolt and one washer per support.

NOTE: Tighten the screw further until semicircular wood area to be flat

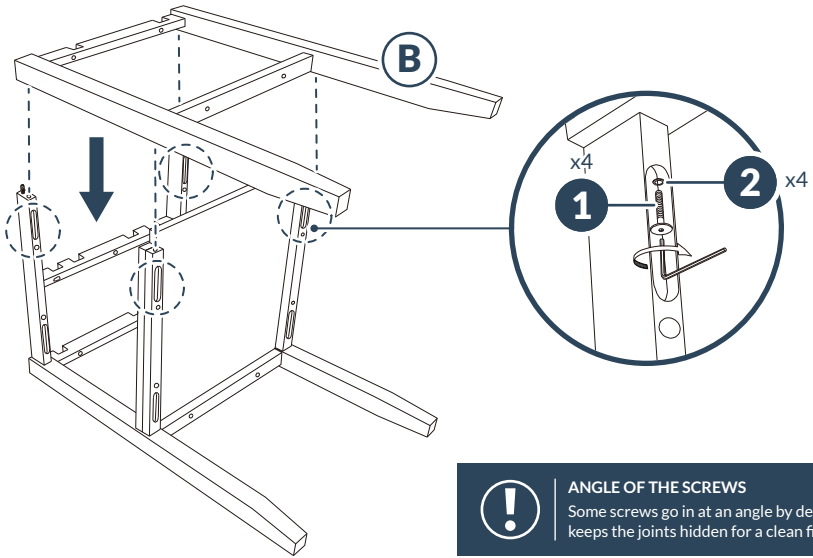

ANGLE OF THE SCREWS

Some screws go in at an angle by design. This keeps the joints hidden for a clean finish.

6 | Secure the **part F shelf** with eight **part 4 screws**.

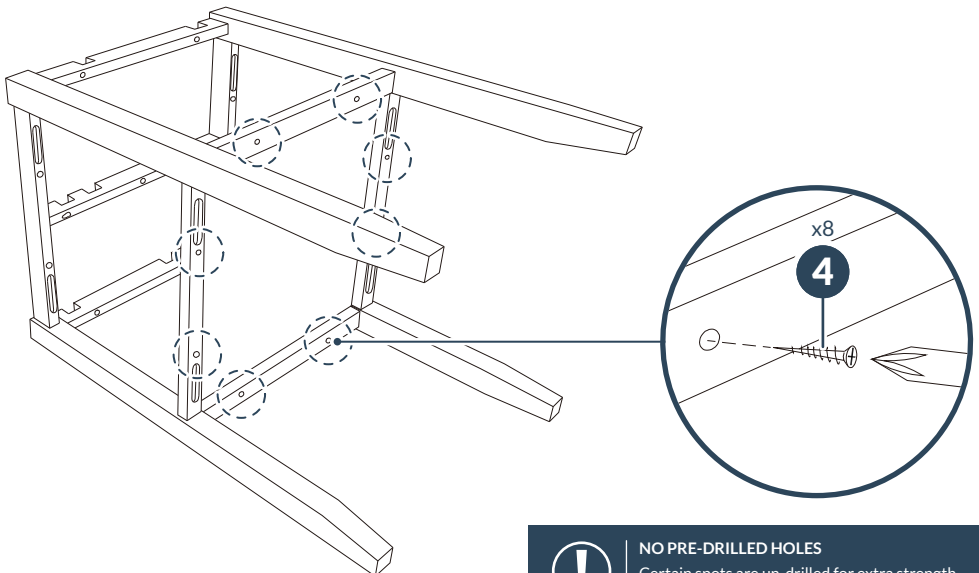

NO PRE-DRILLED HOLES

Certain spots are un-drilled for extra strength. This makes the table sturdier and longer-lasting.

7 | Insert four **part 3** dowels into the table legs assembly.

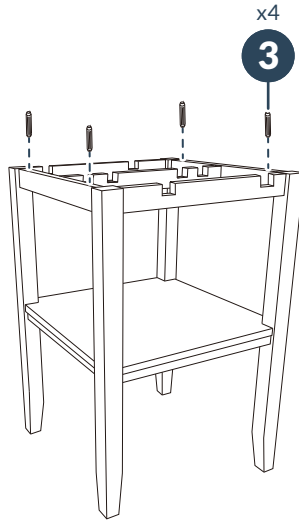

8 | Place the **part A** tabletop face down on a flat, covered surface to prevent scratches. Position the four **part G** support arms onto the tabletop as shown. Turn the table legs assembly upside down and press the dowels into the tabletop. Ensure the opening of the table legs assembly aligns with the support arms.

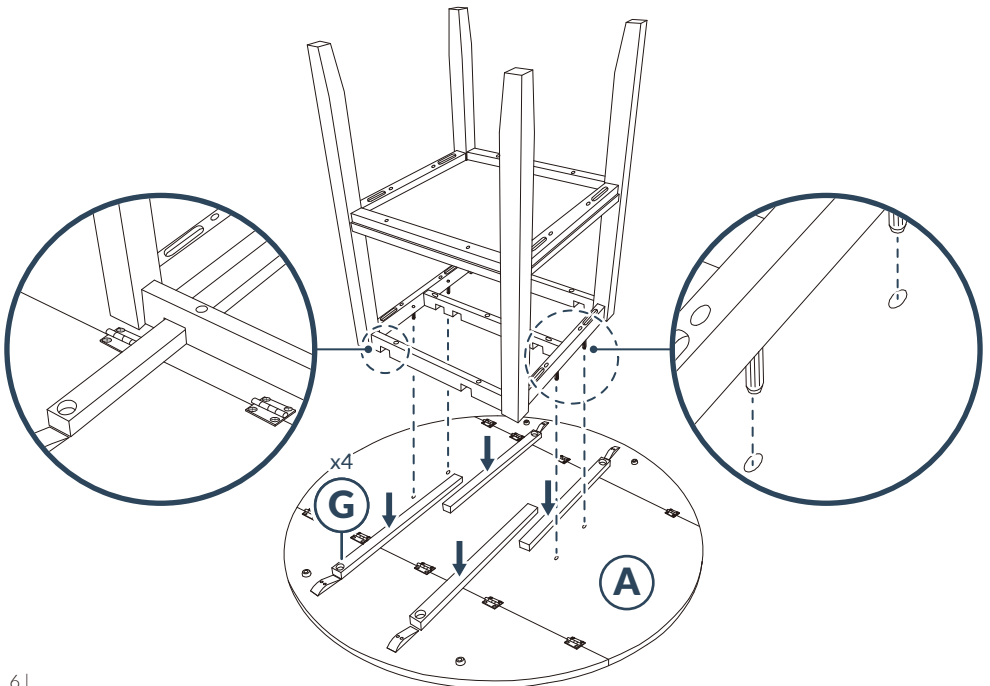

- 9** | Apply one **part 5 foot pad** onto each legs, four foot pads total.
 Secure the two **part B table legs** and two **part C side support** with eight **part 4 screws**.
 Secure the **part D center support** with three **part 4 screws**.

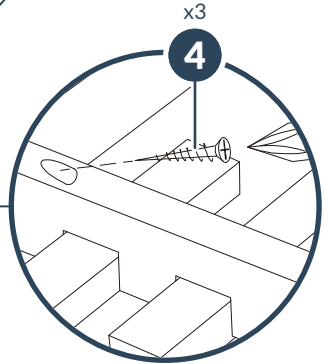
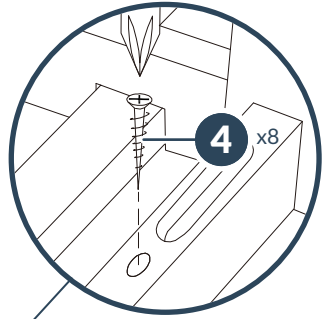
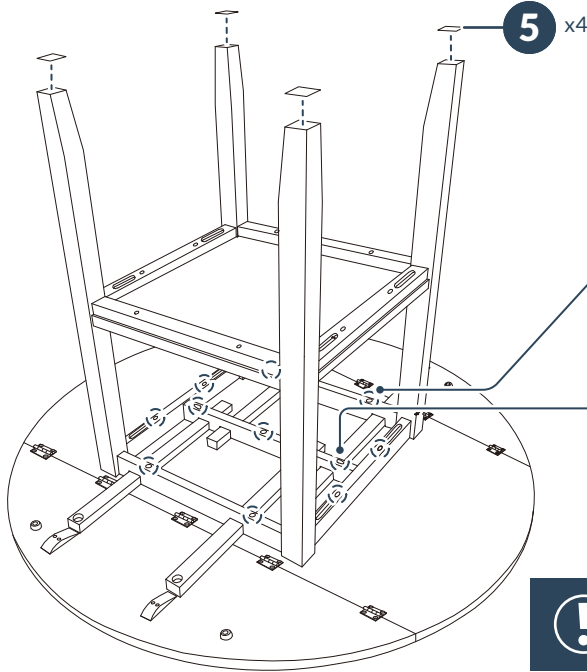

NO PRE-DRILLED HOLES
 Certain spots are un-drilled for extra strength.
 This makes the table sturdier and longer-lasting.

- 10** | **Flipping the Table**
 Lift with **two people** and flip slowly from the sides to keep it steady and protect your floor.

Collapsing the Leaf

Push the **part G support arms** back under the table and gently lower the leaf. Make sure it's fully down and secure before moving or using the table.

Extending the Leaf

Lift the leaf until it's level with the tabletop.
 Pull out the **part G support arms** underneath and lock it in place before adding weight.

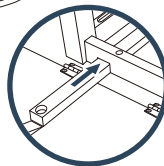



HELP CENTER

Question about your product? We're here to help. Visit us at:

bestchoiceproducts.com/pages/help



Chat Support



Product Inquiry



Orders FAQ



Product Assembly



Returns & Refunds

PRODUCT WARRANTY INFORMATION

All items can be returned for any reason within 60 days of the receipt and will receive a full refund as long as the item is returned in its original product packaging and all accessories from its original shipment are included. All returned items will receive a full refund back to the original payment method. All returned items will not be charged a re-stocking fee.

All returned items require an RA (Return Authorization) number, which can only be provided by a Best Choice Products Customer Service Representative when the return request is submitted. Items received without an RA may not be accepted or may increase your return processing time. Once an item has been received by Best Choice Products, refunds or replacements will be processed within 5 business days.

All returns must be shipped back to the Best Choice Products Return Center at the customer's expense. If the reason for return is a result of an error by Best Choice Products then Best Choice Products will provide a pre-paid shipping label via email. Boxes for return shipping will not be provided by Best Choice Products, and is the customer's responsibility to either use the original shipping boxes or purchase new boxes.

Pictures may be required for some returns to ensure an item is not damaged prior to its return. Items returned are not considered undamaged until they are received by Best Choice Products and verified as such. All damages to items are the customer's responsibility until the item has been received by and acknowledge by Best Choice Products as undamaged.

© Best Choice Products, Inc. All rights reserved. Distributed by Best Choice Products, Inc. Newport Beach, CA 92660

WARNING

Manufacturer and seller expressly disclaim any and all liability for personal injury, property damage or loss, whether direct, indirect, or incidental, resulting from the incorrect attachment, improper use, inadequate maintenance, unapproved modification, or neglect of this product.