

Item #: BKMCPLAT

Assembly Instructions

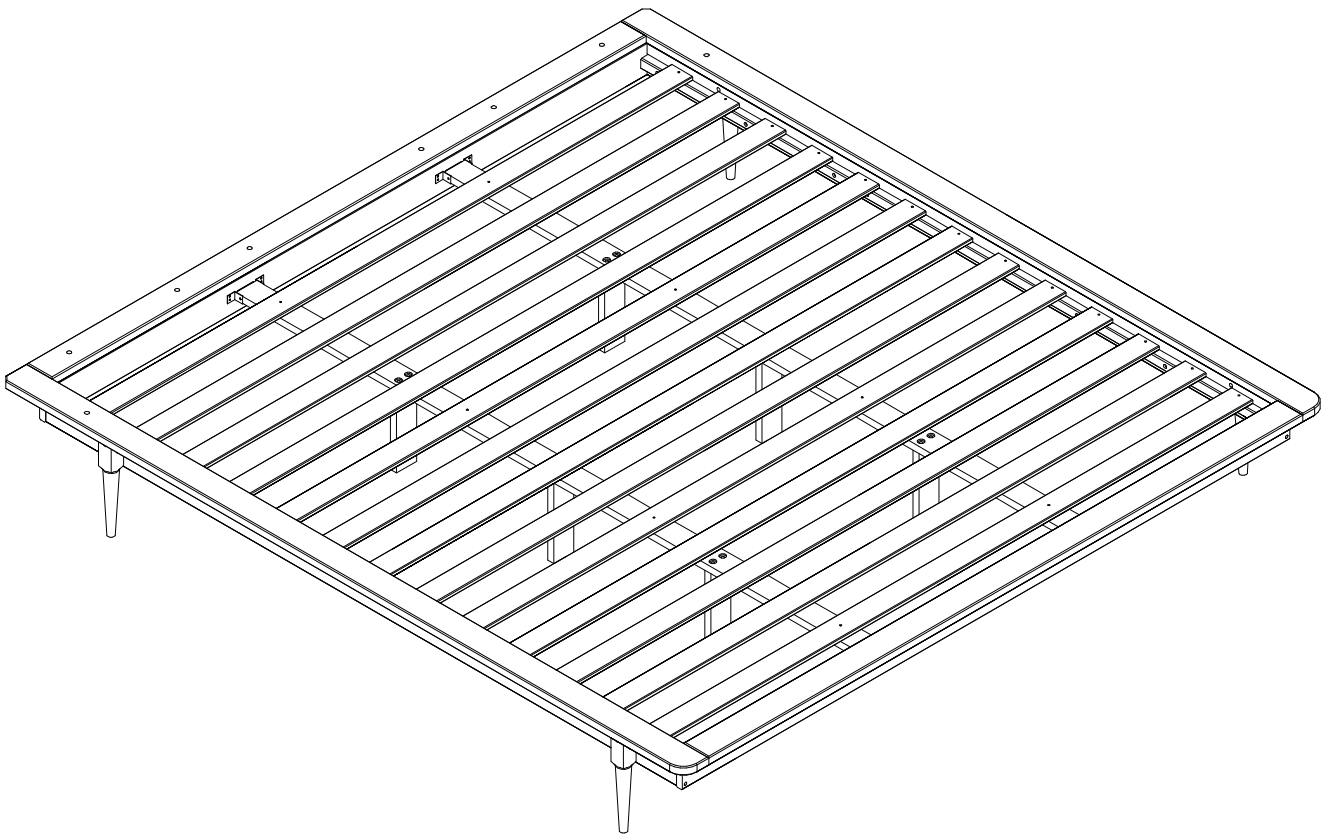

Please visit our website for the most current instructions, assembly tips, to report damage or request parts. www.walkeredison.com

Revised 08/2023 - V5

General Assembly Guidelines

- I. Ensure that all parts and hardware are available before beginning assembly.
- II. Follow each step carefully to ensure the proper assembly of this product.
- III. Two people are recommended for ease in the assembly of this product.
- IV. The three main types of hardware used to assemble this product are wood dowels, screws and bolts.
- V. A Phillips head screwdriver and hammer are required for the assembly of this product.

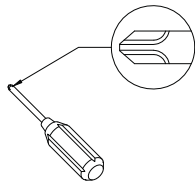

- VI. Power tools should not be used to assemble this product.

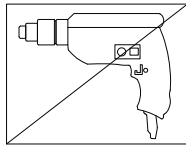



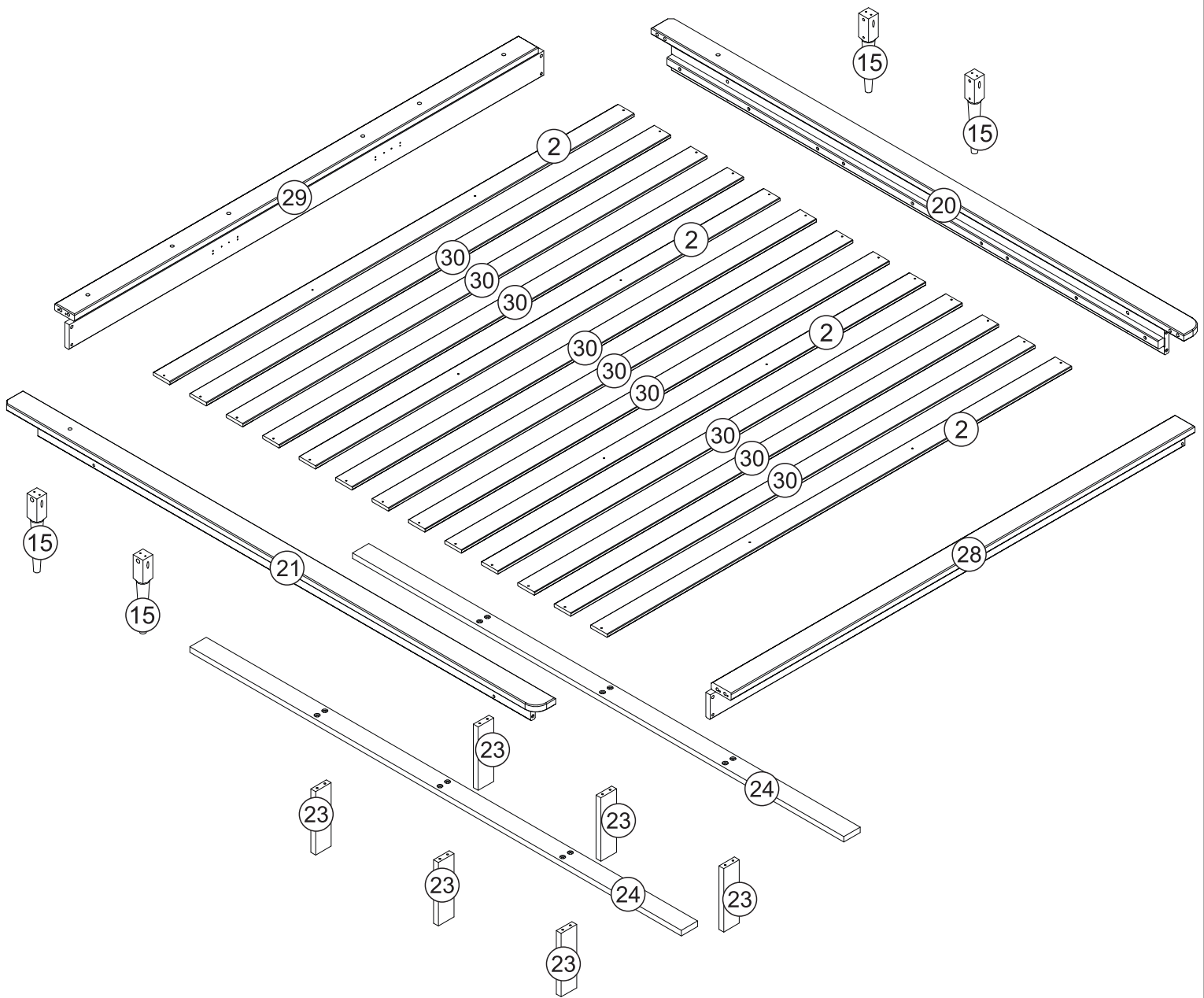



Parts List

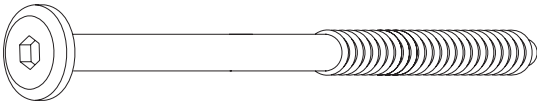

Part#	Description	Qty
2	Slats	04 pcs
15	Feet	04 pcs
20	Right side rail	01 pcs
21	Left side rail	01 pcs
23	Middle foot support	06 pcs

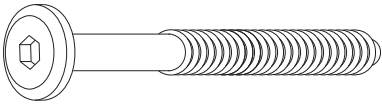
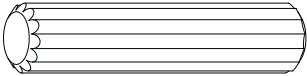
Part#	Description	Qty
24	Cross bar	02 pcs
28	Front rail	01 pcs
29	Back rail	01 pcs
30	Slat 2 Hole	09 pcs

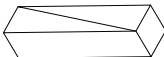
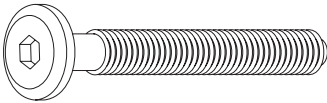
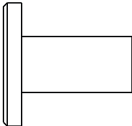
Hardware List

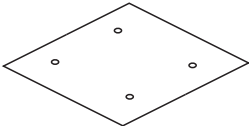
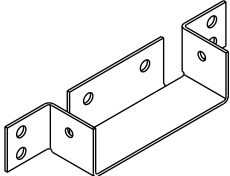
A		ø7,0"*70mm	Bolt	20 pcs
B		ø3.5*30mm	Screw	50 pcs
C		ø12mm	Hole Caps	08 pc
D		ø7,0"*50mm	Bolt	04 pcs
E		ø10"*40mm	Wood dowel	08 pc
J			Hex key	02 pc
L		82 mm	Spacer	02 pcs
M		ø1/4"*40mm	Bolt	04 pcs
N		ø1/4	Union Screw	04 pcs
P		ø4.0*16mm	Screw	40 pcs
Q			Metal Plate Connector	02 pcs
R			Center bar support	04 pcs

*The hardware quantities listed above are required for proper assembly.
Some extra hardware may also have been included.*

Step 1

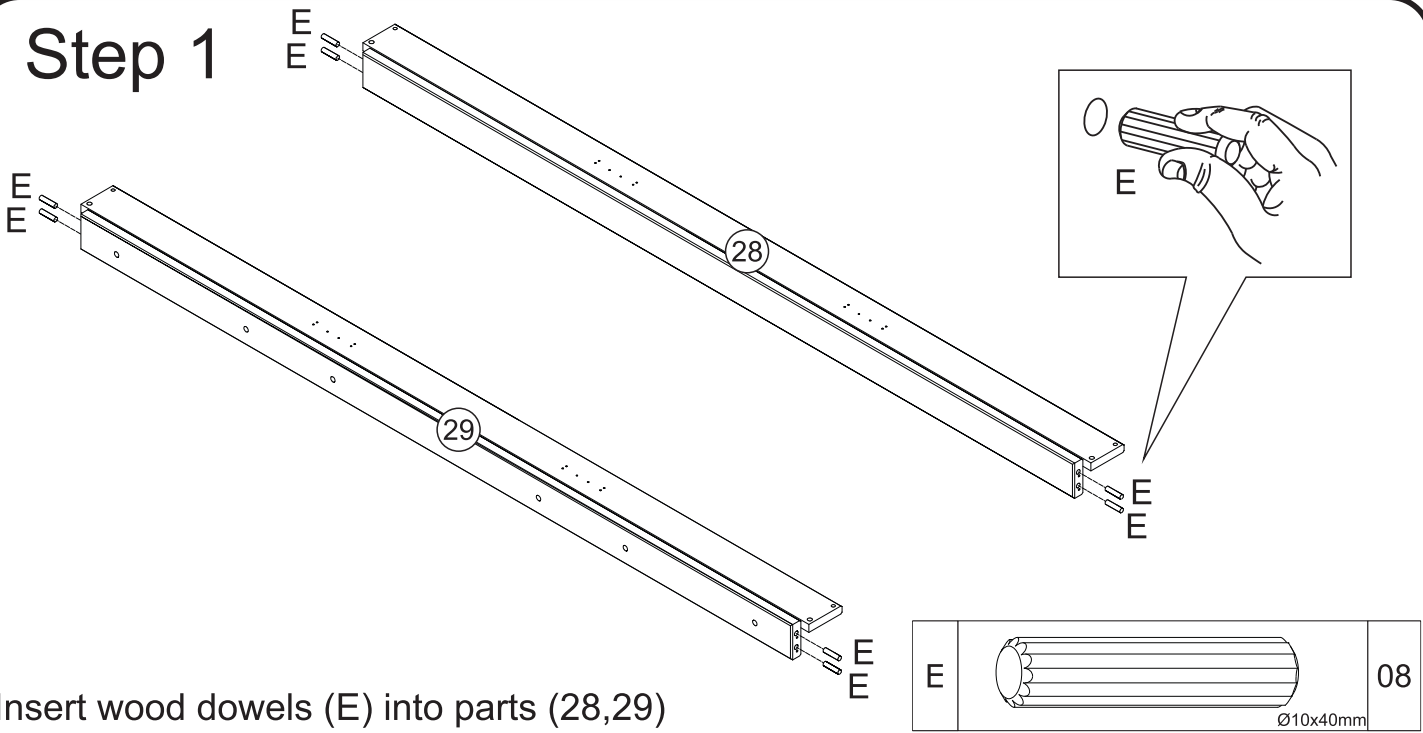

Insert wood dowels (E) into parts (28,29)

Step 2

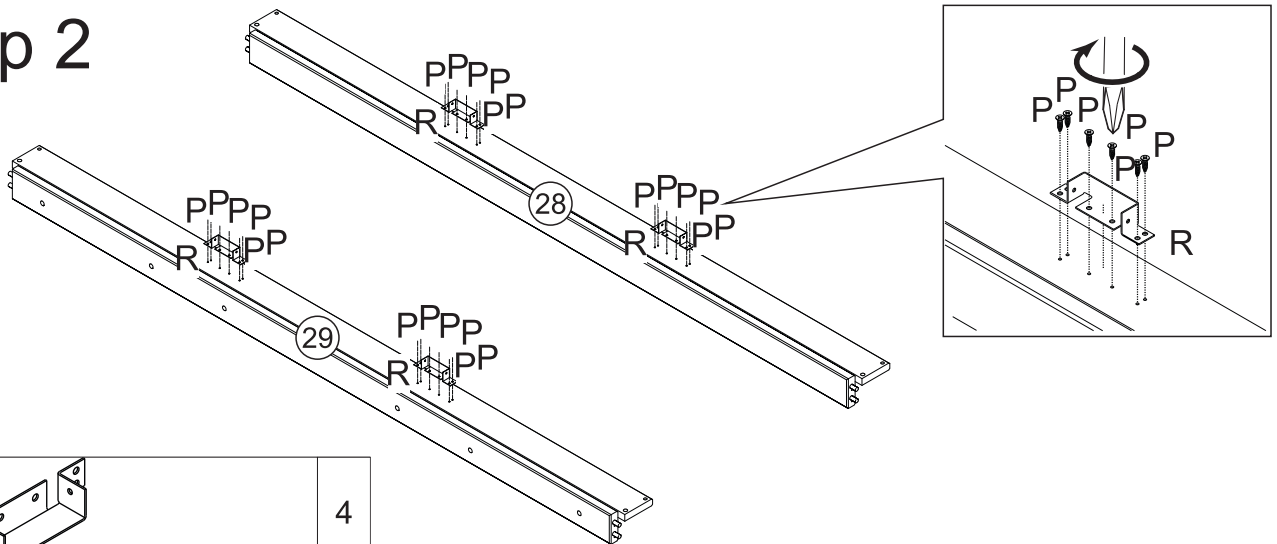

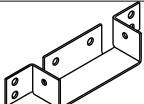
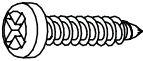

R		4
P		24
Ø4x16mm		

Attach center bar support (R) into parts (28,29) with screw (P) using a Phillip screwdriver (not included).

Step 3

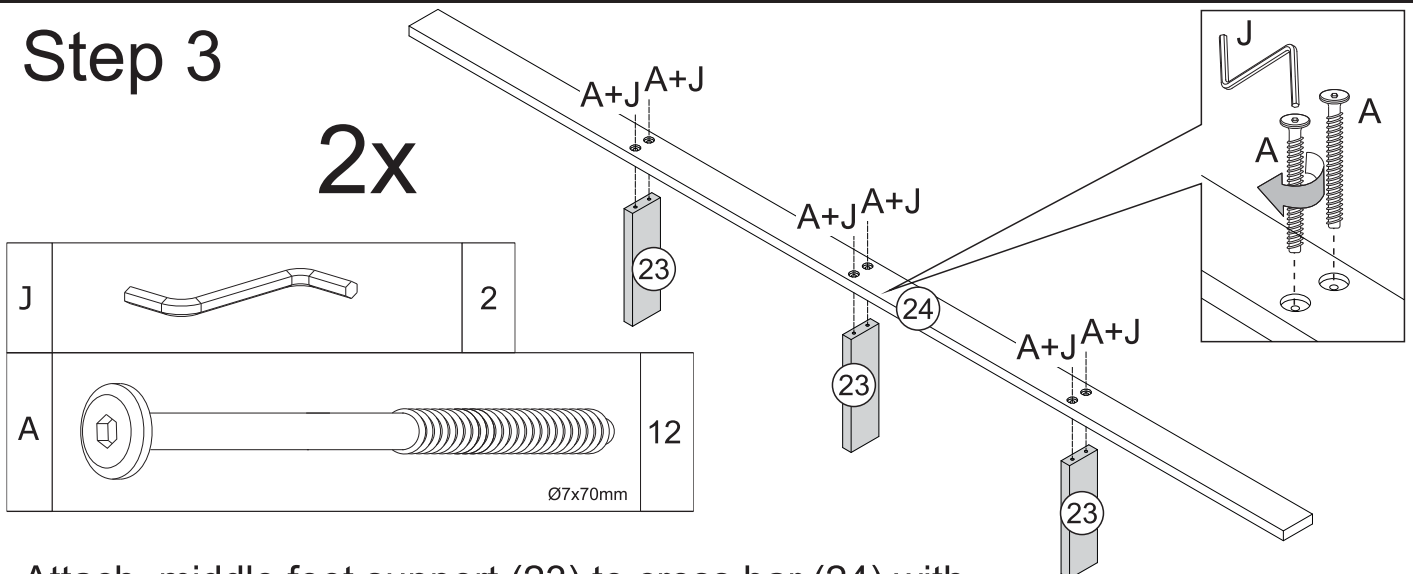
2x

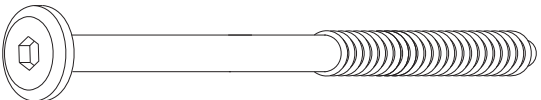

J		2
A		12
Ø7x70mm		

Attach middle foot support (23) to cross bar (24) with screw (A) using the hex key (J).

Step 4

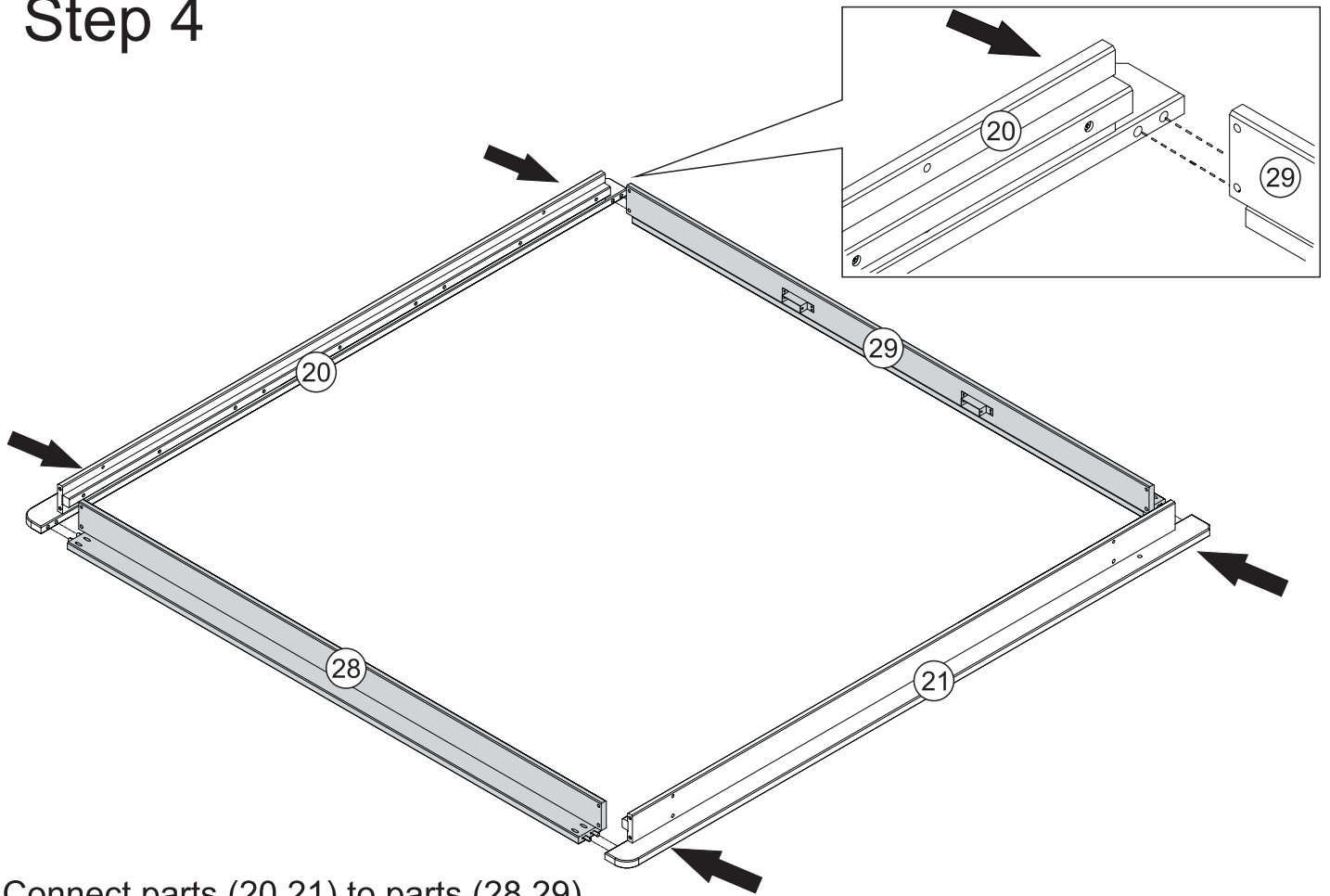

Connect parts (20,21) to parts (28,29).

Step 5

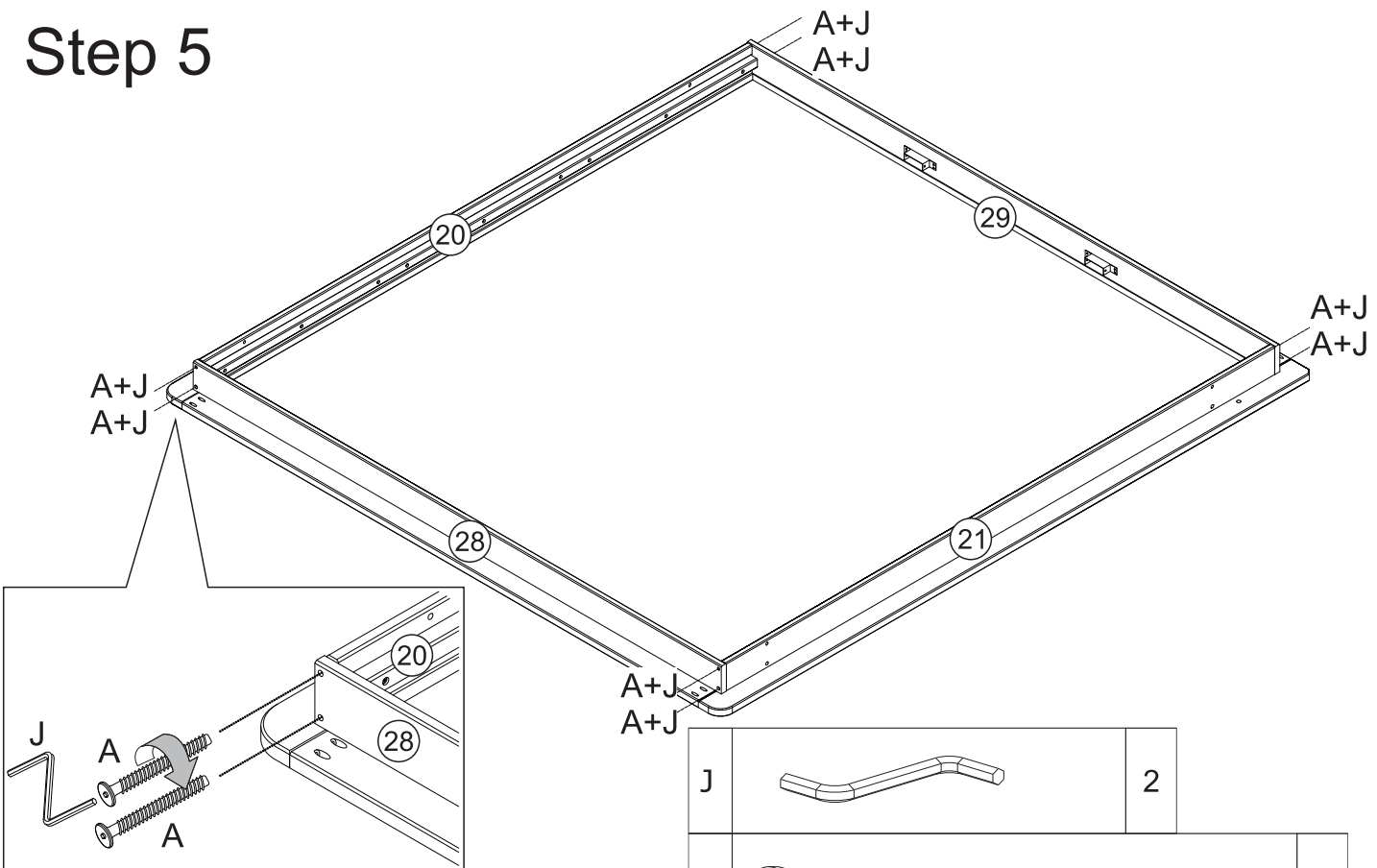

Secure parts (20,21) to parts (28,29) with screws (A), using the hex key (J).

Step 6

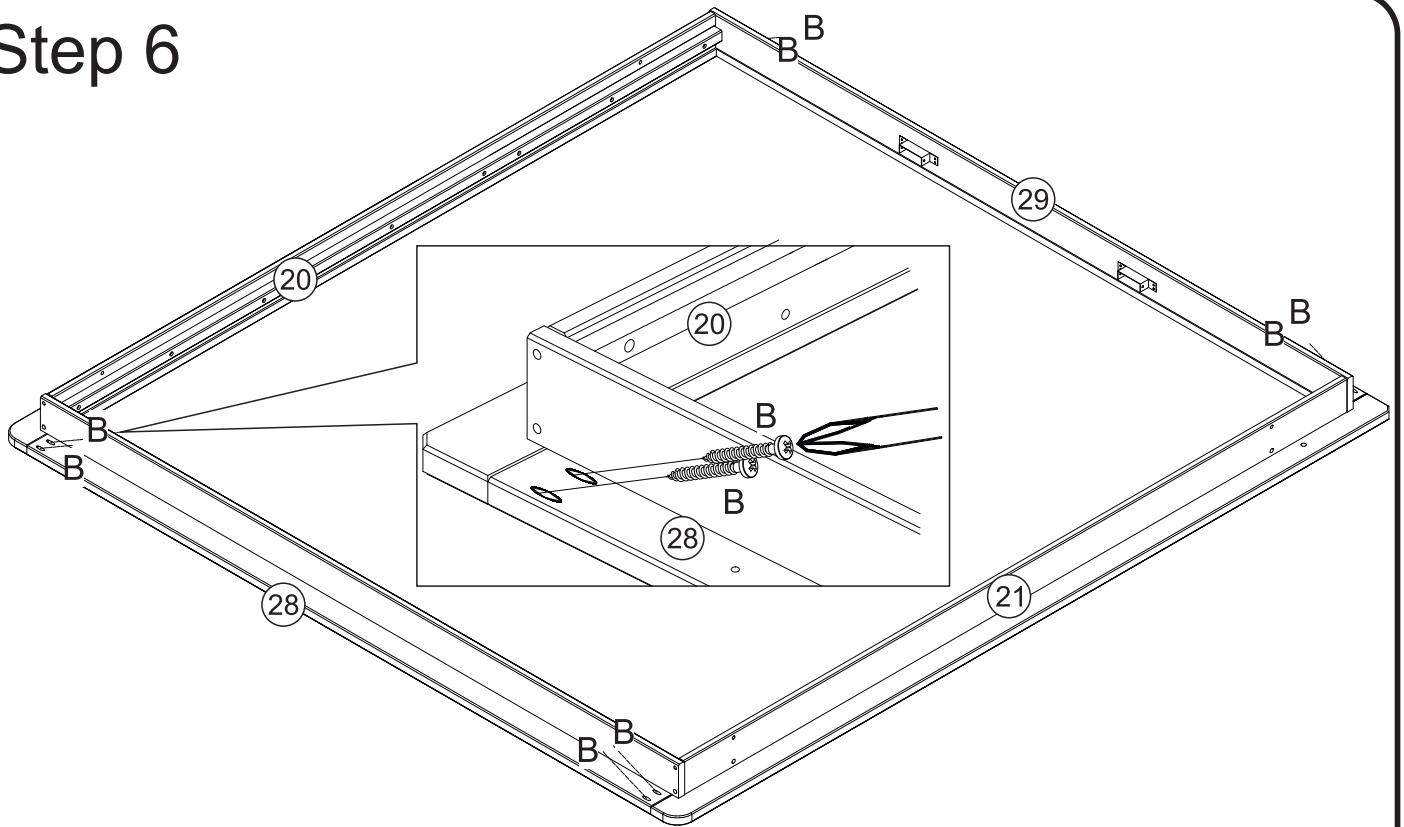

Connect parts (28,29) to parts (20,21) with screw B, using a Phillips screwdriver (not included).

B		8
		Ø3,5x30mm

Step 7

Attach feet (15) to frame parts (20,21) using screw (M) and Union Screw (N).

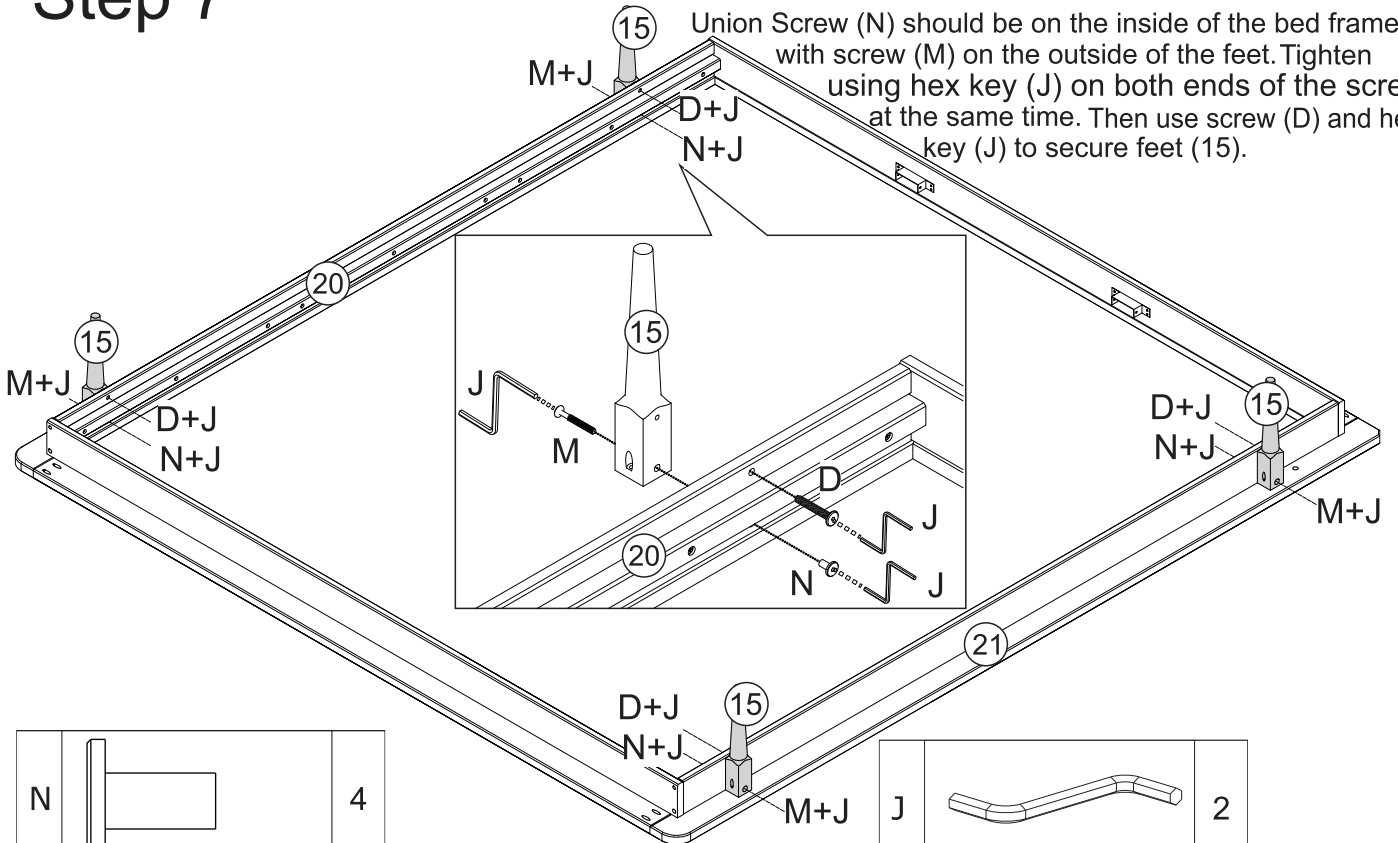

Union Screw (N) should be on the inside of the bed frame, with screw (M) on the outside of the feet. Tighten using hex key (J) on both ends of the screw at the same time. Then use screw (D) and hex key (J) to secure feet (15).

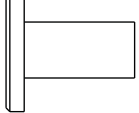
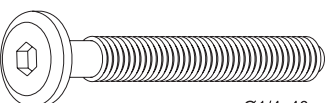
N		4
M		4
		Ø1/4x40mm

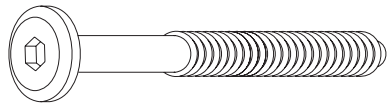
J		2
D		4
		Ø7x50mm

Step 8

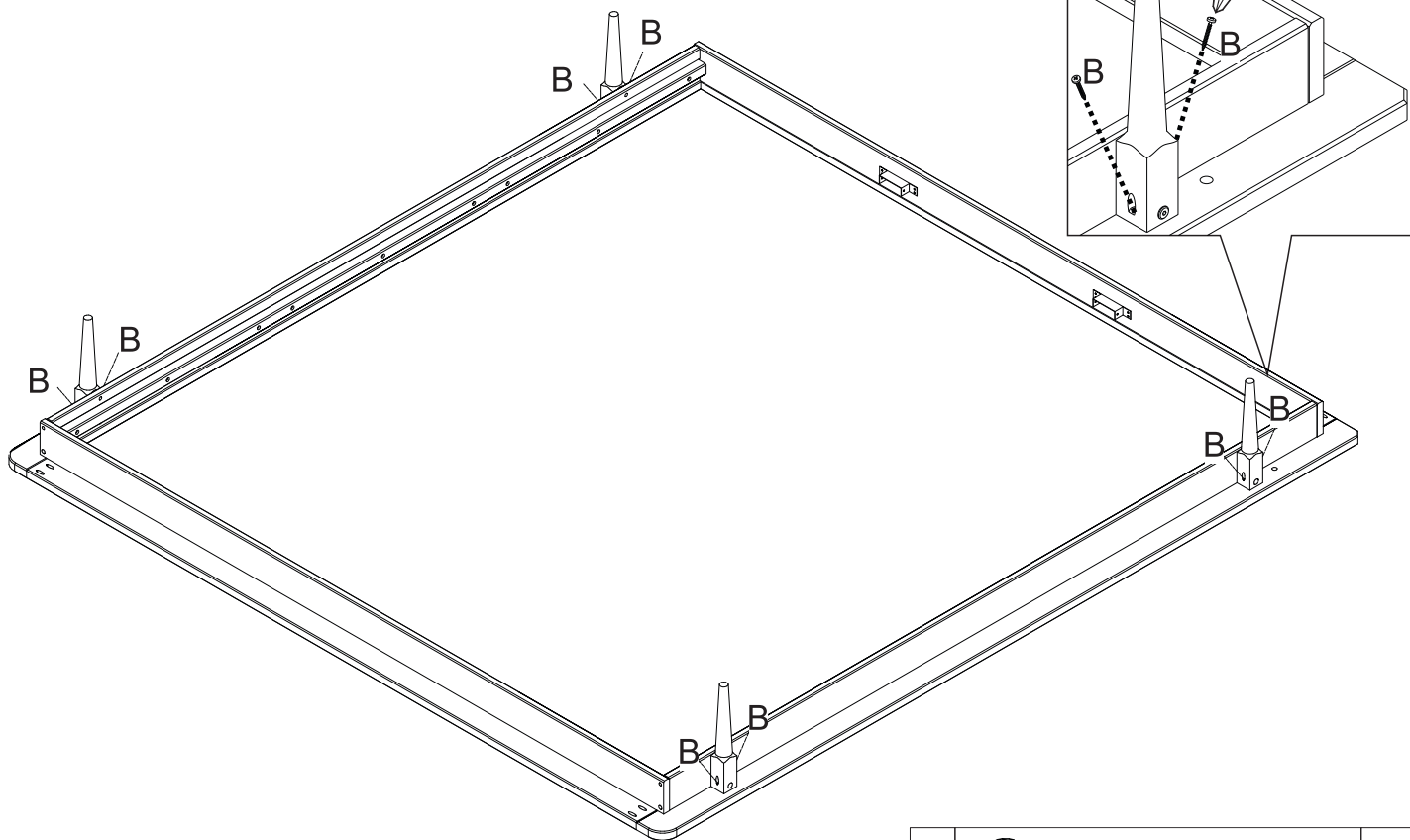

Secure feet to frame with screw (B) using a Phillips screwdriver (not included).

B		8
		Ø3,5x30mm

Step 9

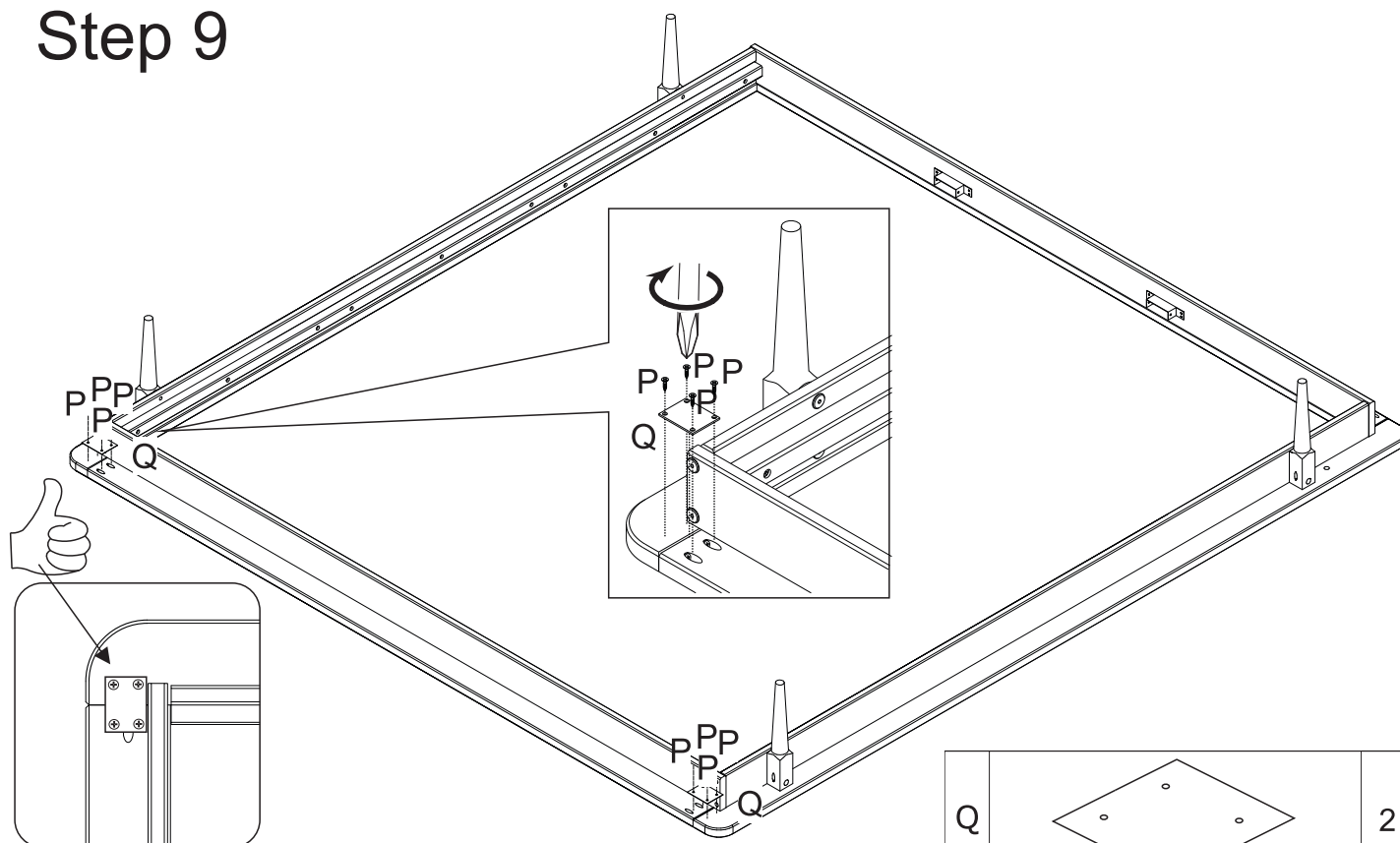

Attach the metal connector plate (Q) to the 2 corners of the bed with screw (P), using a Phillips screwdriver (not included).

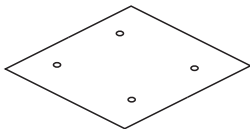
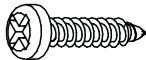
Q		2
P		8
		Ø4x16mm

Step 10

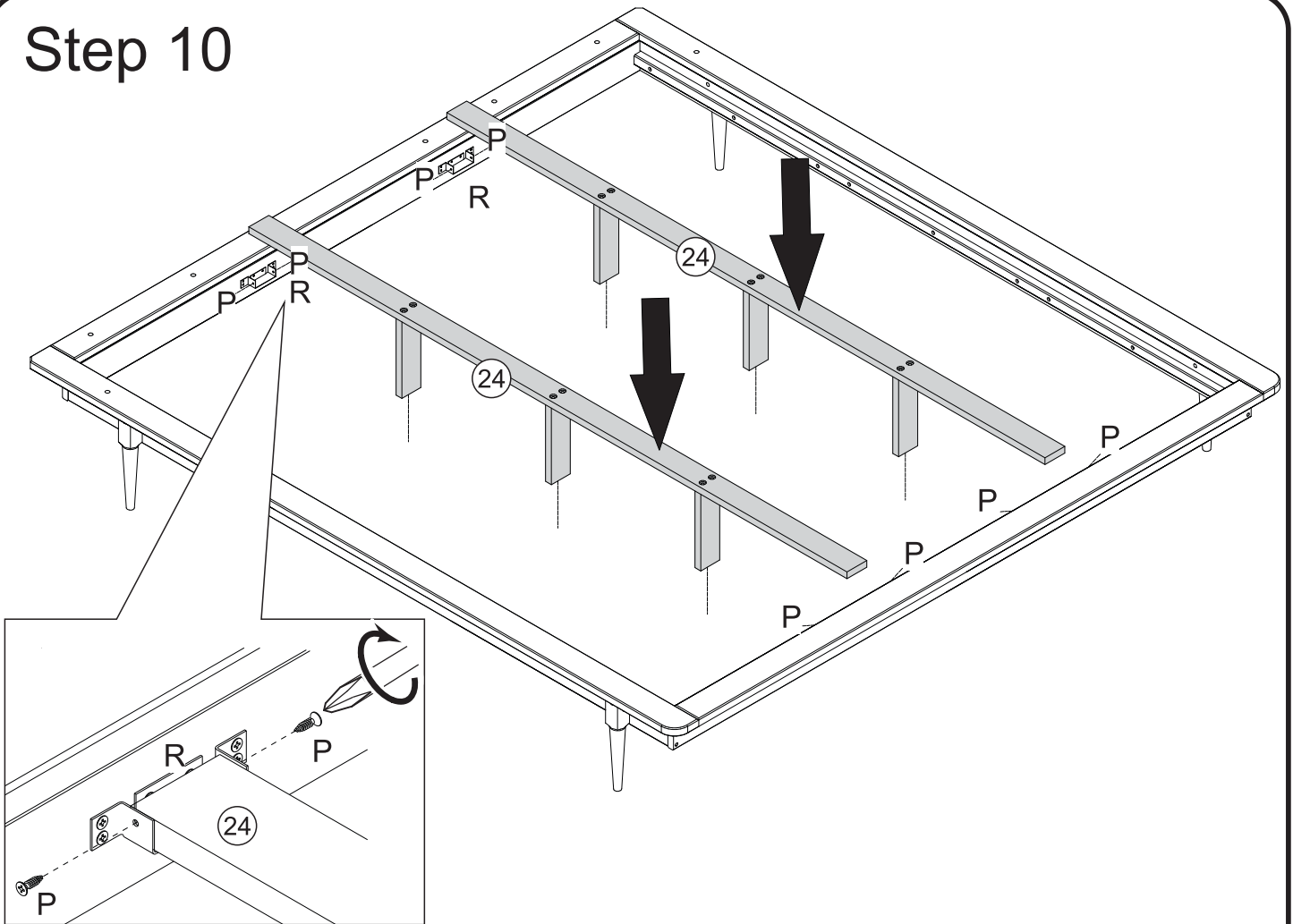

Secure part (24) to center bar support (R) with screw (P) using a Phillips screwdriver (not included).

P		Ø4x16mm	8
---	---	---------	---

Step 11

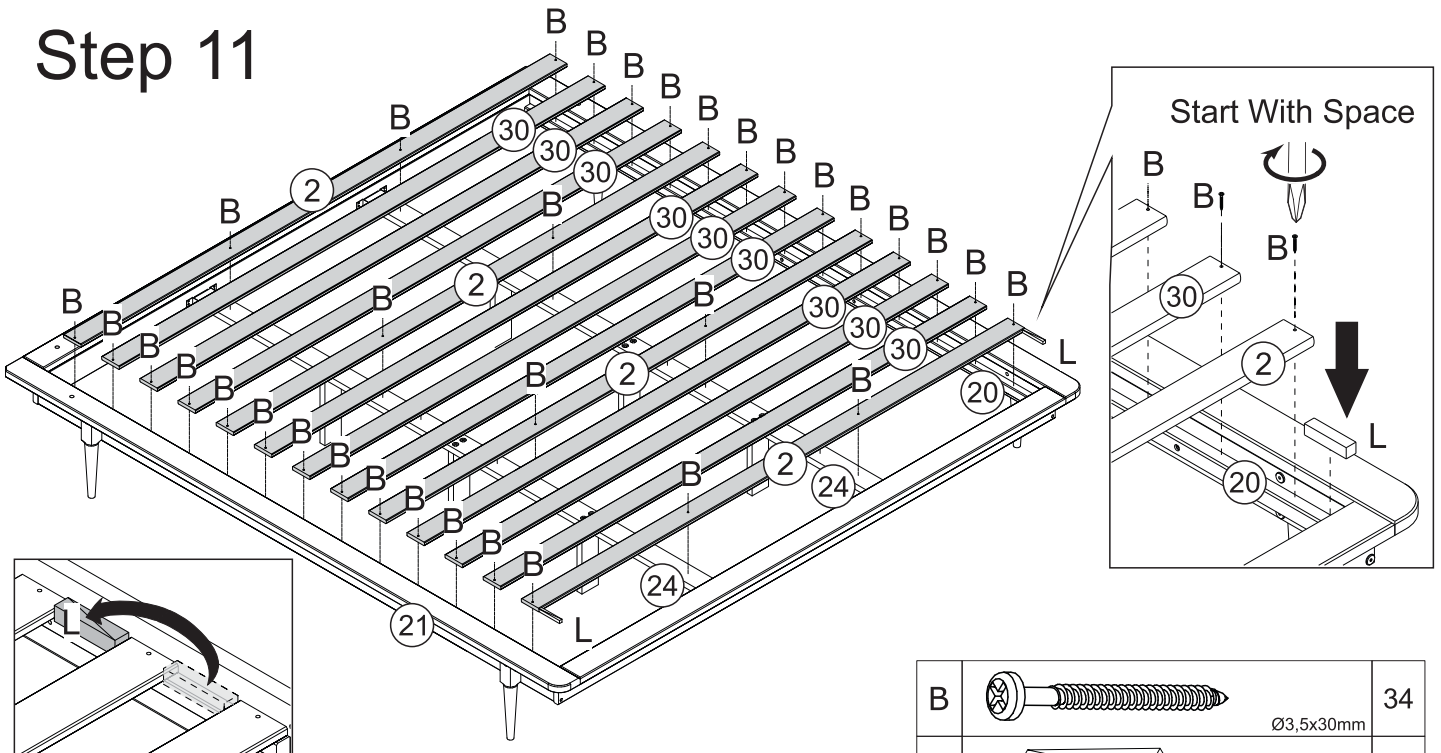

Align part 2 with 20, and use hardware L to space the next parts 2 and 30. Join pieces 2, 20, 21, 24, and 30 with screw B using a Phillips head screwdriver

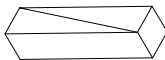
B		Ø3,5x30mm	34
L			2

Step 12

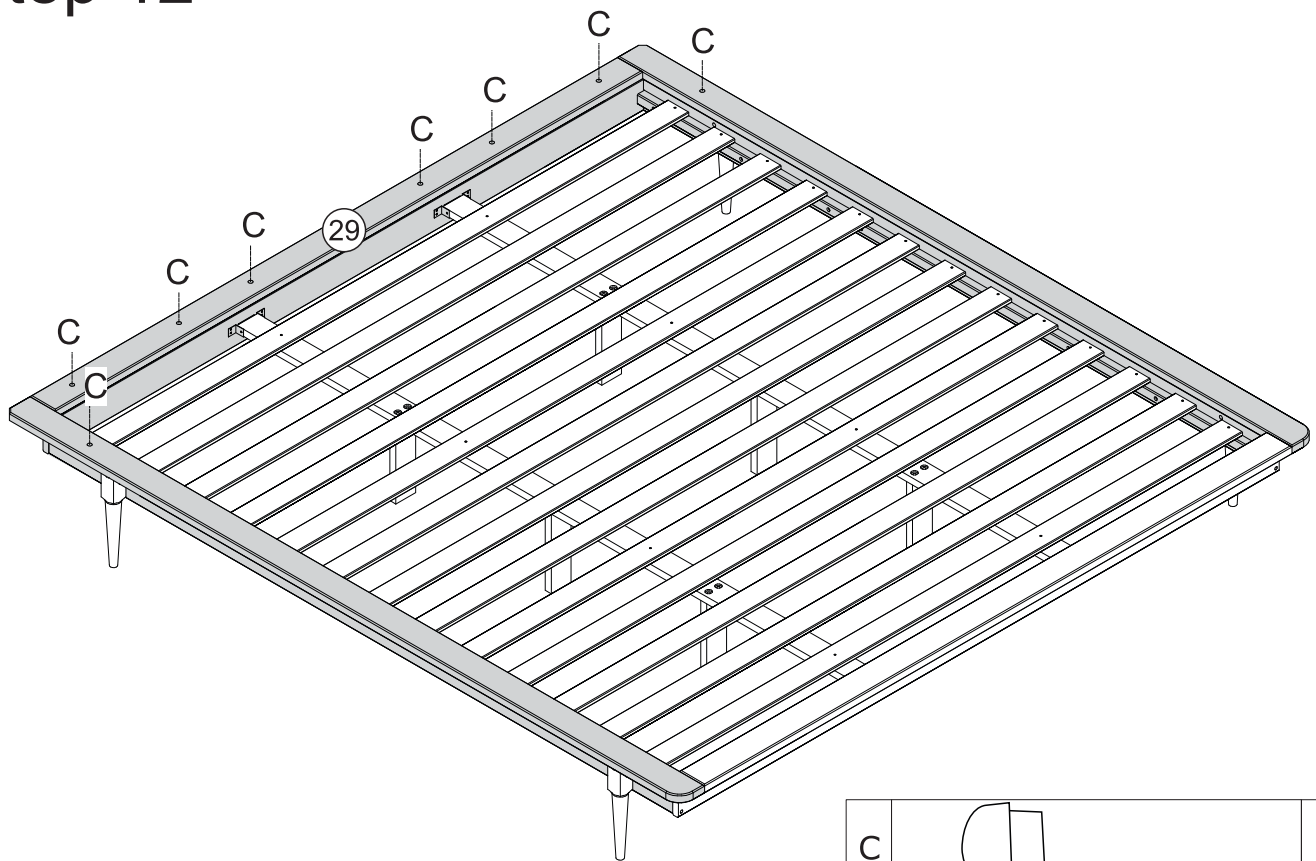

Fit the hole caps (C) to the exposed holes in the headboard and sides.

Step 13

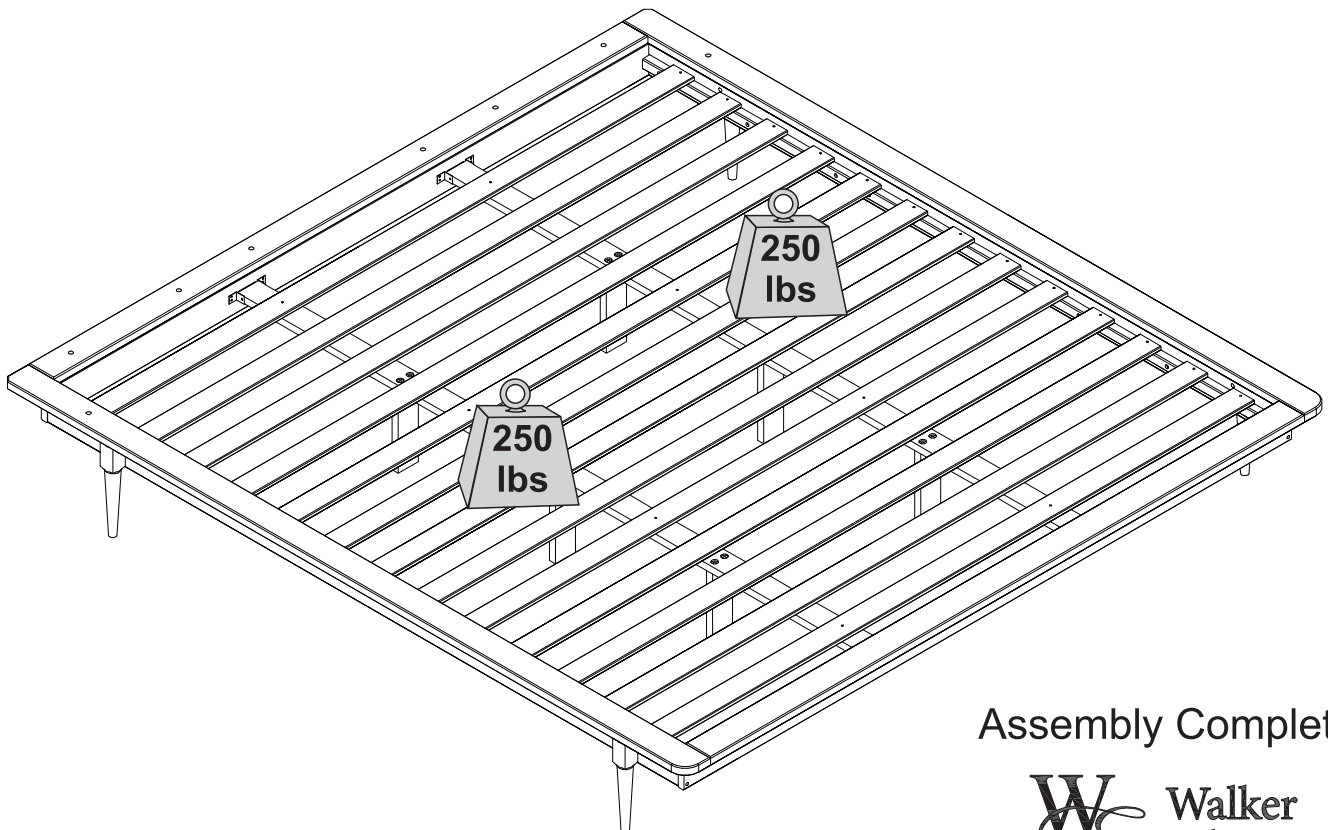

Assembly Complete!

 Walker
Edison®