

# 5.3-Gallon EZ STOR® Container with Non-Hinged Cover

## Multiple Uses

Dry Products

## Product Codes

Container: **EN53**

Description: 5.3-gallon rectangular can

Cover: **ESDN**

Description: Non-hinged dry seal, lightweight, tamper-evident, EZ open & close cover

## Features

- Built in hand grips
- Gauge: 70 mil.
- Nominal capacity: 5.3 USG / 20 L
- Stack performance: 280 lbs.\*
- Tare weights: Body: 1.61 lbs. / .73 kgs.
- Cover: .342 lbs. / .155 kgs.

Note: \*Ratings will be reduced with uneven load distribution.

## Specifications with Cover

- Dimensions: 11-15/16"L X 9-7/8"W X 14-11/16"H\*
- Maximum capacity: 5.6 USG / 21.2 L
- Tare weight: 1.952 lbs. / .885 kgs.

## Colors

- Standard: White, Black, Natural and Clear
- Custom: Available at manufacturer's discretion

## Decorating Options

- Four or six color offset printing
- NXT Graphics®
- Sleeve or pressure sensitive labeling

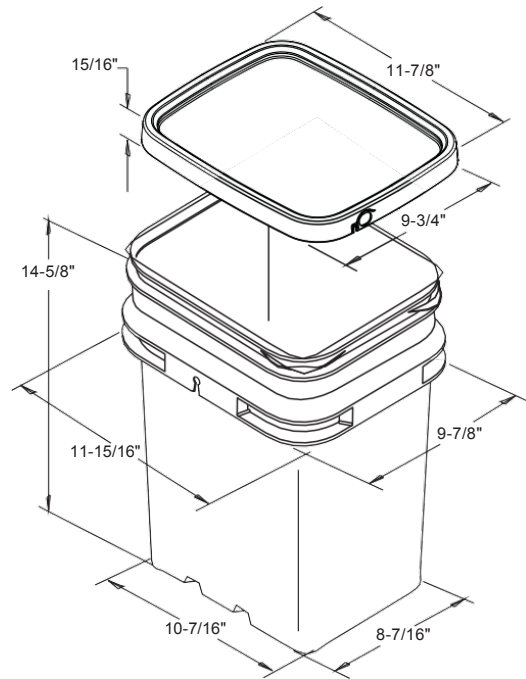

## Shipping Data

- Qty. per pallet:
- Gross Weight (lbs./kgs)\*:
- Den. (lbs./C.F./kgs./m3):
- Length (in./cm.):
- Width (in./cm.):
- Height (in./cm.):

## Bodies

- 160
- 257.6/116.8
- 4.5/72.8
- 48/121.9
- 40/101.6
- 51/129.5

## Covers

- 1,440 (30 boxes of 48)
- 492.5/223.2
- 5.3/85.5
- 48/121.9
- 40/101.6
- 83/210.8

## Filled Containers

- 48 (16 per layer / 3 layer high)
- Pallet height: 48.75"

Estimated truckload quantity of 6,336 bodies and covers\*\*

Notes: \*Weight does not include pallet / packaging

\*\*Truckload quantity based on 53' trailer

## Materials

- FDA approved materials
- Resin: Body: Polypropylene (PP)
- or Clarified Polypropylene
- Cover: Polypropylene (PP)

MSDS Sheets available upon request

## Optional Carrying Handle

DISTRIBUTED BY:	REF NO.:
	DWG30549
DESCRIPTION:	
HDPE EZ Stor Cover for 5.3 Gallon Pails	

## DISCLAIMER

THIS INFORMATION IS PROVIDED AS A GENERAL GUIDE, INCLUDING DIMENSIONS. IT IS THE CUSTOMER'S RESPONSIBILITIES TO SELECT THE PROPER CONTAINER FOR PRODUCT AND APPLICATION COMPATIBILITY.